

R&S® ZNB Vector Network Analyzer

Leading in speed,
dynamic range and
ease of operation



R&S®ZNB Vector Network Analyzer At a glance

More than 60 years of experience in the field of vector network analysis pay off: Rohde & Schwarz once again sets new benchmarks – with the R&S®ZNB vector network analyzers. The new family of network analyzers features high measurement speed, outstanding precision and exceptional ease of operation.

With frequency ranges of 9 kHz to 4.5 GHz, 9 kHz to 8.5 GHz, 100 kHz to 20 GHz and 10 MHz to 40 GHz, the new network analyzers are targeted at applications in the mobile radio and electronic goods industries as well as at applications for high-speed PCB design and aerospace and defense. The R&S®ZNB is the right choice when it comes to developing, producing and servicing RF components such as amplifiers, mixers, filters, connectors and cables.

The R&S®ZNB vector network analyzers feature a wide dynamic range of up to 140 dB (at 10 Hz IF bandwidth), low trace noise of less than 0.004 dB RMS (at 10 kHz IF bandwidth) and high output power of up to +13 dBm, which can be adjusted electronically in a range of more than 95 dB.

The new analyzers combine high measurement accuracy with exceptional speed – better than 10 μ s per point. They feature excellent temperature and long-term stability, which ensures reliable measurements over several days without having to recalibrate the units.

These short-depth, compact two-port and four-port analyzers leave plenty of space on the workbench for the measurement application. They feature low operating noise thanks to low power consumption and a sophisticated cooling concept. The low power consumption also reduces operating costs and protects the environment.

Key facts

- Frequency range from 9 kHz to 40 GHz
- Wide dynamic range of up to 140 dB
- Short sweep times of 4 ms for 401 points
- High temperature stability of typ. 0.01 dB/°C
- Wide power sweep range of 98 dB
- Wide range of IF bandwidths from 1 Hz to 10 MHz
- Manual and automatic calibration
- Large, high-resolution 12.1" screen
- Touchscreen user interface
- Two or four test ports
- Four-port model with two independent generators

R&S®ZNB40.

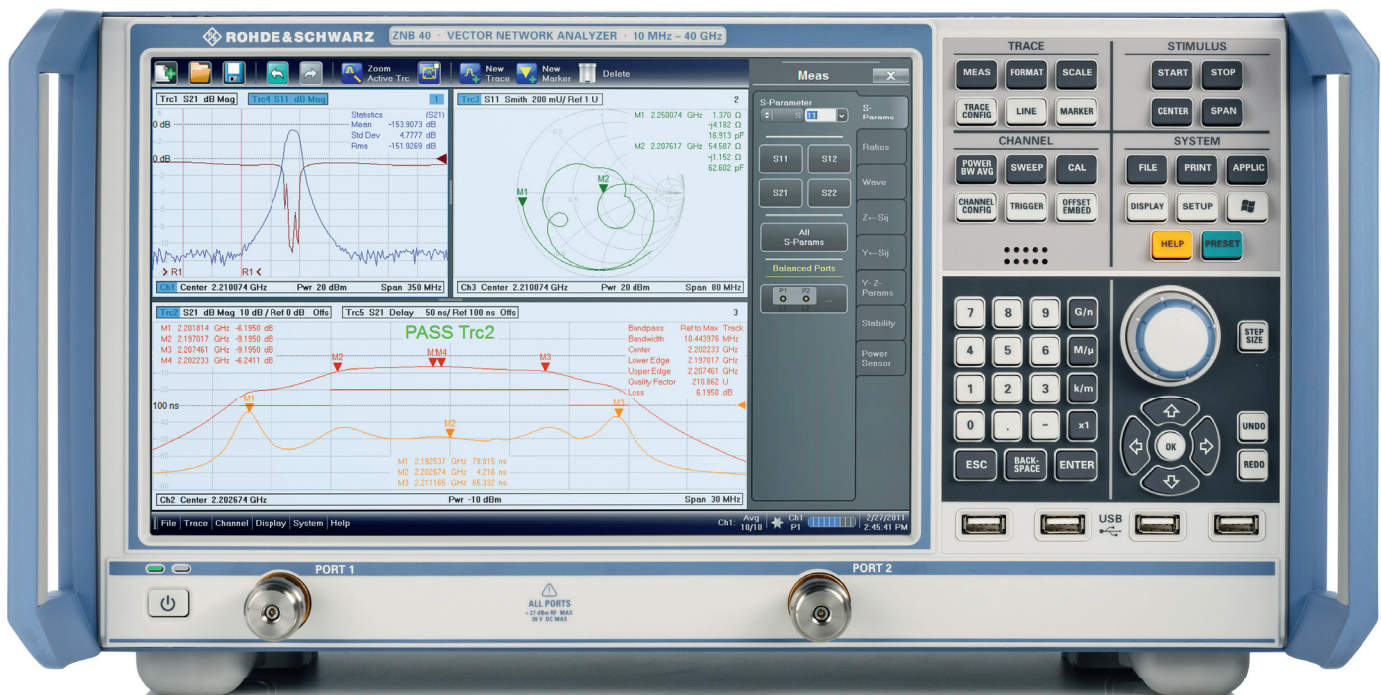

R&S®ZNB

Vector Network Analyzer

Benefits and key features

Designed to meet the highest standards

- ▮ Wide dynamic range from 9 kHz for fast measurements on high-blocking DUTs
- ▮ Excellent raw data for high basic accuracy
- ▮ High temperature stability for long calibration intervals
- ▮ Fast synthesizers for high measurement speed

▷ [page 4](#)

Convenient characterization of active and passive RF components

- ▮ Fast embedding/de-embedding for impedance matching using virtual networks
- ▮ Mixed-mode S-parameters for balanced DUT characterization
- ▮ Extensive analysis functions for convenient trace analysis
- ▮ Amplifier measurements with wide power sweep range and receiver step attenuators
- ▮ Time domain analysis for distance-to-fault (DTF) measurements and filter adjustment
- ▮ Frequency conversion measurements on mixers and amplifiers – fast and simple with two independent internal generators

▷ [page 6](#)

Network analysis made easy

- ▮ Flat and clear menu structures for efficient operation
- ▮ Optimal display configuration for each measurement task

▷ [page 8](#)

Simple calibration – manual or automatic

- ▮ The right calibration method for every test application
- ▮ TSM (Through, Short, Match) – full calibration in only five steps
- ▮ Simple and error-free – automatic calibration in 30 seconds

▷ [page 10](#)

Measurements with up to 32 ports

- ▮ More ports by use of switch matrices
- ▮ Easy configuration at the push of a button
- ▮ Automatic calibration units for accurate measurements

▷ [page 11](#)

High throughput in production

- ▮ Short measurement times
- ▮ High measurement speed due to wide dynamic range and optimized IF bandwidths
- ▮ Segmented sweep for high speed and accuracy
- ▮ Fast switching between instrument setups

▷ [page 12](#)

A worthwhile investment

- ▮ Ready for the future
- ▮ Upgrading test systems without rewriting system software
- ▮ An analyzer that speaks the user's language

▷ [page 13](#)

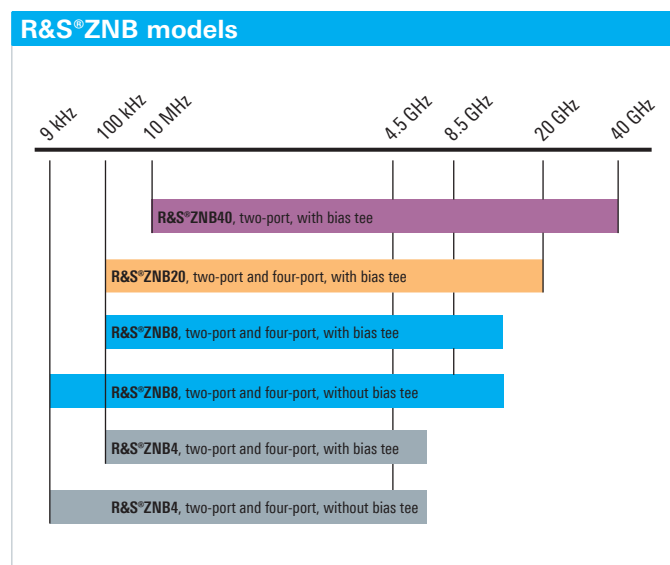

Designed to meet the highest standards

The analyzers of the R&S®ZNB family combine wide dynamic range, excellent raw data, high temperature stability and fast synthesizers to yield performance previously found only in high-end network analyzers. This makes the instruments ideally suited for applications in the development and large-scale production of sophisticated RF components.

Wide dynamic range from 9 kHz for fast measurements on high-blocking DUTs

The R&S®ZNB receivers combine high power-handling capacity with high sensitivity and low trace noise. The R&S®ZNB provides typically 140 dB dynamic range (at 10 Hz IF bandwidth), 10 dB better than that of other, comparable products on the market, which will mainly speed up manual adjustments of high-blocking filters.

Users will benefit from the R&S®ZNB's wide dynamic range not only in the mobile radio frequency bands, but right from the 9 kHz start frequency.

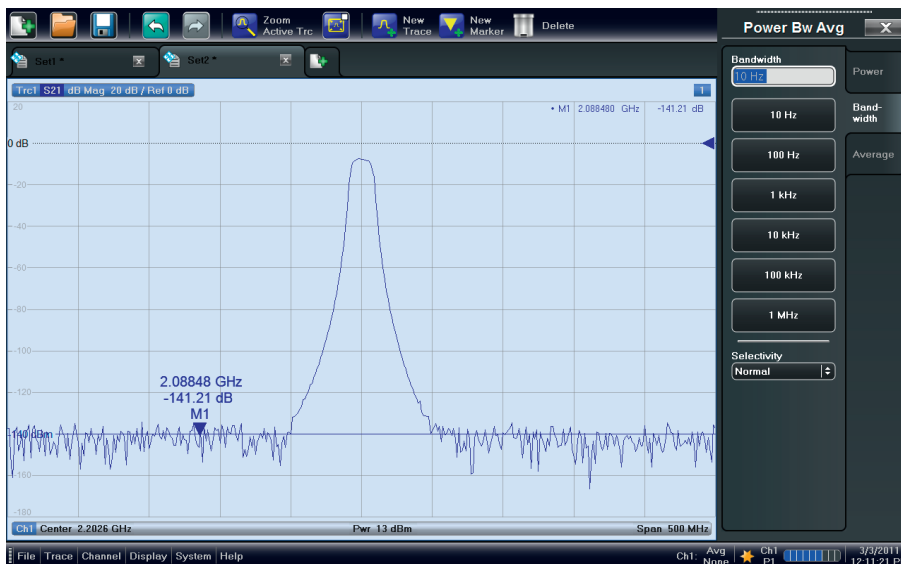

R&S®ZNB dynamic range (at 10 Hz IF bandwidth).

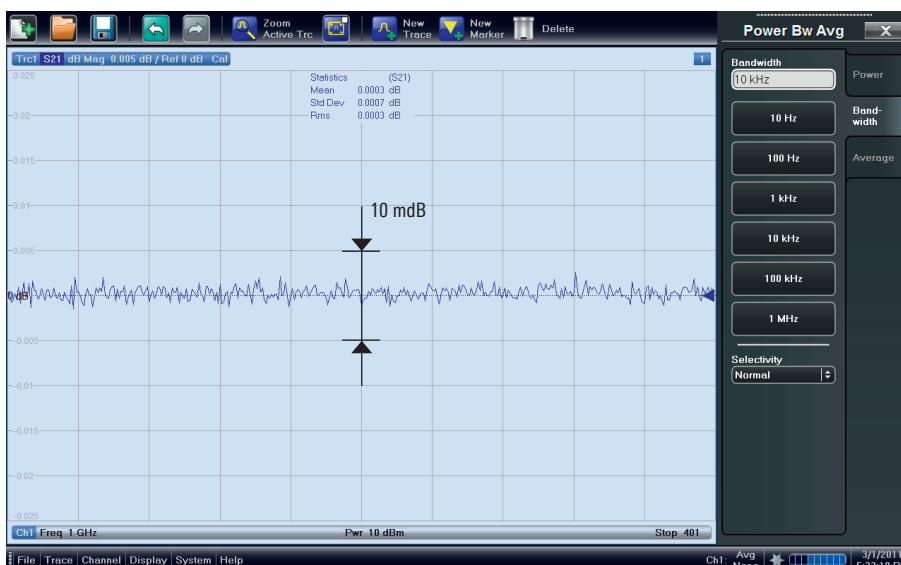

R&S®ZNB trace noise (at 10 kHz IF bandwidth).

Measurement speed, R&S®ZNB versus competitor products

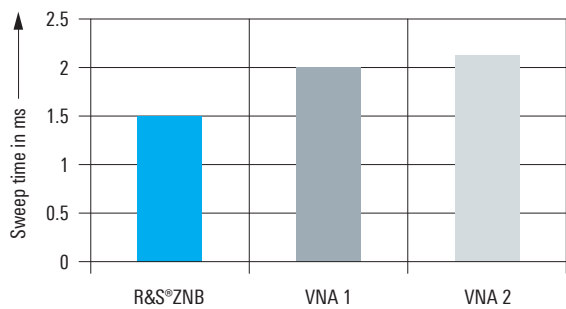

51 points, normalized

Block diagram of the R&S®ZNB four-port model with two internal generators

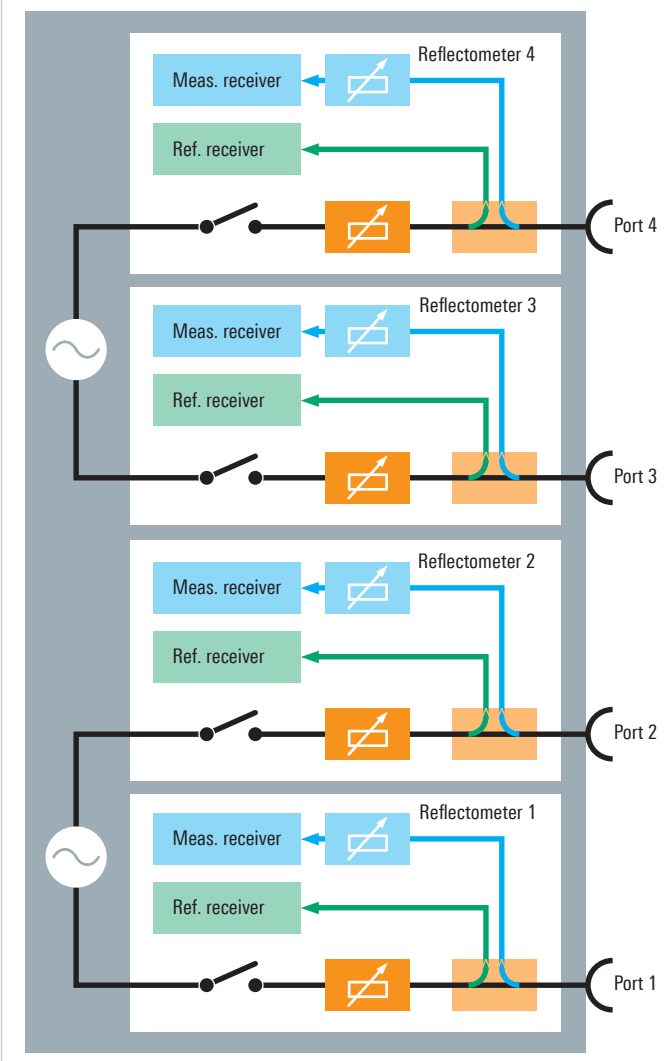

Excellent raw data for high basic accuracy

The R&S®ZNB offers directivity of more than 30 dB and a test port match of up to 25 dB even without calibration. Long-term and temperature stability are improved, and accuracy is increased even further after calibration. Even with partial calibration, for example transmission normalization with a through standard, the R&S®ZNB provides accuracy previously achieved only with complex two-port calibration – at a speed twice as high as with full two-port calibration.

High temperature stability for long calibration intervals

The R&S®ZNB’s test set and receivers feature excellent temperature and long-term stability. The analyzer measures S-parameters with very low magnitude and phase drift of typically less than 0.01 dB/°C and 0.15°/C. A calibrated R&S®ZNB allows precise measurements over several days without recalibration.

Fast synthesizers for high measurement speed

The R&S®ZNB has fast synthesizers with switching times of below 10 μs. This yields high sweep rates and allows the analyzer to perform measurements faster than competitor products.

Block diagram of the R&S®ZNB two-port model

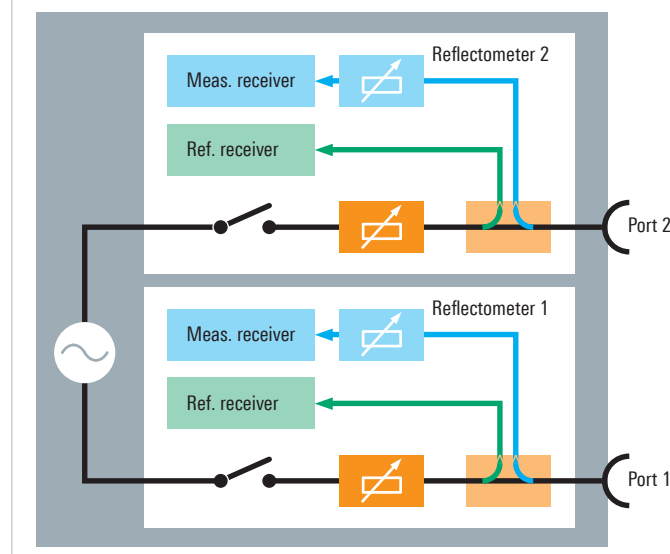

Convenient characterization of active and passive RF components

Fast embedding/de-embedding for impedance matching using virtual networks

Coaxial and balanced components, such as SAW filters used in mobile phone frontends, are specified together with the networks that match them to the impedance of the surrounding circuit. The R&S®ZNB can embed the DUT into virtual matching networks to provide realistic conditions by simulating the DUT installed in its operational environment. The R&S®ZNB offers a choice of predefined matching network topologies. The values of the individual network elements can be edited. If such values are edited, the R&S®ZNB immediately recalculates the network and embeds the DUT in the new network in realtime. In addition to predefined topologies, *.s2p and *.s4p files can be read into the R&S®ZNB and used for embedding/de-embedding.

Mixed-mode S-parameters for balanced DUT characterization

To characterize a DUT with two balanced ports, the R&S®ZNB treats the DUT as an unbalanced four-port device. It calculates the 16 single-ended S-parameters and converts them to mixed-mode S-parameters. This additional computational effort does not compromise measurement speed. A wizard guides the user through the individual steps of the measurement – fast and straightforward.

Extensive analysis functions for convenient trace analysis

A wide variety of analysis functions help the user evaluate important parameters at a glance:

- Ten markers per trace
- Automatic bandwidth measurements
- Limit line and ripple check with pass/fail indication
- Statistical trace analysis including maximum, minimum, RMS and peak-to-peak detection as well as compression point measurement
- Equation editor for complex, realtime trace mathematics

Amplifier measurements with wide power sweep range and receiver step attenuators

The R&S®ZNB's wide, electronically adjustable power sweep range from -85 dBm to +13 dBm enables fast analysis of the linear and nonlinear characteristics of small and large-signal amplifiers.

Electronic step attenuators in the receive paths increase the 0.1 dB compression point to +27 dBm. The wear-free attenuators feature delay-free switching, which enhances measurement speed and extends the R&S®ZNB's useful life in production.

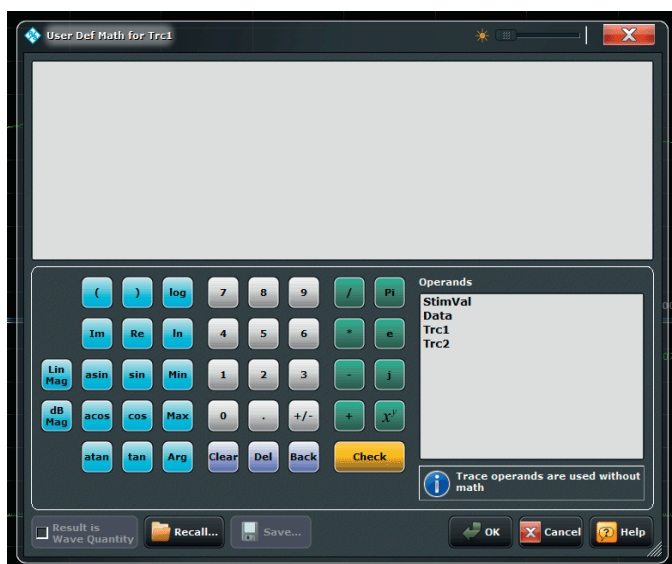
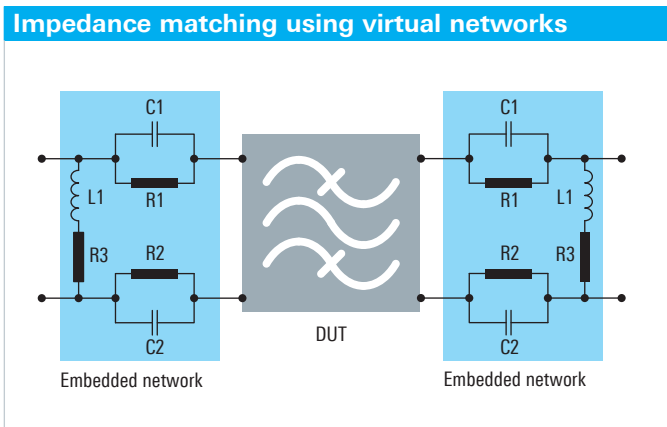

Equation editor for trace mathematics.

Additional features:

- ▮ Four DC inputs for measuring amplifier DC power consumption and efficiency
- ▮ Measurement of stability factors of balanced and unbalanced amplifiers
- ▮ Support of R&S®NRP-Zxx power sensors, providing high-precision power versus power and power versus frequency measurements

Time domain analysis for distance-to-fault (DTF) measurements and filter adjustment

The R&S®ZNB offers powerful time domain analysis to measure components such as cables or filters. With 100 000 points per trace, the R&S®ZNB measures even electrically long DUTs such as long cables without any problems. The R&S®ZNB's gating function makes it easy to locate cable faults and analyze them in detail.

Using prediction, the R&S®ZNB's frequency range can be virtually extended by a factor of up to 10. This yields resolution substantially higher than would be expected from the upper frequency limit of 4.5 GHz or 8.5 GHz. For many applications, this eliminates the need for a higher-frequency – and more expensive – network analyzer.

Frequency conversion measurements on mixers and amplifiers – fast and simple with two independent internal generators

When equipped with the frequency conversion and intermodulation measurements options, the R&S®ZNB measures harmonics and intermodulation products on amplifiers as well as conversion loss, matching and isolation on mixers, both versus frequency and power. A special calibration technique combines a power calibration with a system error correction to precisely characterize the magnitude of the conversion loss of mixers. Wizards guide the user step by step to the desired test setup and through calibration.

For complex measurements, such as on frontends with multiple mixer stages, the R&S®ZNB can control multiple external signal generators via LAN or IEC/IEEE bus.

Typical test setup for a mixer measurement



The R&S®ZNB four-port models can optionally be equipped with a second, independent internal generator, which can be used as a local oscillator in mixer measurements, for example, or to deliver the second tone for intermodulation measurements. This feature boosts measurement speed by a factor of up to 10 over setups using an external, IEC/IEEE bus controlled generator. Plus, it significantly simplifies the test setup.



Wizard for mixer measurements.

Network analysis made easy

The R&S®ZNB vector network analyzers turn into reality what many users desire: configuration, measurement and analysis that are truly intuitive.

Flat and clear menu structures for efficient operation

The R&S®ZNB groups together logically related analyzer control functions at a single operational level, doing away with submenus and multilevel, nested menu structures.

- The R&S®ZNB features a soft panel that immediately shows all control elements that may be needed for a measurement and effectively helps users perform measurement tasks
- Via the soft panel, users can access all instrument functions in a maximum of three operating steps
- Pop-up menus allow many test parameters to be edited right where they are displayed
- Wizards guide the user through the steps of an operating sequence, for example when calibrating the network analyzer, thereby reducing operator errors to a minimum

Clearly structured user interface



Optimal display configuration for each measurement task

The R&S®ZNB features a brilliant 12.1" WXGA color touchscreen. The user can set up the display as required by arranging diagrams, traces and channels in any desired combination. Traces can simply be dragged and dropped between diagrams, either with a finger or the mouse. The names of traces, channels and markers can be edited and replaced by user-specific names to make them easier to identify and to provide consistent result documentation.

With the R&S®ZNB, several instrument setups are available simultaneously. The user simply touches or clicks a tab to put the desired setup and diagrams in the foreground and start the associated measurements.

This convenient approach makes it possible to handle different measurement tasks simultaneously without overloading the display with diagrams that are not currently needed. The user can add further measurements for a given component without modifying the original measurement. This function allows the user to very quickly switch between setups, an essential prerequisite for high throughput in production.



Toolbar

Fast access to frequently used functions

Soft panel

Optionally on the right or left, for direct instrument control without submenus

Logically arranged hardkeys

Just a few keystrokes to desired configuration

Online help

Context-sensitive, including remote control commands

Undo/Redo

Cancels or restores the last one to six entries

Widely spaced test ports

Easy connection of DUT
Plenty of space for connecting test cables

Transparent dialog windows

Traces remain visible

USB connectors for auxiliary equipment

Connection of power sensor, automatic calibration unit, mouse/keyboard, memory stick, etc.

Simple calibration – manual or automatic

The right calibration method for every test application

The R&S®ZNB supports all common calibration methods for coaxial DUTs as well as calibration methods for measurements on DUTs in test fixtures and on printed boards. Graphical wizards guide the user step by step through the calibration.

- **TOSM** calibration (**T**hrough, **O**pen, **S**hort, **M**atch)
- **TRL/LRL** calibration (**T**hrough, **R**eflect, **L**ine/Line, **R**eflect, **L**ine) for printed-board-based test structures and on-wafer applications
- **TRM** calibration (**T**hrough, **R**eflect, **M**atch) for applications using test fixtures
- **UOSM** calibration (**U**nknown Through, **O**pen, **S**hort, **M**atch) for DUTs equipped with different types of input and output connectors and for calibration with an unknown through standard. Compared with the conventional adapter removal calibration method, this method reduces the number of calibration steps from 14 to 7. This saves time and reduces the risk of calibration errors

TSM (Through, Short, Match) – full calibration in only five steps

A network analyzer's accuracy after calibration essentially depends on the quality of the calibration standards used. The quality of the standards, in turn, depends mainly on how accurately the standards can be described by models. Describing the open standard using a model may be problematic; Rohde & Schwarz therefore created the new TSM calibration method for the R&S®ZNB. The new method requires only a through, a short and a match standard; an open standard is not needed. TSM provides accuracy equivalent to that of TOSM, and reduces the number of calibration steps from seven to five.

Simple and error-free – automatic calibration in 30 seconds

Rohde & Schwarz offers automatic calibration units with two and four ports. The units are immediately ready for operation and calibrate an R&S®ZNB in less than 30 seconds, covering 201 points. Users can connect adapters to the calibration unit to match different connector types used on the DUT. They can re-characterize the calibration unit, together with the adapters, and store the resulting data to the unit's internal memory.



R&S®ZNB calibration wizard.

Typical effective system data of the R&S®ZNB4/ R&S®ZNB8

	9 kHz to 100 kHz	100 kHz to 4.5 GHz	4.5 GHz to 8.5 GHz
Directivity	46	45	40
Source match	41	40	36
Load match	44	45	40
Reflection tracking	0.02	0.02	0.05
Transmission tracking	0.028	0.018	0.09

Measurements with up to 32 ports

More ports by use of switch matrices

Advanced components, such as frontend modules in smartphones and tablet PCs, support more and more frequency bands and additional functions such as WLAN, Bluetooth® and GPS. Furthermore, the use of differential components leads to an increasing number of RF ports. The R&S®ZNB in combination with various switch matrices provides a comprehensive solution for complex measurements on modules with up to 32 ports. Most of the Rohde&Schwarz switch matrices are full crossbar, allowing unrestricted measurements between all DUT ports.

Easy configuration at the push of a button

The R&S®ZNB controls the switch matrices via LAN and USB. A four-port model, for example, enables users to combine two switch matrices with two input ports and 16 output ports each for characterizing DUTs with up to 32 ports. Once connected, the switch matrix type is automatically identified and configured making the multiplexed ports as easy to use as the base unit. S-parameters, wave quantities and wave quantity ratios are directly selected and displayed in the R&S®ZNB user interface, eliminating the need for additional software or macros to configure and control the setup or measurement.

Automatic calibration units for accurate measurements

Automatic calibration units minimize the number of extensive connections during multipoint calibration. Rohde&Schwarz offers various calibration units with up to eight ports and a calibration wizard to ease the calibration of large numbers of ports.

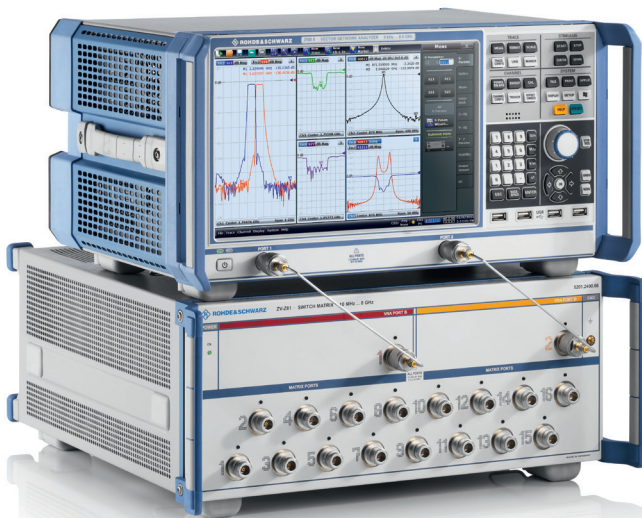

R&S®ZNB with switch matrix.



Automatic assignment of test ports in the R&S®ZNB.



R&S®ZV-Z58 eight-port calibration unit.



R&S®ZV-Z51 four-port calibration unit.

High throughput in production

Short measurement times

The R&S®ZNB features short measurement times, a result of fast synthesizer settling times, short sampling times due to large IF bandwidths, high-speed data processing up to the display, and fast LAN or IEC/IEEE bus data transfer to the controller.

The analyzer's large IF bandwidths enable fast sampling times of less than 1 μ s per point. The large IF bandwidths, combined with the short synthesizer settling times, yield a total measurement time of no more than 4 ms for a frequency sweep covering 401 points.

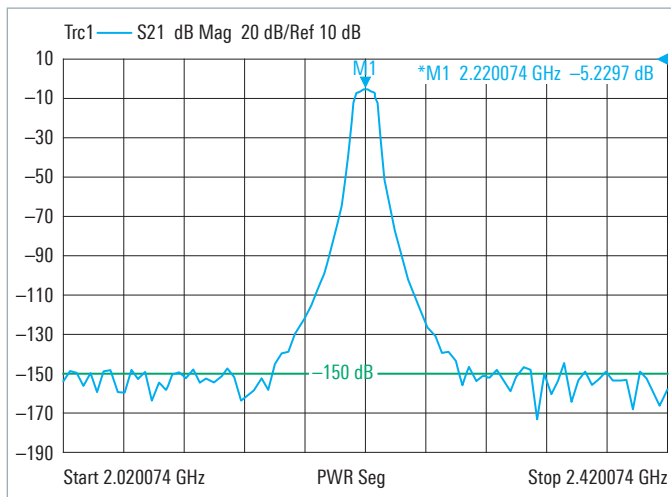

Filter measurement with segmented sweep.



Dialog for configuring a segmented sweep.

High measurement speed due to wide dynamic range and optimized IF bandwidths

Measurement speed for tests on high-blocking DUTs, such as on base station duplex filters, is determined by the required dynamic range and the corresponding IF bandwidth. The R&S®ZNB features a dynamic range more than 10 dB higher than that of comparable products on the market. This means that, at an IF bandwidth higher by a factor of 10, the R&S®ZNB measures ten times faster than comparable products at the same dynamic range. The R&S®ZNB offers IF bandwidths from 1 Hz to 10 MHz, settable in steps of 1, 1.5, 2, 3, 5, 7 and 10, for optimized speed and dynamic range.

The R&S®ZNB offers up to 140 dB dynamic range for a 10 Hz IF bandwidth. For a sweep with 110 dB dynamic range covering 201 points, the R&S®ZNB requires less than 30 ms, a value that is attractive for base station filter manufacturers.

Segmented sweep for high speed and accuracy

When testing high-blocking DUTs such as repeater duplex filters, high IF bandwidths are required in the passband to provide short measurement times. In the stopband, on the other hand, such tests require high output powers and narrow IF bandwidths to provide the required dynamic range.

The R&S®ZNB's segmented sweep function divides the frequency axis into segments. Sweep parameters such as output power, IF bandwidth and number of points can be defined separately for each segment to optimally match the DUT characteristics. This increases measurement speed without any loss in accuracy.

Fast switching between instrument setups

To carry out complex measurements with different instrument setups, R&S®ZNB users do not need to load the setups from the hard disk each time. Once called, the setups for the required measurements, including calculated data such as calibration values, remain available in RAM. This reduces switching time, especially for measurements involving a large number of points. Switching between setups in remote operation is virtually instantaneous. Manually, all the user has to do is touch the screen to activate the setup needed for a desired DUT or measurement.

A worthwhile investment

Ready for the future

Industrial network analyzers have a useful life of ten years or more, depending on the application. Measurement tasks often change during this time, and there is an obvious need to increase measurement speed.

The R&S®ZNB has a modular design, i.e. subassemblies such as DC inputs, GPIB interface, power supply, controller and hard disk are inserted into slots on the rear. All test applications can be activated with a key code.

The R&S®ZNB can be quickly upgraded for new measurement tasks. Keeping the R&S®ZNB up to date, such as by adding a more powerful, next-generation controller or new functionality, involves only minimum downtime and service cost.

Upgrading test systems without rewriting system software

Network analyzers are the core of many test systems, for example in RF component production. Using latest generation Rohde&Schwarz network analyzers, system performance can be significantly enhanced.

The R&S®ZNB supports the remote control command sets of practically all other Rohde&Schwarz network analyzers as well as those of other manufacturers' instruments. Replacing an obsolete analyzer with an R&S®ZNB therefore poses no problems. In most cases it is sufficient to verify the R&S®ZNB's response during a measurement sequence; there is no need for costly modifications in the system software.

An analyzer that speaks the user's language

Many tasks are easiest solved in one's native language; the R&S®ZNB therefore comes with a multilingual user interface. Currently available languages include English, French, Spanish, Russian, Chinese and Japanese.

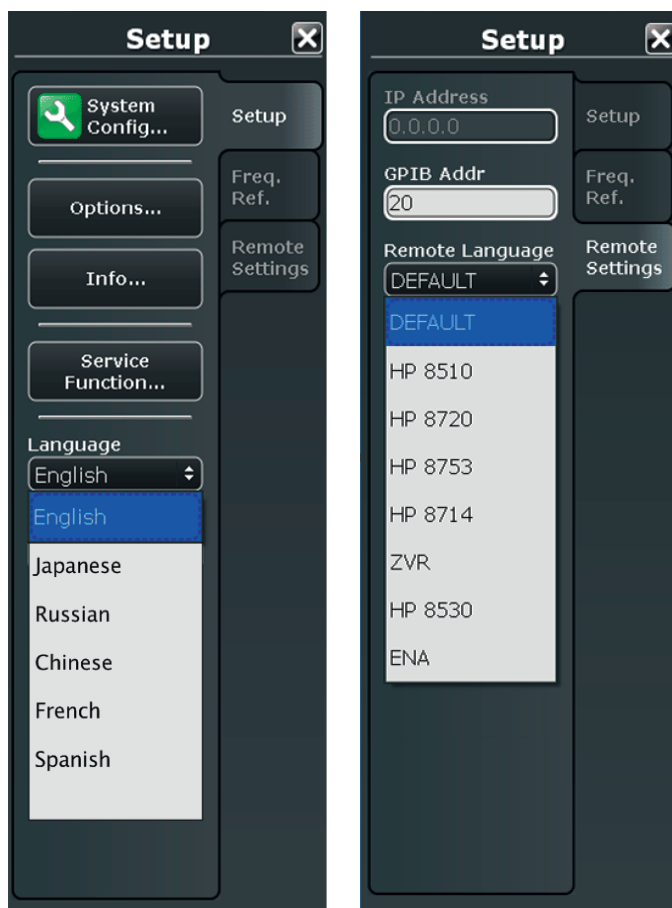

Soft panel menus for selecting language (left) and remote control command set (right).

Ordering information

Designation	Type	Frequency range	Order No.
Base units			
Vector Network Analyzer, Two Ports, 4.5 GHz, N	R&S®ZNB4	9 kHz to 4.5 GHz	1311.6010.22
Vector Network Analyzer, Four Ports, 4.5 GHz, N	R&S®ZNB4	9 kHz to 4.5 GHz	1311.6010.24
Vector Network Analyzer, Two Ports, 8.5 GHz, N	R&S®ZNB8	9 kHz to 8.5 GHz	1311.6010.42
Vector Network Analyzer, Four Ports, 8.5 GHz, N	R&S®ZNB8	9 kHz to 8.5 GHz	1311.6010.44
Vector Network Analyzer, Two Ports, 20 GHz, 3.5 mm	R&S®ZNB20	100 kHz to 20 GHz	1311.6010.62
Vector Network Analyzer, Four Ports, 20 GHz, 3.5 mm	R&S®ZNB20	100 kHz to 20 GHz	1311.6010.64
Vector Network Analyzer, Two Ports, 40 GHz, 2.92 mm	R&S®ZNB40	10 MHz to 40 GHz	1311.6010.72
Options			
Bias Tees for Two-Port R&S®ZNB4/R&S®ZNB8	R&S®ZNB-B1	100 kHz to 4.5/8.5 GHz	1316.1700.02
Bias Tees for Four-Port R&S®ZNB4/R&S®ZNB8	R&S®ZNB-B1	100 kHz to 4.5/8.5 GHz	1316.1700.04
Receiver Step Attenuator, Port 1, for R&S®ZNB4	R&S®ZNB4-B31	9 kHz to 4.5 GHz	1316.0185.02
Receiver Step Attenuator, Port 2, for R&S®ZNB4	R&S®ZNB4-B32	9 kHz to 4.5 GHz	1316.0179.02
Receiver Step Attenuator, Port 3, for R&S®ZNB4	R&S®ZNB4-B33	9 kHz to 4.5 GHz	1316.0262.02
Receiver Step Attenuator, Port 4, for R&S®ZNB4	R&S®ZNB4-B34	9 kHz to 4.5 GHz	1316.0433.02
Extended Power Range for Two-Port R&S®ZNB4	R&S®ZNB4-B22	9 kHz to 4.5 GHz	1316.0210.02
Extended Power Range for Four-Port R&S®ZNB4	R&S®ZNB4-B24	9 kHz to 4.5 GHz	1316.0233.02
Receiver Step Attenuator, Port 1, for R&S®ZNB8	R&S®ZNB8-B31	9 kHz to 8.5 GHz	1316.0191.02
Receiver Step Attenuator, Port 2, for R&S®ZNB8	R&S®ZNB8-B32	9 kHz to 8.5 GHz	1316.0204.02
Receiver Step Attenuator, Port 3, for R&S®ZNB8	R&S®ZNB8-B33	9 kHz to 8.5 GHz	1316.0162.02
Receiver Step Attenuator, Port 4, for R&S®ZNB8	R&S®ZNB8-B34	9 kHz to 8.5 GHz	1316.0440.02
Extended Power Range for Two-Port R&S®ZNB8	R&S®ZNB8-B22	9 kHz to 8.5 GHz	1316.0227.02
Extended Power Range for Four-Port R&S®ZNB8	R&S®ZNB8-B24	9 kHz to 8.5 GHz	1316.0240.02
Extended Power Range for Two-Port R&S®ZNB20	R&S®ZNB20-B22	100 kHz to 20 GHz	1317.8950.02
Extended Power Range for Four-Port R&S®ZNB20	R&S®ZNB20-B24	100 kHz to 20 GHz	1317.8967.02
Extended Power Range for Two-Port R&S®ZNB40	R&S®ZNB40-B22	10 MHz to 40 GHz	1317.8973.02
Second Internal Generator for R&S®ZNB4/R&S®ZNB8 ¹⁾	R&S®ZNB-B2		1317.7954.02
Second Internal Generator for R&S®ZNB20 ¹⁾	R&S®ZNB20-B2		1317.8980.02
Precision Frequency Reference	R&S®ZNB-B4		1316.1769.02
GPIB Interface	R&S®ZNB-B10		1311.5995.02
Handler I/O (Universal Interface)	R&S®ZN-B14		1316.2459.02
DC Inputs	R&S®ZNB-B81		1316.0004.02
Time Domain Analysis	R&S®ZNB-K2		1316.0156.02
Frequency Conversion ²⁾	R&S®ZNB-K4		1316.2994.02
Intermodulation Measurements ³⁾	R&S®ZNB-K14		1317.8373.02
10 MHz Receiver Bandwidth	R&S®ZNB-K17		1316.1881.02
1 mHz Frequency Resolution	R&S®ZNB-K19		1317.8573.02
USB-to-IEC/IEEE Adapter	R&S®ZVAB-B44		1302.5544.02
Accessories			
Calibration kits (manual calibration)			
Calibration Kit, N, 50 Ω	R&S®ZCAN	0 Hz to 3 GHz	0800.8515.52
Calibration Kit, N (m), 50 Ω	R&S®ZV-Z170	0 Hz to 9 GHz	1317.7683.02
Calibration Kit, N (f), 50 Ω	R&S®ZV-Z170	0 Hz to 9 GHz	1317.7683.03
Calibration Kit, N, 50 Ω	R&S®ZV-Z270	0 Hz to 18 GHz	5011.6536.02
Calibration Kit, 3.5 mm (m), 50 Ω	R&S®ZV-Z135	0 Hz to 15 GHz	1317.7677.02
Calibration Kit, 3.5 mm (f), 50 Ω	R&S®ZV-Z135	0 Hz to 15 GHz	1317.7677.03
Calibration Kit, 2.92 mm, 50 Ω	R&S®ZV-Z229	0 Hz to 40 GHz	5011.6559.02
Calibration Kit, 3.5 mm, 50 Ω	R&S®ZV-Z235	0 Hz to 26.5 GHz	5011.6542.02

Designation	Type	Frequency range	Order No.
Calibration units (automatic calibration)			
Calibration Unit, Four Ports, 3.5 mm (f)	R&S®ZV-Z51	300 kHz to 8 GHz	1164.0515.30
Calibration Unit, Four Ports, N (f)	R&S®ZV-Z51	300 kHz to 8 GHz	1164.0515.70
Calibration Unit, Four Ports, 3.5 mm (f)	R&S®ZV-Z52	10 MHz to 24 GHz	1164.0521.30
Calibration Unit, Two Ports, N (f)	R&S®ZV-Z53	300 kHz to 18 GHz	1164.0473.72
Calibration Unit, Two Ports, 3.5 mm (f)	R&S®ZV-Z53	300 kHz to 24 GHz	1164.0473.32
Calibration Unit, Two Ports, 2.92 mm (f)	R&S®ZV-Z54	10 MHz to 40 GHz	1164.0467.92
Calibration Unit, Eight Ports, N (f)	R&S®ZV-Z58	300 kHz to 8 GHz	1164.0638.78
Calibration Unit, Six Ports, 3.5 mm (f)	R&S®ZV-Z59	10 MHz to 20 GHz	1164.0450.36
Switch matrices			
Switch Matrix, 2 to 5 Ports, 2.92 mm (f) ⁴⁾⁵⁾	R&S®ZV-Z81	50 MHz to 24 GHz	5200.6790.05
Switch Matrix, 2 to 9 Ports, 2.92 mm (f) ⁴⁾⁵⁾	R&S®ZV-Z81	50 MHz to 8,5 GHz	5200.6790.29
Switch Matrix, 2 to 16 Ports, N mm (f) ⁴⁾⁶⁾	R&S®ZV-Z81	10 MHz to 8 GHz	5201.2400.66
Switch Matrix, 4 to 10 Ports, 2.92 mm (f) ⁵⁾⁷⁾	R&S®ZV-Z82	50 MHz to 24 GHz	5200.6860.10
Test cables			
N (m)/N (m), 50 Ω, length: 0.6 m/1 m	R&S®ZV-Z91	0 Hz to 18 GHz	1301.7572.25/.38
N (m)/N (m), 50 Ω, length: 0.6 m/0.9 m	R&S®ZV-Z191	0 Hz to 18 GHz	1306.4507.24/.36
N (m)/3.5 mm (m), 50 Ω, length: 0.6 m/1 m	R&S®ZV-Z92	0 Hz to 18 GHz	1301.7589.25/.38
N (m)/3.5 mm (m), 50 Ω, length: 0.6 m/0.9 m	R&S®ZV-Z192	0 Hz to 18 GHz	1306.4513.24/.36
3.5 mm (f)/3.5 mm (m), length: 0.6 m/1 m	R&S®ZV-Z93	0 Hz to 26.5 GHz	1301.7595.25/.38
3.5 mm (f)/3.5 mm (m), length: 0.6 m/0.9 m/1.5 m	R&S®ZV-Z193	0 Hz to 26.5 GHz	1306.4520.24/.36/.60
2.92 mm (f)/2.92 mm (m), length: 0.6 m/1 m	R&S®ZV-Z95	0 Hz to 40 GHz	1301.7608.25/.38
2.92 mm (f)/2.92 mm (m), length: 0.6 m/0.9 m	R&S®ZV-Z195	0 Hz to 40 GHz	1306.4536.24/.36
Hardware add-ons			
USB Keyboard	R&S®PSL-Z2		1157.6870.04
USB Mouse	R&S®PSL-Z10		1157.7060.03
19" Rackmount Kit	R&S®ZZA-KN5		1175.3040.00

¹⁾ Requires the R&S®ZNB four-port model.

²⁾ Requires the R&S®ZVAB-B44 to control external generators via the IEC/IEEE bus.

³⁾ Requires R&S®ZNB-K4.

⁴⁾ Full crossbar.

⁵⁾ Electronic switches.

⁶⁾ Mechanical switches.

⁷⁾ Requires the R&S®ZNB four-port model for full-crossbar measurements.

Service options		
Extended Warranty, one year	R&S®WE1ZNB	Please contact your local Rohde&Schwarz sales office.
Extended Warranty, two years	R&S®WE2ZNB	
Extended Warranty, three years	R&S®WE3ZNB	
Extended Warranty, four years	R&S®WE4ZNB	
Extended Warranty with Calibration Coverage, one year	R&S®CW1ZNB	
Extended Warranty with Calibration Coverage, two years	R&S®CW2ZNB	
Extended Warranty with Calibration Coverage, three years	R&S®CW3ZNB	
Extended Warranty with Calibration Coverage, four years	R&S®CW4ZNB	

For data sheet, see PD 5214.5384.22 and www.rohde-schwarz.com

Your local Rohde&Schwarz expert will help you determine the optimum solution for your requirements.

To find your nearest Rohde&Schwarz representative, visit

www.sales.rohde-schwarz.com

Service you can rely on

- | Worldwide
- | Local and personalized
- | Customized and flexible
- | Uncompromising quality
- | Long-term dependability

About Rohde & Schwarz

Rohde & Schwarz is an independent group of companies specializing in electronics. It is a leading supplier of solutions in the fields of test and measurement, broadcasting, radiomonitoring and radiolocation, as well as secure communications. Established more than 75 years ago, Rohde & Schwarz has a global presence and a dedicated service network in over 70 countries. Company headquarters are in Munich, Germany.

Environmental commitment

- | Energy-efficient products
- | Continuous improvement in environmental sustainability
- | ISO 14001-certified environmental management system

Certified Quality System
ISO 9001

Rohde & Schwarz GmbH & Co. KG

www.rohde-schwarz.com

Regional contact

- | Europe, Africa, Middle East | +49 89 4129 12345
customersupport@rohde-schwarz.com
- | North America | 1 888 TEST RSA (1 888 837 87 72)
customer.support@rsa.rohde-schwarz.com
- | Latin America | +1 410 910 79 88
customersupport.la@rohde-schwarz.com
- | Asia/Pacific | +65 65 13 04 88
customersupport.asia@rohde-schwarz.com
- | China | +86 800 810 8228/+86 400 650 5896
customersupport.china@rohde-schwarz.com

R&S® is a registered trademark of Rohde & Schwarz GmbH & Co. KG

Trade names are trademarks of the owners | Printed in Germany (ch)
PD 5214.5384.12 | Version 05.00 | January 2013 | R&S®ZNB

Data without tolerance limits is not binding | Subject to change

© 2011 - 2013 Rohde & Schwarz GmbH & Co. KG | 81671 München, Germany



5214538412