

# VMA-Q8X8

## Lab Brick® 8x8 Matrix Attenuator

500 – 6000 MHz Frequency | 90 dB Attenuation Range | 0.1 Step Size | Optional Integrated Server

### Features/Benefits

- Reliable and Repeatable solid state digital attenuation
- Includes Windows and Linux SDK
- Single shot or repeating programmable attenuation ramps
- Programmable fading profiles
- Industry leading size - 3 rack units
- Optional Integrated Windows PC

### Applications

- WiFi 6, WiFi,
- LTE, 5G, 6G
- MIMO, Multipoint Radio Fading Simulators
- Semiconductor Test and Qualification Labs
- Automated Test Equipment (ATE)



The Vaunix Digital Attenuator Matrix Systems are easily customized, bidirectional, non-blocking test instruments. Attenuation matrixes are ideal instruments for mobile operators, Wi-Fi chip manufacturers and radio development teams testing handover and MIMO performance in research labs, product verification and development environments. The matrix attenuator allows the user to direct multiple input signals to multiple outputs while controlling the signal power on all paths.

The VMA-Q8X8SE Attenuator Matrix System is a rack mounted 8 input x 8 output non-blocking test instrument with an optional integrated Windows PC for independent operation. The VMA-Q8X8 provides 90 dB of attenuation control range from 500 to 6000 MHz with a step size of 0.1 dB on all 64 possible path combinations. The attenuators are easily programmable for fixed attenuation, swept attenuation ramps and fading profiles using our highly developed Windows API DLL files and Linux platforms.

The VMA-Q8X8SE is AC powered and controlled through either the USB/Ethernet interface or by accessing the internal Windows PC from the rear of the chassis. RF input signals enter through the rear panel with output signals available on the front panel.

## VMA-Q8X8 Specifications

Parameter	Test Conditions	Min	Typ	Max
Frequency Range (MHz)		500		6000
Impedance ( $\Omega$ )			50	
Channel Inputs/Outputs		8x8 - Bidirectional		
Attenuation Range (dB)		90		
Step Size (dB)		0.1		
Insertion Loss (dB) (Includes theoretical loss of power dividers)	< 2 GHz		30	
	< 4 GHz		32	
	< 6 GHz		35.5	
Attenuation Accuracy (dB)	<30 dB		1	
	<60 dB		2	
	<90 dB		3	
Switching Speed ( $\mu$ s)			2	
Maximum Input Level (dBm)			33	
Input IP3 (dBm)		38	45	
VSWR			1.5:1	

Parameter	Test Conditions/Notes	
Power Requirements	With Integrated PC	110/220 VAC - 70 Watts
	Without Integrated PC	+5V (USB) - 5 Watts
Environmental	Operating Temperature	0 °C to +40 °C
	Relative Humidity (non-condensing)	<95%
Physical Connections	Power Connector	IEC-60320-C13
	Control	USB/Ethernet
	RF Connectors	SMA – female N - female (Optional)
	Mouse/Keyboard <sup>1</sup>	USB
	Display <sup>1</sup>	HDMI
Operating Modes	Manual Attenuation Control Swept Attenuation – uni/bi directional – one time/repeat Profile	
Mechanical	Size (3RU)	17.0 x 13 x 5.23 inches 431.8 x 330.2 x 132.8 millimeters
	Weight	35 lbs 15.9 kg

<sup>1</sup> Mouse, Keyboard and Display are not included. Connection ports are available with integrated server option.

# VMA-Q8X8 Functional Diagram

## 8x8 Matrix

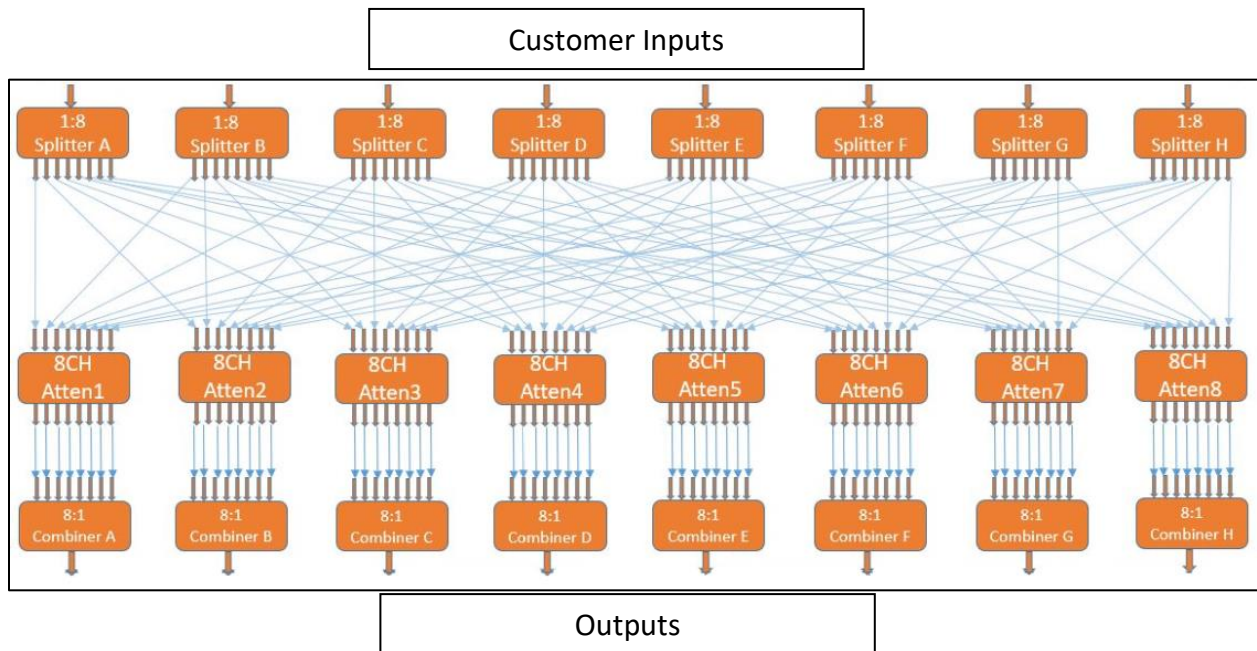

## VMA-Q8X8 Ordering Information

Part Number	Description
VMA-Q8X8	Handover Test System, 8 Input x 8 Output, non-blocking, 500 - 6000 MHz
VMA-Q8X8SE	Handover Test System, 8 Input x 8 Output, non-blocking, 500 - 6000 MHz, Integrated Windows Computer