

## Introduction

The C50/C75 enables HVAC professionals to accurately test and service all residential combustion appliances. The extra large backlit LCD displays two parameters at one time. Easily choose the desired combustion parameter with the rotary selector. The optional printer allows you to print your readings to document your test results.

### Features include

- Choose combustion parameter with a rotary selector
- Measure flue temperature and oxygen (C75: also carbon monoxide)
- Calculates carbon dioxide, gross & net efficiency, and excess air (C75: also carbon monoxide air free)
- Large backlit LCD, 2 line display
- Protected boot with an integral magnet
- 1 ppm accuracy
- Infrared printer port
- User programmable header
- 16 position memory

## Safety Notes



Before using this meter, read all safety information carefully. In this manual the word "**WARNING**" is used to indicate conditions or actions that may pose physical hazards to the user. The word "**CAUTION**" is used to indicate conditions or actions that may damage this instrument.



### WARNING!

*This analyzer extracts combustion gases that may be toxic in relatively low concentrations. These gases are exhausted from the back of the instrument. This instrument must only be used in well-ventilated locations. It must only be used by trained and competent persons after due consideration of all the potential hazards.*

## Controls and Indicators

1. **Display**
2. **Infrared Printer Port**
3.  **ON/OFF:** Turns analyzer ON and OFF.
4.  **Print/Back-Light:** Print data (Press and hold until "PRINTING" appears) / Hold to toggle back-light ON or OFF.
5.  **Pump/Top Line:** Turns pump ON and OFF / Hold to scroll through top line display (also selectable through menu).
6. **Hold/Store:** Freezes reading on display. Entire display flashes. Press and hold for 2 seconds to store data in memory.
7. **Rotary Selector**
8. **Particle Filter**
9. **Water Trap**
10. **Analyzer Connections**

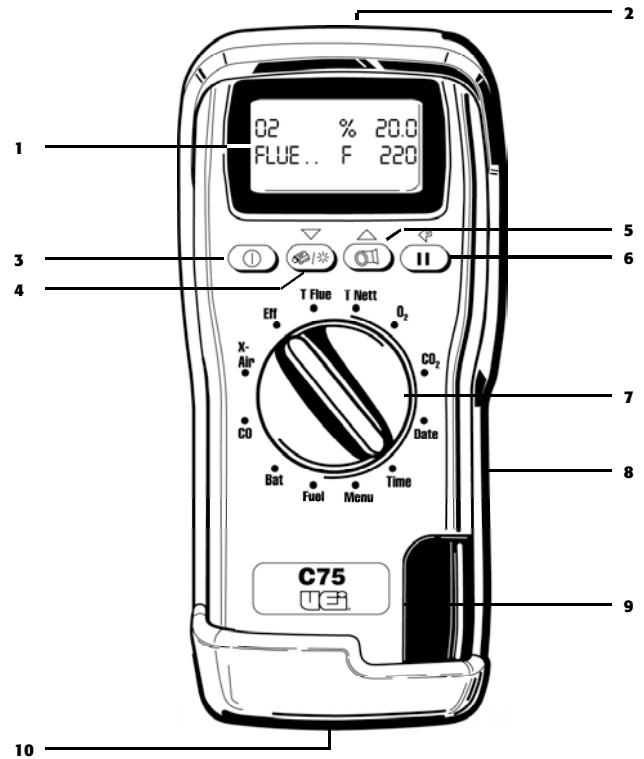

## Main Display Parameters

- O2:** Oxygen reading in percentage (%).
- Tf:** Temperature is measured by the flue gas probe in Centigrade or Fahrenheit. Will show ambient temperature after fresh air calibration and "----" if the flue probe is disconnected.
- CO:** Carbon Monoxide reading displayed in ppm (parts per million). "----" is displayed if there is a fault with the CO sensor or the instrument has not set to zero correctly, switch off instrument and try again.
- COa:** Carbon Monoxide air-free reading referenced to an oxygen level of 0%. Do not confuse this reading with the actual CO reading as detailed above.
- CO<sub>2</sub>:** Carbon Dioxide calculation determined by the type of fuel. This only shows a reading when a combination test is being carried out. "----" is displayed while in fresh air.
- ΔT:** Net temperature calculated by deducting the **AMBIENT** (or **INLET**) temperature from the measured **FLUE** temperature. Displays in either Centigrade (°C) or Fahrenheit (°F) and will display "----" if the flue probe is not connected.
- EFF (G):** Combustion efficiency calculation displayed in percentage. Gross (G) or Net (N) can be set (see MENU). The calculation is determined by the fuel type and uses the calculation in British Standard BS845. The efficiency is displayed during a combustion test, "----" is displayed while in fresh air.
- XAR%:** Excess air calculated from the measured oxygen and type of fuel used. Displays reading during a combustion test. "----" is displayed while in fresh air.
- AMB:** Boiler air **INLET** temperature used to calculate the **NET** temperature

**CO/CO2:** The CO/CO2 ratio is the ratio of measured CO divided by calculated CO2.





It gives an indication of:

- How good a gas sample the instrument is reading
- How clean the boiler is running

For example: A new or clean domestic boiler will display a ratio of less than 0.004, a unit in need of cleaning 0.004 - 0.008 and a unit in need of major overhaul will show greater than 0.008.

This only shows a reading when a combustion test is being carried out. "----" is displayed while in fresh air.

 : Displays the approximate battery level as follows:

- Full battery level 
- Battery at 75% 
- Battery at 50% 
- Battery at 25% 

When the display flashes this, it indicates the batteries are at less than 10% of charge and should be replaced, readings may be affected if the analyzer is used with low power batteries.

**DATE:** Date shown as day, month and year. The order can be changed using the menu function. Date is stored with a combustion test.

**TIME:** The time is shown in hours and minutes, these details are stored with each combustion test.

**NOTE:** When changing the batteries on the instrument the memory will store the date and time for up to one minute, if outside this time it may be necessary to re-enter the details.

## Probe Configuration

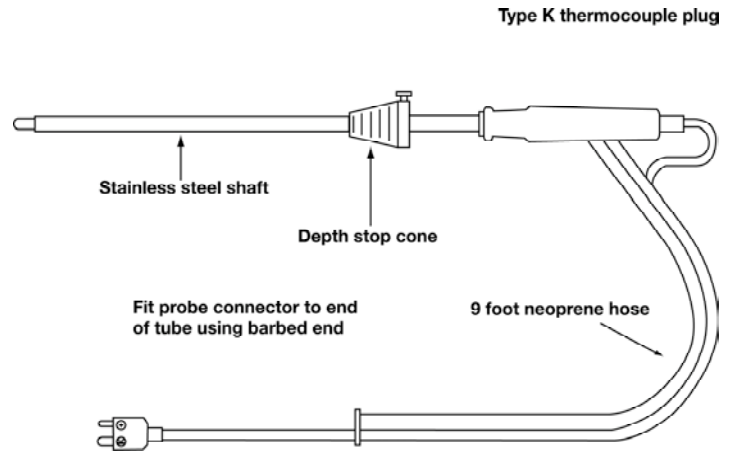

## Operating Instructions

### Before Use Each Time

- The particle filter is not dirty
- The water trap and probe line are empty of water
- All hose and thermocouple connections are properly made
- The flue gas probe is sampling ambient FRESH air
- The water trap is fitted correctly to the instrument
- The flue temperature probe is connected
- The inlet temperature probe is connected if required

Switch ON the instrument by pressing "  "

After switch-on, the analyzer will scroll through the following information while performing a zero countdown:

- Currently Set Date
- Currently Set Time
- Remaining Battery Level
- Fuel Selected
- Model and Analyzer Firmware Level

**NOTE:** The count begins at 59 seconds, and will display the parameter selected with the rotary knob when the sensors are detected as stable. If the analyzer will not auto-zero, the sensors are in need of replacement and the unit should be returned to the authorized service center.

## Analyzer Connections

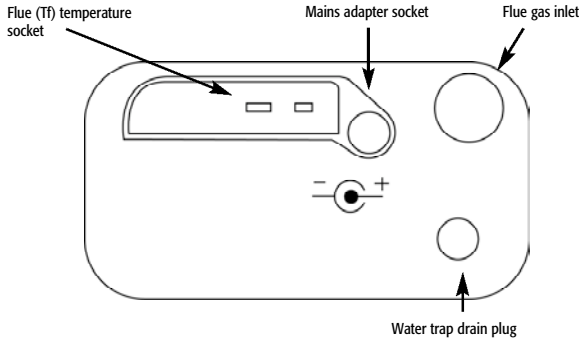

**NOTE:** Take care when inserting the temperature probes as the pins are polarized. Insert with the smaller pin (+) to the right. A view of the sockets is shown below.

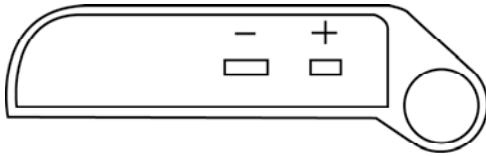

## Automatic Calibration

During this sequence the analyzer pumps fresh air into the Oxygen and CO (C75 only) sensors to allow them to be set to 20.9% and zero respectively. See "Setting Inlet Temperature) for information on options.

## Changing the Display

The parameters on the first line display are selected from the following using the pump key (press and hold for display item to change). Certain items are available on the lower display by selecting with the rotary dial.

Display	Item	Note
NAT GAS*	Fuel selected	Fuel indicator • NAT Gas Natural Gas • Propane • Butane • L Oil Light Oil • LPG Liquid Petroleum Gas
R 0.0000	CO/CO2 ratio	Measured CO divided by calculated CO2
P 0.00	Poison index	CO/CO2 ratio x 100
AMB xx	Ambient temperature (used as inlet temperature for ΔT)	Either instrument internal temperature or stored inlet temperature set during zero countdown
COa	CO air free reading	CO reading adjusted to 0% O2 (C75 only)
O2	O2 Ref	O2% reference value to calculate readings normalized to a set O2 level.
hh:mm:ss*	Time	Currently set time
MM/DD/YY*	Date	Currently set date
CO2*	Carbon Dioxide	Calculated CO2 value
O2*	Oxygen	Measured O2 value
ΔT*	T Nett	Difference between Flue Temp and Ambient (or inlet temperature)
TF*	T Flue	Measured Flue Temperature
η (G, N or C)*	Efficiency	Displays calculated efficiency when O2 values are less than 18%. Displayed as ηN, ηG or ηC as selected by the user.
	Losses (C50 only)	Losses calculated from Oxygen and type of fuel. Displays reading during a combustion test. "----" is displayed while in fresh air.
CO*	Carbon Monoxide (C75 only)	Displays Carbon monoxide values in PPM as CO. Display value in mg/m <sup>3</sup> as COM.
*	Battery level	
λ*	Excess Air	

\*Available on the second line of the display.

## Setting Inlet Temperature

During the automatic calibration sequence the burner INLET (Ti) temperature used in the NET temperature calculation is stored in the analyzer. There are two methods of storing the INLET temperature.

- Without the flue probe connected temperature inside the analyzer is used (ambient temperature).
- If the flue probe is connected the temperature of the probe tip is used. This can be useful when the temperature of the air entering the burner is different than the ambient temperature of the room.

**NOTE:** On ducted inlets, insert the probe tip into the inlet air during the zero countdown. The analyzer will then store this temperature as the ambient (inlet) for use in efficiency calculations. Do not sample flue gas during the zero countdown.



## WARNING!

If the INLET temperature is set incorrectly, then errors will be made in the calculation of net temperature and efficiency.

## Sampling the Flue Gas

Once the automatic calibration procedure has been completed and the specific fuel has been selected (see menu options) the probe can be inserted into the desired sampling point.

It is recommended that the sampling point be located at least two flue diameters downstream of any bend, as close to the source as possible, and that the probe tip is in the center of the flue. With balanced flues and other domestic units the probe should be positioned far enough into the flue so that no air can "back flush" into the probe.

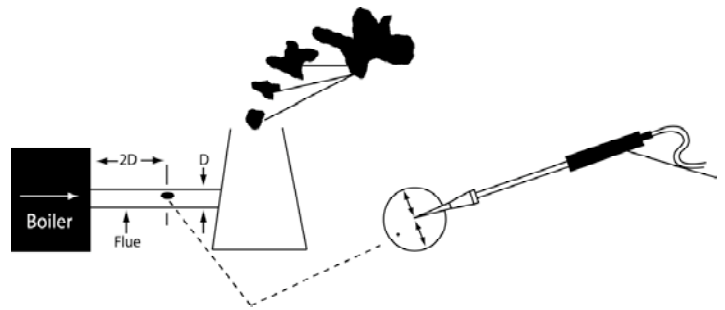

The probe depth stop cone provided with the instrument allows the probe to be used in holes whose diameters range from 1/4 to 4/5 inch (6 mm to 21 mm).

The standard probe is rated at 1112°F (600°C).

**TIP:** To conserve battery power, switch off the pump when you are not taking a measurement. To turn pump ON or OFF press " ".

View data and rotate the dial to see flue changes as you make adjustments. Press "HOLD" first to freeze or store the readings before printing.

## Regular Checks During Sampling

Care must be taken at all times not to exceed the analyzer's operating specifications. In particular ensure the following:

- Do not exceed the maximum temperature of the flue probe
- The analyzer internal temperature does not exceed normal operating range
- DO NOT PLACE THE INSTRUMENT ON A HOT SURFACE
- The water trap is correctly attached at all times - Water condenses in the probe line and can quickly fill the water trap when the probe is moved - Take care and watch the water trap closely
- The particle filter is clean and does not become blocked

## Normal Shutdown Sequence



### WARNING!

Turning the pump off while the probe is in the flue will leave toxic gases inside the analyzer. Once data has been printed or copied it is advisable to purge the unit with fresh air as soon as possible. To do this, with the probe removed from the flue, turn ON the pump. Always allow the readings to return to zero (20.9 for O<sub>2</sub>) prior to shutting the unit off. (C75 only: The meter will not switch off until the CO reading is below 20 ppm)



### WARNING!

The probe will be hot from flue gases

Remove the probe from the flue and allow it to cool naturally. Do not immerse the probe in water, as this will be drawn into the analyzer and damage the pump and sensors. Once the probe is removed from the flue and the readings have returned to ambient levels hold down "Ⓛ" and switch off the analyzer.

The instrument will count down from 30 to switch off.

If you pressed "Ⓛ" by mistake, pressing "||" will return you to normal operation.

## Moving Through the Menu

The options in the menu system are in the following sequence by pressing the down arrow:

**Note:** The menu choices are selected using the text printed on the case above the function keys. The three keys are "△" increases, "▽" decrease and "↵" enter.

### Set Time

1. Press "ENTER"
  2. Use the up and down keys to select the correct time
  3. Press "ENTER" to move to the next digit
- Note:** Time is displayed in military format, example 7:00 pm is 19:00

## Date

1. Press "ENTER"
2. Select desired format for the date display
  - MM-DD-YY for month-day-year
  - YY-MM-DD for year-month-day
  - DD-MM-YY for day-month-year
3. Press "ENTER"
4. Use the up or down arrows to select the correct data
5. Press "ENTER" to move to the next digit and then exit

## TOP LINE

1. Press "ENTER"
  2. Use the up or down arrows to display desired data
  3. Press "ENTER" to save and exit
- Note:** This can also be changed by pressing the "Ⓛ" key when in normal mode more than 4 seconds.

## C ↔ F

1. Press "ENTER"
2. Select degrees displayed in Fahrenheit or Centigrade using the up or down keys
3. Press "ENTER" to save and exit

## CONTRAST

1. Press "ENTER"
  2. Select a value between 02 and 254 for desired contrast using the up or down keys
- Note:** Lower values result in a darker display

## SET FUEL

1. Press "ENTER"
2. Select desired fuel using the up or down keys
  - Choices are Natural Gas, Light Oil, Propane, Butane and Liquefied Petroleum Gas
3. Press "ENTER" to save and exit

## LANGUAGE

1. Press "ENTER"
2. Select the desired language using the up or down keys
3. Press "ENTER" to save and exit

## Header

1. Press up or down and "ENTER" to select desired header.
2. 2 lines of up to 16 characters will appear on the printout.

## Store

1. Log - saves a set of test results when "ENTER" is pressed.
2. DEL ALL - clears all the memory when "YES" and "ENTER" are pressed. **Note:** "ENTER" must be pressed to exit this mode.
3. View
  - The test number appears on the top line
  - Rotate the dial position to displays the stored values
  - Press up or down to display different tests
  - Use "ENTER" to exit this mode

## O<sub>2</sub> Reference

1. This can be set between 0 and 20% to reference your readings to a specific oxygen value.

## N ↔ G ↔ Cond

1. Press "**ENTER**"
2. Select "**N**" for Net, or "**G**" for Gross or "**COND**" to calculate efficiency
  - Gross Efficiency uses the gross calorific value of the fuel and deems that the latent heat of vaporization is lost up the flue of the appliance and is taken as a loss. Gross is used in the UK and USA
  - Net Efficiency uses the net calorific value and assumes the latent heat is not lost up the flue - For Natural gas this efficiency can be 11% higher than the Gross Figure - Net is used in France and Germany
  - COND is for efficiency of condensing appliances
3. Press "**ENTER**" to save and exit

## PPM ↔ MG

1. Press "**ENTER**"
2. Select "**PPM**" for parts per million or "**MG**" for mF/M3 (milligrams per cubic meter) using the up or down keys
3. Press "**ENTER**" to save and exit

## SERVICE

1. The service mode is used for repair and calibration, and should only be entered by authorized service facilities
2. The firmware can be displayed by entering "**2222**" for the code

You may exit the menu at any time by rotating the selector to a different position unless the final logical "**ENTER**" is pressed, no changes are made.

The exception is: STORE DELETE where the "**ENTER**" key must be pressed to confirm the change and exit. If you rotate the dial before pressing "**ENTER**" the instrument will be continuously. You must rotate the dial back to "**MENU**" and press "**ENTER**" before you can continue.

In STORE view mode the rotary dial is used to select the saved parameter to be displayed. Use the "**UP/DOWN**" keys to change the test number. To exit the view mode press "**ENTER**".

## Storing Test Results

At any time during a test you may store the readings in one of the 1 memory positions. Press "**||**" and hold for 2 seconds or more.

## Printing Information

Supplied as an accessory for the analyzer is an infrared thermal printer. Read the manual supplied with the printer prior to operation. Connection to the analyzer is detailed below:

- Infrared thermal printer - this does not require a cable to transmit the data but uses an infrared (IR) link similar to a TV remote control. The IR emitter is positioned on the top of the analyzer and the bottom of the printer. Ensure they are pointing at each other and within 3 feet, with no obstructions in the way. Data may be lost if transmission is interrupted. Keep the analyzer pointing at the printer until the printout has finished.

## Printing A Test

During combustion tests the analyzer can print data on request. With the analyzer showing the data, press and hold the " " push-button until "**PRINTING**" is displayed.

The standard printout is:

\*C75 only

\*\*C50 only

**NOTE:** *Printouts of stored readings will also include the TEST NO. below the header.*

EFF% (G) = gross

EFF% (N) = nett

EFF% (C) = condensing

UEI C75		
16 character header		
16 character header		
503 644 8723		
Date: 06-26-02		
Time: 14:27		
Fuel	NATU	
GAS		
O2	%	20.9
CO2	%	0.0
CO*	PPM	00
COa*	PPM	00
NETT.	F	----
AMB	F	----
EFF%	(G)	----
XAIR	%	----
LOSSES**	%	----
CO/CO2		----
PE %		
O2 ref %		
SMOKE.....		

SMOKE area on printout is for adding data from manual test.

# Combustion

## Combustion Theory

In its simplest form, combustion is the combining of oxygen (O<sub>2</sub>) from the air with hydrogen (H) and carbon (C) from the fuel to form carbon dioxide (CO<sub>2</sub>), water (H<sub>2</sub>O) and energy (light and heat).

Perfect combustion occurs when all of the carbon and hydrogen in the fuel unite with all of the oxygen supplied by the air. This is also referred to as “**STOICHIOMETRIC Combustion**”.

In the real world perfect combustion is nearly impossible to achieve. When tuning a combustion appliance, the goal is to come close to this target to minimize losses and excess emissions. One method is to adjust the amount of air supplied to the combustion area. Too little combustion air, and there will not be enough oxygen to unite with the hydrogen and carbon. This will result in partially burnt fuel, and the creation of carbon monoxide (CO), smoke, and lower efficiency. Too much air will also lower efficiency because the high amount of excess air draws heat away from the combustion area up the flue (increase in  $T_f$ , difference between flue temperature and ambient or inlet). If the amount of excess air is too high, it will also move past the heat exchanger too quickly, resulting in a lower amount of heat transferring to the target.

Below is a graph of typical combustion, showing the point of perfect combustion and an approximate location for ideal combustion. You will notice that by moving farther to the right on the air rich side (high amounts of excess air), the pollutants (CO) don't drop any further. This is where you only lower efficiency. On the left side (fuel rich or starved for air) you see a dramatic increase in carbon monoxide (CO), indicating that a portion of the fuel is not being converted to heat.

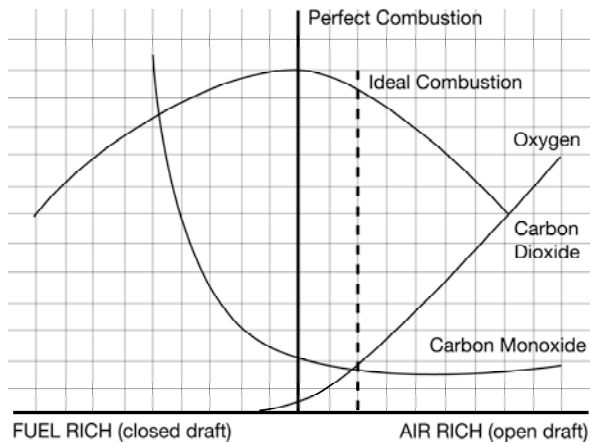

## Combustion Efficiency Calculation

The efficiency calculation is based upon British Standards BS845.

This identifies three sources of loss associated with fuel burning:

<b>Losses due to flue gasses:</b>	Dry Flue gas loss, moisture and hydrogen, sensible heat of water vapor, unburned gas
<b>Losses due to refuse:</b>	Combustible in ash, riddlings and dust
<b>Other losses:</b>	Radiation, convection, conduction other unmeasured losses

Net efficiency calculations assume that the energy contained in the water vapor (formed as a product of combustion and from wet fuel) is recovered and the wet loss term is zero. Gross efficiency calculations assume that the energy contained in the water vapor is not recovered.

Since the fuel air mixture is never consistent there is the possibility of unburned/partially unburned fuel passing through the flue. This is represented by the unburned carbon loss.

Losses due to combustible matter in ashes, riddlings, dust and grit, radiation, convection and conduction are not included.

### Efficiency Calculation:

Known Data - Fuel: Qgr = Gross Calorific Value (kJ/kg)  
 Qnet = Net Calorific Value (kJ/kg)  
 K1 = Constant based on Gross or net Calorific Value  
 $K1g = (255 \times \% \text{ Carbon in fuel})/Qgr$   
 $K1n = (255 \times \% \text{ Carbon in fuel})/Qnet$   
 K2 = % max theoretical CO<sub>2</sub> (dry basis)  
 K3 = % Wet loss  
 H<sub>2</sub> = % Hydrogen  
 H<sub>2</sub>O = % Water

Measured Data: Tf = Flue Temperature  
 Ti = Inlet Temperature  
 O<sub>2m</sub> = % Oxygen in flue gas  
 O<sub>2r</sub> = Oxygen reference %

Calculated Data: Tnet = Net Temperature  
 % CO<sub>2</sub> content in flue gas  
 % Dry flue gas losses  
 % Wet losses  
 % Unburned carbon loss  
 % Efficiency

Tnet = Flue Temperature - Inlet Temperature (or ambient)

Dry flue gas loss % =  $20.9 \times K1 \times (Tnet)/K2 \times (20.9 - O_{2m})$

Wet loss % =  $9 \times H_2 + H_2O/Qgr \times [2488 + 2.1 T_f - 4.2 T_i]$

Simplified =  $[(9 \times H_2 + H_2O)/Qgr] \times 2425 \times [1 + 0.001 Tnet]$

Wet loss % =  $K3 (1 + 0.001 \times Tnet)$

Where K3 =  $[(9 \times H_2 + H_2O)/Qgr] \times 2425$

Net efficiency %	= 100 - dry flue gas losses = 100 - 20.9 x K1n x (Tnet)/K2 x (20.9 - O <sub>2m</sub> )
Gross efficiency %	= 100 - {dry flue gas losses + wet losses} = 100 - {[20.9 x K1g x (Tnet)/K2 x (20.9 - O <sub>2m</sub> )] + [K3 x (1 + 0.001 x Tnett)]}
Excess Air	= [20.9/(20.9 - O <sub>2m</sub> ) - 1] x 100
CO <sub>2</sub> %	= [(20.9 - O <sub>2m</sub> ) x K2/20.9]
Unburned fuel loss %	= K4 x CO/(CO + CO <sub>2</sub> ) <b>Note:</b> CO scaled in %
Where K4	= 70 for coke = 65 for anthracite = 63 for Bituminous coal = 62 for coal tar fuel = 48 for liquid petroleum fuel = 32 for natural gas

The formula for K4 is based on the gross calorific value Q<sub>gr</sub>. To obtain the loss based on net calorific value multiply by Q<sub>gr</sub>/Q<sub>net</sub>. Since this loss is usually small, this conversion has been ignored. This loss is subtracted from the efficiency.

### CO AIR-FREE and Converting to mg/m<sup>3</sup>

Certain standards (ANSI Z21.1) for Carbon Monoxide are stated in terms of air-free. Air-free refers to the concentration of CO in combustion gases undiluted with flue, or other gases containing little CO. This value is computed using an equation that takes into account the O<sub>2</sub> concentration of the flue gas.

If 5% is measured (O<sub>2m</sub>) in the flue then the CO gas value will be recalculated as if 0% were measured. The equation for air-free is as follows:

$$CO_a = CO \text{ PPM} \times [(20.9) / (20.9 - O_{2m})]$$

In our example if a reading of 325 PPM were measured then the air-free value would be calculated as follows:

$$CO_a = 325 \text{ PPM} \times [(20.9) / (20.9 - 5)]$$

$$CO_a = 325 \text{ PPM} \times [(20.9) / (15.9)]$$

$$CO_a = 427$$

We may be given a limit on our furnace by the local authority, which stated that we must not emit more than 400-PPM Carbon Monoxide air-free. In the example we would be breaking the limit and corrective action should be taken to reduce the level of CO.

Air-free values prevent false readings being submitted, e.g. allowing more air into the boiler will increase the oxygen level in the flue and dilute any toxic gas reading. Air-free referencing gives readings as if they were undiluted.

### What Does Oxygen Reference Mean?

Oxygen referencing is required by some regulations in various areas. If a reference value is selected then the CO gas measurement will be displayed with the symbol (n) attached to the reading i.e. PPMn.

If 3% O<sub>2</sub> reference (O<sub>2r</sub>) is selected and 5% O<sub>2</sub> is measured (O<sub>2m</sub>) in the flue then the CO gas value will be recalculated as if 3% were measured. The equation for referencing is as follows:

$$CO \text{ PPMn} = CO \text{ PPM} \times (20.9 - O_{2r}) / (20.9 - 5)$$

In our example if a reading of 95 PPM were measured then the referenced value would be calculated as follows:

$$CO \text{ PPMn} = 95 \text{ PPM} \times (20.9 - 3) / (20.9 - 5)$$

$$CO \text{ PPMn} = 95 \text{ PPM} \times (17.9) / (15.9)$$

$$CO \text{ PPMn} = 107$$

We may be given a limit on our boiler by the local authority which stated that we must not emit more than 100 PPM Carbon Monoxide referenced to 3% Oxygen. In the example we would be breaking the limit and corrective action should be taken to reduce the level of CO.

Oxygen referencing prevents false readings being submitted, e.g. allowing more air into the boiler will increase the oxygen level in the flue and dilute any toxic gas reading. Oxygen referencing gives readings as if they were undiluted.

Oxygen referencing is also referred to as:

- Normalizing
- Diluted and Undiluted readings
- "Air Free" measurements when referenced to zero % oxygen

### Converting ppm to mg/m<sup>3</sup>

To convert Carbon Monoxide to mg/m<sup>3</sup> = CO ppm x 1.25

# Maintenance

## Periodic Service

### **WARNING!**

Repair and service of this instrument is to be performed by qualified personnel only. Improper repair or service could result in physical degradation of the instrument. This could alter the protection from personal injury this meter provides to the operator. Perform only those maintenance tasks that you are qualified to do.

These guidelines will help you attain long and reliable service from your meter:

- Calibrate your instrument annually to ensure it meets original performance specifications
- Keep your instrument dry. If it gets wet, wipe dry immediately. Liquids can degrade electronic circuits
- Whenever practical, keep the instrument away from dust and dirt that can cause premature wear
- Although your instrument is built to withstand the rigors of daily use, it can be damaged by severe impacts. Use reasonable caution when using and storing the meter

## Cleaning

Periodically clean your instruments case using a damp cloth. **DO NOT** use abrasive, flammable liquids, cleaning solvents, or strong detergents as they may damage the finish, impair safety, or affect the reliability of the structural components.

## Battery Replacement

This meter has been designed for use with both alkaline and rechargeable Nickel Metal Hydride (NiMH) batteries. No other types are recommended. The analyzer is supplied with 4 "AA" size alkaline batteries. These should be installed into the instrument as shown below (Fig 1) and indicated on the back of the unit.

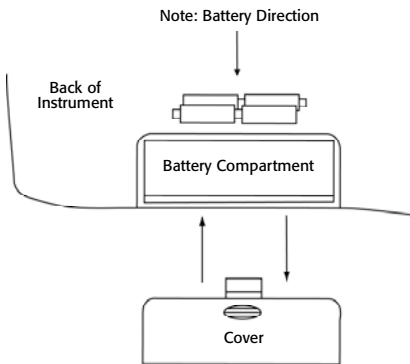

(Fig 1)

### **CAUTION!**

Take great care when installing the batteries to observe correct polarity. Always check the meter for operation immediately after installing new batteries.

## Using Re-Chargeable Batteries

The battery charger must only be used when NiMH batteries are fitted.

Alkaline batteries are not re-Chargeable. Attempting to recharge alkaline batteries may result in damage to the product and may create a fire risk.

## Charging

Ensure that you use the correct charger. This unit uses a 9V DC regulated charger.

Ensure that the batteries are fitted in the correct manner, and then charge for at least 16 hours. Subsequent charges should be overnight. NiMH batteries may be charged at any time, even for short periods to conduct testing.

### **WARNING!**

Under **NO** circumstance should you expose batteries to extreme heat or fire as they may explode and cause injury. Always dispose of old batteries promptly in a manner consistent with local disposal regulations.

## Emptying and Cleaning the In-line Water Trap

The in-line water trap should be checked and emptied on a regular basis. Water vapor will condense in the probe line, which may cause the water trap to fill suddenly if the probe is moved. Care should be taken at all times.

Carefully remove the rubber plug from the bottom of the water-trap housing. Dispose of the condensate in a suitable drain, care must be taken as it could be acidic.

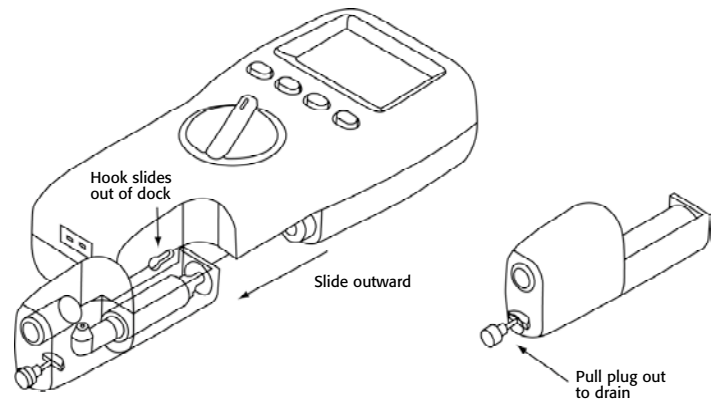

If condensate spills onto the skin or clothing, clean off immediately using fresh water, seek medical advice if problems occur. Ensure plug is replaced before performing combustion tests.

## Changing the Particle Filter

This is a very important part of the analyzer and should be changed regularly. It prevents dust and dirt particles from entering the pump and sensors that will cause damage. The filter **MUST** be changed when it appears discolored.

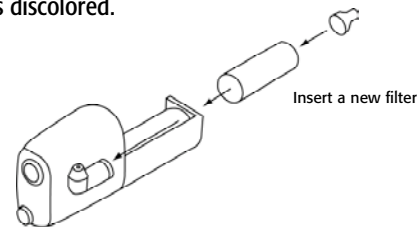

Remove water-trap assembly from the analyzer as shown above. Remove the filter and plastic holder from the housing. Discard the filter element but keep the holder to fit to the new filter. Clean the inside of the filter housing with a suitable soft cloth. Fit the holder onto the new filter element and then insert into the housing. Refit the housing onto the analyzer.

## Annual Re-Calibration

While the sensor has an expected life of more than two years in normal use it is recommended that the analyzer is re-calibrated at least annually. This is so that long-term drift on the sensor and electronics can be eliminated. Local regulations may require more frequent re-calibration and users should check with appropriate authorities to ensure the comply with relevant guidelines.

## Troubleshooting

The following is a list of problems that may occur on the instrument through its operating life. If the cause of the fault is not easy to identify then we advise you to contact UEi Technical Support line at (800) 547-5740.

Fault Symptom	Causes
<ul style="list-style-type: none"> <li>Oxygen too high</li> <li>CO<sub>2</sub> too low</li> </ul>	Air leaking into probe, tubing, water trap, connectors or internal to instrument Oxygen cell needs replacing
<ul style="list-style-type: none"> <li>Oxygen error "----"</li> <li>CO sensor error "----"</li> </ul>	Instrument has been stored in a cold environment and is not at normal working temperature Oxygen cell or CO sensor needs replacing
<ul style="list-style-type: none"> <li>Display flashes</li> </ul>	Display "HOLD" is activated Battery level is low
<ul style="list-style-type: none"> <li>CO is displayed as COm</li> </ul>	Units selected for CO are mg/M3
<ul style="list-style-type: none"> <li>Analyzer not running on mains adapter</li> </ul>	AC charger not giving correct output
<ul style="list-style-type: none"> <li>Analyzer does not respond to flue gas</li> </ul>	Particle filter blocked Probe or tubing blocked Pump not working or damaged with contaminant's
<ul style="list-style-type: none"> <li>Net temperature or efficiency calculation incorrect</li> </ul>	Inlet (or ambient) temperature set wrong during automatic calibration Incorrect efficiency type selected (net vs. gross)
<ul style="list-style-type: none"> <li>Flue temperature readings erratic</li> </ul>	Temperature plug reversed in socket Faulty connection or break in cable or plug
<ul style="list-style-type: none"> <li>X-Air, EFF, COa or CO2 display (---)</li> </ul>	Oxygen reading is above 18%
<ul style="list-style-type: none"> <li>Meter just continually beeps</li> </ul>	Turn dial back to "MENU" and press "ENTER".

## Electromagnetic Compatibility (EMC)

This product has been tested for compliance with the following generic standards:

**EN 50081-1, EN 50082-1**



and is certified to be compliant.

The European Council Directive 89/336/EEC requires that electronic equipment does not generate electromagnetic disturbances that exceed defined levels and has an adequate level of immunity to enable it to be operated as intended.

Since there are many electrical products in use that pre-date this Directive and may emit electromagnetic radiation in excess of the standards defined in the Directive there may be occasions where it would be appropriate to check the analyzer prior to use. The following procedure should be adopted.

- Go through the normal start up sequence in the location where the equipment is to be used
- Switch on all localized electrical equipment that might be capable of causing interference
- Check that all readings are as expected (a level of disturbance in the readings is acceptable)
- If not, adjust the position of the instrument to minimize interference or switch off, if possible, the offending equipment for the duration of the test

At the time of writing this manual (July 200) Kane International Ltd is not aware of any field based situation where such interference has ever occurred and this advice is only given to satisfy the requirements of the Directive.

## Specifications

Parameter	Resolution	Accuracy	Range
<b>Temp Measurement</b>			
Flue temperature	1.0° F/C	±5°F (2.0°C) ±0.3% reading	32 - 1112°F 0 - 600°C
Inlet temperature	1° F/C	±1° F/C ±0.3% reading	32 - 212°F 0 - 100°C
Temp (Nett) <sup>2</sup>	1.0° F/C	±5°F (2°C) ±0.3% reading	32 - 1112°F 0 - 600°C
<b>Gas Measurement</b>			
Oxygen	0.1%	±0.2% <sup>1</sup>	0 - 21%
*Carbon Monoxide	1 ppm	±10 ppm <100 ppm <sup>1</sup> ±5% reading	0 - 1000 ppm
Carbon Dioxide <sup>2</sup>	0.1%	±0.3% reading	0 - 30%
Efficiency <sup>2</sup>	0.1%	±1.0% reading	0 - 99.9%
Excess Air <sup>2</sup>	0.1%	±0.2%	0 - 250%
<b>Pre-programmed fuels</b>	Natural gas, Light Oil, Propane, Butane, LPG		
<b>Dimensions</b>			
Weight	1 kg. / 2.2 lb.		
Handset	200mm/7.9" x 45mm/1.8" x 90mm/3.5"		
Probe	(L) 300mm/7.9" x (Dia) 6mm/0.25" with 200mm/7.8" long stainless steel shaft, type K thermocouple and 3m/6ft long neoprene hose		
<b>Ambient operating</b>	+32° - 104°F (0° - 40°C) 10% to 90% RH non-condensing		
<b>Battery life range</b>	4 "AA" cells >8 hours using Alkaline "AA" cells		
<b>AC adapter (optional)</b>	Input: 110 V AC / 220 V AC nominal Output: 10 V AC off load		

<sup>1</sup>Using dry gases at STP

<sup>2</sup>Calculated

\*C75 only



# **C50/C75**

## **Combustion Analyzer**

### **Limited Warranty**

The C50/C75 is warranted to be free from defects in materials and workmanship for a period of three years (two years on sensors) from the date of purchase. If within the warranty period your instrument should become inoperative from such defects, the unit will be repaired or replaced at UEi's option. This warranty covers normal use and does not cover damage which occurs in shipment or failure which results from alteration, tampering, accident, misuse, abuse, neglect or improper maintenance. Batteries and consequential damage resulting from failed batteries are not covered by warranty.

Any implied warranties, including but not limited to implied warranties of merchantability and fitness for a particular purpose, are limited to the express warranty. UEi shall not be liable for loss of use of the instrument or other incidental or consequential damages, expenses, or economic loss, or for any claim or claims for such damage, expenses or economic loss. A purchase receipt or other proof of original purchase date will be required before warranty repairs will be rendered. Instruments out of warranty will be repaired (when repairable) for a service charge. Return the unit postage paid and insured to:

**1-800-547-5740 • FAX: (503) 643-6322**

**Service: (800) 308-7709**

**[www.ueitest.com](http://www.ueitest.com) • Email: [info@ueitest.com](mailto:info@ueitest.com)**

This warranty gives you specific legal rights. You may also have other rights which vary from state to state.