

Cable Length Meter

INSTRUCTION MANUAL

ENGLISH

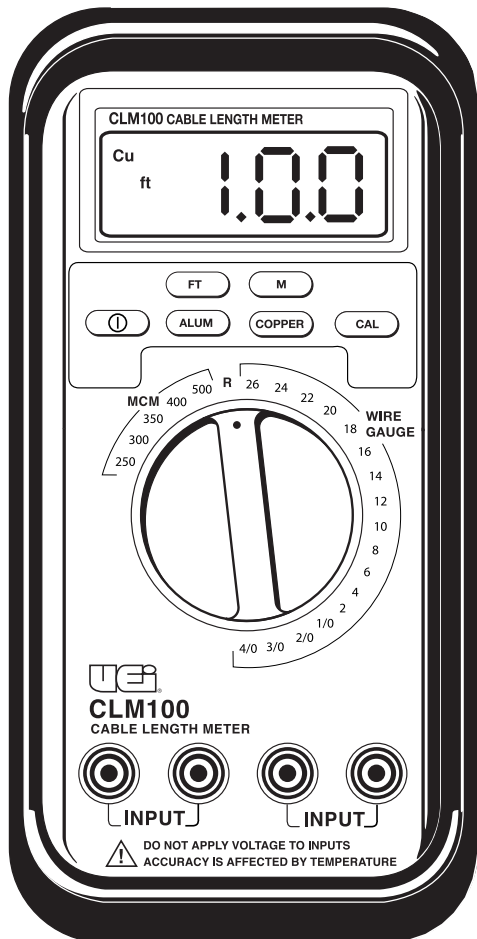

1-800-547-5740

www.ueitest.com • email: info@ueitest.com

TABLE OF CONTENT

Introduction	3
Features icludes	3
Safety Tips	3
International Symbol	3
Instructions	4-5
Calibration Procedures	4
Measuring Length of Wire	4
Low Battery Indication	5
Measuring Resistance	5
Specifications	6
Operational Hints	7
Warranty	8
Disposal	8
Cleaning	8
Storage	8

INTRODUCTION

The CLM100 Cable Length Meter is ideal for measuring cable length on the spool or in existing conduits. Includes test leads, copper calibration bar, an abrasive pad for removing oxidation and carrying case.

Features include

- 3 digit display with enunciators
- Measures in FEET (ft) or METERS (m)
- Measures COPPER (CU) or ALUMINUM (AL) wire
- Resistance range for milliohm measurements
- Automatic temperature compensation
- User calibration mode. Calibration standard included
- Auto power off

WARNING!











Make sure wire under test is not energized. Never apply voltage to inputs.

NOTE: Temperature affects accuracy of readings. Please see accuracy specifications. For best results, allow the CLM100 to attain the same ambient temperature as the wire under test. The length of time this will take depends on the ambient temperature. Typically it will take 10 to 15 minutes for the CLM100 to attain equal ambient temperature.

SAFETY TIPS

Before using this meter, read all safety information carefully. In this manual the word **“WARNING”** is used to indicate conditions or actions that may pose physical hazards to the user. The word **“CAUTION”** is used to indicate conditions or actions that may damage this instrument.

INTERNATIONAL SYMBOLS

 Dangerous Voltage	 Ground
 AC Alternating Current	 Warning or Caution
 DC Direct Current	 Double Insulation (Protection Class II)
 Either AC or DC	 Fuse
 Not Applicable to Identified Model	 Battery

INSTRUCTIONS

Calibration Procedures

1. Turn the CLM100 on by depressing the green on/off button
2. Insert the black test leads into one pair of input jacks and the red test leads into the other pair of input jacks. (Ignore the gray marking on the banana plug.) This is very important to ensure that the meter works correctly. If black and red test leads are mixed the unit will give a false reading. (Fig 1)

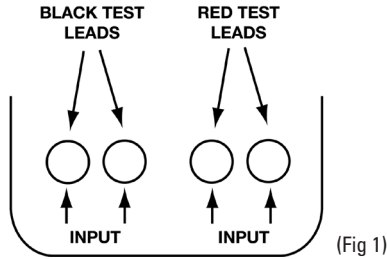

3. Connect the Kelvin clips to the calibration standard. Make sure the clips are as close together as possible. (Fig 2)

NOTE: Make sure the calibration standard is clean. The Kelvin clips must be connected across the diameter of the standard. Use the abrasive pad to clean the calibration standard.

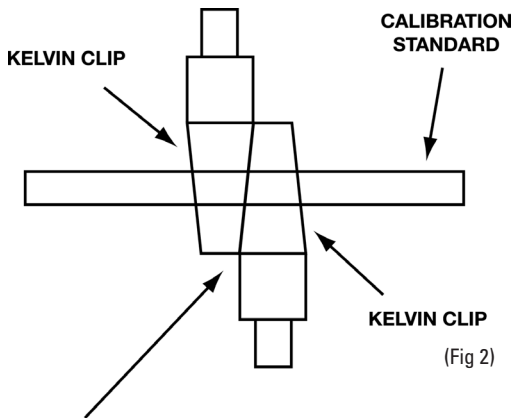

NOTE: Make sure clips are as close together as possible. Use the tips of the Kelvin clips when performing measurements on small diameter wire.

4. Press and hold the "CAL" button until all segments in the display illuminate. This completes the calibration procedure and will ensure all measurements are as accurate as possible.
5. Disconnect the leads from the standard.

Measuring Length of Wire

1. Turn the CLM100 on and perform the calibration procedure.
2. Allow the CLM100 to attain the same temperature as the wire under test.

NOTE: Temperature affects accuracy of readings. Please see accuracy specifications. For best results, allow the CLM100 to attain the same ambient temperature as the wire under test.



WARNING!

Make sure wire under test is not energized. Never apply voltage to inputs.

3. Strip the insulation back on each end of the wire being tested.

NOTE: Make sure both ends of the wire under test are clean and the conductor is fully exposed. The insulation must be stripped away so the Kelvin clips can be connected across the diameter of the wire. Use the abrasive pad to clean the wire ends.

4. Using the selector on the CLM100, turn to the size of wire under test.
5. Press the **"COPPER"** button if copper wire is being tested.
The **"CU"** enunciator will illuminate in the top left corner of the display.
6. Press the **"ALUM"** button if aluminum wire is being tested.
The **"AL"** enunciator will illuminate in the top left corner of the display.
7. Press the **"FT"** button if you require readings to be in feet.
The **"ft"** enunciator will illuminate in the display.
8. Press the **"M"** button if you require readings to be in meters.
The **"m"** enunciator will illuminate in the display.
9. Connect a Kelvin clip to one end of the wire and the other Kelvin clip to the other end of the wire.
10. Read the length of wire directly from the display.
Please note the **"k"** enunciator illuminates if measurements are at or above 1000 feet/meters.
11. Disconnect the test leads from the unit when not in use.

Low Battery Indication

The **"BAT"** enunciator will illuminate in the lower left side of the display to indicate battery voltage is low. The battery should be changed immediately to ensure proper function and accuracy. Only alkaline 9 Volt batteries should be used.

Measuring Resistance

1. If the resistance to be measured is wire, follow steps 1 through 3 under "Measuring Length of Wire." Then follow steps 2 and 3 below. If a discrete resistor is being measured, turn the cable length meter on and perform the calibration procedure.
2. Using the selector on the CLM100, turn to **"R"** on the dial.
3. Read the resistance of the wire directly from the display.

SPECIFICATIONS

Measurement Range:	15 to 30,000 feet 26ga to 4/0ga 250MCM to 500MCM
Accuracy:	Ambient Temperature: 65° to 75°F < 30ft: ±6 LSD > 30ft: ±(2% of reading + 3 LSD)
	Ambient Temperature: <65° and >75°F < 30ft: ±6 LSD > 30ft: ±(3% of reading + 3 LSD) LSD = least significant digit
Resistance:	0 to 65Ω (±2% of reading)
Operating Temperature:	32° to 104°F
Operating Humidity:	20% to 80% RH
Storage Temperature:	0° to 120°F
Auto power off:	After 5 minutes (approx.)
Battery Life:	Depends on use. Typically 40 hours. Extended measurements times can lower battery life to no less than 6 hours.

WARNING: This meter is NOT designed to measure less than 15 feet of cable.

OPERATIONAL HINTS

- Never apply voltage to the inputs.
- Temperature affects readings. Allow the CLM100 to attain the ambient temperature of the wire under test.
- Use a 9 Volt alkaline battery only
- Use the test leads that came with the unit only. Other leads will not work.
- Ensure that the test leads are clean and in good working order.
- Use an abrasive pad similar to the one provided to ensure the wire under test is clean and free of oxidation
- Ensure that insulation is stripped adequately from both ends of the wire under test. This will enable measurements to be accurate.
- Ensure that the alligator clips are connected across the diameter of the wire under test.
- When measuring wire for insertion into conduit, add extra wire to compensate for the accuracy of the meter. For example, 205 feet of wire is needed to run inside a piece of conduit that is 200 feet long. (This would allow 2.5 feet on each end to attach the wire.) At 205 feet and 70°F, the cable length meter has an accuracy of ± 7 feet. In this case it would be safer to measure out 212 feet of wire. This would ensure that enough wire is available for the application.

WARRANTY

The CLM100 is warranted to be free from defects in materials and workmanship for a period of five years from the date of purchase. If within the warranty period your instrument should become inoperative from such defects, the unit will be repaired or replaced at UEI's option. This warranty covers normal use and does not cover damage which occurs in shipment or failure which results from alteration, tampering, accident, misuse, abuse, neglect or improper maintenance. Batteries and consequential damage resulting from failed batteries are not covered by warranty.

Any implied warranties, including but not limited to implied warranties of merchantability and fitness for a particular purpose, are limited to the express warranty. UEI shall not be liable for loss of use of the instrument or other incidental or consequential damages, expenses, or economic loss, or for any claim or claims for such damage, expenses or economic loss. A purchase receipt or other proof of original purchase date will be required before warranty repairs will be rendered. Instruments out of warranty will be repaired (when repairable) for a service charge. Return the unit postage paid and insured to:

1-800-547-5740 • FAX: (503) 643-6322
www.ueitest.com • Email: info@ueitest.com

This warranty gives you specific legal rights. You may also have other rights which vary from state to state.

DISPOSAL

 **CAUTION:** This symbol indicates that equipment and its accessories shall be subject to separate collection and correct disposal.

CLEANING

 Periodically clean your meters' case using a damp cloth. **DO NOT** use abrasive, flammable liquids, cleaning solvents, or strong detergents as they may damage the finish, impair safety, or affect the reliability of the structural components.

STORAGE

Remove the batteries when instrument is not in use for a prolonged period of time. Do not expose to high temperatures or humidity. After a period of storage in extreme conditions exceeding the limits mentioned in the General Specifications section, allow the instrument to return to normal operating conditions before using it.