

TECHNI-PRO

ISO 9001
BUREAU VERITAS
Certification

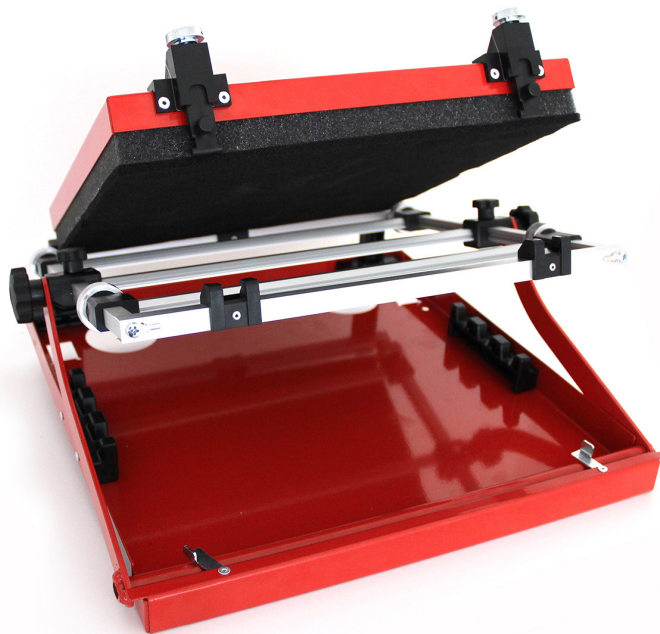

ISO 13485
BUREAU VERITAS
Certification



PCSA CIRCUIT BOARD HOLDER

ESD Safe in accordance with regulations
IEC 61340-5-1:2016 and IEC 61340-2-3:2016

PCSA Circuit board holder



Models

TECHNI-PRO

PCSA-1N

work surface: 280 mm x 220 mm

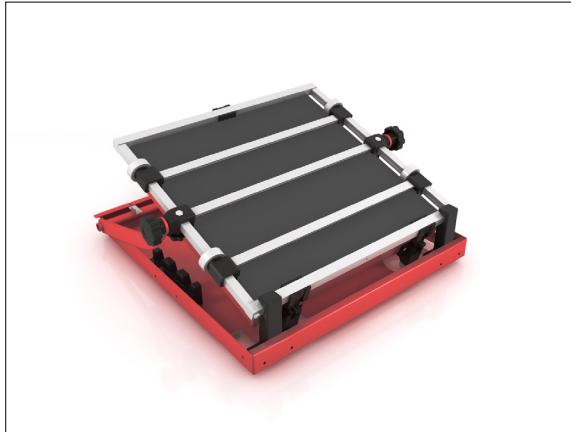

Additional splint: **BS-PCSS-1**
Additional foam: **PCSA-1.2**

PCSA-2N

work surface: 510 mm x 220 mm

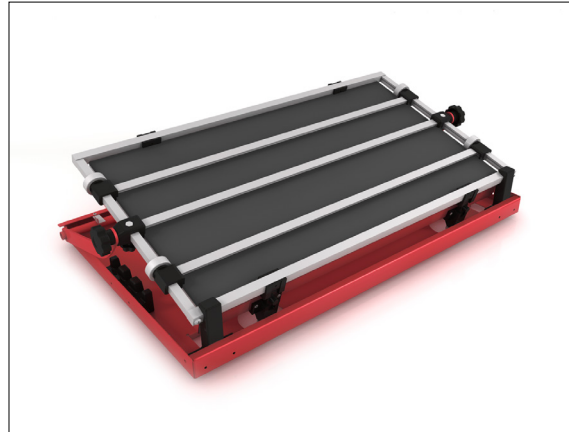

Additional splint: **BS-PCSS-2-4**
Additional foam: **PCSA-2.2**

PCSA-4N

work surface: 510 mm x 350 mm

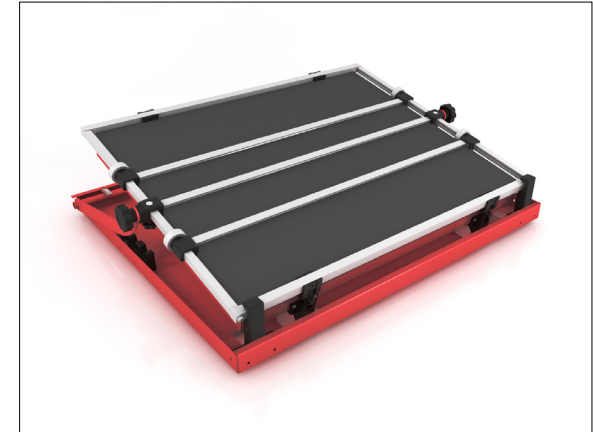

Additional splint: **BS-PCSS-2-4**
Additional foam: **PCSA-4.2**

Standard configuration:

- 2 splints (sliding rail)
- 1 central removable middle bridge
- 1 cover
- 1 foam rubber

Important notes:

1. Do not force the closing of the top cover with your hands

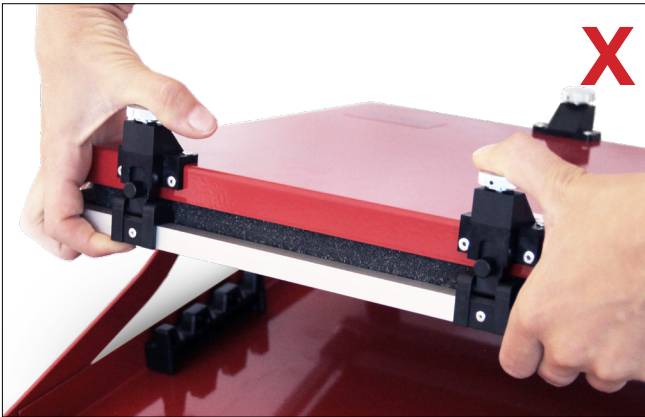

2. Do not force the closing of the top cover without adjusting the height first, based on component dimension



PCSA Circuit board holder



Combinations and work surface in mm

TECHNI-PRO

	PCSA-1N	PCSA-2N	PCSA-4N
BRIDGE = 0 SPLINT = 2			
BRIDGE = 1 SPLINT = 2			
BRIDGE = 1 SPLINT = 4			

FEATURE:

- Circuit board holders of the PCSA series are the ideal tool for fitting circuit boards with components. The holder can easily be demounted in single parts and be reassembled in different combinations.
- The standard models PCSA-1N/2N/4N are equipped with 1 removable middle bridge and 2 adjustable splints. Thus two work areas can be created.
- Any circuit board holders can be fitted with additional subdivisors (4 for PCSA-1N/2N and 6 for PCSA-4N). That way small circuit boards can be used on several levels.

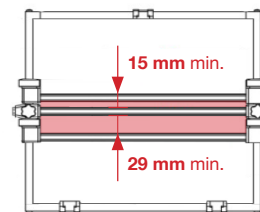

Minimum area
(for all PCSA models)

BRIDGE = 1 SPLINT = 6

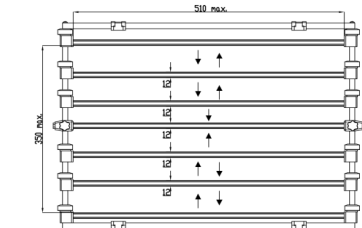

PCSA Circuit board holder



How to use PCSA detachable assembly jigs for pc board

TECHNI-PRO

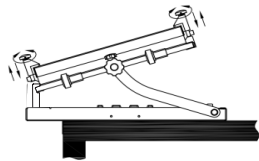

PC Assembly jig with component-press lid closed screwed or clamped to work-top, in relation to the height of the components.

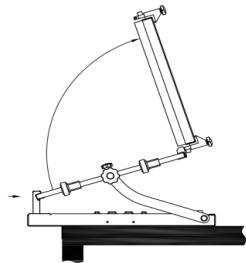

Foam rubber-lined lid for holding components in place. May be raised by applying pressure to front buttons.

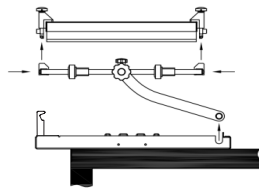

Easy to unslot and detach various parts. (Frame-PC holder unit-component-Press Lid).

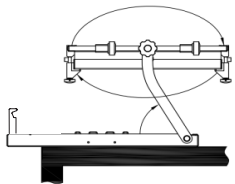

PC board assembly jig can be raised by turning lateral knobs. Self-adjustment to frame at right working angle, after unit raising.

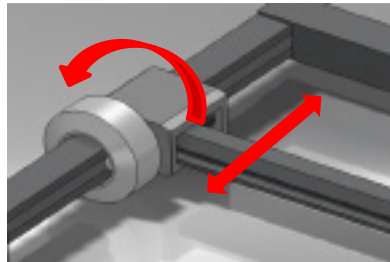

Sliding rails may be positioned by means of self-locking sleeves. A system of springs makes it possible to insert and remove printed circuit boards without changing position of sleeves.

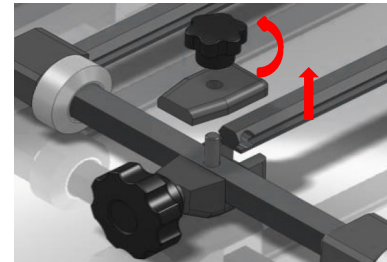

Turn the knob to remove the middle bridge.

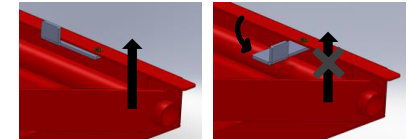

Moveable couplings, located on the rear side of the assembly jigs for attaching the PC assembly jig to the frame. These couplings keep the PC assembly jig from detaching from the frame.

Using pc board assembly jig in vertical position

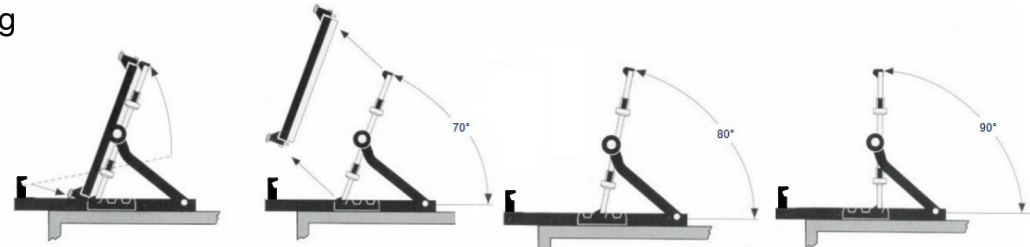

Positioning of the lower corners of the PC Assembly Jig in the toothed guides located on the frame.

Positioning at 70° angle

Positioning at 80° angle

Positioning at 90° angle

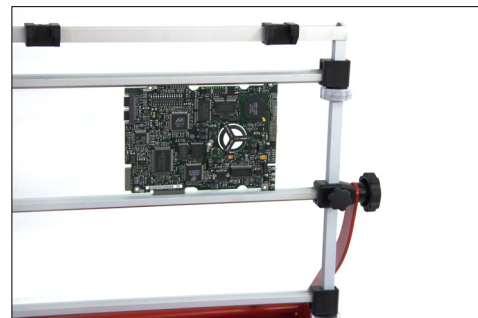

Practical use of PC Assembly Jig with PC Board in place.



Unsoldering of components carried out with PC Assembly Jig in vertical positions.



PCSA-1N

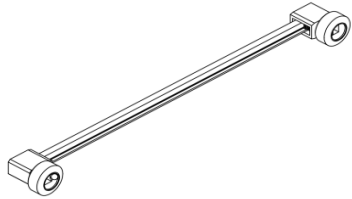

BS-PCSS-1: Sliding rail

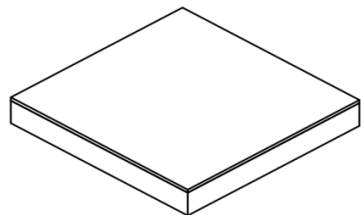

PCSA-1.2: Foam

PCSA-2N / PCSA-4N

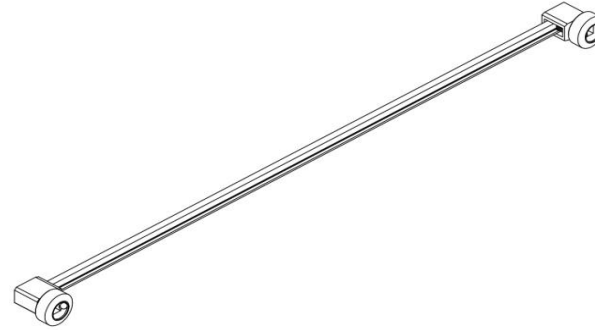

S-PCSS-2-4: Sliding rail

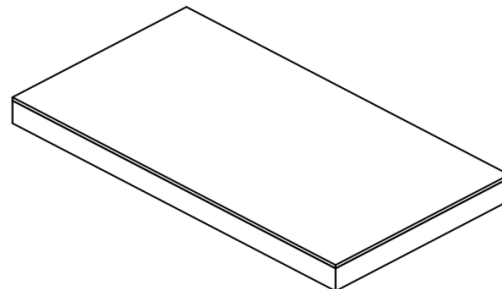

PCSA-2.2: Foam

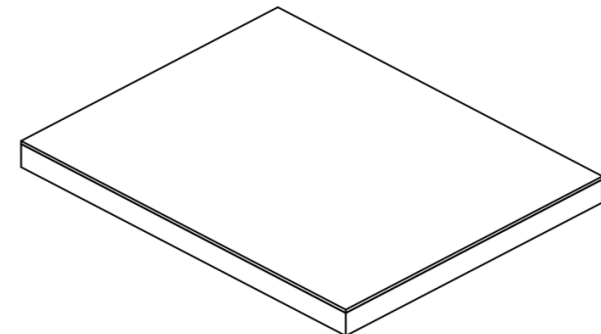

PCSA-4.2: Foam

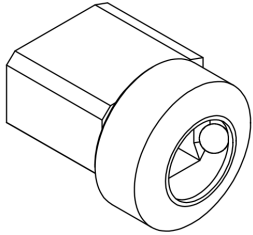
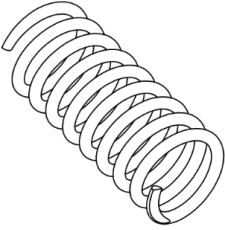
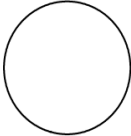
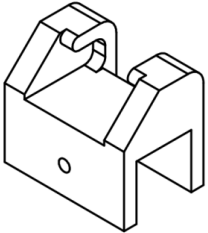
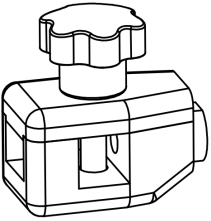
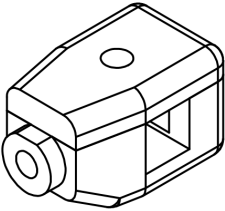
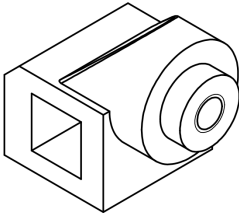
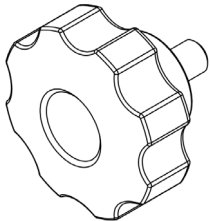
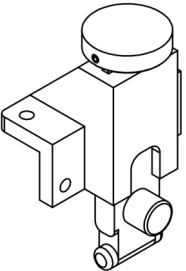
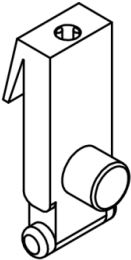
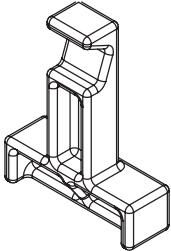
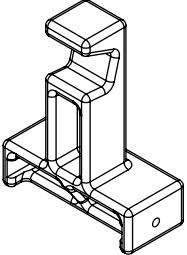

PCSA-1 PCSA-2 PCSA-4 (old models) PCSA-1N PCSA-2N PCSA-4N (new models)			
			
BS-PCSS-NBS: Sliding block	MO-BS-PCSS: Spring	SF-BS-PCSS: Ball diam. 5 mm	IN-PCSS: Cover support
			
AC-PCSA: Bush-Knob-Screw	SR-PCSA: Bush	SR-PCSS: Bush (old)	PR-PCSS: Knob
			
RIC-PCSA-N1: Pivot	SC-PCSS: Cover clip lever	old version - <i>only for PCSA-1</i> SC-PCSA: Frame holder	new version - for all models (<i>not for PCSA-1</i>) SCN-PCSA: Frame holder

