

TECHNI-PRO

Product Data Sheet

High Precision Cutters

TNP-CTR-HP-ES5235

Product type: High Precision Cutters

Made in: Italy

Description: The 5235 is a high precision cutter belonging to the special cutter family. The 15-degree angled micro short tips provide the best advantage to access micro areas. The full-flush cutting edge is suitable to perform very clean cuts on small size material. The 5235 is equipped with an ESD Ergo-tek slim handle which allows an excellent grip, suitable to environments and to components susceptible to electrostatic discharge. The blades are hardened to 67HRC hardness. 5235 is also equipped with an anti-shock system that considerably reduces mechanical shock to the component and prevents the blades from breakage

Head description: Oblique Micro Tip

Cutting edges: Full-Flush

Cutting capacity: soft wire 0.35 mm (27 AWG)

Body material: High carbon-chromium low alloy steel (100Cr6)

Handle coating: ESD safe - Thermoplastic Elastomer TPE + Polypropylen compound PP

Picture:



Dimensions:
OAL 125 mm – 4.921 inch
Width 60 mm – 2.362 inch
Height 18 mm – 0.709 inch

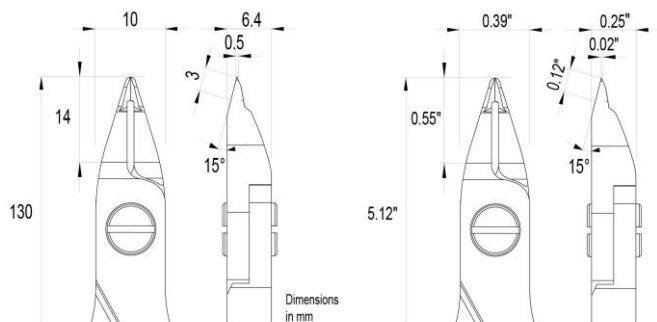

TECHNI-PRO

Production supplies that **WORK** as hard as you do

Techni-PRO is a TestEquity private label brand featured on:

www.testequity.com/brand/techni-pro
www.techni-tool.com/brand/techni-pro
www.jensentools.com/brand/techni-pro