

CORDLESS TOOLS INDUSTRIAL

ISO 9001



Certificate TW04/02301

INNOVATIVE BRUSHLESS MOTOR ASSURE
THE BEST AND RELIABLE QUALITY



SUMAKE®

MAKE JOBS BETTER THAN EVER



SUMAKE COMPANY PROFILE

Sumake is a manufacturer and exporter specializing in professional high quality pneumatic tools, compressors and accessories suited to a wide range of applications including industrial and automotive.

We are an innovative company.

As a result of constant research and investment we keep at the forefront of current technology and design, thus providing energy efficient, durable and reliable products to industrial markets around the world.

We offer a wide, comprehensive range of CE certified tools and accessories including: Brushless Electric Screwdrivers, Transducerized DC Tools, Torque Readout and Screw Counting System, just to name a few.

Certified to ISO 9001 we run efficient well organized computerised Q.C. ensure we meet quality, packaging and delivery benchmarks.

We guarantee our customers complete spare parts back up for everything we provide.

Superior service to our customers is not a goal, it's a reality.

Sumake, partners in business.



SUMAKE has attended many international exhibitions and is known for a variety of high-end innovations with vivid posters.

Our outstanding showcase is not only eye-catching but also provides hands-on experience for visitors.

INDEX

PISTOL TYPE



10.8V FULL AUTO SHUT-OFF CORDLESS SCREWDRIVER [P1](#)

STRAIGHT TYPE



7.2V & 10.8V FULL AUTO SHUT-OFF CORDLESS SCREWDRIVER [P2 ~ 3](#)

SHUT-OFF



18V FULL AUTO SHUT-OFF CORDLESS ANGLE WRENCH [P4 ~ 5](#)

SHUT-OFF & SEMI AUTO



18V BRUSHLESS FULL AUTO SHUT-OFF & SEMI-AUTO SCREWDRIVER [P6 ~ 7](#)

MECHANICAL PULSE



14.4V REMOTE CONTROL TYPE SCREWDRIVER / WRENCH [P8](#)

BATTERY & CHARGER



LITHIUM ION BATTERY & CHARGER [P9](#)

10.8V BRUSHLESS FULL AUTO SHUT-OFF CORDLESS SCREWDRIVER

NEW

Features :

- High Accuracy Assurance:** $\pm 3\%$ deviation of torque, assure the best quality.
- Ideal for limited space or areas** where cables and hoses impede handing flexibility e.g., car interior electrical, car assembly, factory assembly etc.
- High mobility and lightweight ergonomic design,** easy to carry and operate.
- Dormancy Mode:** Once the screwdriver idles for over 5 seconds, it will turn to sleep mode to save the energy and increase the standby time. The power will be cut off when idle time exceeds 24 seconds, press the trigger to restore power.



Torque Fixed Ring

Fixed ring design could prevent user from adjusting the torque at will.

Maintenance-free silent brushless motor

Indicating LED

built-in indicator light to indicate tightening procedure during operation.

Waist Hook

The waist hook allows the user to hang the device on the work belt and carry it easily.

Single-Hand Operation

Push to change the rotary direction easily.

Ergonomic handle design with TPE rubber grip

PCB Control

- Low battery protection
- Temperature protection
- Current protection

Battery

10.8V 3.0Ah Lithium-ion battery

EAA-TL28A
Torque Cover

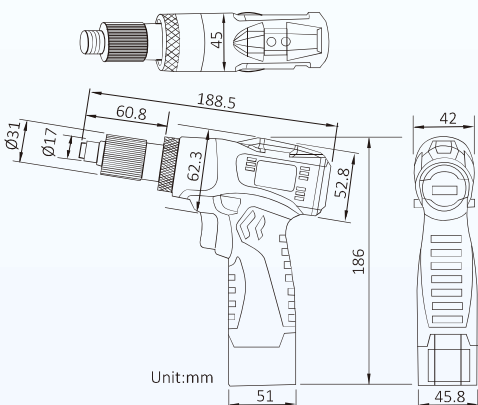

Torque Curve

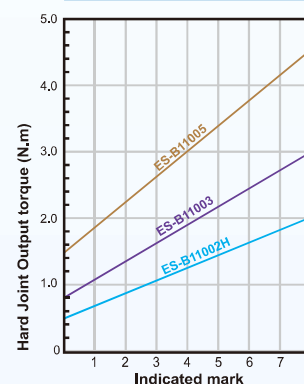

Specification:

| Model No. | Voltage (V) | Free Speed (r.p.m) | | Torque Range ($\pm 3\%$) | | | Weight (w/o Battery) | | Dimension L x H (mm) (w/o Battery) | Battery Pack | Bit Type |
|------------------|-------------|--------------------|------|-----------------------------------|--------------------------------|-----------------------------------|----------------------|-----|------------------------------------|-----------------|----------------------------|
| | | High | Low | ft-lbs (Hard Joint) Soft Joint | N.m (Hard Joint) Soft Joint | kgf/cm (Hard Joint) Soft Joint | lbs | kg | | | |
| ES-B11002HA/E-30 | 10.8 | 2700 | 1900 | 0.37 - 1.48 0.37 - 1.18 | 0.5 - 2.0 0.5 - 1.6 | 5 - 20 5 - 16 | 1.54 | 0.7 | 189 x 157 | BP1030L x 2 pcs | B Standard: HEX 6.35mm |
| ES-B11003A/E-30 | 10.8 | 1400 | 1000 | 0.59 - 2.21 0.59 - 1.77 | 0.8 - 3.0 0.8 - 2.4 | 8 - 30 8 - 24 | 1.54 | 0.7 | 189 x 157 | BP1030L x 2 pcs | E Option: HEX 5mm |
| ES-B11005A/E-30 | 10.8 | 800 | 550 | 1.11 - 3.32 1.11 - 2.66 | 1.5 - 4.5 1.5 - 3.6 | 15 - 45 15 - 36 | 1.54 | 0.7 | 189 x 157 | BP1030L x 2 pcs | F Standard: HEX 6.35mm |

*Standard tool with ESD housing & 2 batteries.

7.2V BRUSHLESS FULL AUTO SHUT-OFF CORDLESS SCREWDRIVER

NEW

Features :

- High Accuracy Assurance:** $\pm 3\%$ deviation of torque, assure the best quality.
- Ideal for limited space or areas** where cables and hoses impede handing flexibility.
- High mobility and lightweight ergonomic design,** easy to carry and operate.
- Dormancy Mode:** Once the screwdriver idles for over 5 seconds, it will turn to sleep mode to save the energy and increase the standby time. The power will be cut off when idle time exceeds 24 seconds, press the trigger to restore power.



Waist Hook

It is convenient for the production lines efficiently to have spring balancers to work together with the tools to be more.

PCB Control

1. Low Battery Protection
2. Temperature Protection
3. Current Protection

Torque Adjustment Ring

Turn torque adjust ring counter clockwise to increase torque output.

7.2V 3.0Ah Lithium-ion Battery

Forward / Reverse

Brushless Motor

Indicating LED

(OK/NG/Power/Hi&Lo)
built-in indicating light to indicate fasten procedure during operation.

Ergonomic design

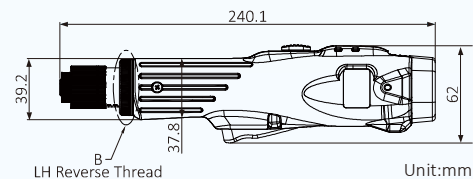
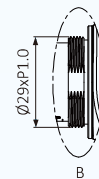
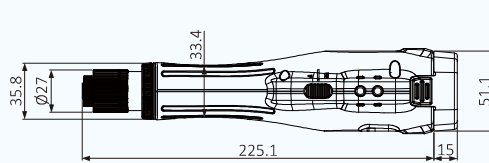

Specification:

| Model No. | Voltage (V) | Free Speed (r.p.m) | | Torque Range($\pm 3\%$) | | | Weight (w/o Battery) | | Dimension L x W (mm) (w/o Battery) | Battery Pack | Bit Type |
|--------------------|-------------|--------------------|-----|-----------------------------------|--------------------------------|-----------------------------------|----------------------|------|------------------------------------|--------------------|----------|
| | | High | Low | ft-lbs (Hard Joint) Soft Joint | N.m (Hard Joint) Soft Joint | kgf/cm (Hard Joint) Soft Joint | lbs | kg | | | |
| ES-BS0705A/E-30 | 7.2V | 1000 | 700 | 0.07 - 0.37 0.07 - 0.3 | 0.1 - 0.5 0.1 - 0.4 | 1 - 5 1 - 4 | 1.17 | 0.53 | 225 x 62 | BP0730L x 2 pcs | |
| ES-BS0712A/E-30 | 7.2V | 1000 | 700 | 0.15 - 0.89 0.15 - 0.71 | 0.2 - 1.2 0.2 - 0.96 | 2 - 12.2 2 - 9.8 | 1.17 | 0.53 | 225 x 62 | BP0730L x 2 pcs | |
| ES-BS0712LS1A/E-30 | 7.2V | 500 | 350 | 0.15 - 0.89 0.15 - 0.71 | 0.2 - 1.2 0.2 - 0.96 | 2 - 12.2 2 - 9.8 | 1.17 | 0.53 | 225 x 62 | BP0730L x 2 pcs | |

*Standard tool with ESD housing & 2 batteries.

10.8V BRUSHLESS FULL AUTO SHUT-OFF CORDLESS SCREWDRIVER

Features :

- High Accuracy Assurance:** 3% deviation of torque (Shut off type), assure the best quality.
- Economy:** Wide-ranging torque with longer life cycle of motor (2 years Motor guarantee for shut off type).
- Dormancy Mode (Power saving):** Once the screwdriver idles for over 3 second, it will turn to dormancy mode to save the energy and increase the standby time.



Indicating LED

The cordless battery has built-in indicating light to indicate the fasten procedure during operation

Brushless Motor

Innovative Brushless motor design eliminated carbon dust pollution; result in low maintenance

External Torque Adjustment

Adjust torque rapidly from external torque ring

Forward / Reverse Adjustment (Lever start type)

High & Low Speed Adjustment For extended use application

Ergonomic Design



EAA-AH1S(Option)
90° Angle Head

EAA-TL28A
Torque cover

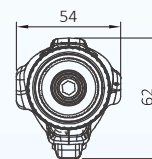
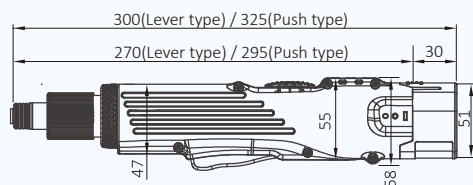
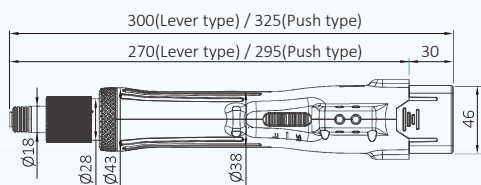

Unit:mm

Specification:

| Model No. | Voltage (V) | Free Speed (r.p.m) | | Torque Range(±3%) (Hard Joint / Soft Joint) | | | Weight (w/Battery) | | Dimension (mm) w/o Battery | Battery Pack | Bit Type |
|---------------------------|-------------|--------------------|-----|---|------------------------|----------------------------|--------------------|------|----------------------------|---|--|
| | | High | Low | ft-lbs | N.m | kgf/cm | kg | lbs | | | |
| Lever Start Type | | | | | | | | | | | |
| ES-BS1002A-30 | 10.8 | 1200 | 850 | 0.22 - 1.48 0.22 - 1.2 | 0.3 - 2.0 0.3 - 1.6 | 3.1 - 20 3.1 - 16.3 | 0.7 | 1.54 | 270 x 62 | BP1030L x 2 pcs | Standard: B HEX 6.35mm r _{9.5} 6.35 |
| ES-BS1003A-30 | 10.8 | 1200 | 850 | 0.59 - 2.21 0.59 - 1.8 | 0.8 - 3.0 0.8 - 2.4 | 8.2 - 31 8.2 - 24.5 | 0.7 | 1.54 | 270 x 62 | | Option: E HEX 5mm r ₁₆ 5 |
| ES-BS1004A-30 | 10.8 | 700 | 500 | 1.11 - 3.33 1.11 - 2.7 | 1.5 - 4.5 1.5 - 3.6 | 15.3 - 46 15.3 - 36.7 | 0.7 | 1.54 | 270 x 62 | | F HEX 6.35mm r ₁₆ 6.35 |
| Push To Start Type | | | | | | | | | | | |
| NEW ES-BS1002PA-30 | 10.8 | 1200 | - | 0.4 - 1.48 0.4 - 1.2 | 0.5 - 2.0 0.5 - 1.6 | 5.1 - 20 5.1 - 16.3 | 0.72 | 1.59 | 295 x 62 | B HEX 6.35mm r _{9.5} 6.35 | |
| NEW ES-BS1003PA-30 | 10.8 | 1200 | - | 0.7 - 2.2 0.7 - 1.8 | 1.0 - 3.0 1.0 - 2.4 | 10.2 - 30.6 10.2 - 24.5 | 0.72 | 1.59 | 295 x 62 | | |
| NEW ES-BS1004PA-30 | 10.8 | 700 | - | 1.5 - 3.32 1.5 - 2.7 | 2.0 - 4.5 2.0 - 3.6 | 20.4 - 46 20.4 - 36.7 | 0.72 | 1.59 | 295 x 62 | | |

*Standard tool with 2 batteries.

*Optional: ESD housing available.

18V BRUSHLESS FULL AUTO SHUT-OFF CORDLESS ANGLE SCREWDRIVER & WRENCH





18V BRUSHLESS FULL AUTO SHUT-OFF CORDLESS ANGLE SCREWDRIVER & WRENCH

Protection & safety:

- 1 Over electric current protection.
- 2 Slow rotation protection.
- 3 Reverse control protection.
- 4 Battery Self-identified & Sleep mode (Energy saved).

- 5 Low power protection.
- 6 Thermal protection.
- 7 Stall protection.



Charger

- Identification Of Original Battery Device: identify whether the battery is original or not, if not, the battery can not be charged. (BC21L03)



BC21L02
Weight : 0.53kg
BC21L03
Weight : 0.55kg
21 Voltage Charger



BC21L04
21 Voltage Charger
Weight : 0.53kg

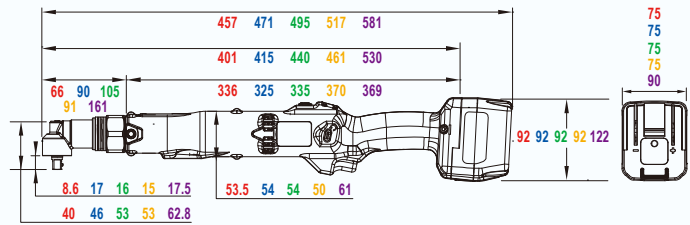

■ Body I ■ Body II ■ Body III ■ Body IV ■ Body V

Unit: mm

Specification:

| Model No. | Voltage (V) | Free Speed (r.p.m) High Low | Torque Range (Accuracy±5%) | | | Weight (w/o Battery) | | Dimension (WxLxH) (mm) | Battery Pack | Option Charger | Bit Type | |
|-----------------|-------------|-----------------------------------|--------------------------------------|----------------------------------|--------------------------------------|----------------------|------|------------------------|--------------|----------------------|---------------------------|-----------------------|
| | | | in-lbs (Hard Joint Soft Joint) | Nm (Hard Joint Soft Joint) | Kgf/cm (Hard Joint Soft Joint) | lbs | kg | | | | Standard | Option |
| Body I | | | | | | | | | | | | |
| EAS-B1805H-20 | 18 | 1,200 800 | 17.7~44.3 17.7~35.4 | 2~5 2~4 | 20~50 20~40 | 2.76 | 1.25 | 75x457x92 | BP1820L | BC21L04 | B: HEX 6,35mm 9.5 6.35 | E: HEX 5mm 16 11.5 |
| EAS-B1807-20 | 18 | 850 550 | 22.1~62.0 22.1~49.6 | 2.5~7 2.5~5.6 | 25~70 25~56 | 2.76 | 1.25 | 75x457x92 | BP1820L | | | |
| Body II | | | | | | | | | | | | |
| EAS-B1812-20 | 18 | 550 350 | 53.1~106.2 53.1~85 | 6~12 6~9.6 | 60~120 60~96 | 3.31 | 1.5 | 75x471x92 | BP1820L | BC21L04 | B: HEX 6,35mm 9.5 6.35 | W: Square Drive 3/8" |
| Body III | | | | | | | | | | | | |
| EAS-B1815-20 | 18 | 350 220 | 70.8~132.8 70.8~106.2 | 8~15 8~12 | 80~150 80~120 | 4.08 | 1.85 | 75x495x92 | BP1820L | | | |
| Body IV | | | | | | | | | | | | |
| EAS-B1808H-20 | 18 | 1200 800 | 26.6~70.8 26.6~56.6 | 3~8 3~6.4 | 30~80 30~64 | 4.19 | 1.9 | 75x517x92 | BP1822L | BC21L04 | B: HEX 6,35mm 9.5 6.35 | W: Square Drive 3/8" |
| EAS-B1815H-20 | 18 | 800 550 | 70.8~132.8 70.8~106.2 | 8~15 8~12 | 80~150 80~120 | 4.19 | 1.9 | 75x517x92 | BP1822L | | | |
| EAW-B1830-20 | 18 | 420 270 | 106.2~265.5 106.2~212.4 | 12~30 12~24 | 120~300 120~240 | 4.19 | 1.9 | 75x517x92 | BP1822L | W: Square Drive 3/8" | - | |
| Body V | | | | | | | | | | | | |
| EAW-B1845-40 | 18 | 200 130 | 132.8~398.3 132.8~318.6 | 15~45 15~36 | 150~450 150~360 | 6.27 | 2.85 | 90x581x122 | BP1841L | BC21L02 | W: Square Drive 1/2" | - |
| EAW-B1860-40 | 18 | 200 130 | 221.3~531 221.3~424.8 | 25~60 25~48 | 250~600 250~480 | 6.27 | 2.85 | 90x581x122 | BP1841L | BC21L03 | W: Square Drive 1/2" | - |

*Free load speed will be fixed when battery volume is more than 17V (17~21V).

18V BRUSHLESS FULL AUTO SHUT-OFF CORDLESS SCREWDRIVER

Features :

- High Accuracy Assurance:** 3% deviation of torque (Shut off type), assure the best quality.
- Economy:** Wide-ranging torque with longer life cycle of motor (2 years Motor guarantee for shut off type).
- Less Counterforce:** Special mechanical structure and motor improve the safety of operator and reduce occupational disease.
- Energy Saving:** With efficiency motor provide 8000 screws on loading 6Nm torque – ES-B1806-20 with fully charged battery.
- Dormancy Mode (Power saving):** Once the screwdriver is idle for over 3 seconds, it will enter sleep mode to save energy and increase standby time.



Torque Fixed Ring
Fixed ring design could prevent user from adjust the torque at will.
*For Small body I model no. EAA-TC16A
*For Small body II model no. EAA-TC17A

High & Low Speed Adjustment
For extended use application

External Torque Adjustment
Adjust torque rapidly from external torque ring

OK/NG Indication
The LED Green flash – one short buzz means “OK - Shut Off “
The LED Red flash – one Long buzz means “NG”

Low Cell Warning
20%: Flash Red Light - Pls change battery;
10%: Red light - Power cut off

Friendly Design
LED light for working in dark area

Single-Hand Operation
Push to change the rotary direction easily.
Adjust forward/reverse lever to the center position to trigger, prevent tool from misapplied.

PCB Control
• MOS Temperature Protection
• Anti-rotating Protection

Brushless Motor
Innovative Brushless motor design eliminated carbon dust pollution; result in low maintenance

Waist Hook

Dimensions:
Small Body I: 233x217x41.43 mm
Small Body II: 252.15x254.2x41.3 mm
Unit: mm

★ **With efficient motor increase the productivity.**
The performance of ES-B1806-20 with full charged battery can reach to 8,000 screws on loading 6Nm torque.

Specification:

| Model No. | Voltage (V) | Free Speed (r.p.m) | | Torque Range (±3%) | | | Weight (w/Battery) | | Dimension (WxLxH) (mm) | Battery Pack | Bit Type |
|----------------------|-------------|--------------------|-------|----------------------------------|------------------------------|----------------------------------|--------------------|------|------------------------|--------------|---|
| | | High | Low | ft-lbs (Hard Joint / Soft Joint) | Nm (Hard Joint / Soft Joint) | Kgf/cm (Hard Joint / Soft Joint) | kg | lbs | | | |
| Small Body I | | | | | | | | | | | |
| ES-B1803-20 | 18 | 1,000 | 650 | 0.74-2.59 0.74-2.10 | 1.0-3.5 1.0-2.8 | 10-35 10-28.6 | 1.34 | 2.93 | 75x217x252 | BP1820L | HEX 6.35mm 9.5 6.35 |
| ES-B1803H-20 | | 2,000 | 1,300 | 0.74-2.59 0.74-2.10 | 1.0-3.5 1.0-2.8 | 10-35 10-28.6 | 1.34 | 2.93 | 75x217x252 | | |
| ES-B1806-20 | | 1,000 | 650 | 1.48-4.44 1.48-3.60 | 2.0-6.0 2.0-4.8 | 20-60 20-48.9 | 1.34 | 2.93 | 75x217x252 | | |
| Small Body II | | | | | | | | | | | |
| ES-B1805H-20 | 18 | 2,200 | 1,400 | 1.48-3.69 1.48-3.0 | 2.0-5.0 2.0-4.0 | 20-50 20-40.8 | 1.48 | 3.25 | 75x233x254 | BP1820L | Standard: HEX 6.35mm 9.5 6.35 Option: W Square Drive 3/8" |
| ES-B1809-20 | | 1,000 | 650 | 2.22-6.66 2.22-5.3 | 3.0-9.0 3.0-7.2 | 30-90 30-73.4 | 1.48 | 3.25 | 75x233x254 | | |
| ES-B1812-20 | | 880 | 570 | 4.44-8.88 4.44-7.10 | 6.0-12.0 6.0-9.6 | 60-120 60-97.9 | 1.48 | 3.25 | 75x233x254 | | |

Model No. with "A" includes 2 batteries. e.g. ES-B1803A-20

18V BRUSHLESS FULL AUTO SHUT-OFF & SEMI-AUTO CORDLESS SCREWDRIVER



Torque Rings

SUMAKE Color Rings give you an easily visible torque marking system at a glance. Choose the color for each torque level used on your assembly line

Auto Shut-off

ES-B1808L-20
ES-B1812L-20
2.0Ah Li-ion battery

Wrench
Internal Torque Adjustment

ES-B1808L-40
ES-B1812L-40
ES-B1815L-40
ES-B1822L-40
4.0Ah Li-ion battery
(Long-Lasting Type)

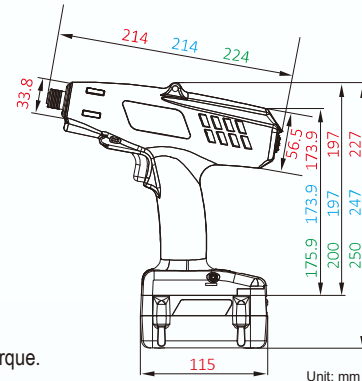

★ With efficient motor increase the productivity.
The performance of ES-B1822L-40 with full charged battery can reach to 6,000 screws on loading 22Nm torque.



External Torque Adjustment
Adjust The Torque Rapidly

Semi-Auto

ESS-B1805-20
ESS-B1808-20
ESS-B1812-20
2.0Ah Li-ion battery

ESS-B1805-40
ESS-B1808-40
ESS-B1812-40
4.0Ah Li-ion battery
(Long-Lasting Type)

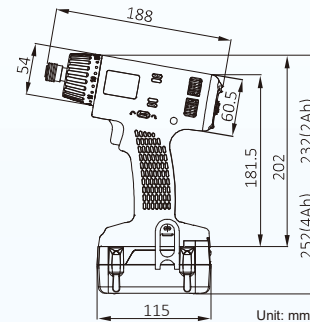

Specification:

| Model No. | Voltage (V) | Free Speed (r.p.m) | | | Torque Range (±10%) | | | Weight (w/Battery) | | Dimension (WxLxH) (mm) | Battery Pack | Bit Type |
|--------------------------------|-------------|--------------------|-------|-------|----------------------------------|------------------------------|----------------------------------|--------------------|------|------------------------|--------------|-------------------------------------|
| | | High | Mid | Low | ft-lbs (Hard Joint / Soft Joint) | Nm (Hard Joint / Soft Joint) | Kgf/cm (Hard Joint / Soft Joint) | lbs | kg | | | |
| Full Auto Shut-Off Type | | | | | | | | | | | | |
| ES-B1808L-20 | 18 | 1,200 | - | 780 | 2.96-5.92 | 4-8 | 40-80 | 2.97 | 1.35 | 90x214x227 | BP1821L | Standard: HEX 6.35mm 9.5 6.35 |
| ES-B1808L-40 | | | | | 2.96-4.70 | 4-6.4 | 40-65.3 | 3.5 | 1.6 | 90x214x247 | BP1841L | |
| ES-B1812L-20 | 18 | 720 | - | 450 | 3.7~8.88 | 5-12 | 50-120 | 2.97 | 1.35 | 90x214x227 | BP1821L | |
| ES-B1812L-40 | | | | | 3.7~7.1 | 5-9.6 | 50-97.9 | 3.5 | 1.6 | 90x214x247 | BP1841L | |
| ES-B1815L-40 | 18 | 600 | - | 380 | 4.4-11.0 4.4-8.9 | 6-15 6-12 | 60-150 60-122.4 | 3.6 | 1.65 | 90x224x250 | BP1841L | |
| ES-B1822L-40 | 18 | 350 | - | 200 | 5.92-16.16 5.92-13 | 8-22 8-17.6 | 80-220 80-179.5 | 4.2 | 1.9 | 90x224x250 | BP1841L | |
| Semi-Auto Type | | | | | | | | | | | | |
| ESS-B1805-20 | 18 | 2,200 | 1,600 | 1,100 | 1.09-3.7 | 1.5-5 | 15-50 | 2.97 | 1.35 | 90x188x232 | BP1821L | Option: Square Drive 3/8" |
| ESS-B1805-40 | | | | | 1.09-3.0 | 1.5-4 | 15-40.8 | 3.5 | 1.6 | 90x188x252 | BP1841L | |
| ESS-B1808-20 | 18 | 1,200 | 900 | 600 | 2.96-5.92 | 4-8 | 40-80 | 2.97 | 1.35 | 90x188x232 | BP1821L | |
| ESS-B1808-40 | | | | | 2.96-4.70 | 4-6.4 | 40-65.3 | 3.5 | 1.6 | 90x188x252 | BP1841L | |
| ESS-B1812-20 | 18 | 700 | 500 | 350 | 4.44-8.88 | 6-12 | 60-120 | 2.97 | 1.35 | 90x188x232 | BP1821L | |
| ESS-B1812-40 | | | | | 4.44-7.10 | 6-9.6 | 60-97.9 | 3.5 | 1.6 | 90x188x252 | BP1841L | |

Model No. with "A" includes 2 batteries. e.g. ES-B1808LA-20

BRUSHLESS CORDLESS MECHANICAL PULSE SCREWDRIVER (Remote Control Type)

Applications

Ideal tool for precise torque and assembling process management in production line.



Precise-machined mechanical pulse mechanism.

Durable brushless motor



OK in green light

NG in red light

OKALL
(program/job complete)
in orange light

OK/NG Indicator for error warning:

Capable to detect the NG situation such as wrong screw size, screw stripped and screw breaks.



Built-in LED light

Ergonomic handle design with soft rubber grip



Programed data display panel

Built-in control processing unit



Tool's program only can be set by remote controller

After 3 min stand by, tool will be switched off automatically.

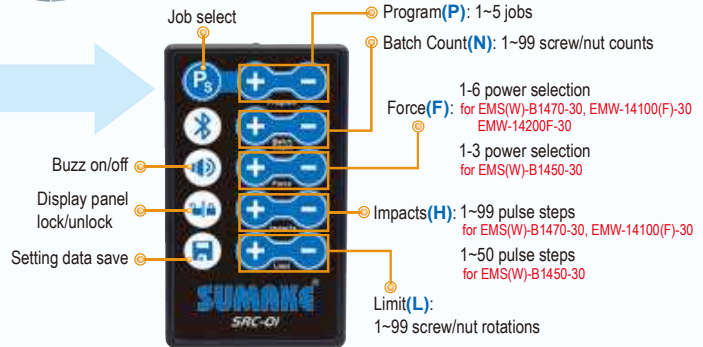

SRC-01 Remote controller

Remote controller function layout for program/torque setting:

5 unique job model setting with the combination of 6 power output selection multiplied by 99 pulse steps.



TM-M400
Torque Tester, 0-400Nm

TM-M200
Torque Tester, 0-200Nm



TM-M50
Torque Tester, 0-50Nm

Specification:

| Model No. | Bit Type | Voltage (V) | Free Speed (r.p.m) | Blow Per Minute (b.p.m) | Torque Range | | | Bolt Capacity | Overall Length (LxH) (w/o Battery) | | Net Weight (w/ Battery) | | Battery Pack | Battery Charger |
|---------------------------|-------------|-------------|--------------------|-------------------------|--------------|--------|----------|--|------------------------------------|-------------|-------------------------|------|--------------|-----------------|
| | | | | | lbf-in | Nm | Kgf/cm | | mm | in | kgs | lbs | | |
| NEW EMS-B1450-30 | Hex 6.35 mm | 14.4 | 1,900 | 2,500 | 70.9-443 | 8-50 | 82-510 | M6 (8.8~12.9) M8 (4.6~12.9) M10 (4.6~5.8) | 175 x 196 | 6.89 x 7.72 | 1.31 | 2.89 | BP1430L | BC16L01 |
| NEW EMW-B1450-30 | 3/8" Square | | | | | | | | | | | | | |
| EMS-B1470-30 | Hex 6.35 mm | 14.4 | 2,600 | 3,400 | 177-620 | 20-70 | 204-714 | M8 (8.8~12.9) M10 (4.8~8.8) M12 (4.6~5.8) | 175 x 196 | 6.89 x 7.72 | 1.33 | 2.93 | BP1430L | BC16L01 |
| EMW-B1470-30 | 3/8" Square | | | | | | | | | | | | | |
| EMW-B14100-30 | 3/8" Square | 14.4 | 2,000 | 2,600 | 177-885 | 20-100 | 204-1020 | M10 (4.8~12.9) M12 (6.8~8.8) M14 (4.6~4.8) | 175 x 196 | 6.89 x 7.72 | 1.35 | 2.98 | BP1430L | BC16L01 |
| EMW-B14100F-30 | 1/2" Square | | | | | | | | | | | | | |
| NEW EMW-B14200F-30 | 1/2" Square | 14.4 | 1,700 | 2,100 | 221.3-1770 | 25-200 | 255-2040 | M12 (4.6~12.9) M14 (4.6~8.8) M16 (4.6~5.8) | 219 x 220 | 8.62 x 8.66 | 1.83 | 4.03 | BP1430L | BC16L01 |

| Model No. | Measuring Range | | | Accuracy | Applicable Bolt | Bolt Class | Dimension (WxDxH)(mm) | Power | Accessory | Net Weight (kg) |
|--------------------|-----------------|--------|-------|----------|-------------------------|------------|-----------------------|-------------------|-------------------------------|-----------------|
| | kgf-cm | lbf-in | N.m | | | | | | | |
| TM-M400 | 0-4079 | 0-3540 | 0-400 | ±10% | M10, M12, M14, M16, M20 | 12.9 | 223x200x150 | Input 100-240 Vac | M10, M12, M14, M16, M20 Joint | 14 |
| NEW TM-M200 | 0-2039 | 0-1770 | 0-200 | ±10% | M10, M12, M14, M16 | 12.9 | 223x200x150 | Input 100-240 Vac | M10, M12, M14, M16 Joint | 14 |
| TM-M50 | 0-509 | 0-442 | 0-50 | ±10% | M6, M8, M10 | 12.9 | 131x160x130 | Input 100-240 Vac | M6, M8, M10 Joint | 5 |



BATTERY & CHARGER (Lithium Ion)

Lithium Ion Battery

- High performance Li-ion battery.
- Built in protection device to prevent battery overcharge and over discharge.
- The latch design increases intensity and convenience.
- Over-temperature protection (discharge): 72°C



BP0730L
7.2V 3.0Ah(42.5Wh)
Weight : 0.12kg



BP1030L
10.8V 3.0Ah(42.5Wh)
Weight : 0.18kg



BP1430L
14.4V 3.0Ah (42.5Wh)
Weight : 0.33kg



**BP1820L
BP1822L**
18V 2.0Ah(36Wh)
Weight : 0.49kg



BP1821L
18V 2.0Ah(36Wh)
Weight : 0.43kg



BP1841L
(Long-Lasting type)
18V 4.0Ah(70Wh)
Weight : 0.72kg

Charger



BC08L01
8.4V



BC10L01
12.6V



BC16L01
16.8V



**BC21L02
BC21L03**
21V



BC21L04
21V

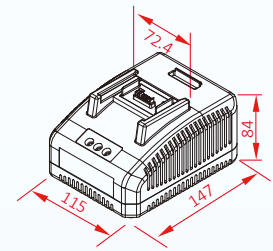
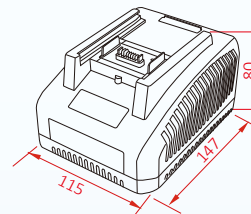
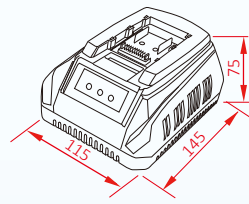
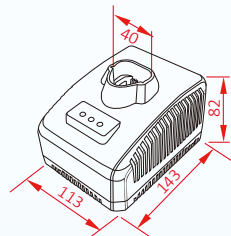
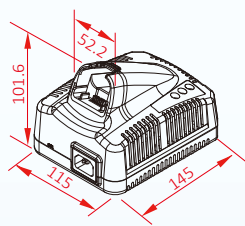

Unit: mm

| | | BC08L01 | BC10L01 / BC16L01 | BC21L02 / BC21L03 / BC21L04 |
|--|--|------------------------|------------------------|-----------------------------|
| | Power on(Identification of Original Battery) | 1 shut buzz | 1 shut buzz | 1 shut buzz |
| | Charging | x | x | x |
| | Charging > 80% | x | x | x |
| | Fully Charged | 3 long buzz | 3 long buzz | 3 long buzz |
| | Incorrect Battery Type or Battery NG | shut buzz continuously | shut buzz continuously | shut buzz continuously |

Charger Comparison Sheet

| Model No. | Input Voltage | Output Voltage | Output Current | Charging Time | LCD | Identification Of Original Battery | Warning (Buzz) | Weight (Kg) | Types Of Battery | Features |
|-----------|---------------|----------------|----------------|---|-----|------------------------------------|----------------|-------------|------------------|--|
| BC08L01 | 100-240V | 12.6V | 3A | Abt. 40mins | x | ● | ● | 0.43 | ■ | <ul style="list-style-type: none"> • SUMAKE battery chargers are compact size, light weight, quick recharge and wide voltage range 90~240V can be applicable worldwide. • Battery temperature detector and protection. • ID identification only allows the SUMAKE charger to charge to ensure battery safety and extend battery life. |
| BC10L01 | 100-240V | 12.6V | 3A | Abt. 40mins | x | ● | ● | 0.47 | ■ | |
| BC16L01 | 100-240V | 16.8V | 3A | Abt. 40mins | x | ● | ● | 0.46 | ■ | |
| BC21L02 | 100-240V | 21V | 3A | 1.95Ah: Abt. 40mins 3.9Ah: Abt. 80mins | x | x | x | 0.53 | ■ ■ | |
| BC21L03 | 100-240V | 21V | 3A | 1.95Ah: Abt. 40mins 3.9Ah: Abt. 80mins | x | ● | ● | 0.55 | ■ ■ | |
| BC21L04 | 100-240V | 21V | 3A | 2.0Ah: Abt. 40mins | x | ● | ● | 0.53 | ■ | |

★ A for UL plug / B for Europe plug / C for UK plug / D for Aus / E for India / F for China / G for Brasil / J for PSE(Japan)