

# R&S® RT-Z1M

## 1 MOHM Adapter

### Manual



1801314202  
Version 04

**ROHDE & SCHWARZ**  
Make ideas real



This manual describes the usage of the R&S RT-Z1M 1 MOhm adapter (1337.9200.02).

© 2022 Rohde & Schwarz GmbH & Co. KG  
Muehldorfstr. 15, 81671 Muenchen, Germany  
Phone: +49 89 41 29 - 0  
Email: [info@rohde-schwarz.com](mailto:info@rohde-schwarz.com)  
Internet: [www.rohde-schwarz.com](http://www.rohde-schwarz.com)

Subject to change – data without tolerance limits is not binding.

R&S® is a registered trademark of Rohde & Schwarz GmbH & Co. KG.

Trade names are trademarks of the owners.

1801.3142.02 | Version 04 | R&S®RT-Z1M

Throughout this manual, products from Rohde & Schwarz are indicated without the ® symbol, e.g. R&S®RT-Z1M is indicated as R&S RT-Z1M.

# Contents

<b>1</b>	<b>Safety information.....</b>	<b>5</b>
<b>2</b>	<b>Product description.....</b>	<b>7</b>
2.1	Key features and key characteristics.....	7
2.2	Unpacking the instrument.....	7
2.2.1	Inspecting the contents.....	8
<b>2.3</b>	<b>Description of the adapter.....</b>	<b>8</b>
2.3.1	Adapter box.....	9
2.3.2	Probe interface.....	9
2.3.3	Dimensions of adapter and probe.....	10
<b>2.4</b>	<b>Accessories.....</b>	<b>10</b>
2.4.1	Supplied accessories.....	10
2.4.2	Service accessories.....	10
<b>3</b>	<b>Putting into operation.....</b>	<b>11</b>
3.1	Connecting the adapter to the oscilloscope.....	11
3.2	Identification of adapter and probe.....	12
3.3	Connecting the adapter to the DUT.....	12
3.4	Disconnecting the adapter from the DUT.....	12
3.5	Using the adapter.....	13
3.5.1	Offset compensation.....	13
3.5.2	AC/DC switching.....	13
3.5.3	Analog bandwidth.....	14
3.5.4	Self-alignment.....	14
3.5.5	R&S ProbeMeter.....	14
<b>4</b>	<b>Typical characteristics.....</b>	<b>15</b>
4.1	Bandwidth.....	15
4.2	Step response.....	15
<b>5</b>	<b>Maintenance and service.....</b>	<b>17</b>
5.1	Cleaning.....	17
5.2	Contacting customer support.....	17
5.3	Returning for servicing.....	18

<b>5.4</b>	<b>Calibration interval.....</b>	<b>18</b>
<b>5.5</b>	<b>Storage.....</b>	<b>18</b>
<b>5.6</b>	<b>Disposal.....</b>	<b>18</b>
<b>6</b>	<b>Functional check.....</b>	<b>20</b>

# 1 Safety information

The product documentation helps you use the product safely and efficiently. Follow the instructions provided here and in the following chapters.

## Intended use

The R&S RT-Z1M 1 MOhm adapter is designed for measurements on circuits that are only indirectly connected to the mains or not connected at all. It is not rated for any measurement category.

The product is intended for the development, production and verification of electronic components and devices in industrial, administrative, and laboratory environments. Use the product only for its designated purpose. Observe the operating conditions and performance limits stated in the data sheet.

The adapter is designed for usage with oscilloscopes that have a Rohde & Schwarz probe interface. Supported Rohde & Schwarz oscilloscopes are listed in the product's data sheet.

## Where do I find safety information?

Safety information is part of the product documentation. It warns you of potential dangers and gives instructions on how to prevent personal injury or damage caused by dangerous situations.

- Printed "Safety Instructions for Oscilloscopes and Accessories" in many languages is delivered with your Rohde & Schwarz oscilloscope and probes.
- The documentation of the oscilloscope and measurement equipment provides safety instructions when you need to take care during setup or operation.

## Operating site

Only use the product indoors, and keep it dry. The product casing is not waterproof.

You can operate the product up to the altitude specified in the data sheet. The lowest specified altitude for a product of the measurement setup defines the altitude for the complete setup.

The product is suitable for pollution degree 2 environments where nonconductive contamination can occur. For more information on environmental conditions such as ambient temperature and humidity, see the data sheet.

## Electrical safety

Take the following measures for your safety:

- The adapter and the measurement instrument must be grounded. Grounding is typically ensured through the grounding of the measurement instrument to which the adapter is connected.
- Always connect the adapter to the oscilloscope first before connecting a probe to the adapter and to the circuit under test.

- Do not apply voltages higher than the maximum rated voltage, see the imprint on the adapter.
- When using the adapter in combination with a passive probe that can measure voltages higher than the maximum rated input voltage of the adapter (e.g. R&S RT-ZP10): Observe the maximum rated voltage of the probe.
- Never open the casing of the adapter. If any part of the measurement equipment is damaged or broken, stop using it.

### **Product integrity**

The R&S RT-Z1M can withstand a moderate amount of physical and electrical stress. To avoid damage, treat the adapter with care:

- Do not exceed the specified voltage limits.
- Connect the R&S RT-Z1M only to an instrument with Rohde & Schwarz probe interface. Never connect it to a usual BNC jack. Although the 7 mm coaxial connector looks like a standard BNC connector, it is constructed differently and does not fit to the standard BNC jack. The interface of the R&S RT-Z1M can withstand a higher frequency limit.
- Prevent the adapter from receiving mechanical shock.
- Do not spill liquids on the adapter.
- Store the adapter in a shock-resistant case, e.g. in the foam-lined shipping case.

## 2 Product description

### 2.1 Key features and key characteristics

The R&S RT-Z1M 1 MOhm adapter is an accessory for oscilloscopes that have only inputs with 50  $\Omega$  input impedance. It allows you to connect measurement equipment requiring a 1 M $\Omega$  load impedance to such oscilloscopes.

The R&S RT-Z1M is equipped with the Rohde & Schwarz probe interface to be connected to Rohde & Schwarz oscilloscopes that are compatible with this interface. However, oscilloscopes that already support a 1 M $\Omega$  input impedance do not support the adapter.

The Rohde & Schwarz probe interface at the adapter input allows you to connect various probes, e.g. passive probes, current probes, and active probes with Rohde & Schwarz probe interface.

The R&S RT-Z1M provides an integrated R&S ProbeMeter, which is used for probes without an own R&S ProbeMeter. Usually, these probes are passive probes.

**Table 2-1: Key features and key characteristics**

Parameter	R&S RT-Z1M
Max. Bandwidth	DC - 500 MHz
Low Pass1:	DC - 200 MHz
Low Pass2:	DC - 20 MHz
Operating voltage window	$\pm 60$ V (adapter alone)
Maximum input voltage	60 V DC 42 V AC Peak
Offset range	Up to $\pm 60$ V depending on vertical scale
Input resistance	1 M $\Omega$
Input capacitance	12 pF
AC coupling	Cutoff frequency: 7 Hz
R&S ProbeMeter, dynamic range	$\pm 60$ V
R&S ProbeMeter, measurement error	< 0.1 %
R&S probe interface	+5 V USB Power; 0.5 A current limited +12 high-power supply; 1 A current limited

### 2.2 Unpacking the instrument

The following items are included in the delivery:

- R&S RT-Z1M 1 MOhm adapter

- User manual of the R&S RT-Z1M
- R&S RT-ZP10 10:1 passive probe
- User manual of the R&S RT-ZP10
- Accessories for R&S RT-ZP10 (delivery contents is listed in the user manual of the probe)
- R&S RT-Z1M data sheet
- "Basic Safety Instructions" brochure
- Calibration certificate
- Documented calibration values (if ordered)

### 2.2.1 Inspecting the contents

1. Unpack the product carefully.
2. Retain the original packing material. Use it when transporting or shipping the product later.
3. Using the delivery notes, check the equipment for completeness.
4. Check the equipment for damage.

If the delivery is incomplete or equipment is damaged, contact Rohde & Schwarz.

A description of the supplied probe accessories is listed in the user manual of R&S RT-ZP10 passive probe.

## 2.3 Description of the adapter

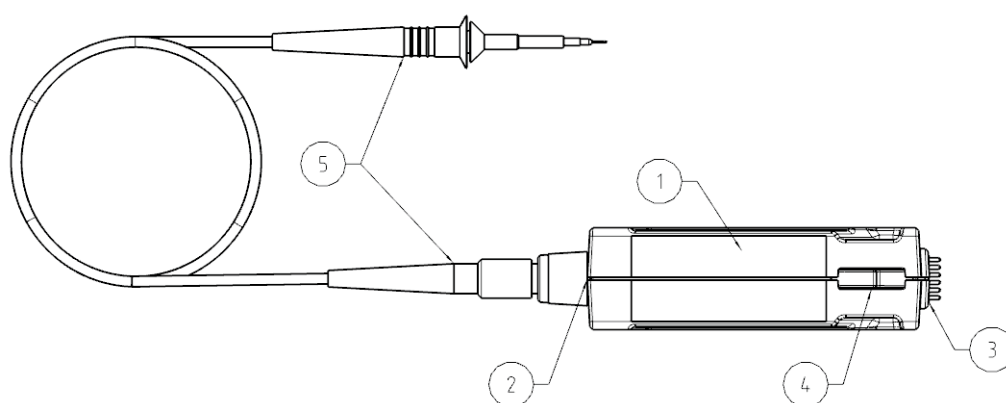

Figure 2-1: R&S RT-Z1M 1 MOhm adapter with R&S RT-ZP10 passive probe



- 1 = Adapter box
- 2 = R&S Probe interface to connect an active probe to the adapter, and a contact ring to connect a passive probe
- 3 = R&S Probe interface to connect the adapter to an oscilloscope
- 4 = Release knob
- 5 = R&S RT-ZP10 passive probe

### 2.3.1 Adapter box

The adapter box contains active circuitry to attenuate, amplify or filter the incoming signal and pass it to the 50  $\Omega$  input of the oscilloscope. There are no controls or indicators on the adapter box.

### 2.3.2 Probe interface

The R&S RT-Z1M is designed for connection to the Rohde & Schwarz probe interface of the oscilloscope. The interface provides also a USB interface and supply voltages (+5 V USB, +12 V high power). It transmits analog signals and digital data simultaneously.

The output of the R&S RT-Z1M is connected to the oscilloscope. It consists of male precision 7 mm (276 mil) coaxial connector and six pogo pins to ensure a thorough connection.

Probes are connected to the input of the R&S RT-Z1M. The Rohde & Schwarz probe interface at the input provides the power supply and USB interface to recognize and support active probes. It has also a contact ring to recognize a passive probe by its read out pin. In any case, the probe is recognized automatically by the oscilloscope.

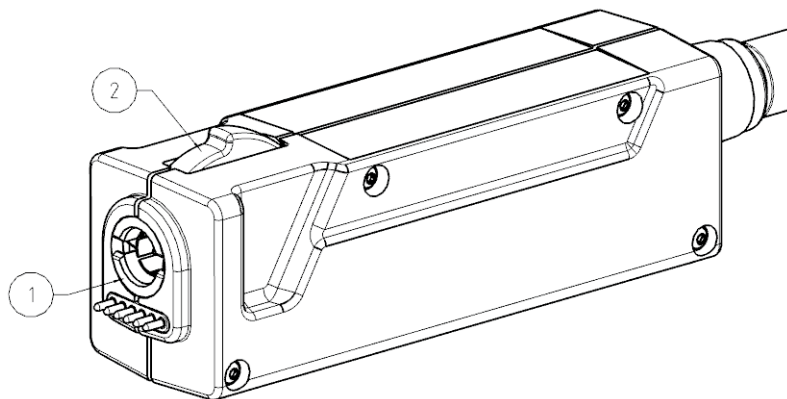

**Figure 2-2: Output interface of the adapter**

- 1 = Rohde & Schwarz probe interface with 7 mm (276 mil) coaxial connector and six pogo pins
- 2 = Release knob

### 2.3.3 Dimensions of adapter and probe

The R&S RT-Z1M 1 MOhm adapter and the R&S RT-ZP10 passive probe have the following dimensions (all values in mm):

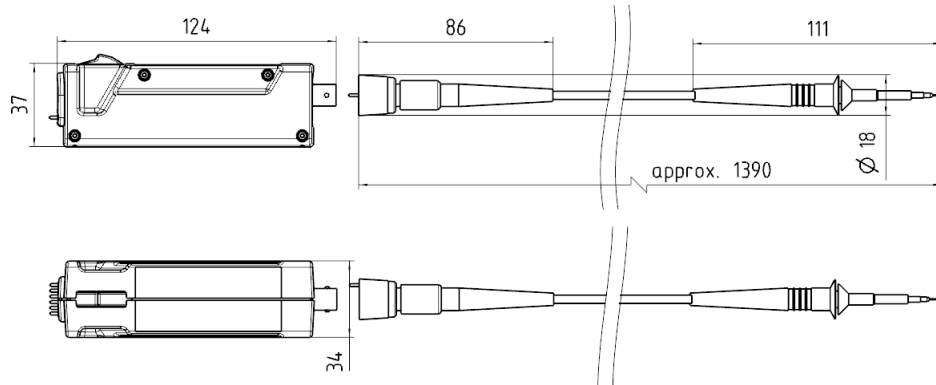

Figure 2-3: Dimensions of the R&S RT-Z1M adapter with R&S RT-ZP10

## 2.4 Accessories

### 2.4.1 Supplied accessories

Table 2-2 lists the accessories supplied with the R&S RT-Z1M 1 MOhm adapter. To order additional probes from Rohde & Schwarz, use the order number provided in the table.

Table 2-2: Supplied accessories

Item	Quantity	Description	Order number
R&S RT-ZP10 with probe accessories	1	10:1 passive Probe	1409.7550.00

### 2.4.2 Service accessories

To order accessories for servicing the probe, contact your Rohde & Schwarz service center. The following accessories are available:

Table 2-3: Service accessories

Item	Description
R&S RT-ZK1	The service kit is used to calibrate the adapter, to do performance tests, and for servicing. The service kit includes all adapters and accessories to connect the adapter to the required measuring instruments.
R&S RT-Z1M Service Manual	The service manual contains a detailed description of the performance test to verify the specifications, and other important service procedures.

## 3 Putting into operation

Read and observe the instructions in [Chapter 1, "Safety information"](#), on page 5 before using the adapter.

For your safety, follow the safety instructions delivered with your Rohde & Schwarz oscilloscope and probe, and the instructions given in the manuals of your measurement equipment.

Observe the voltage limits and ratings of the adapter and the measuring instrument. Limits and ratings are marked on the products and listed in the data sheets.

The R&S RT-Z1M works with oscilloscopes that have inputs with 50  $\Omega$  input impedance only. Oscilloscopes that support a 1 M $\Omega$  input impedance do not support the adapter.

During usage, the probe slightly heats up. Warming is normal behavior and not a sign of malfunction.

### 3.1 Connecting the adapter to the oscilloscope

1. Make sure that the oscilloscope is properly grounded.
2. **NOTICE!** Risk of damaging the probe.  
Connect the probe only to an instrument with Rohde & Schwarz probe interface. Never connect it to a usual BNC jack, because this can damage the probe interface.

Connect the adapter (1) to the Rohde & Schwarz probe interface of the oscilloscope (2).

The adapter snaps in when connected properly to the port.

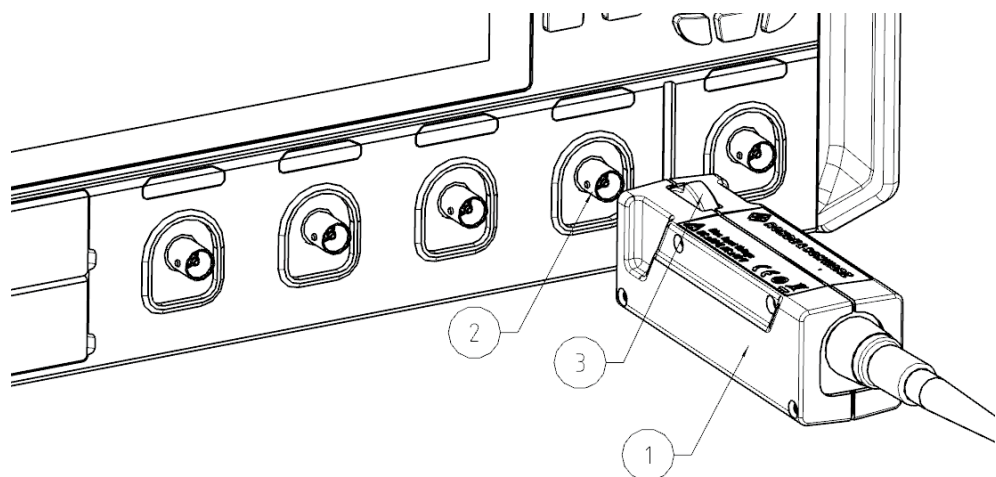

Figure 3-1: Connecting the R&S RT-Z1M to the Rohde & Schwarz oscilloscope

- ▶ To disconnect the adapter:
  - a) Press and hold the release button (3).
  - b) Pull the adapter away from the oscilloscope.

## 3.2 Identification of adapter and probe

When the R&S RT-Z1M is connected to the oscilloscope, the oscilloscope recognizes the adapter and reads out the specific parameters from the data memory of the adapter.

When a probe is connected to the adapter, the oscilloscope also reads the probe-specific parameters through the adapter.

For information on probe-specific settings and information, refer to the oscilloscope's user manual.

## 3.3 Connecting the adapter to the DUT

Observe the following step order when connecting the components of the measurement setup. Also read and observe the instructions in [Chapter 1, "Safety information"](#), on page 5.

1. Connect the adapter to the grounded oscilloscope.
2. Connect the probe to the adapter.
3. Switch off the test circuit.
4. Connect the probe to the DUT. Ensure a stable connection between the DUT and the probe.
5. Switch on the test circuit.

## 3.4 Disconnecting the adapter from the DUT

Observe the following step order when disconnecting the measurement setup. Also read and observe the instructions in [Chapter 1, "Safety information"](#), on page 5.

1. Switch off the test circuit.
2. Disconnect the probe from the DUT.
3. Disconnect the probe from the adapter.
4. Disconnect the adapter from the oscilloscope.

## 3.5 Using the adapter

All settings of the R&S RT-Z1M are adjusted on the oscilloscope.

These settings are:

- Offset
- Input coupling
- Lowpass filter (bandwidth)
- Self-alignment

The gain or attenuation of the adapter is automatically set by the oscilloscope depending on the vertical scale.

### 3.5.1 Offset compensation

The DC offset voltage is subtracted from the signal at the input of the R&S RT-Z1M. The offset is part of the vertical settings of the channel to which the adapter is connected. For details, refer to the user manual of the Rohde & Schwarz oscilloscope.

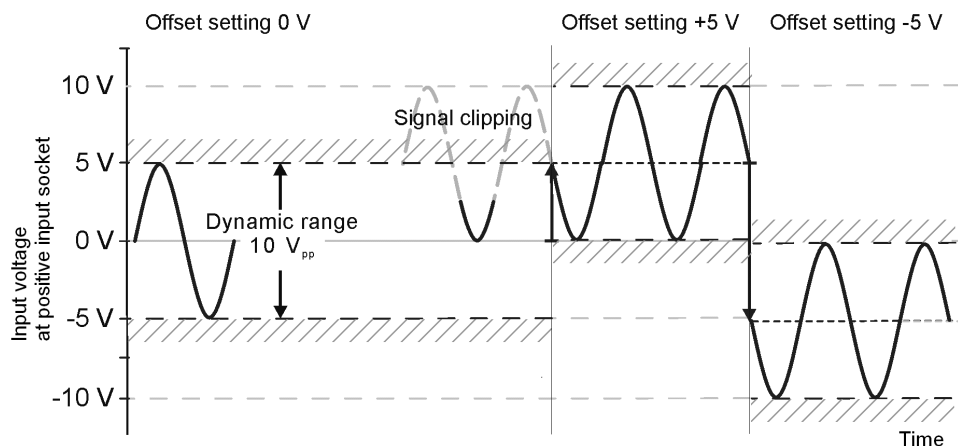

Figure 3-2: Offset of R&S RT-Z1M with R&S RT-ZP10, signal range 1V/Div

### 3.5.2 AC/DC switching

Without the adapter, the input coupling is limited to "DC" for a 50  $\Omega$  input impedance. When the R&S RT-Z1M adapter is connected to the channel input, AC coupling is also possible. Note that the R&S ProbeMeter does not show the correct DC voltage on the probe tip if AC coupling is active.

The coupling is part of the vertical settings of the channel to which the adapter is connected. For details, refer to the user manual of the Rohde & Schwarz oscilloscope.

### 3.5.3 Analog bandwidth

The R&S RT-Z1M features two lowpass filters of 200 MHz and 20 MHz. The filters reduce bandwidth and thus noise during the measurement.

The bandwidth filter is part of the vertical settings of the channel to which the adapter is connected. For details, refer to the user manual of the Rohde & Schwarz oscilloscope.

### 3.5.4 Self-alignment

The R&S RT-Z1M has a self-alignment function. Self-alignment compensates measurement errors caused by a termination impedance slightly different from 50  $\Omega$ , or an ambient temperature different from the one at which the factory alignment was done.

When the adapter is detached from the oscilloscope, the values of the self-alignment are discarded, and the original factory-alignment is reloaded. Thus, repeat the self-alignment when you reattach the probe.

The self-alignment of the adapter is part of the probe settings of the channel to which the adapter is connected. For details, refer to the user manual of the Rohde & Schwarz oscilloscope.

### 3.5.5 R&S ProbeMeter

The R&S ProbeMeter is an integrated voltmeter that measures DC voltages with higher precision compared to the oscilloscope's DC accuracy. The DC voltage is measured continuously and runs parallel to the time domain measurement of the oscilloscope.

When the R&S ProbeMeter is active, the measured values are displayed on the oscilloscope. The R&S ProbeMeter state is part of the probe settings of the channel to which the adapter is connected. For details, refer to the user manual of the Rohde & Schwarz oscilloscope.

Advantages of the R&S ProbeMeter:

- Measures DC voltages of different levels, no need to adjust the measurement range of the oscilloscope.
- True DC measurement (integration time > 100 ms), not mathematical average of displayed waveform.
- High measurement accuracy and low temperature sensitivity.
- Simple means of setting the oscilloscope's trigger level and vertical scaling if a waveform is not visible.
- Independent of oscilloscope settings for position, vertical scale, horizontal scale, and trigger.

With adapter, you can use the R&S ProbeMeter also with passive probes, which do not have an own R&S ProbeMeter. In this combination, the R&S ProbeMeter of the adapter takes effect. Note that the R&S ProbeMeter does not show the correct DC voltage on the probe tip if AC coupling is active. Active probes that have a R&S ProbeMeter use their own one as usual, the R&S ProbeMeter of the adapter is not used.

## 4 Typical characteristics

The R&S RT-Z1M 1 MOhm adapter has several gain or attenuation modes. The mode of the adapter, and thus the gain or attenuation, depends on the vertical scale and is set automatically by the oscilloscope to achieve optimized system behavior.

### 4.1 Bandwidth

The R&S RT-Z1M has a bandwidth of 500 MHz. You can reduce the bandwidth to 200 MHz or 20 MHz, see [Chapter 3.5.3, "Analog bandwidth"](#), on page 14. The transfer functions of the gain or attenuation modes are shown in [Figure 4-1](#).

The bandwidth of a system specifies the maximum frequency at which a purely sinusoidal signal is still transferred at 70 % (–3 dB) of its amplitude.

The bandwidth of the whole measurement setup also depends on the bandwidth of the probe connected to the R&S RT-Z1M, and the bandwidth of the oscilloscope.

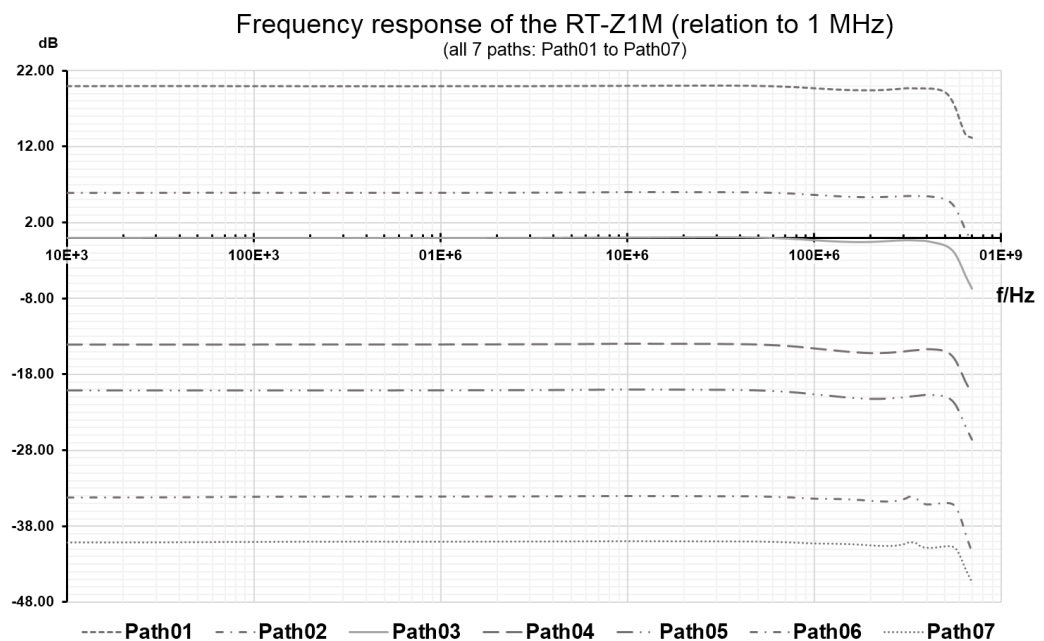

Figure 4-1: Amplitude/frequency response of the R&S RT-Z1M, all 7 modes

### 4.2 Step response

The step response up to 20 ns of the R&S RT-Z1M 1 MOhm adapter is shown in [Figure 4-2](#). The propagation delay is normalized to the beginning of the step. The amplitude is normalized to the steady state value.

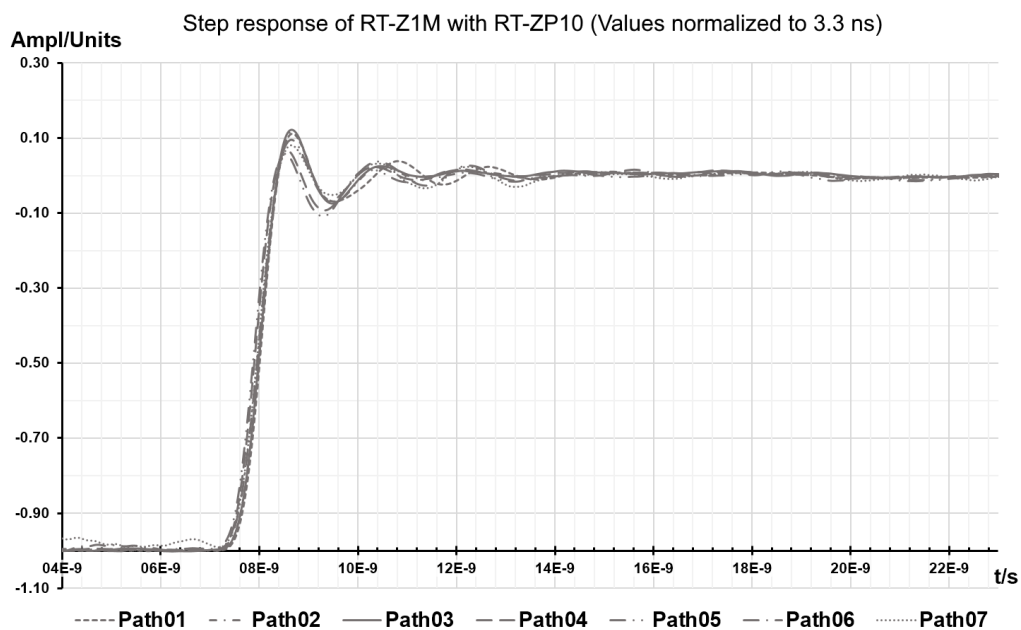

Figure 4-2: Step response of the R&S RT-Z1M (all 7 modes)

The rise time of a system is inversely proportional to the bandwidth. The following approximation applies:

$$t_{rise} \approx \frac{0.4}{BW}$$

The minimum measurable rise time of the whole setup also depends on the bandwidth of the probe connected to the R&S RT-Z1M, and the bandwidth of the oscilloscope.



## 5 Maintenance and service

Like all Rohde & Schwarz products, Rohde & Schwarz probes and adapters are of high quality and require only minimum service and repair. However, if service or calibration is needed, contact your Rohde & Schwarz service center. Return a defective product to the Rohde & Schwarz service center for diagnosis and exchange.

### 5.1 Cleaning

1. Clean the outside of the product using a soft cloth moistened with either distilled water or isopropyl alcohol. Keep in mind that the casing is not waterproof.

**Note:** Do not use cleaning agents. Solvents (thinners, acetone), acids and bases can damage the labeling or plastic parts.

2. Dry the product completely before using it.

### 5.2 Contacting customer support

#### Technical support – where and when you need it

For quick, expert help with any Rohde & Schwarz product, contact our customer support center. A team of highly qualified engineers provides support and works with you to find a solution to your query on any aspect of the operation, programming or applications of Rohde & Schwarz products.

#### Contact information

Contact our customer support center at [www.rohde-schwarz.com/support](http://www.rohde-schwarz.com/support), or follow this QR code:



Figure 5-1: QR code to the Rohde & Schwarz support page

## 5.3 Returning for servicing

Use the original packaging to return your R&S RT-Z1M to your Rohde & Schwarz service center. A list of all service centers is available on:

[www.services.rohde-schwarz.com](http://www.services.rohde-schwarz.com)

If you cannot use the original packaging, consider the following:

1. Use a sufficiently sized box.
2. Protect the product from damage and moisture (e.g. with bubble wrap).
3. Use some kind of protective material (e.g. crumpled newspaper) to stabilize the product inside the box.
4. Seal the box with tape.
5. Address the package to your nearest Rohde & Schwarz service center.

## 5.4 Calibration interval

The recommended calibration interval for R&S RT-Z1M 1 MOhm adapter is two years. For servicing, send the probe to your nearest Rohde & Schwarz service center (see [Chapter 5.3, "Returning for servicing"](#), on page 18).

## 5.5 Storage

Protect the product against dust. Ensure that the environmental conditions, e.g. temperature range and climatic load, meet the values specified in the data sheet.

Store the product in a shock-resistant case, e.g. in the shipping case.

## 5.6 Disposal

Rohde & Schwarz is committed to making careful, ecologically sound use of natural resources and minimizing the environmental footprint of our products. Help us by disposing of waste in a way that causes minimum environmental impact.

### Disposing electrical and electronic equipment

A product that is labeled as follows cannot be disposed of in normal household waste after it has come to the end of its service life. Even disposal via the municipal collection points for waste electrical and electronic equipment is not permitted.



**Figure 5-2: Labeling in line with EU directive WEEE**

Rohde & Schwarz has developed a disposal concept for the eco-friendly disposal or recycling of waste material. As a manufacturer, Rohde & Schwarz completely fulfills its obligation to take back and dispose of electrical and electronic waste. Contact your local service representative to dispose of the product.

## 6 Functional check

The functional check confirms the basic operation of the R&S RT-Z1M 1 MOhm adapter and the R&S RT-ZP10 passive probe using simple measurement equipment.

The functional check is not suitable to verify compliance with the specifications of the R&S RT-Z1M 1 MOhm adapter, because the test results are influenced by the used oscilloscope.

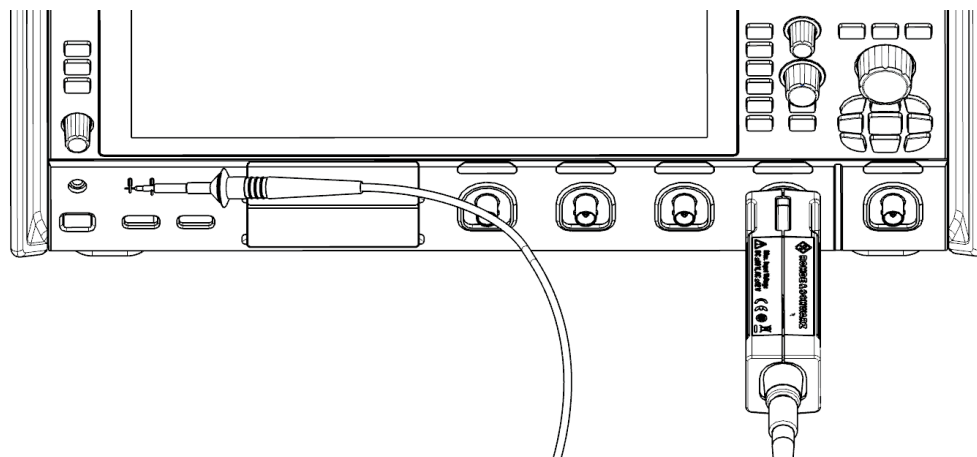

**Figure 6-1: Functional check**

1. Connect the R&S RT-Z1M to an R&S oscilloscope as described in [Chapter 3.1, "Connecting the adapter to the oscilloscope"](#), on page 11.
2. Connect the R&S RT-ZP10 probe to the probe interface of the adapter.
3. Connect the probe tip to the square wave output  $\square$  of the oscilloscope.
4. Connect the ground lead to the probe ground connector  $\perp$  of the oscilloscope.
5. Press the [Preset] and then the [Autoset] key on the oscilloscope.  
A square wave between 0 V and 1 V is displayed on the oscilloscope screen.