

# **RIGOL**

## **Service Guide**

### **DSG3000B Series RF Signal Generator**

**Aug. 2020**  
**RIGOL TECHNOLOGIES CO., LTD.**



---

# Guaranty and Declaration

## Copyright

© 2020 RIGOL TECHNOLOGIES CO., LTD. All Rights Reserved.

## Trademark Information

RIGOL® is the trademark of RIGOL TECHNOLOGIES CO., LTD.

## Publication Number

SGG03100-1110

## Notices

- RIGOL products are covered by P.R.C. and foreign patents, issued and pending.
- RIGOL reserves the right to modify or change parts of or all the specifications and pricing policies at the company's sole decision.
- Information in this publication replaces all previously released materials.
- Information in this publication is subject to change without notice.
- RIGOL shall not be liable for either incidental or consequential losses in connection with the furnishing, use, or performance of this manual, as well as any information contained.
- Any part of this document is forbidden to be copied, photocopied, or rearranged without prior written approval of RIGOL.

## Product Certification

RIGOL guarantees that this product conforms to the national and industrial standards in China as well as the ISO9001:2015 standard and the ISO14001:2015 standard. Other international standard conformance certifications are in progress.

## Contact Us

If you have any problem or requirement when using our products or this manual, please contact RIGOL.

E-mail: [service@rigol.com](mailto:service@rigol.com)

Website: [www.rigol.com](http://www.rigol.com)

# Safety Requirement

## General Safety Summary

Please review the following safety precautions carefully before putting the instrument into operation so as to avoid any personal injury or damage to the instrument and any product connected to it. To prevent potential hazards, please follow the instructions specified in this manual to use the instrument properly.

### **Use Proper Power Cord.**

Only the exclusive power cord designed for the instrument and authorized for use within the local country could be used.

### **Ground the Instrument.**

The instrument is grounded through the Protective Earth lead of the power cord. To avoid electric shock, connect the earth terminal of the power cord to the Protective Earth terminal before connecting any input or output terminals.

### **Connect the Probe Correctly.**

If a probe is used, the probe ground lead must be connected to earth ground. Do not connect the ground lead to high voltage. Improper way of connection could result in dangerous voltages being present on the connectors, controls or other surfaces of the oscilloscope and probes, which will cause potential hazards for operators.

### **Observe All Terminal Ratings.**

To avoid fire or shock hazard, observe all ratings and markers on the instrument and check your manual for more information about ratings before connecting the instrument.

### **Use Proper Overvoltage Protection.**

Ensure that no overvoltage (such as that caused by a bolt of lightning) can reach the product. Otherwise, the operator might be exposed to the danger of an electric shock.

### **Do Not Operate Without Covers.**

Do not operate the instrument with covers or panels removed.

### **Do Not Insert Objects into the Air Outlet.**

Do not insert anything into the holes of the fan to avoid damaging the instrument.

### **Use Proper Fuse.**

Please use the specified fuses.

### **Avoid Circuit or Wire Exposure.**

Do not touch exposed junctions and components when the unit is powered on.

### **Do Not Operate with Suspected Failures.**

If you suspect that any damage may occur to the instrument, have it inspected by **RIGOL** authorized personnel before further operations. Any maintenance, adjustment or replacement especially to circuits or accessories must be performed by **RIGOL** authorized personnel.

### **Provide Adequate Ventilation.**

Inadequate ventilation may cause an increase of temperature in the instrument, which would cause damage to the instrument. So please keep the instrument well ventilated and inspect the air outlet and the fan regularly.

**Do Not Operate in Wet Conditions.**

To avoid short circuit inside the instrument or electric shock, never operate the instrument in a humid environment.

**Do Not Operate in an Explosive Atmosphere.**

To avoid personal injuries or damage to the instrument, never operate the instrument in an explosive atmosphere.

**Keep Product Surfaces Clean and Dry.**

To avoid dust or moisture from affecting the performance of the instrument, keep the surfaces of the instrument clean and dry.

**Prevent Electrostatic Impact.**

Operate the instrument in an electrostatic discharge protective environment to avoid damage induced by static discharges. Always ground both the internal and external conductors of cables to release static before making connections.

**Use the Battery Properly.**

Do not expose the battery (if available) to high temperature or fire. Keep it out of the reach of children. Improper change of a battery (lithium battery) may cause an explosion. Use the **RIGOL** specified battery only.

**Handle with Caution.**

Please handle with care during transportation to avoid damage to keys, knobs, interfaces, and other parts on the panels.

## Safety Notices and Symbols

### Safety Notices in this Manual:

**WARNING**

Indicates a potentially hazardous situation or practice which, if not avoided, will result in serious injury or death.

**CAUTION**

Indicates a potentially hazardous situation or practice which, if not avoided, could result in damage to the product or loss of important data.

### Safety Terms on the Product:

**DANGER** It calls attention to an operation, if not correctly performed, could result in injury or hazard immediately.

**WARNING** It calls attention to an operation, if not correctly performed, could result in potential injury or hazard.

**CAUTION** It calls attention to an operation, if not correctly performed, could result in damage to the product or other devices connected to the product.

### Safety Symbols on the Product:



Hazardous Voltage



Safety Warning

Protective Earth  
Terminal

Chassis Ground



Test Ground

---

# Document Overview

## Format Conventions in this Manual

### 1. Key

The key on the front panel is denoted by the format of "Key Name (Bold) + Text Box" in the manual. For example, **FREQ** denotes the **FREQ** key.

### 2. Menu

The menu items are denoted by the format of "Menu Word (Bold) + Character Shading". For example, **Frequency** denotes the "Frequency" menu item under **FREQ**.

### 3. Connector

The connectors on the front or rear panel are usually denoted by the format of "Connector Name (Bold) + Square Brackets (Bold)". For example, **[RF OUTPUT 50Ω]**.

### 4. Operation Procedures

The next step of the operation is denoted by an arrow "→" in the manual. For example, **FREQ** → **Frequency** denotes pressing **FREQ** on the front panel first and then pressing **Frequency**.

## Content Conventions in this Manual

The DSG3000B series RF signal generator includes DSG3065B, DSG3065B-IQ, DSG3136B, and DSG3136B-IQ. This manual takes DSG3136B-IQ as an example to illustrate the functions and operation methods of DSG3000B series. For details, refer to *DSG3000B User Guide*.

## Manuals of this Product

Quick Guide, User Guide, Programming Guide, Data sheet, etc. For the latest version of this manual, download it from the official website of **RIGOL** ([www.rigol.com](http://www.rigol.com)).

# Contents

- Guaranty and Declaration.....I**
- Safety Requirement..... II**
  - General Safety Summary..... II
  - Safety Notices and Symbols .....IV
- Document Overview ..... V**
- Chapter 1 Disassembly and Assembly ..... 1-1**
  - Notices to Disassembly and Assembly ..... 1-1
  - Exploded View Drawing ..... 1-2
  - Disassemble the Rear Support Legs ..... 1-4
  - Disassemble the Handle..... 1-5
  - Disassemble the Brackets..... 1-6
  - Disassemble the Metal Enclosure ..... 1-7
  - Disassemble the Front Protective Covers ..... 1-8
  - Disassemble the ATT Module..... 1-9
  - Disassemble the Shield and Power Supply Board ..... 1-10
  - Disassemble the Output Signal Cable ..... 1-11
  - Disassemble the Front Panel Assembly ..... 1-12
  - Disassemble the PCIE Cables..... 1-13
  - Disassemble the Digital Module ..... 1-14
  - Disassemble the OCXO Module ..... 1-15
  - Disassemble the RF Module..... 1-16
  - Disassemble the IQ Module..... 1-17
  - Disassemble the Fan..... 1-18
  - Disassemble the Panel ..... 1-19
  - Disassemble the LCD ..... 1-20
  - Disassemble the Keypad Board ..... 1-21
  - Disassemble the Nut Connector ..... 1-22
  - Assembly Procedures..... 1-23
- Chapter 2 Troubleshooting&Maintenance ..... 2-1**
  - Basic Troubleshooting ..... 2-1
  - Maintenance..... 2-4
  - Environmental Considerations..... 2-5



# Chapter 1 Disassembly and Assembly

## Notices to Disassembly and Assembly

### Notices:

- Do not disassemble the instrument unless for working requirement.
- Only authorized personnel are allowed to disassemble the instrument.
- Cut off the power supply before disassembling the instrument.
- Please wear anti-static wrist strap or make other anti-static precaution when disassembling the instrument.
- Please use proper tools and follow the correct steps.
- Take care not to deform the metal structure or get hurt when disassembling the metal structures.

### Required Tools:

- Phillips screwdriver T20/T10
- BNC socket wrench
- SMA torque wrench



---

**WARNING**

Ensure that the power supply is cut off before disassembling the instrument. Only well-trained professional personnel or qualified personnel are allowed to disassemble the instrument.

---

# Exploded View Drawing

You need to get a basic understanding of the main parts of the instrument before disassembling and assembling the instrument. When disassembling or assembling the instrument, please follow the procedures and take care not to scratch the surfaces of the instrument. This manual mainly illustrates the disassembly and assembly methods of the DSG3000B series RF signal generator. The exploded view drawing of DSG3000B (with IQ and OCXO-A08) is shown in Figure 1-1.

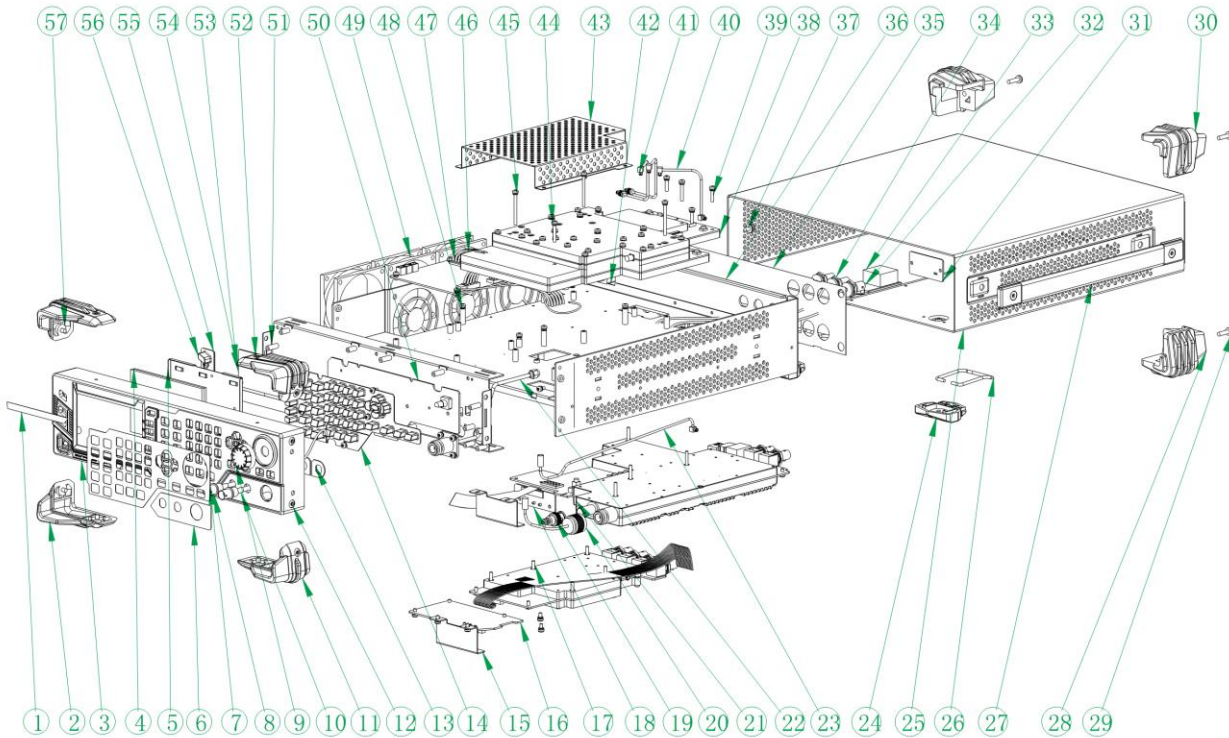

Figure 1-1 DSG3000B Exploded View Drawing

Table 1-1 Part Description of DSG3000B Exploded View Drawing

No.	Part Name	No.	Part Name
1	Front Label	30	Rear Support Leg (Top)
2	Front Protective Cover (Bottom-Left)	31	OCXO Plate
3	Panel	32	Customized Cable BNC-QMA
4	LCD	33	OCXO Module
5	LCD Shield	34	BNC Nut
6	BNC Film	35	Back Label
7	Keypad Film	36	Metal Chassis
8	Customized Cable BNC-QMA	37	M4*8 Torx Pan Head Combination Screw
9	Knob	38	ATT Module
10	Customized Cable BNC(F)-SMA(M)	39	M3*14 Torx Pan Head Combination Screw
11	Front Protective Cover (Bottom-Right)	40	Customized Cable MCX(M,90 deg)-MCX(M,90 deg)
12	M4*8 Torx Pan Head Screw	41	Customized Cable MCX(M,90 deg)-MCX(M,180 deg)
13	BNC Lock Washer	42	Power Cord Connector
14	Main Key	43	Power Supply Shield
15	PCIE Converter Board	44	M3*20 Torx Pan Head Combination Screw
16	Digital Module	45	M3*18 Torx Pan Head Combination Screw

17	IQ Module	46	DCDC Plate
18	PCIE Converter Cable	47	Power Supply Board
19	Customized BNC(M)-SMA(F) Connector	48	M3*6 Torx Pan Head Combination Screw
20	Customized N(M)-SMA(F)	49	Fan
21	RF Module	50	Main Keypad Board
22	Customized Cable N(F)-SMA(M)	51	Metal Front Panel
23	Customized Cable MCX(M,90 deg)-SMB(F,180 deg)	52	M4*8 Torx Pan Head Screw
24	Bracket	53	Front Protective Cover (Top-Right)
25	Metal Enclosure	54	Screen Converter Board
26	Mental Arm Brace	55	Keypad Board at the Left Side of Screen
27	Handle	56	Keypad at the Left Side of Screen
28	Rear Support Leg (Bottom)	57	Front Protective Cover (Top-Left)
29	M4*14 Torx Pan Head Screw	--	--

**The recommended disassembly procedures are as follows:**

Disassemble the Rear Support Legs → Disassemble the Handle → Disassemble the Brackets → Disassemble the Metal Enclosure → Disassemble the Front Protective Covers → Disassemble the ATT Module → Disassemble the Shield and Power Supply Board → Disassemble the Output Signal Cable → Disassemble the Front Panel Assembly → Disassemble the PCIE Cables → Disassemble the Digital Module → Disassemble the OCXO Module → Disassemble the RF Module → Disassemble the IQ Module → Disassemble the Fan → Disassemble the Panel → Disassemble the LCD → Disassemble the Keypad Board → Disassemble the Nut Connector

## Disassemble the Rear Support Legs

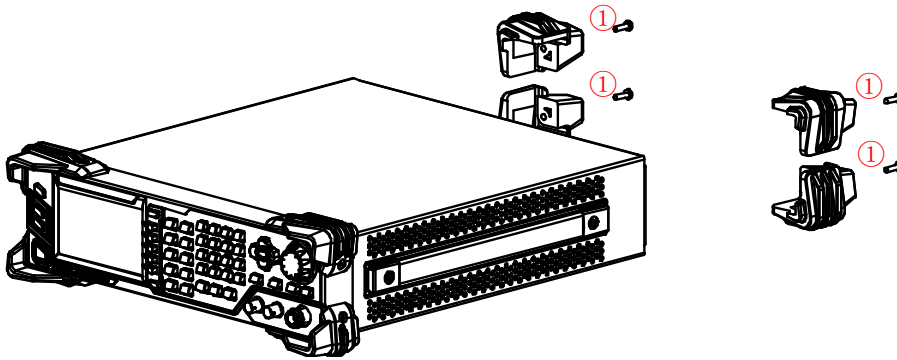

Figure 1-2 Disassemble the Rear Support Legs

### Part Description:

① 4 screws (M4\*14 torx pan head screw, used for securing the rear support legs)

### Disassembly Steps:

1. Use the T20 screwdriver to remove 4 screws (①) that secure the rear support legs.
2. Take off the rear support legs gently.

**Note:** When assembling the rear support legs, pay attention to the mounting position of support legs. The support leg with 2 ribs on it should be mounted at the top; whereas the support leg with three ribs on it should be mounted at the bottom.

## Disassemble the Handle

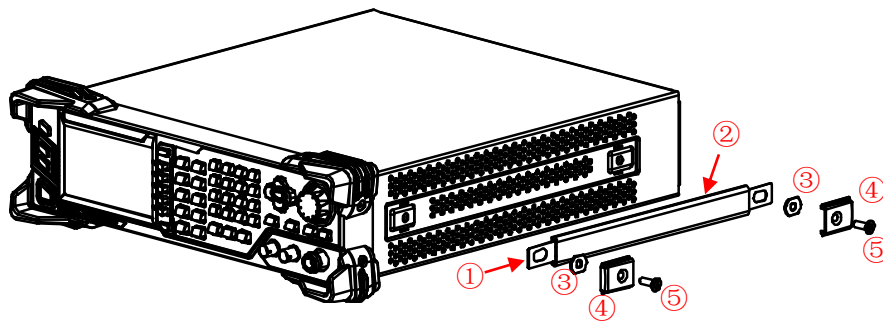

Figure 1-3 Disassemble the Handle

### Part Description:

- ① 1 metal plate
- ② 1 handle sleeve
- ③ 2 handle plate positioning rings
- ④ 2 handle positioning plastic components
- ⑤ 2 screws (M5\*14 torx flat head countersunk screw, used for fastening the handle)

### Disassembly Steps:

1. Use the T20 screwdriver to remove 2 screws (⑤) that secure the handle.
2. Remove two handle positioning plastic components, two handle plate positioning rings, and the handle (consists of the handle sleeve and the metal plate).

**Note:** When assembling, check whether the metal enclosure has been installed properly.

## Disassemble the Brackets

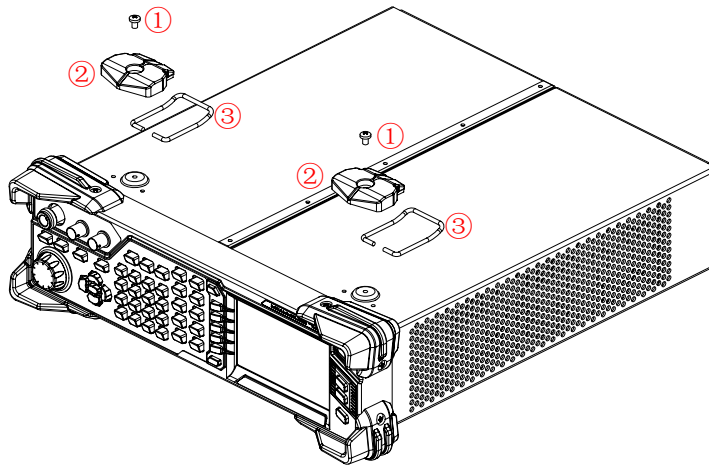

Figure 1-4 Disassemble the Brackets

### Part Description:

- ① 2 screws (M4\*6 torx pan head screw, used for securing the brackets)
- ② 2 brackets
- ③ 2 metal arm braces

### Disassembly Steps:

1. Use the T20 screwdriver to remove 2 screws (①) that secure the brackets.
2. Take off the brackets gently.

**Note:** When assembling, install the metal arm braces in the proper direction.

## Disassemble the Metal Enclosure

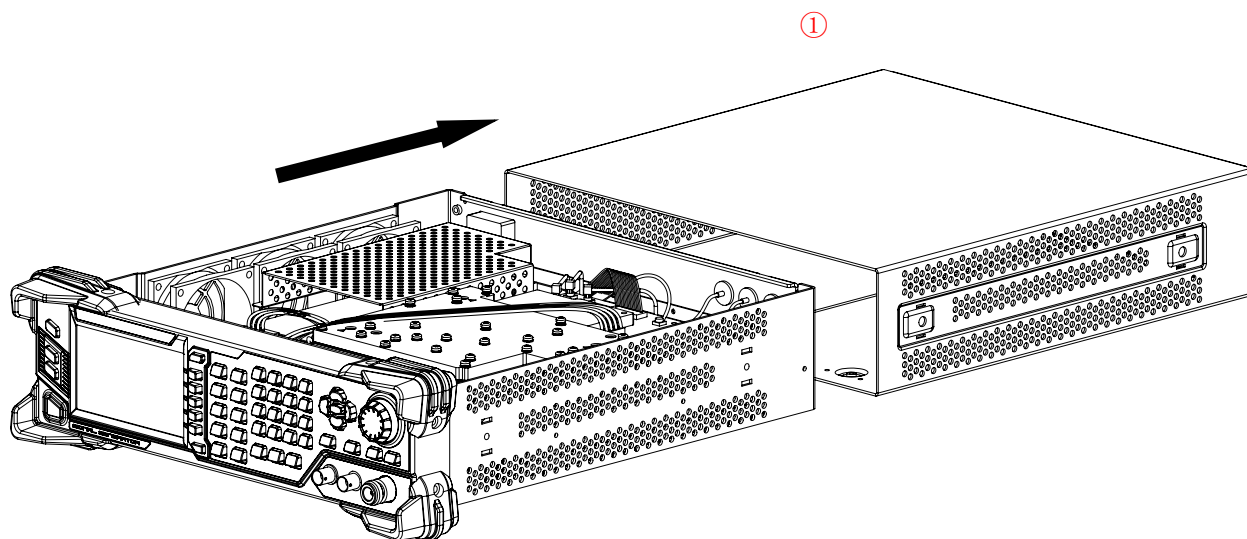

Figure 1-5 Disassemble the Metal Enclosure

### Part Description:

- ① 1 metal enclosure

### Disassembly Steps:

1. Remove the metal enclosure in the arrow direction (as shown in the figure above).

**Note:** When assembling the metal enclosure, the side of the metal enclosure with a binding seam should be placed downward.

## Disassemble the Front Protective Covers

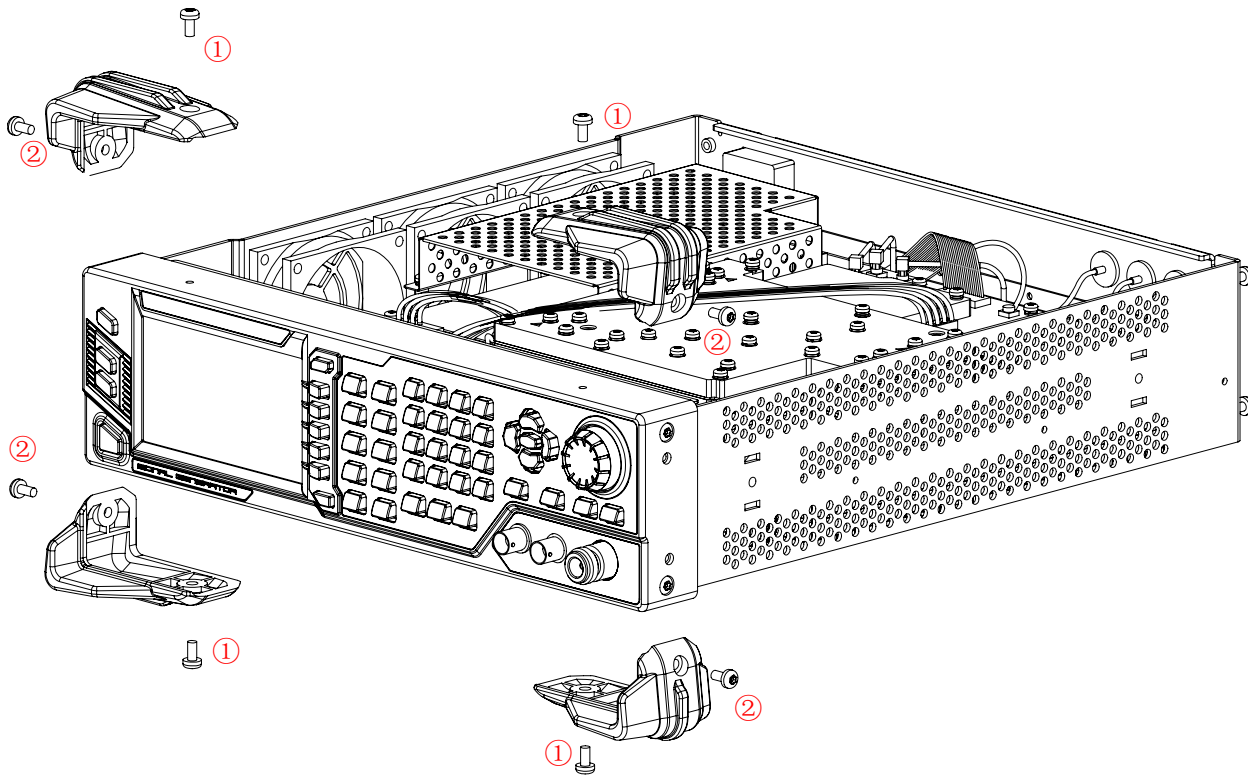

Figure 1-6 Disassemble Front Protective Covers

### Part Description:

- ① 4 screws (M4\*8 torx pan head screw, used for fastening the front protective covers)
- ② 4 screws (M4\*10 torx pan head screw, used for fastening the front protective covers)

### Disassembly Steps:

1. Use the T20 screwdriver to remove 8 screws that secure the front protective covers.
2. Remove the four front protective covers gently.

**Note:** When assembling the front protective covers, pay attention to the mounting position of front protective covers. The front protective cover with 2 ribs on it should be mounted at the top; whereas the front protective cover with one rib on it should be mounted at the bottom.



## Disassemble the ATT Module

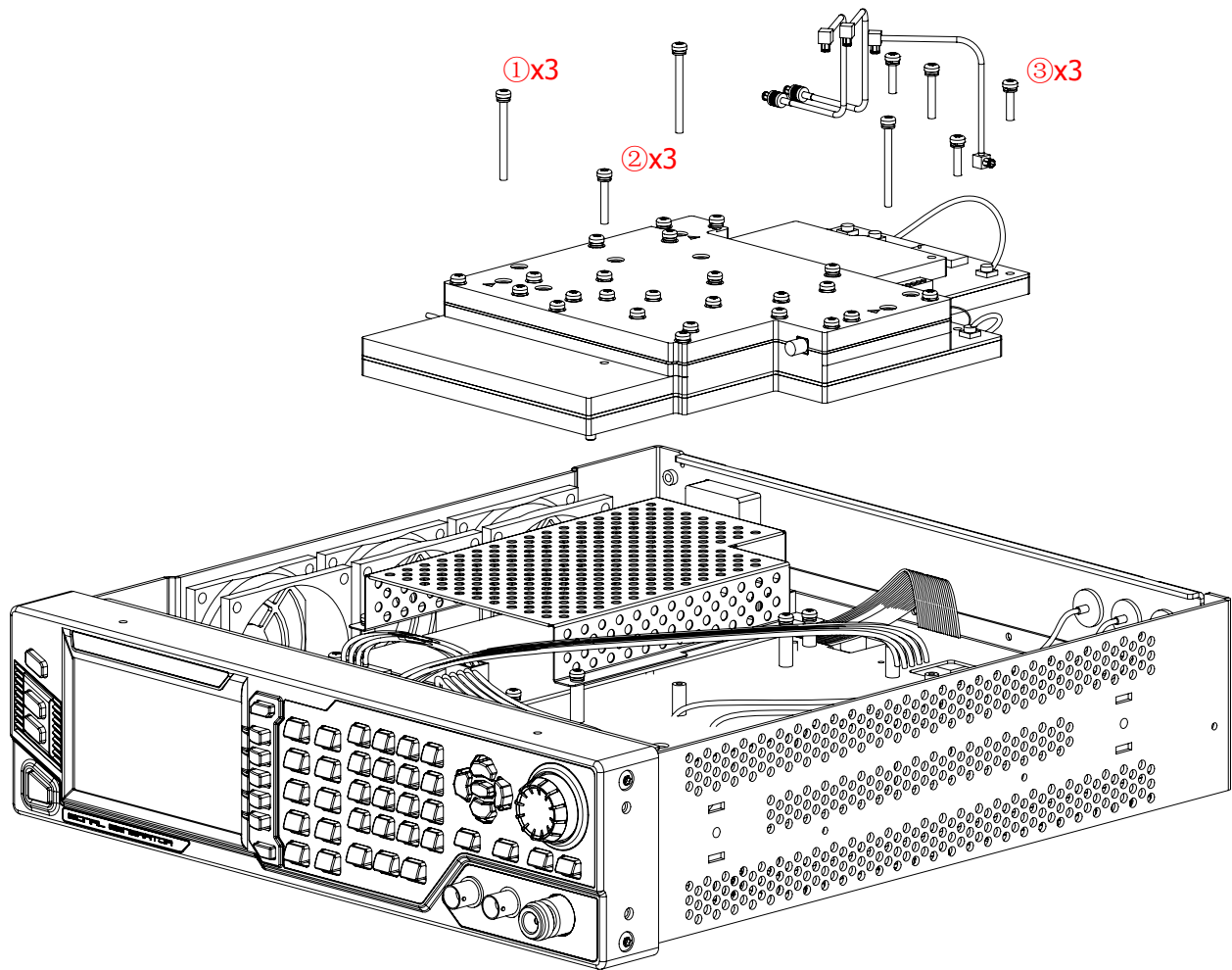

Figure 1-7 Disassemble the ATT Module

### Part Description:

- ① 3 screws (M3\*35 torx pan head combination screw, used for fastening the ATT module)
- ② 2 screws (M3\*20 torx pan head combination screw, used for fastening the ATT module)
- ③ 3 screws (M3\*14 torx pan head combination screw, used for fastening the ATT module)

### Disassembly Steps:

1. Use the T10 screwdriver to remove all the screws that secure the ATT module.
2. Remove the ATT module gently.

#### Tip:

Before disassembling the ATT module, pay attention to the connecting positions of the cables on the ATT module to avoid incorrect connection or incomplete connection when assembling the cables.

## Disassemble the Shield and Power Supply Board

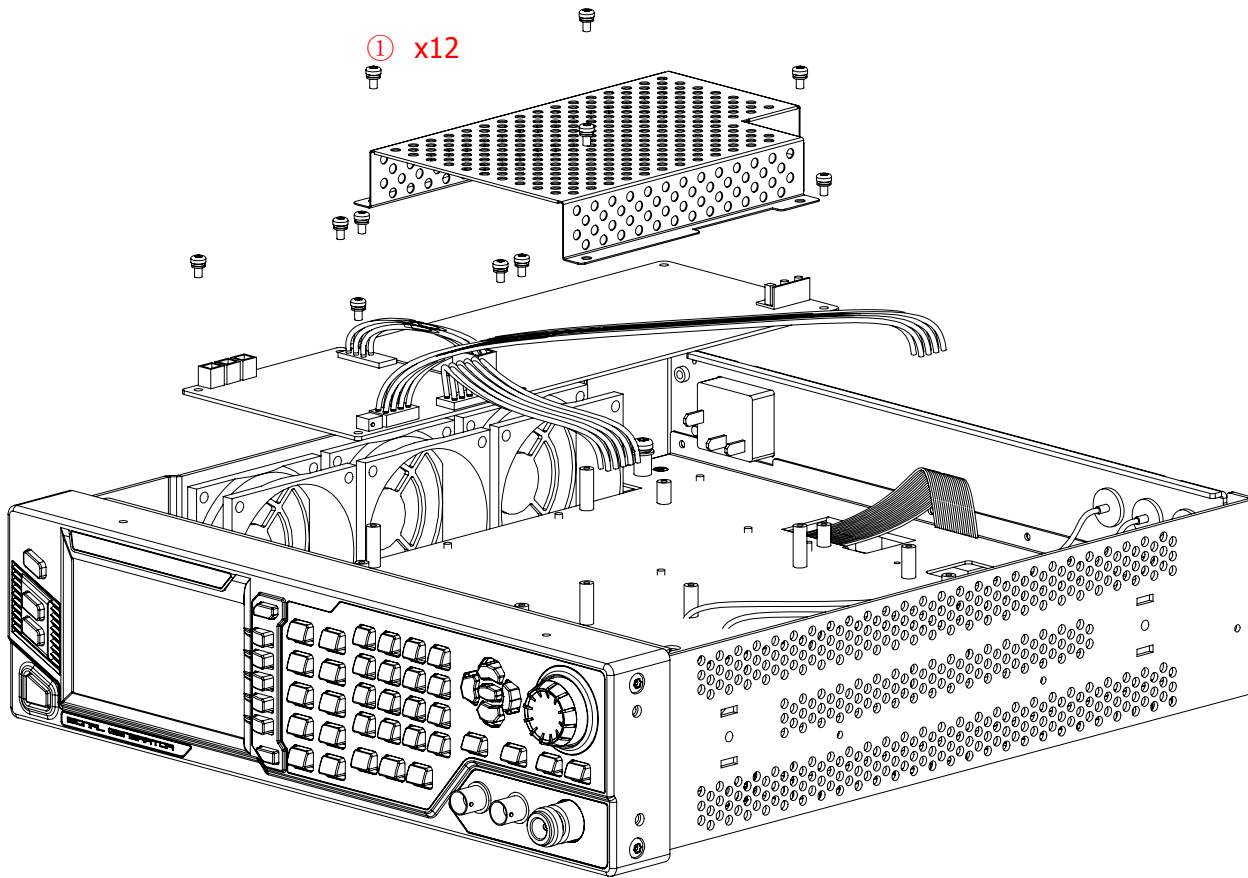

Figure 1-8 Disassemble the Shield and Power Supply Board

### Part Description:

- ① 12 screws (M3\*6 torx pan head combination screw, used for fastening the shield and power supply board)

### Disassembly Steps:

1. Disconnect the cables from the power module.
2. Use the T10 screwdriver to remove all the screws that secure the shield and power supply board.
3. Remove the shield gently.
4. Remove the power supply board gently.

### Tip:

Before disassembling the power supply module, pay attention to the connecting positions of the cables on the power supply module to avoid incorrect connection or incomplete connection when assembling the cables.

## Disassemble the Output Signal Cable

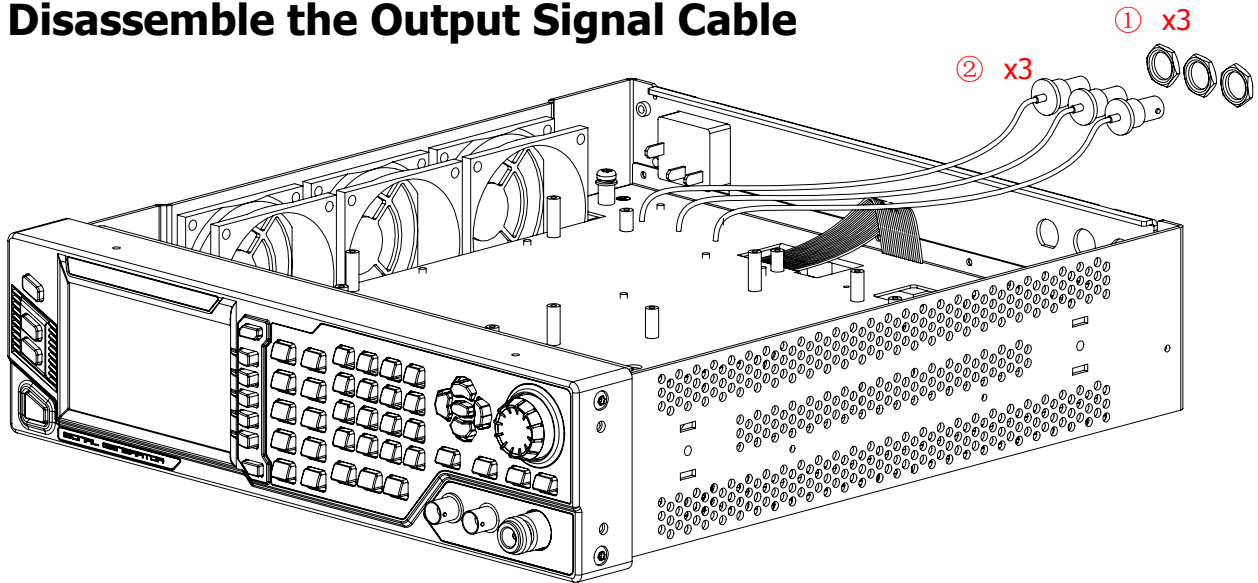

Figure 1-9 Disassemble the Output Signal Cable

### Part Description:

- ① 3 output signal cables
- ② 3 BNC nuts

### Disassembly Steps:

1. Use the BNC socket wrench to remove the BNC nuts that secure the cables.
2. Remove the output signal cables gently.

**Tip:**

Before removing the output signal cables, pay attention to the connecting positions of the cables to avoid incorrect connection or incomplete connection when assembling the cables.

## Disassemble the Front Panel Assembly

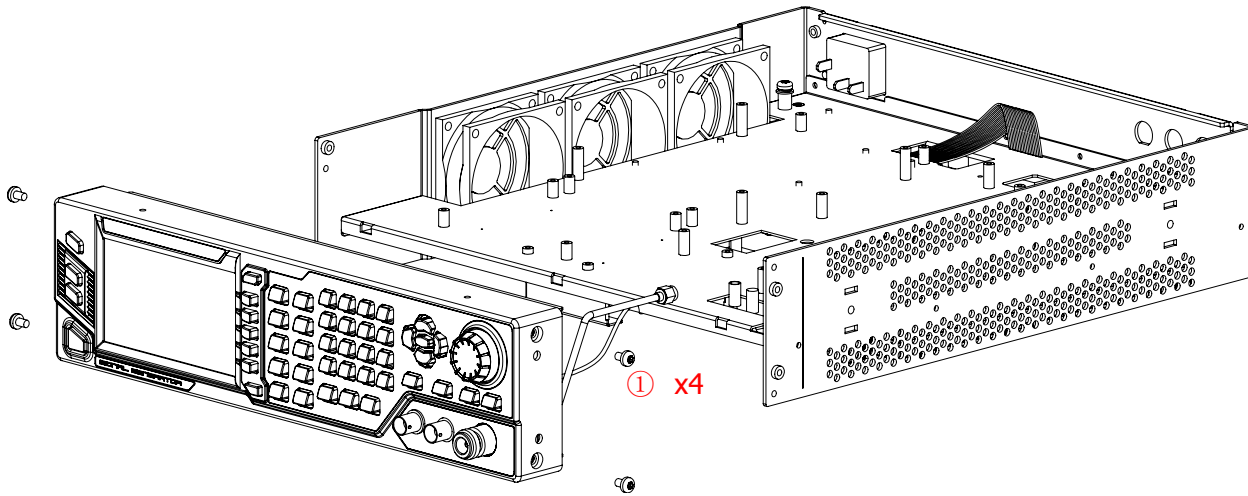

Figure 1-10 Disassemble the Front Panel Assembly

### Part Description:

- ① 4 screws (M4\*8 torx pan head screw, used for fastening the front panel assembly)

### Disassembly Steps:

1. Use the T20 screwdriver to remove all the screws that secure the front metal panel and the front panel.
2. Remove the front panel assembly gently.

### Tip:

Before removing the cables on the front panel assembly, pay attention to the connecting positions of the cables to avoid incorrect connection or incomplete connection when assembling the cables.

## Disassemble the PCIE Cables

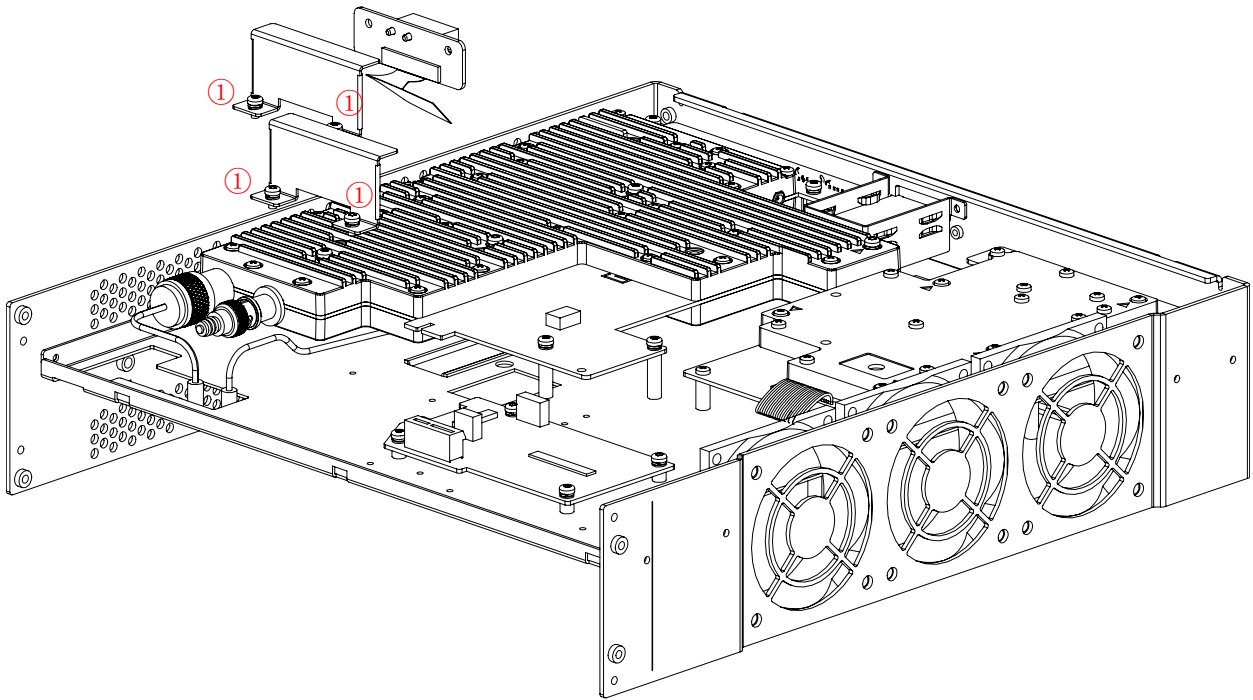

Figure 1-11 Disassemble the PCIE Cables

### Part Description:

- ① 4 screws (M3\*6 torx pan head combination screw, used for fastening the PCIE brackets)

### Disassembly Steps:

1. Use the T10 screwdriver to remove 4 screws that secure the two PCIE brackets.
2. Remove the PCIE cables gently.

### Tip:

Before removing the PCIE cables, pay attention to the connecting positions of the cables to avoid incorrect connection or incomplete connection when assembling the cables.

## Disassemble the Digital Module

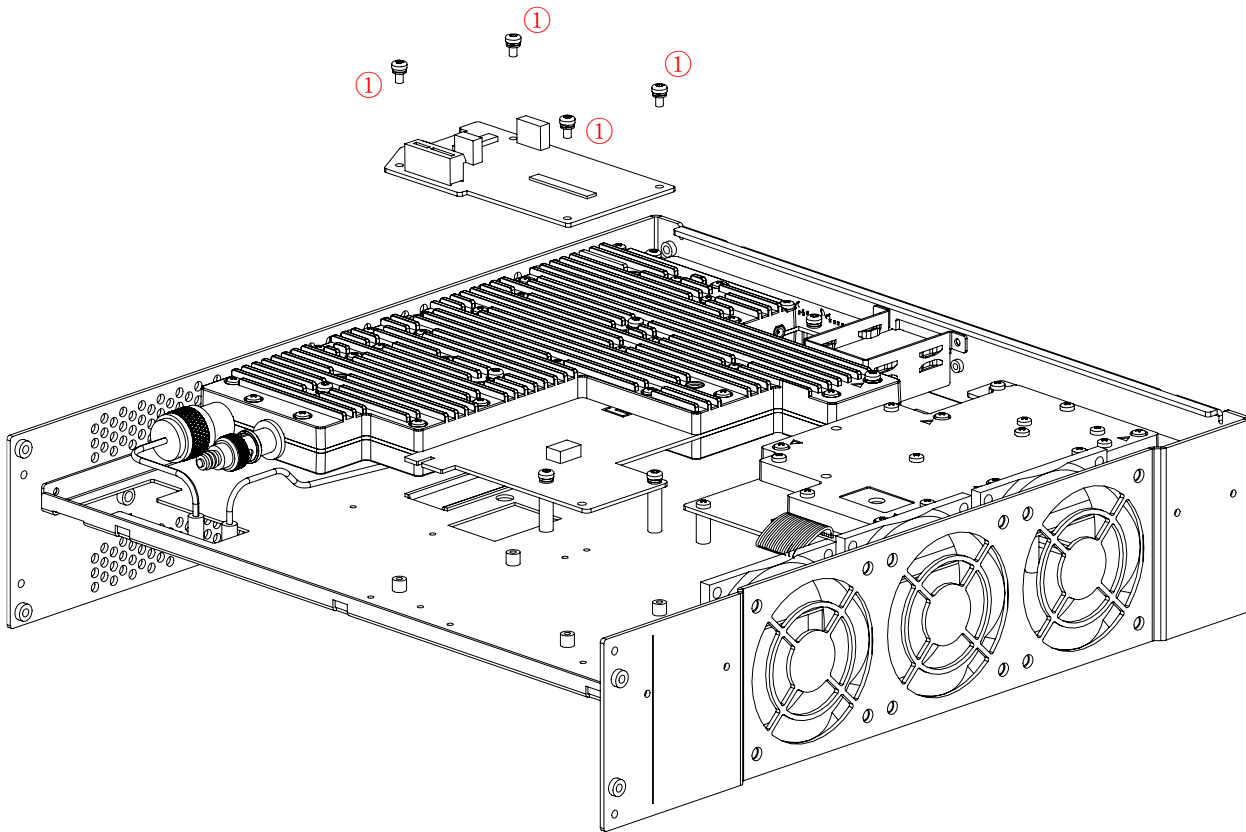

Figure 1-12 Disassemble the Digital Module

### Part Description:

- ① 4 screws (M3\*6 torx pan head combination screw, used for fastening the digital module)

### Disassembly Steps:

1. Use the T10 screwdriver to remove all the screws that secure the digital module.
2. Remove the digital module gently.

### Tip:

Before disassembling the digital module, pay attention to the connecting positions of the cables to avoid incorrect connection or incomplete connection when assembling the cables.

## Disassemble the OCXO Module

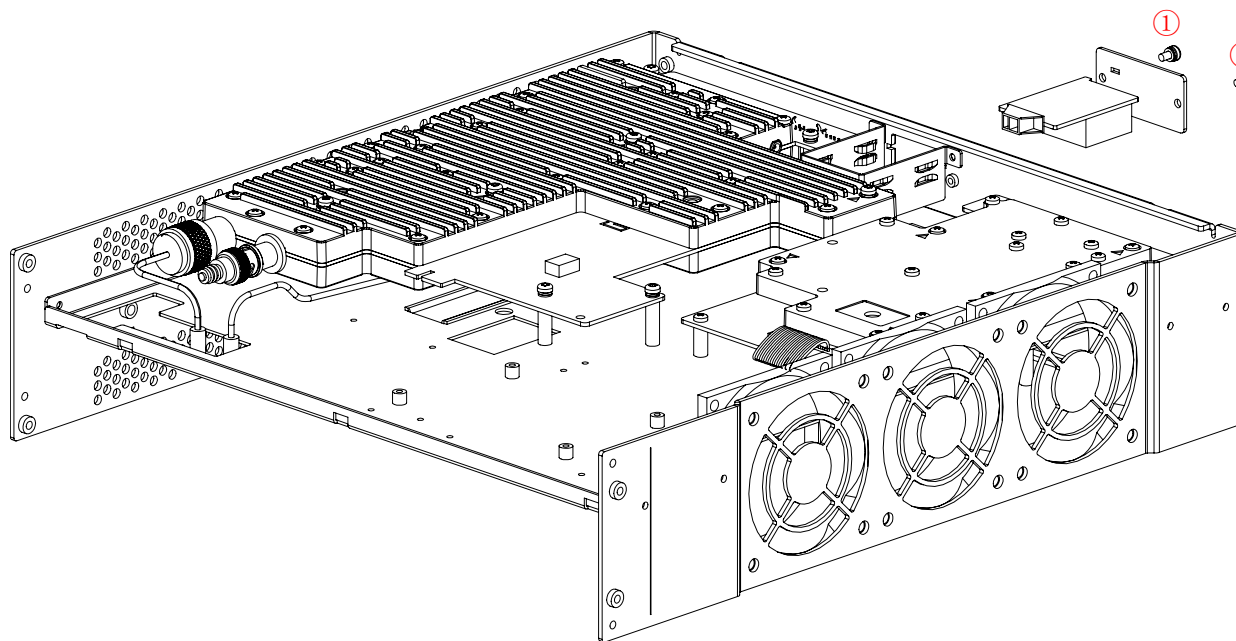

Figure 1-13 Disassemble the OCXO Module

### Part Description:

- ① 2 screws (M3\*6 torx pan head combination screw, used for fastening the OCXO plate)

### Disassembly Steps:

1. Use the T10 screwdriver to remove all the screws that secure the OCXO plate.
2. Remove the OCXO module gently.

## Disassemble the RF Module

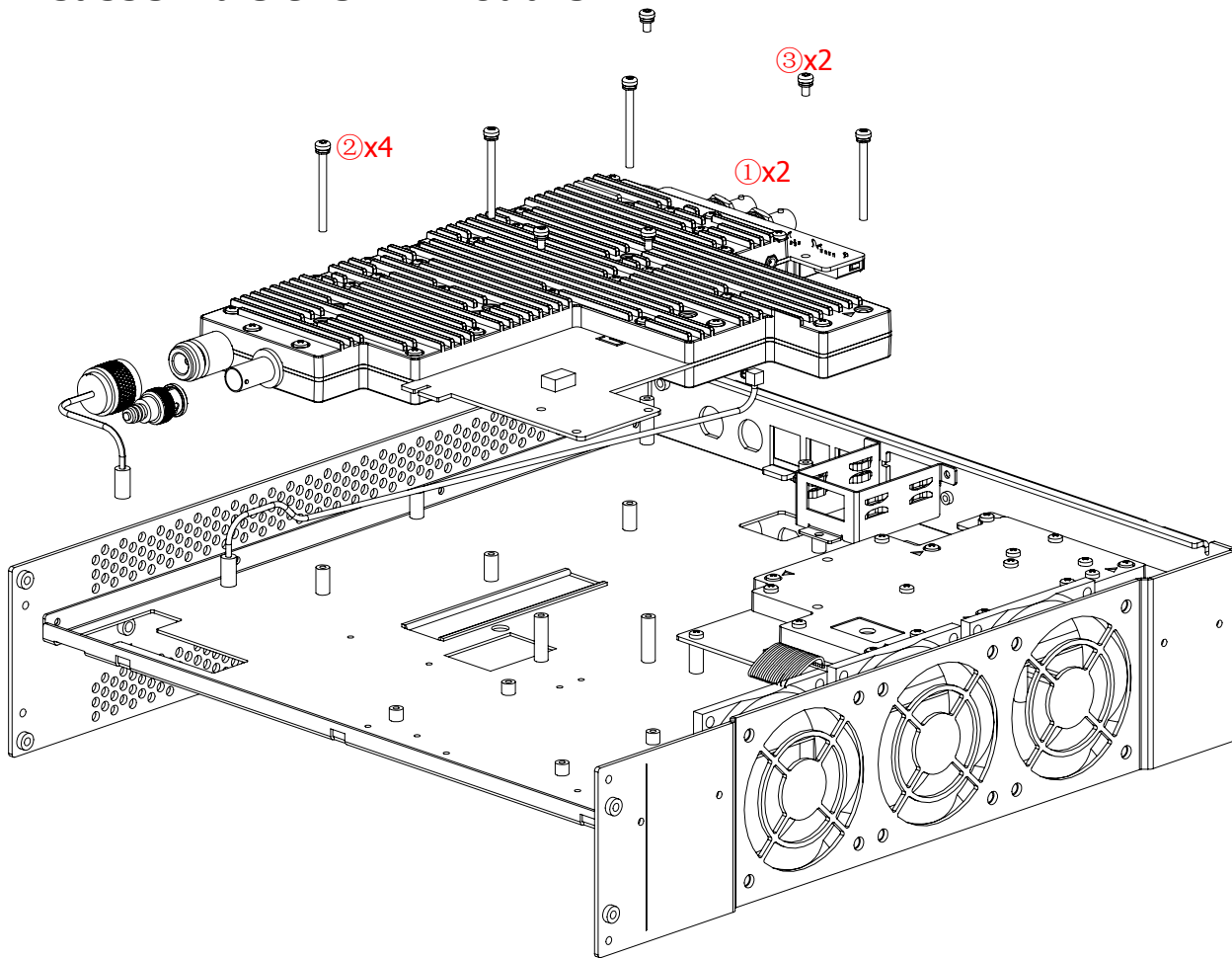

Figure 1-14 Disassemble the RF Module

### Part Description:

- ① 2 BNC nuts (used for securing the BNC connectors)
- ② 4 screws (M3\*35 torx pan head combination screw, used for fastening the RF module)
- ③ 2 screws (M3\*6 torx pan head combination screw, used for fastening the RF module)

### Disassembly Steps:

1. Use the BNC socket wrench to remove the BNC nuts and washers for securing the BNC connectors.
2. Use the T10 screwdriver to remove all the screws that secure the RF module.
3. Remove the RF module gently.

### Tip:

Before disassembling the RF module, pay attention to the connecting positions of the cables to avoid incorrect connection or incomplete connection when assembling the cables.



## Disassemble the IQ Module

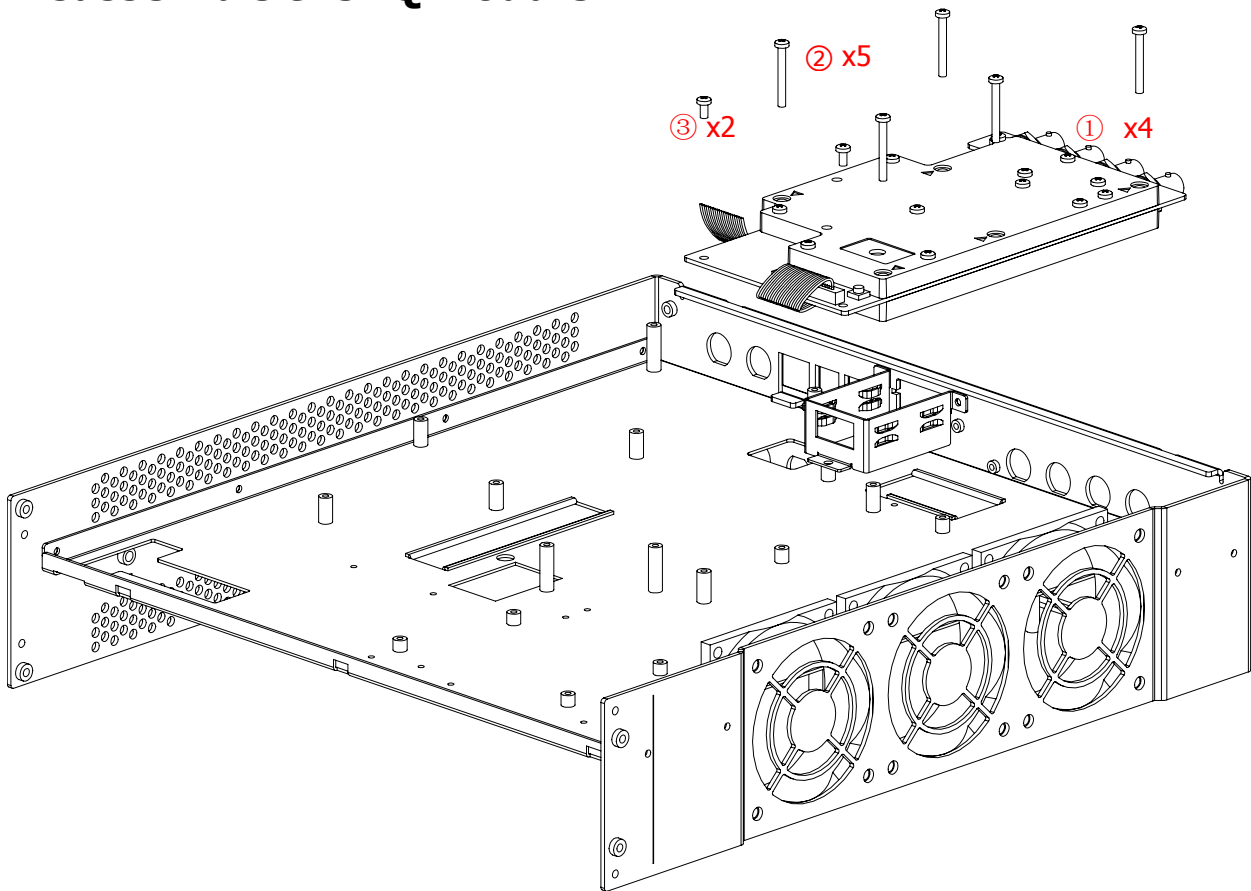

Figure 1-15 Disassemble the IQ Module

### Part Description:

- ① 4 BNC nuts (used for securing the BNC connectors)
- ② 5 screws (M3\*20 torx pan head combination screw, used for fastening the IQ module)
- ③ 2 screws (M3\*6 torx pan head combination screw, used for fastening the IQ module)

### Disassembly Steps:

1. Use the BNC socket wrench to remove the BNC nuts and washers for securing the BNC connectors.
2. Use the T10 screwdriver to remove all the screws that secure the IQ module.
3. Remove the IQ module gently.

### Tip:

Before disassembling the IQ module, pay attention to the connecting positions of the cables to avoid incorrect connection or incomplete connection when assembling the cables.

## Disassemble the Fan

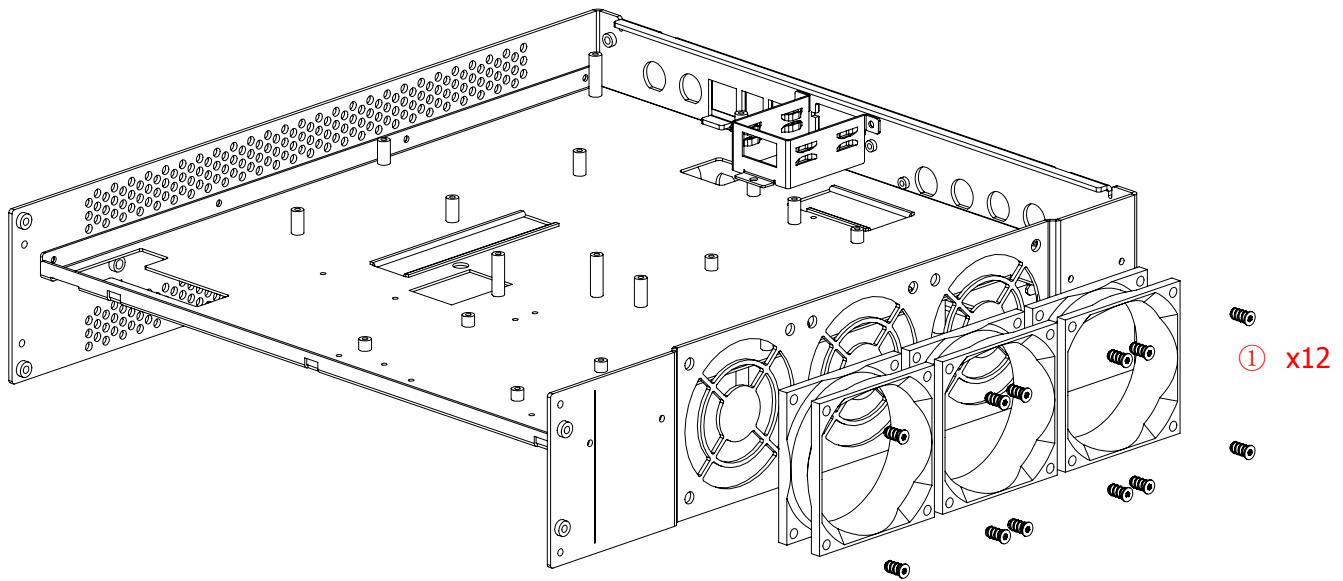

Figure 1-16 Disassemble the Fan

### Part Description:

- ① 12 screws (ST5\*10 torx flat countersunk head self-tapping screw, used for fastening the fan)

### Disassembly Steps:

1. Use the T10 screwdriver to remove all the screws that secure the fan.
2. Take off the fan gently.

### Tip:

When disassembling the fan, pay attention to the installation position of the fan and the direction of the fan cable outlet to avoid any improper assembly operation.

## Disassemble the Panel

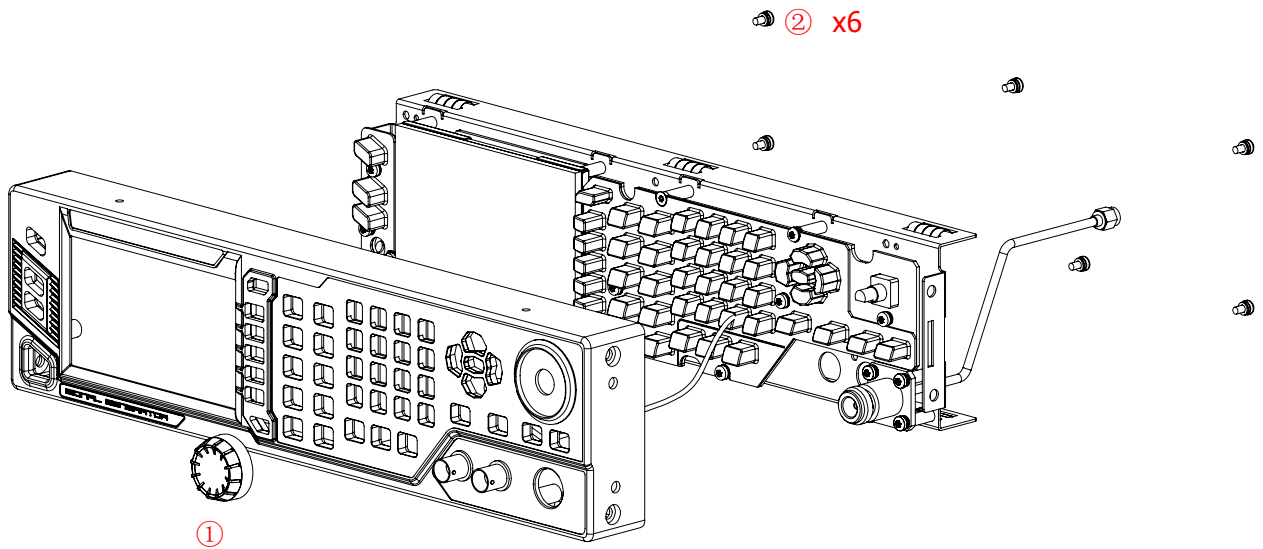

Figure 1-17 Disassemble the Panel

### Part Description:

- ① Knob
- ② 6 screws (M3\*6 torx pan head combination screw, used for fastening the front panel)

### Disassembly Steps:

1. Pull out the knob from the front panel.
2. Use the T10 screwdriver to remove all the screws that secure the front metal panel and the front panel.
3. Remove the front panel gently.

## Disassemble the LCD

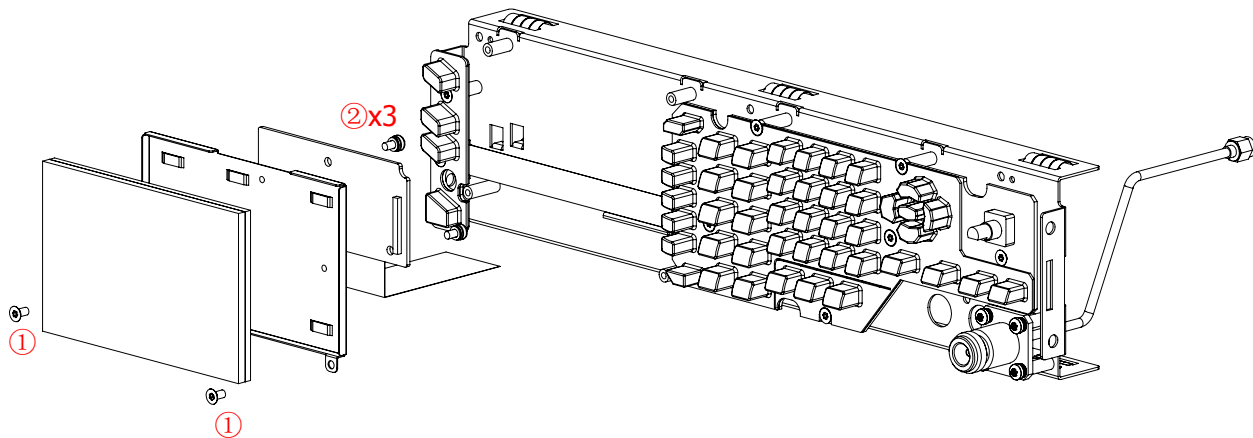

Figure 1-18 Disassemble the LCD

### Part Description:

- ① 2 screws (M3\*6 torx flat head countersunk screw, used for fastening the LCD)
- ② 3 screws (M3\*6 torx pan head combination screw, used for fastening the PCB board)

### Disassembly Steps:

1. Use the T10 screwdriver to remove all the screws that secure the LCD assembly.
2. Remove the LCD assembly from the front metal panel.
3. Remove the screws from the LCD shield and remove the PCB board.

### Tip:

Before disassembling the LCD assembly, pay attention to the connecting positions of the cables to avoid incorrect connection or incomplete connection when assembling the cables.

## Disassemble the Keypad Board

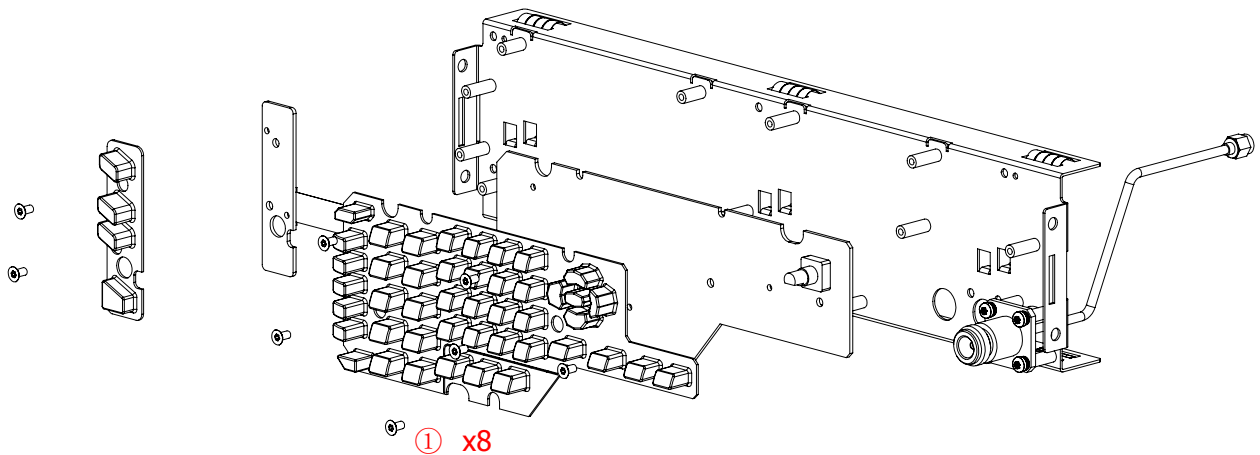

Figure 1-19 Disassemble the Keypad Board

### Part Description:

- ① 8 screws (M3\*6 torx flat head countersunk screw, used for fastening the keypad board)

### Disassembly Steps:

1. Use the T10 screwdriver to remove all the screws that secure the keypad board.
2. Remove the keypad board gently.

**Tip:**

Before disconnecting the cables from the keypad board, pay attention to the connecting positions of the cables to avoid incorrect connection or incomplete connection when assembling the cables.

## Disassemble the Nut Connector

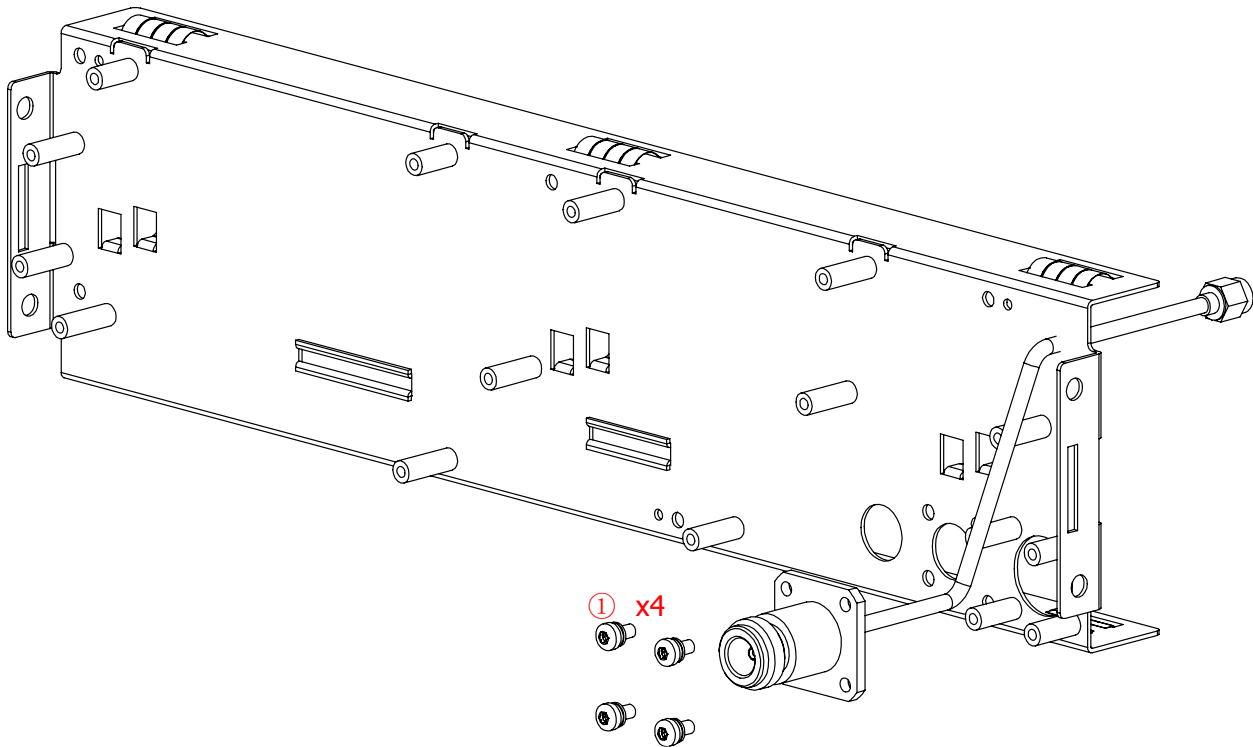

Figure 1-20 Disassemble the Nut Connector

### Part Description:

- ① 4 screws (M3\*8 torx pan head combination screw, used for fastening the nut connector)

### Disassembly Steps:

1. Use the T10 screwdriver to remove all the screws that secure the nut connector.
2. Remove the nut connector gently.

## Assembly Procedures

The assembly procedures are simply the reversal of the disassembly procedures. Check whether the cables are correctly connected and whether all the screws are installed after completing each assembly procedure.

**To avoid causing damage to the instrument due to improper operation and to save your time, we recommend you to follow the disassembly steps and methods in this guide manual.**





# Chapter 2 Troubleshooting&Maintenance

## Basic Troubleshooting

The chapter lists the commonly encountered failures and their solutions. When you encounter those problems, please solve them following the corresponding steps. If the problem remains still, please contact **RIGOL** and provide your device information (**System** → **Information** → **System Info**).

### 1. The screen of the RF signal generator is still dark (no display) after pressing the power key.

- (1) Check whether the fan is running;
  - If the fan is running but the screen is dark, the screen connecting wire might be loose.
  - If the fan is not running and the instrument does not start successfully, please go to step (2).
- (2) Check whether the power is correctly connected and the power switch is really on.
- (3) Check whether the fuse is burned out. If the fuse needs to be replaced, please use the specified fuse (AC 250V, T2A).
- (4) Restart the instrument after finishing the above inspections.
- (5) If it still does not work correctly, please contact **RIGOL**.

### 2. The screen is too dark and cannot be seen clearly.

- (1) Check whether the brightness setting of the LCD screen is too low.
- (2) Press **System** → **Display** → **Brightness** and use the numeric keys or up/down arrow keys to adjust the brightness of the LCD screen of the RF signal generator to a proper value.

### 3. The RF signal generator is locked.

- (1) Check whether the RF signal generator is in remote control mode (in remote control, **Rmt** is displayed in the status bar of the user interface). Pressing **Esc** can exit the remote control mode and unlock the front panel.
- (2) Check whether the RF signal generator is in local mode with the screen being locked (when the screen is locked, front panel operations are not available). Pressing **Esc** can unlock the screen and exit the locking state.
- (3) If progress bar is displayed on the screen of the signal generator, some operation is in progress. For example, when saving a file, the progress bar will be displayed indicating that the save operation is in progress. At this point, the front panel is locked.
- (4) Pressing **Preset** or restarting the signal generator can also unlock the instrument.

### 4. The setting is correct but the waveform output is incorrect.

- (1) There is no RF output.
  - Check whether the signal connecting cable is tightly connected to the corresponding **[RF OUTPUT 50Ω]** connector.
  - Check whether the connecting cable has internal damage.
  - Check whether the connecting cable is tightly connected to the test instrument.
  - Check whether the backlight of **[RF]** lights on. If not, press this key to illuminate the backlight. At this point, the RF label is displayed in the status bar of the user interface and the RF output is enabled.
  - Check whether the output amplitude of the RF signal is too small. Adjust the output amplitude properly.
- (2) The RF output is not modulated.
  - Check whether the signal connecting cable is tightly connected to the corresponding **[RF OUTPUT 50Ω]** connector.
  - Check whether the connecting cable has internal damage.
  - Check whether the connecting cable is tightly connected to the test instrument.

- Check whether the backlights of **MOD** and **RF** are both illuminated and check whether the modulation **Switch** is set to "On".
- Check whether the modulation parameter setting is correct and adjust the parameter appropriately.
- If external modulation source is used, make sure that the external source is correctly connected and outputs signal. At the same time, the external source should work within the specified range of the signal generator.

## 5. The sweep is abnormal.

### (1) The sweep stagnates.

The sweep progress bar is displayed in the frequency area/amplitude area in the user interface indicating that the sweep is in progress. If the sweep stagnates, please check the following points.

- At least one manner of sweep is enabled. Press **SWEEP** → **Sweep** to select "Freq", "Level" or "Freq & Level".
- If single sweep mode is selected, press **Single** and the instrument performs a sweep if the trigger condition is met.
- If the sweep trigger mode is not set to auto, press **SWEEP** → **Trig** → "Auto" to make sure whether the sweep stagnates due to the loss of sweep trigger.
- If the point trigger mode is not set to auto, press **SWEEP** → **Point Trig** → "Auto" to make sure whether the sweep stagnates due to the loss of point trigger.
- Make sure whether the dwell time is too large or too small that the sweep cannot be seen.
- Make sure that at least two points are set in the step sweep or list sweep.

### (2) The dwell time of list sweep is incorrect.

- Press **SWEEP** → **List Swp** to enter the sweep list editing interface.
- Make sure whether the dwell time of the list sweep is correct.
- If the dwell time is incorrect, re-edit it. If it is correct, turn to the next step.
- Press **SWEEP** → **Sweep Type** to make sure that "List" sweep is selected. If "Step" sweep is currently selected, the signal generator sweeps according to the dwell time of the step sweep.

### (3) The list sweep information recalled from the register is lost.

- The list sweep information cannot be stored in the status register of the instrument as a part of the instrument state.
- The signal generator can only use the current list for sweep and you can store the list sweep data to the local directory of the instrument.

### (4) In list or step sweep, the amplitude does not change.

- Make sure that the sweep manner is set to "Level" or "Freq&Level".
- If the sweep manner is currently set to "Freq", the amplitude will not change.

## 6. The USB storage device cannot be recognized.

- (1) Check whether the USB storage device can work normally when connected to other instruments or PCs.
- (2) Make sure that the USB storage device used is a Flash type. This instrument does not support hardware USB storage device.
- (3) Restart the instrument and insert the USB storage again to check whether it can work normally.
- (4) If the USB storage device still cannot be used normally, please contact **RIGOL**.

## 7. No response or incorrect response when key is pressed.

- (1) After starting the instrument, make sure that whether all the keys are irresponsive.
- (2) Press **System** → **Self-test** → **Key Test** to enter the keyboard test interface. Press the function keys on the front panel sequentially and check whether some key gives no response or incorrect response when it is pressed.

- (3) If the above failures occur, the keyboard connecting wire might be loose or the keyboard is damaged. Please do not disassemble the instrument and contact **RIGOL**.

#### **8. Performance specification test is not passed.**

- (1) Check whether the RF signal generator is within calibration period (1 year).
- (2) Make sure that the RF signal generator is warmed up for at least 40 minutes before test.
- (3) Check whether the RF signal generator is under the specified temperature.
- (4) Check whether the test is being performed in a highly magnetic environment.
- (5) Check whether the power supplies of RF signal generator and test system have strong interference.
- (6) Check whether the performance of the test device meets the requirement.
- (7) Make sure that the test device is within calibration period.
- (8) Check whether the test device meets the required conditions of the manual.
- (9) Check whether all connections are tight.
- (10) Check whether all cables have internal damage.
- (11) Make sure that the operations conform to settings and processes which are required by the performance verification manual.
- (12) Check whether the error calculation is a mistake.
- (13) The definitions of "Typical Value" and "Nominal Value" for this product should be correctly understood.
  - Typical Value: the performance specification of this product under specified conditions.
  - Nominal Value: the approximate quantity of the product during application.

## Maintenance

### System Maintenance

In order to ensure the performance and prolong the service life of the instrument, please follow the recommendations below.

1. Get a full understanding of the instrument performance and its basic operating method before using it.
2. In order to ensure the measurement accuracy and prolong the service life of the instrument, protect the instrument against dust, shock, moisture, magnetic field, and static electricity. Moreover, the instrument should not be exposed to sunlight for long periods of time.
3. Do not operate the instrument with functional failures. If a certain function of the instrument fails to work normally during its operating period, locate the problem and resolve it, then you can continue to operate the instrument. Besides, regular test and calibration should be performed to ensure the accuracy of its performance.
4. Arrange the instrument properly after you complete the operation.
5. Keep instrument accessories properly for future use.

### Warranty

**RIGOL** TECHNOLOGIES CO., LTD. (hereinafter referred to as **RIGOL**) warrants that the product will be free from defects in materials and workmanship within the warranty period. If a product proves defective within the warranty period, **RIGOL** guarantees free replacement or repair for the defective product.

To get repair service, please contact with your nearest **RIGOL** sales or service office.

There is no other warranty, expressed or implied, except such as is expressly set forth herein or other applicable warranty card. There is no implied warranty of merchantability or fitness for a particular purpose. Under no circumstances shall **RIGOL** be liable for any consequential, indirect, ensuing, or special damages for any breach of warranty in any case.

## Care and Cleaning

### Care

Do not store or leave the instrument where it may be exposed to direct sunlight for long periods of time.

### Cleaning

Clean the instrument regularly according to its operating conditions.

1. Disconnect the instrument from all power sources.
2. Clean the external surfaces of the instrument with a soft cloth dampened with mild detergent or water. Avoid having any water or other objects into the chassis via the heat dissipation hole. When cleaning the LCD, take care to avoid scarifying it.



---

**CAUTION**

To avoid damage to the instrument, do not expose it to caustic liquids.

---



---

**WARNING**

To avoid short-circuit resulting from moisture or personal injuries, ensure that the instrument is completely dry before connecting it to the power supply.

---

## Environmental Considerations

The following symbol indicates that this product complies with the WEEE Directive 2002/96/EC.



### Product End-of-Life Handling

The equipment may contain substances that could be harmful to the environment or human health. To avoid the release of such substances into the environment and avoid harm to human health, we recommend you to recycle this product appropriately to ensure that most materials are reused or recycled properly. Please contact your local authorities for disposal or recycling information.