

RIGOL

Declassification Guide

Function/Arbitrary Waveform Generator

May 2012

RIGOL Technologies, Inc.

DG4000 Series

DG4000 series function/arbitrary waveform generator consists of DG4162, DG4102 and DG4062.

Instrument Memory

This section contains information on the types of memory available in your instrument. It explains the size of memory, how it is used, its location, volatility and the clearing procedure.

Instrument memory:

Memory type and size	Writable during normal operation	Data retained when powered off	Purpose/ contents	Data input method	Location in instrument and remarks	Sanitization procedure
FRAM 2kB	Yes	Yes	System setting	Operating system	Main board in CPU area	Default all settings
Main Memory (SDRAM) 4MB	Yes	No	Program	Operating system	Main Board in CPU area	Cycle power
Data Memory (SDRAM) 28MB	Yes	No	System data	System	Main board in CPU area	Cycle power
Main Code (Nor Flash) 3MB	No	Yes	System firmware	Firmware upgrade	Main board in CPU area	No user data is stored
FPGA Firmware (Nor Flash) 1MB	No	Yes	FPGA firmware loaded into the FPGA by boot loader	Firmware upgrade	Main board in CPU area	No user data is stored
System Data (Nor Flash) 11MB	No	Yes	Image\ Font\ Message\ Inner wave data	Firmware upgrade	Main board in CPU area	No user data is stored

Instrument memory (continue)

Memory type and size	Writable during normal operation	Data retained when powered off	Purpose/ contents	Data input method	Location in instrument and remarks	Sanitization procedure
Calibration Data (Nor Flash) 512kB	No	Yes	Calibration data	Calibration	Main board in CPU area	
User Data (Nor Flash) 512kB	Yes	Yes	State file \Arb Wave	Storage	Main board in CPU area	Clear the user data
DDR2 64MB	Yes	No	FPGA Code\ GUI Display caches	System	Main board in CPU area	Cycle power

Position of Instrument Memory on Main Board

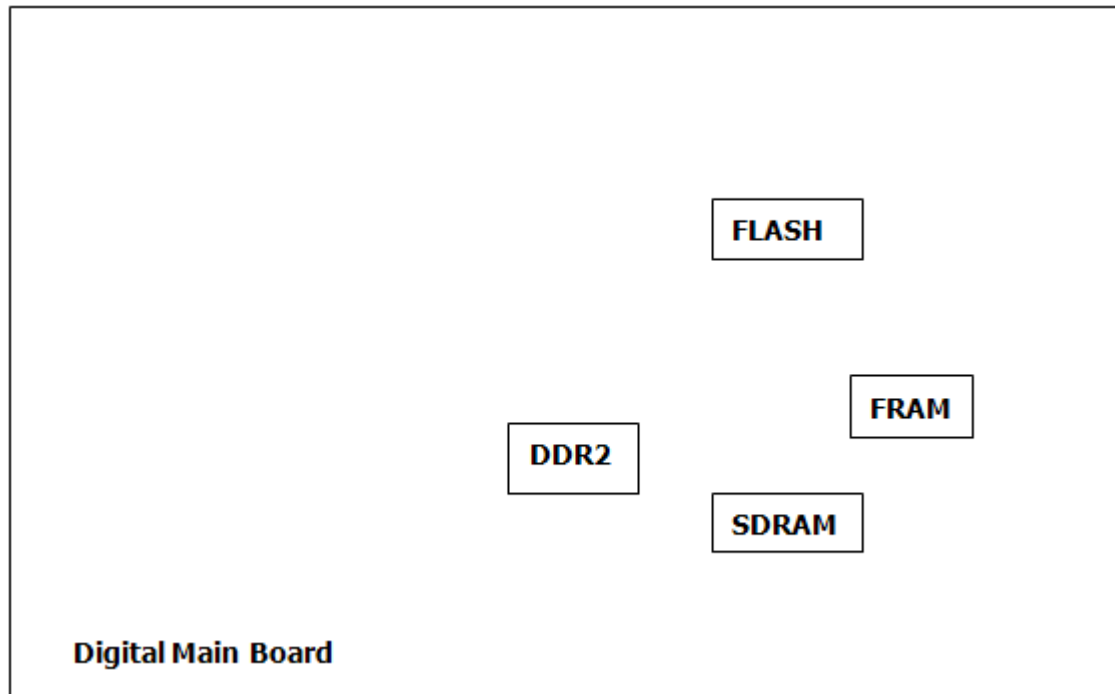

DG5000 Series

DG5000 series function/arbitrary waveform generator consists of DG5352, DG5351, DG5252, DG5251, DG5102, DG5101, DG5072 and DG5071.

Instrument Memory

This section contains information on the types of memory available in your instrument. It explains the size of memory, how it is used, its location, volatility and the clearing procedure.

Instrument memory:

Memory type and size	Writable during normal operation	Data retained when powered off	Purpose/ contents	Data input method	Location in instrument and remarks	Sanitization procedure
FRAM 2kB	Yes	Yes	System setting	Operating System	Main board in CPU area	Default all settings
Main Memory (SDRAM) 3MB	Yes	No	Program	Operating System	Main board in CPU area	Cycle power
Data Memory (SDRAM) 13MB	Yes	No	System data	System	Main board in CPU area	Cycle power
Main Code (Nor Flash) 3MB	No	Yes	System firmware	Firmware upgrade	Main board in CPU area	No user data is stored
FPGA Firmware (Nor Flash) 1.5MB	No	Yes	FPGA firmware loaded into the FPGA by boot loader	Firmware upgrade	Main board in CPU area	No user data is stored
System Data (Nor Flash) 11MB	No	Yes	Image\ Font\ Message\ Inner wave data	Firmware upgrade	Main board in CPU area	No user data is stored

Instrument memory (continue)

Memory type and size	Writable during normal operation	Data retained when powered off	Purpose/ contents	Data input method	Location in instrument and remarks	Sanitization procedure
Calibration Data (Nor Flash) 512kB	No	Yes	Calibration data	Calibration	Main board in CPU area	
Nand Flash 1GB	Yes	Yes	Public fat disk	System	Main board in CPU area (Back)	Secure erase
DDR2 64MB	Yes	No	Arbitrary wave caches	System	Analog Board FPGA area	Cycle power
SDRAM 16MB	Yes	No	GUI display caches	System	Main board in CPU area	Cycle power

Position of Instrument Memory on Main Board

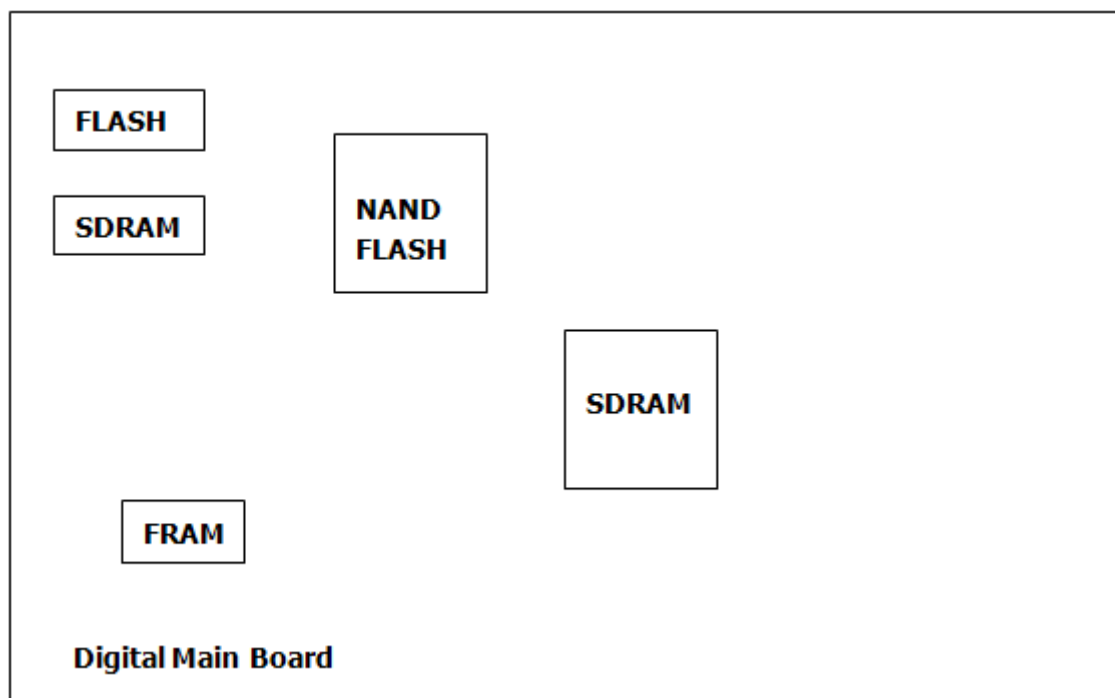

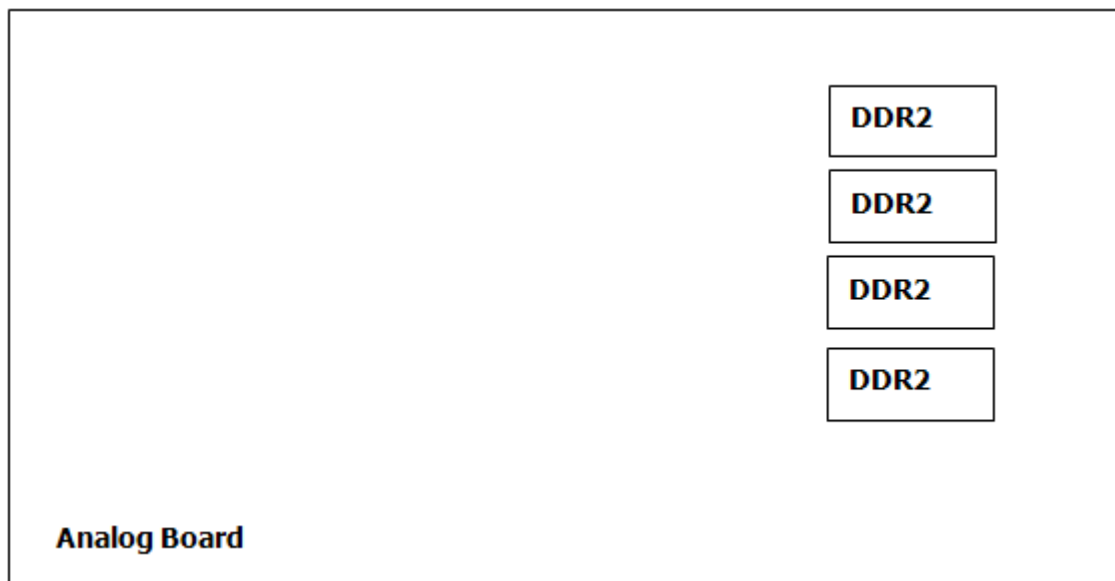

DG1000 Series

DG1000 series function/arbitrary waveform generator consists of DG1022 and DG1022A.

Instrument Memory

This section contains information on the types of memory available in your instrument. It explains the size of memory, how it is used, its location, volatility and the clearing procedure.

Instrument memory:

Memory type and size	Writable during normal operation	Data retained when powered off	Purpose/ contents	Data input method	Location in instrument and remarks	Sanitization procedure
FRAM 2kB	Yes	Yes			Main board in CPU area	
Main Memory (SDRAM) 2MB	Yes	No	Program	Operating system	Main board in CPU area	Cycle power
Data Memory (SDRAM) 14MB	Yes	No	System data\LCD caches	System	Main board in CPU area	Cycle power
Main Code (Nor Flash) 1.5MB	No	Yes	System firmware	Firmware upgrade	Main board in CPU area	No user data is stored
System Data (Nor Flash) 2MB	Yes	Yes	Image\ Font\ Message\ Inner wave data\ Calibration	Firmware upgrade\ Calibration	Main board in CPU area	No user data is stored
User Data (Nor Flash) 512kB	Yes	Yes	State file\ Arb wave	Storage	Main board in CPU area	Clear the user data
SPIFLASH 256kB	No	Yes	FPGA firmware	Firmware upgrade	Main board in FPGA area	No user data is stored

Position of Instrument Memory on Main Board

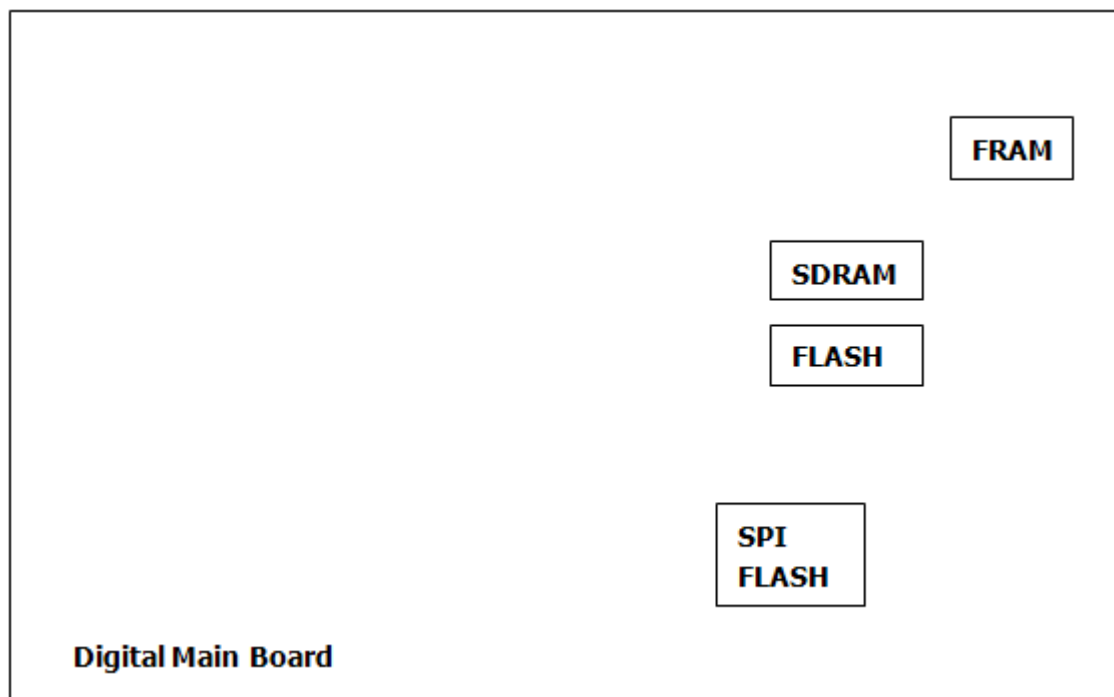

DG2000 Series

DG2000 series function/arbitrary waveform generator consists of DG2041A.

Instrument Memory

This section contains information on the types of memory available in your instrument. It explains the size of memory, how it is used, its location, volatility and the clearing procedure.

Instrument memory:

Memory type and size	Writable during normal operation	Data retained when powered off	Purpose/ contents	Data input method	Location in instrument and remarks	Sanitization procedure
FRAM 2kB	Yes	Yes			Main board in CPU area	
Main Memory (SDRAM) 2MB	Yes	No	Program	Operating system	Main board in CPU area	Cycle power
Data Memory (SDRAM) 14MB	Yes	No	System data\LCD caches	System	Main board in CPU area	Cycle power
Main Code (Nor Flash) 1.5MB	No	Yes	System firmware	Firmware upgrade	Main board in CPU area	No user data is stored
System Data (Nor Flash) 2MB	Yes	Yes	Image\ Font\ Message\ Inner wave data\ Calibration	Firmware upgrade\ Calibration	Main board in CPU area	No user data is stored
User Data (Nor Flash) 512kB	Yes	Yes	State file\ Arb wave	Storage	Main board in CPU area	Clear the user data
SPI FLASH 256kB	No	Yes	FPGA firmware	Firmware upgrade	Main board in FPGA area	No user data is stored

Position of Instrument Memory on Main Board

