

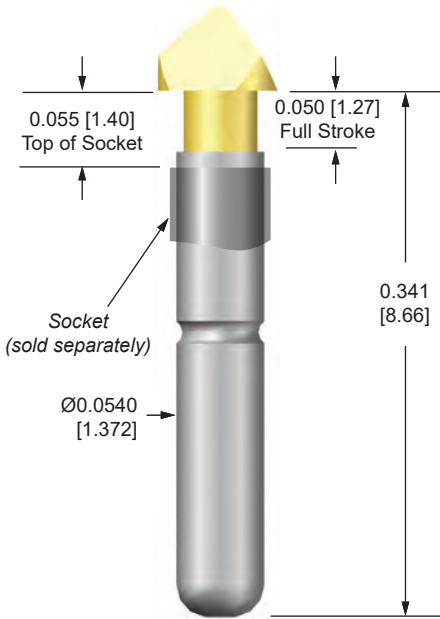

100-05 Series 0.100 [2.54] Centers | 0.050 [1.27] Full Stroke

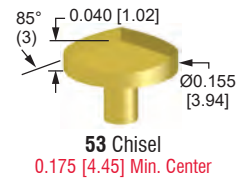

CHISEL

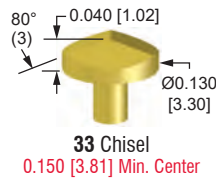
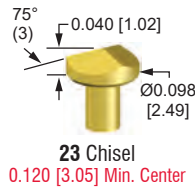
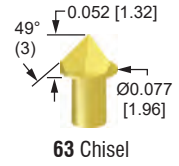
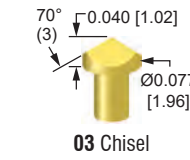
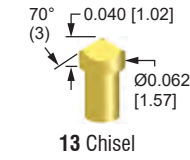

ROUND

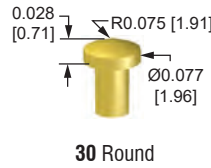
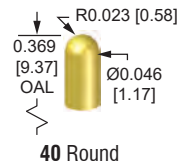

CUP

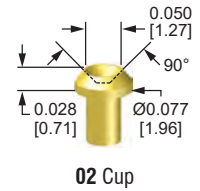

PROBE P/N 100-PL05 example: 100-PLP0503L

Tube	Letter	Material/Finish	Average Resistance	Current Rating AMPS ¹ 120°C (204°C) ³		
	P ²	Nickel silver/ID precious metal clad	< 45 mOhms	13.2 (18.1) ³		
N	Nickel silver/no finish	< 65 mOhms	12.0 (18.5) ³			
Tip Style	Digits	Material/Finish				
	See Tips	Heat treated BeCu/plated gold over nickel.				
Spring	Letter	Spring Force	Preload	@ 0.050 [1.27] Stroke	Material	Cycle Life @ 0.050 [1.27] Stroke
	L	Low	0.7 [20g/0.19N]	2.0 [57g/0.56N]	SS	1,000,000
	S	Standard	1.3 [37g/0.36N]	4.5 [128g/1.25N]	MW	1,000,000
	H	High	2.7 [77g/0.75N]	6.5 [184g/1.81N]	SS	1,000,000

¹ Current rating is affected by spring material and lubrication choice. Please refer to Current Carrying Capacity and Testing in Extreme Working Temperature applications notes for more details.

² P tube has Ø0.016 [0.41] hole in end for identification only.

³ Working Temperature Range: up to 120°C. SS springs can be used up to 204°C.

SPRING FORCE

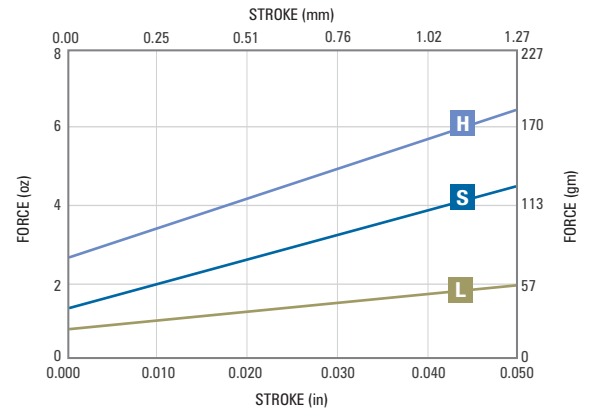

TOOLS & ACCESSORIES

See pages 75-79 for order information.

SOCKETS

Suggested mounting holes and drill sizes in AT7000, G10/FR4 or similar materials should be gauged at: 0.0670 / 0.0690 [1.702 / 1.753]; Drill Size 1.75mm

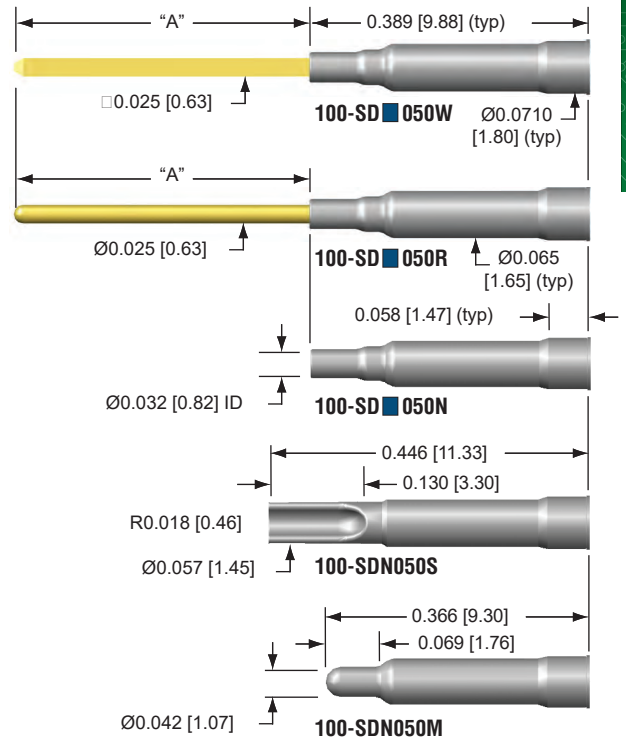

TIP STYLE	HEAD LENGTH	DISTANCE FROM TOP OF SOCKET TO TIP	OVERALL PROBE LENGTH
02	0.028 [0.71]	0.083 [2.11]	0.369 [9.37]
03	0.040 [1.02]	0.095 [2.41]	0.381 [9.68]
13	0.040 [1.02]	0.095 [2.41]	0.381 [9.68]
23	0.040 [1.02]	0.095 [2.41]	0.381 [9.68]
30	0.028 [0.71]	0.083 [2.11]	0.369 [9.37]
33	0.040 [1.02]	0.095 [2.41]	0.381 [9.68]
40	-	0.083 [2.11]	0.369 [9.37]
53	0.040 [1.02]	0.095 [2.41]	0.381 [9.68]
63	0.052 [1.32]	0.107 [2.72]	0.393 [9.98]

SOCKET P/N

100-SD 050 example: 100-SDN050S

Tube	Letter	Material/Finish	
	G	Nickel silver/OD gold plated	
N	Nickel silver/no finish		
Termination	Letter	Description	A in (mm)
	M	Male round tube ①	
N	No termination		
S	Solder cup ②		
R*	Round pin	0.410 [10.41]	
R1*	Round pin	0.547 [13.89]	
R3*	Round pin	0.216 [5.49]	
R5*	Round pin	0.947 [24.05]	
W*	Square wire wrap pin	0.429 [10.90]	
W1*	Square wire wrap pin ①	0.694 [17.63]	
W2*	Square wire wrap pin ①	1.044 [26.52]	
W3*	Square wire wrap	0.164 [4.16]	
W5*	Square wire wrap pin ①	0.500 [12.70]	

NOTES: ① Not available in G Tube Material
* Pin material: Phosphor bronze/gold plated over nickel