



Workstations

C-LEG STATIONS

Item Numbers 1000-1570

PARTS AND HARDWARE	QUANTITY	
	30" D worksurface	36" D worksurface
Height Adjustable C-Legs (2 pieces each)	2	2
Frame	1	1
Worksurface Support Rails	2	3
Top Brackets	2	2
Worksurface	1	1
Leveling Feet	6	6
End Caps	8	8
Wood Screws	8	12
Tek Screws	6	8
Basic Nuts	8	10
Basic Bolts	12	14
7/32 Basic Allen Wrench (included)	1	1
Other Items Needed (not included)		
Phillips head screwdriver or drill		
Rubber Mallet		
Level		

Assembly Tips

- Review entire instruction manual before proceeding.
- Production Basics name plate indicates front of frame.
- Basic Nut grooves must grip inside of frame channel for support (see below).



- When initially securing Basic Bolts to Basic Nuts, attachment is easy when nut and bolt are turned only one revolution.
- Legs are adjustable in 2-inch increments between 30-36 OR 36-42 inches high to customize worksurface height.
- Don't be a slave to gravity—recruit a co-worker to help you install and correctly position components and accessories.
- References to 'Left' and 'Right' are oriented as if you were facing the front of the workstation.

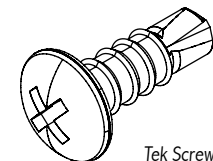
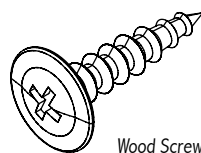
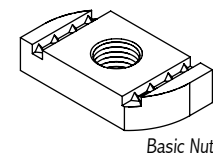
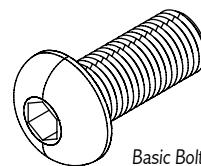

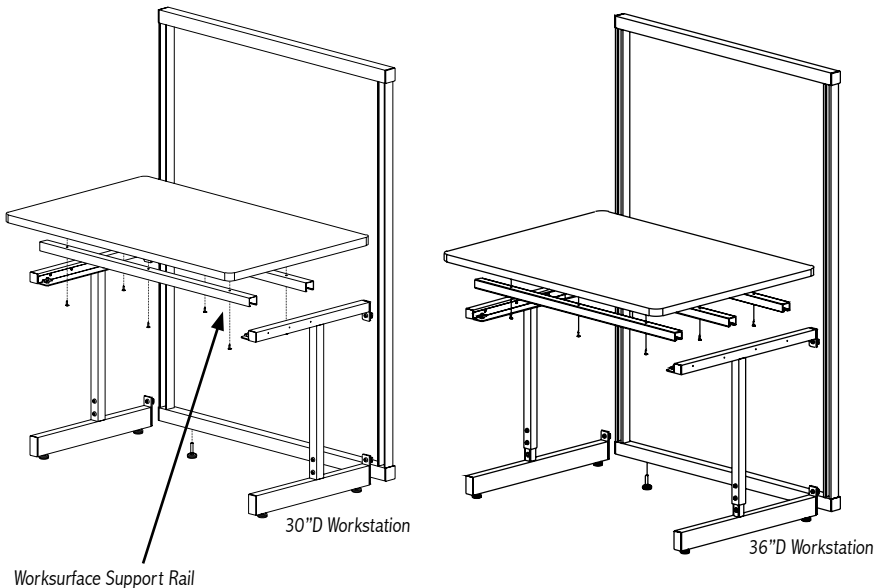
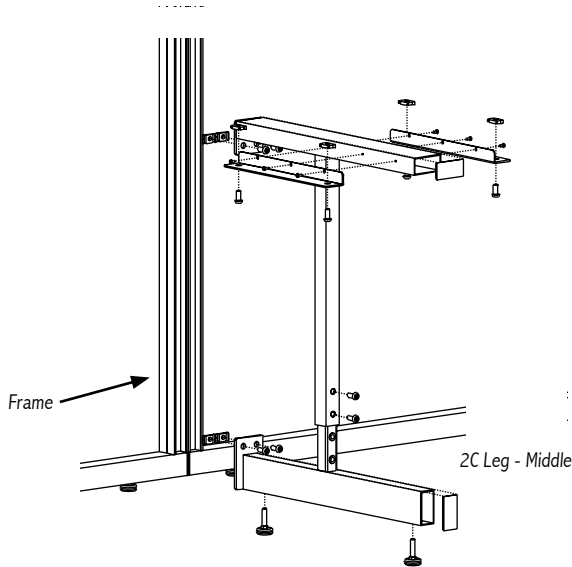
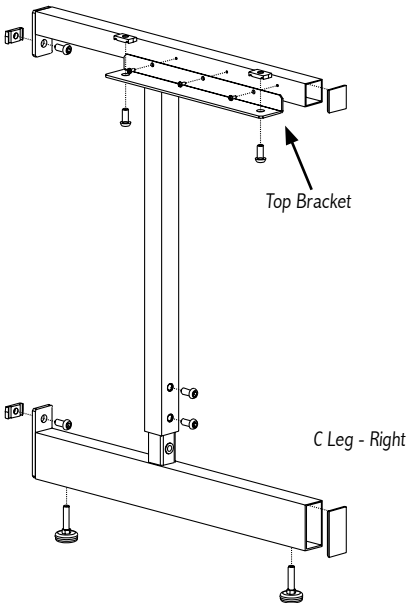

1. Insert two (2) Basic Bolts into pre-drilled holes determining height. Repeat for other C-Leg.
2. Insert bolts into each hole at back of leg. Secure with nut. Turn only one revolution. Repeat for other C-Leg.
3. Choose a leg for the right side of the station (as shown). Attach Top Bracket to the inside of the C-Leg with tek screws. This forms a shelf for the Worksurface Support Rails. Repeat for other C-Leg.
4. Insert Basic Bolt from bottom into holes on Top Bracket. Secure with nut. Turn only one revolution. Repeat for left C-Leg with opposite bracket, for left side of station.
 - a. If assembling Back-to-Back Stand Alone, Back-to-Back multiple, or Side-by-Side Stations prepare ALL C-Legs according to steps 1-4.
 - b. Quad and Side-by-Side Stations include one (1) 2C-Leg in place of two (2) C-Legs. Position the 2C-Leg in between adjacent stations (as shown).
5. Screw the Leveling Feet into bottom of C-Legs and Frame. Use rubber mallet to tap End Caps into frame and C-Legs.
 - a. For Side-by-Side Stations, end caps are not required where frames meet.
6. Lay Frame on a flat, level surface, channel side up.
 - a. For Side-by-Side Stations, lay Frames next to each other.
7. Insert Basic Nuts at back of leg into frame channel and turn Basic Bolt 90 degrees clockwise to grip (see *Assembly Tips* on page 1). Position C-Leg so that it is parallel to vertical channel and flush with bottom of frame. Tighten the bolts. Repeat with other C-Leg or 2C-Leg as applicable. Stand the station upright.
8. Place Worksurface Support Rails perpendicular to Top Brackets, channel side down, on top of nuts (as shown). Turn Basic Bolt 90 degrees clockwise to grip. Tighten the bolts. Repeat for both sides of station and all Worksurface Support Rails. 30"D C-Leg Stations will have two (2) Worksurface Support Rails; 36"D C-LEG Stations will have three (3).
9. Center the laminate worksurface on top of the Worksurface Support Rails with T-mold seam at the back. Ensure it is flush against the Frame. Attach the worksurface from underneath with wood screws.
 - a. If assembling Back-to-Back Stations, repeat steps 7-9 for the other side of the configuration.
10. Check all attachments and give all the bolts a final tightening.

STAND ALONE CORNER STATION

Item Numbers 1415, 1416, 1515, 1516

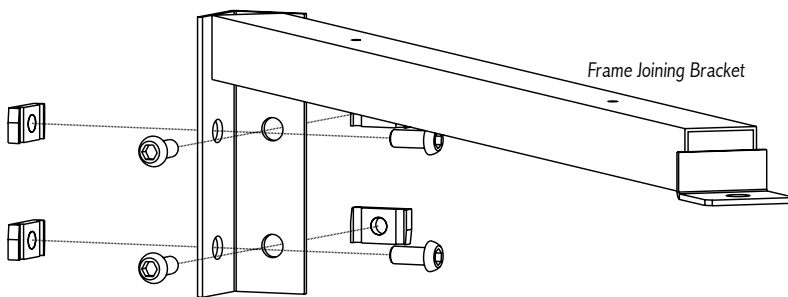
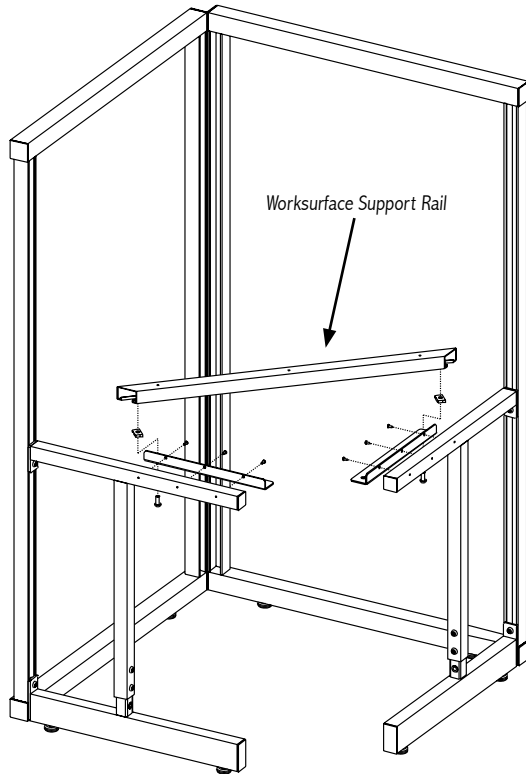

PARTS AND HARDWARE	QUANTITY
Frames	2
Height Adjustable C-Legs (2 pieces each)	2
Leveling Feet	8
Frame Joining Bracket	1
Worksurface Support Rail	1
Top Brackets	2
Laminate Worksurface	1
Basic Bolts	15
Basic Nuts	11
Wood screws	5
Tek screws	8
End Caps	12
Allen Wrench	1
Other Items Needed (not included)	
Phillips head drill or screwdriver	
Rubber mallet	
Level	

1. Prepare C-Legs as shown and described on page 2, steps 1 through 6.
2. Lay frames on a flat, level surface, channel side up.
3. Attach the C-Legs to the far left and far right of each frame (as shown). Insert Basic Nuts at back of leg into frame channel and turn Basic Bolt 90 degrees clockwise to grip. Position C-Leg so that it is perpendicular to frame and flush with bottom. Tighten the bolts. Repeat for other C-Leg.
4. Stand the frames upright. Position frames at a 90-degree angle, with the channel facing forward. Place Worksurface Support Rail, channel side down, on top of Basic Nuts attached to Top Brackets, above the rearmost hole position. Turn Basic Bolt 90 degrees clockwise to grip but do not fully tighten. Repeat for other side.
5. Insert a Basic Bolt into the four (4) mounting plate holes on the Frame Joining Bracket. Secure with Basic Nut. Turn only one revolution.
6. Attach Frame Joining Bracket, channel side down in between the Frames by inserting Basic Nuts into frame channel. Turn Basic Bolt 90 degrees clockwise to grip, but do not tighten.
7. Insert a Basic Bolt into the front tab of the Frame Joining Bracket from below. Secure with Basic Nut. Insert the nut into the worksurface Support Rail from below (as shown) and turn Basic Bolt 90 degrees clockwise to grip.
8. Use a level to make sure the Worksurface Support Rail and Frame Joining Bracket are positioned evenly. Bolts may need to be slightly loosened for alignment and re-tightened.

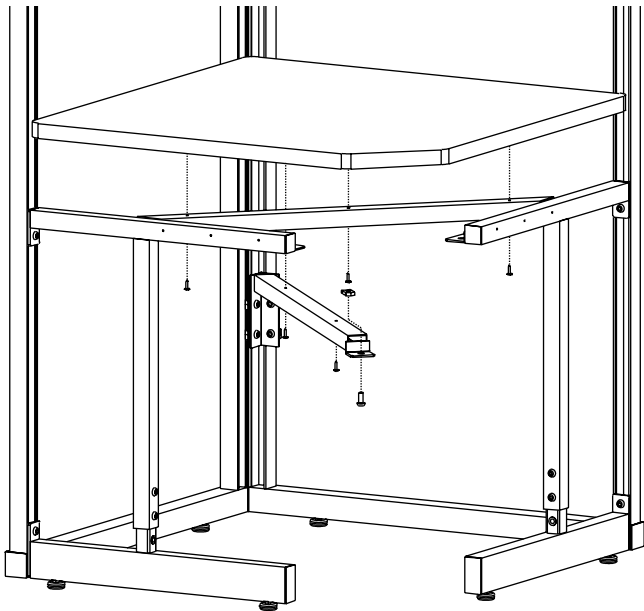

9. Place the laminate worksurface on top of the Worksurface Support Rail and ensure it is flush against the Frames and with the C-Legs on the sides. Face the seam of the T-mold edge toward the back. Attach the worksurface from underneath with wood screws.
10. Check all attachments and give all nuts and bolts a final tightening.

ADD-ON CORNER STATION

Item Numbers 1418, 1419, 1518, 1519

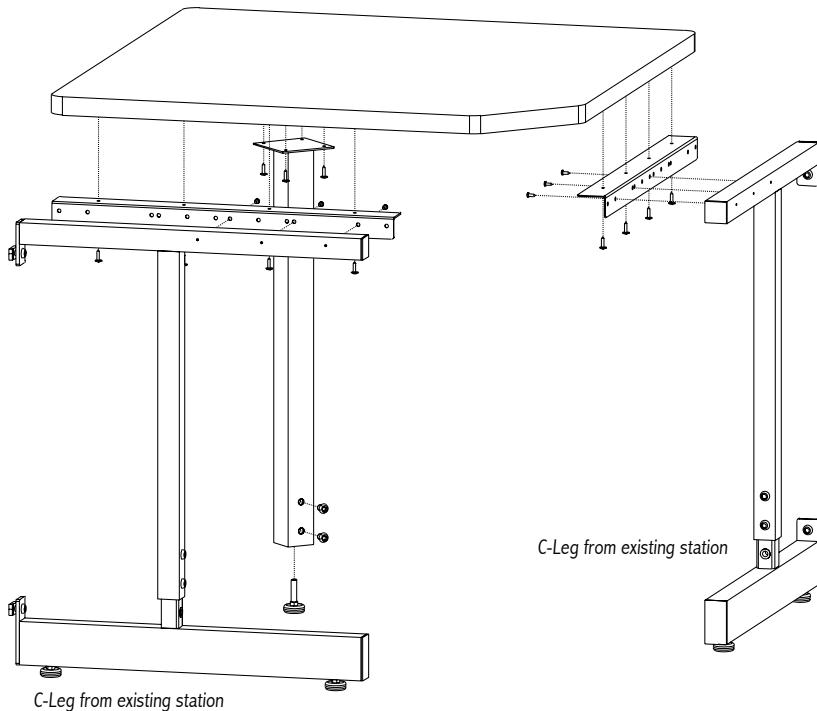

PARTS AND HARDWARE	QUANTITY
Height-Adjustable Leg (2 pieces each)	1
Leveling Foot	1
Top Brackets	2
Laminate Worksurface	1
Basic Bolts	2
Wood screws	12
Tek screws	6
Allen Wrench	1
Other Items Needed (not included)	
Phillips head drill or screwdriver	

• **Note: Add-on Corner requires two (2) Stand-Alone C-Leg Stations for proper assembly. Assemble C-Leg Stations before assembling Add-on Corner.**

1. Insert two (2) Basic Bolts into adjustable leg, determining height. Screw in leveling foot. Repeat for other C-Leg.
2. Insert three (3) tek Screws through pre-drilled holes in Top Bracket to outside of each existing C-Leg that joins the corner. The bracket should form a 2-inch shelf flush with the top of the C-Leg.
3. Place the corner laminate worksurface in between the workstations. Secure with wood screws through the Top Bracket.
4. Use wood screws to attach adjustable leg to underside of worksurface 1" from back edge.

GROUND BOLT

For ESD Laminate Worksurfaces and Shelving

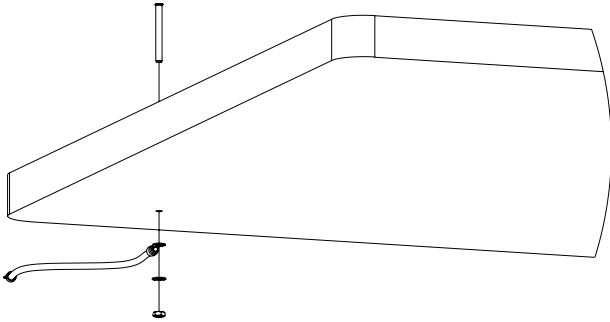

PARTS AND HARDWARE	QUANTITY
Ground Bolt	1
Ground Wire	1
Washer	2
Nut	1

1. Insert Ground Bolt through top of work surface through pre-drilled hole.
2. Slip ground wire over bolt underneath the work surface. Add the nut and tighten.
3. Ground other end of wire to electrical ground.
4. For additional information on grounding, contact your company's ESD manager or the ESD Association at 315.339.6937, www.esda.org.