

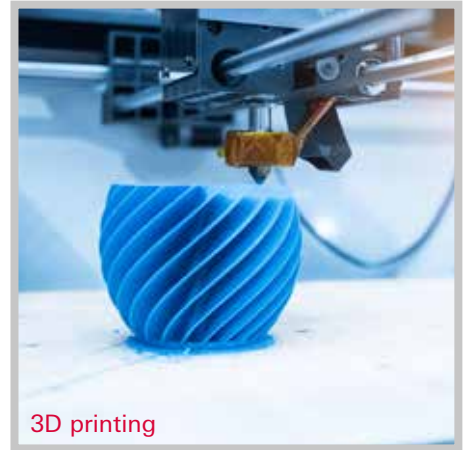

HiScroll®

The extremely quiet, efficient, oil-free pumps.
To reduce your CO₂ footprint.



3D printing



Mass spectrometry



Accelerators

HiScroll®

The extremely quiet, efficient, oil-free pumps. To reduce your CO₂ footprint.



HiScroll - the oil-free vacuum pumps

The HiScroll series consists of three dry scroll pumps with a nominal pumping speed of 6–21 m³/h, which are characterized by fast evacuation to atmosphere. Their powerful IPM¹⁾-synchronous motors with sensorless INFORM[®] control²⁾ achieve up to 15% higher efficiency than conventional drives and enable stable low operating temperatures for the pump. They also reduce electricity costs.

Its excellent vacuum performance, even with light gases such as helium, makes it the most preferred solution in the vacuum market for dry pumping solutions. The ability to equip the HiScroll with manual, permanently closed or fully automatic gas ballast optimizes the pump for individual customer applications. Adaptive fan control, intelligent pressure and speed control all ensure optimum cooling of the pumps and reduce energy consumption, wear and noise emissions.

HiScroll pumps can be easily connected via RS-485, ProfiNet or the standardized AccessLink ports to our Turbopumps. For the comfort and safety of our customers.

¹⁾ Interior permanent magnet

²⁾ INFORM[®] method according to Prof. Schrödl



Lowest operating costs



Safe operation



Explosion-proof ATEX design



Optimum process adaptation



Compact design

Lowest noise emission on the market

The HiScroll pumps are extremely quiet at <47 dB[A] (in stand-by mode <42 dB[A], 3-phase version <55 dB(A)). Thanks to their low-vibration operation and compact design, they are ideal for use in quiet and highly integrated working environments such as mass spectrometers, research institutes or leak detection systems.

High level of safety

To ensure safe operation, the hermetically sealed HiScroll is equipped with a non-return valve at the outlet as standard. The two-stage gas ballast valve ensures high water vapor compatibility and enables individual process adjustment of the pump.

The proven quality of Pfeiffer Vacuum components and the optional integrated pressure sensor both guarantee low operating costs, efficient process adjustment and a long service life. Pump maintenance is simple and enables short service times.

HiScroll®

Details and application examples

The 3-phase HiScroll 18 for harsh industrial environments

The robust HiScroll 18 pumps with 3-phase power supply connection and the Harting Han Q3/0 crimp connector system have been developed for use in demanding industrial environments. They now have improved protection class IP44 for protection against splashing water from all sides. Semiconductor components have also been significantly reduced for increased radiation protection.

ATEX certification:

HiScroll pumps are already certified to ATEX II 3/G Ex h IIC T4 Gc X +5°C ≤ Ta ≤ +40°C as standard³⁾.

Typical applications

- Mass spectrometry
- Accelerators
- laboratories
- Leak detection
- Semiconductor technology
- Coating technology
- Gas recovery
- Vacuum drying

³⁾ Only without optional electrical accessories such as the integrated pressure sensor



Exploded drawing

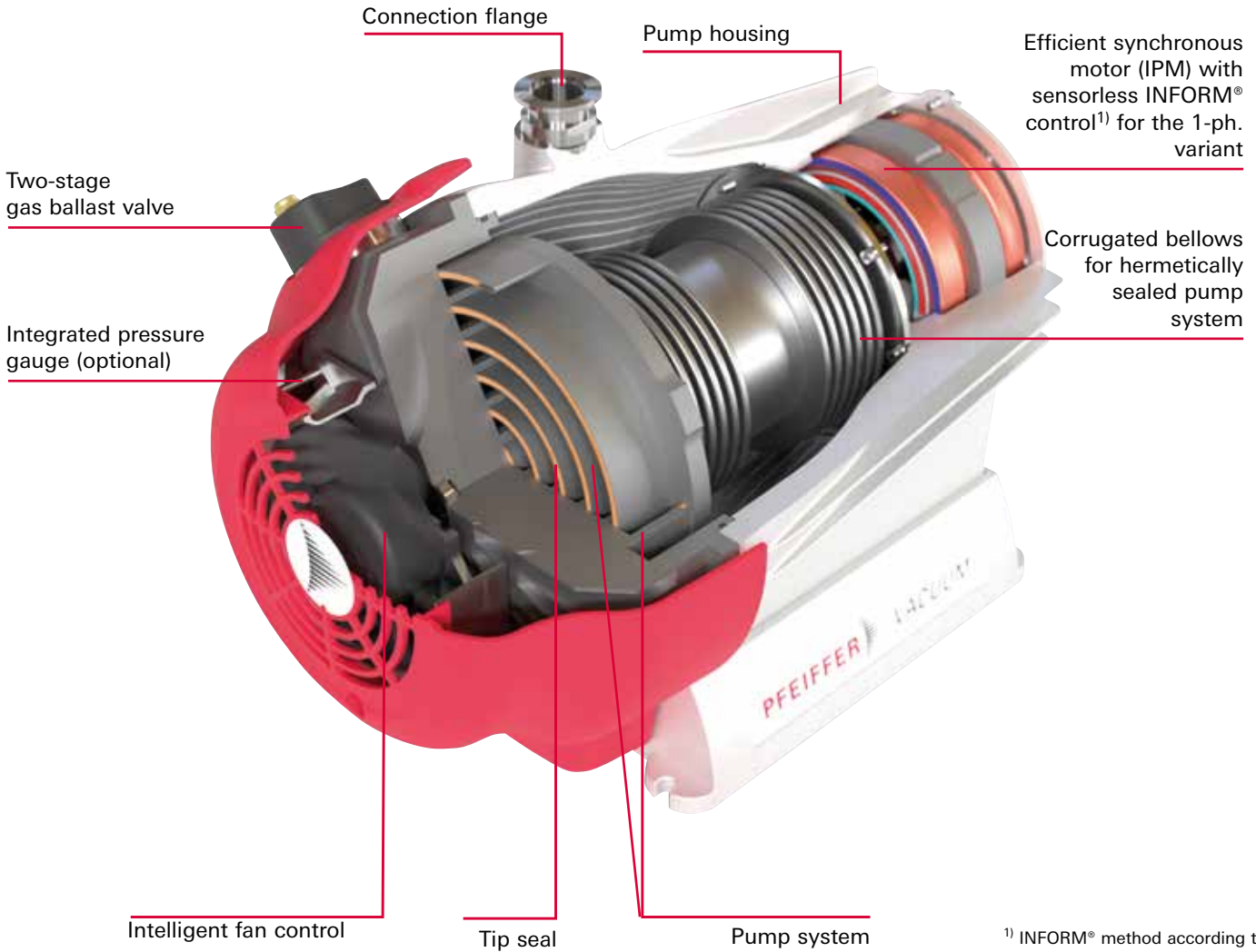

Details

Gas ballast available as: Manual, permanently closed or fully automatic.

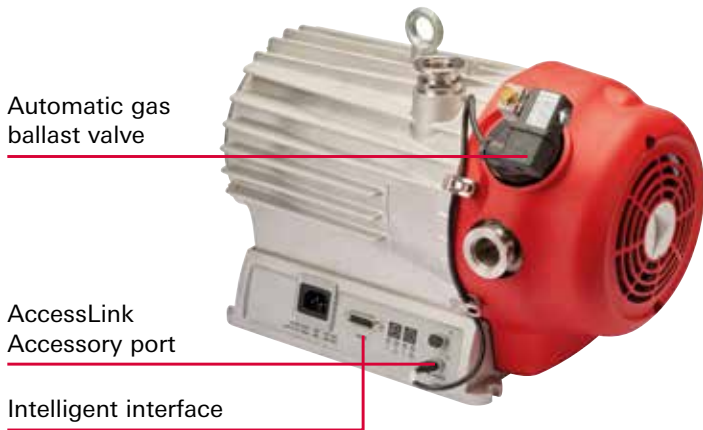

HiScroll 6, 1-phase

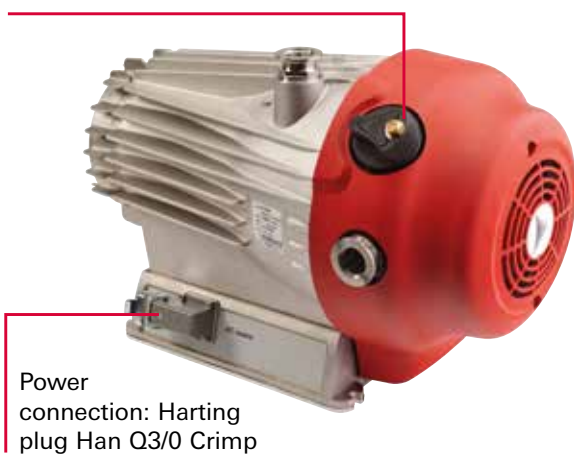

HiScroll 18, 3-phase

HiScroll®

The extremely quiet, efficient, oil-free pumps. To reduce your CO₂ footprint.

Best energy efficiency

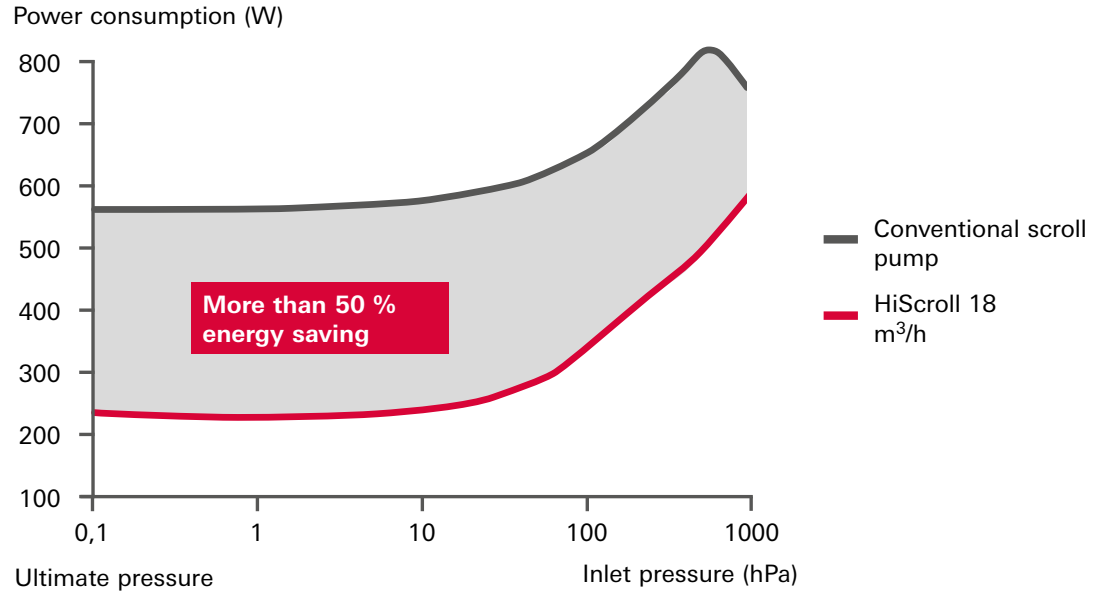

Constant pumping speed

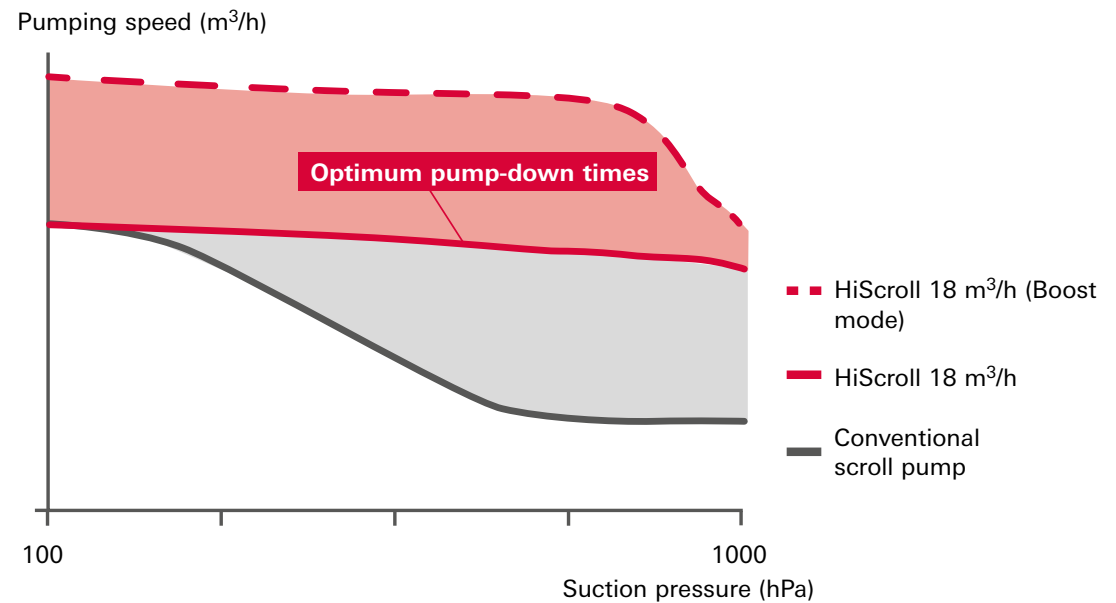

We drive Sustainable Solutions

Environmentally friendly

The use of innovative IPM¹⁾ synchronous motors in the HiScroll pumps significantly reduces their power consumption; despite their high pumping capacity. This not only results in lower operating costs for the user but the motor also achieves a premium level of efficiency and significantly exceeds the minimum values of efficiency class IE3; which apply to standard asynchronous motors. This also results in cooler and lower-wear operation and minimizes heat dissipation into the environment.

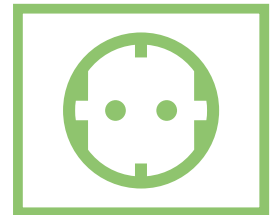

Conserving resources

Our HiScroll scores come right from the production stage, thanks to deliberate material savings. For example, the less copper that is used, advanced technologies make it possible to dispense with additional sensors. As well as the manufacture of housing parts using a casting process which reduces production waste.

Resources are also conserved during packaging: lightweight and space-saving insulating materials effectively protect our HiScroll from transport damage while also ensuring optimized weight.



Sustainable

Finally, both man and machine benefit equally from the use of modern technologies. HiScroll pumps generate less waste heat, have a long service life and operate quietly and with low vibration. As a result, they not only ensure a safe and comfortable working environment, but also reduce the cooling requirements of our customers' air conditioning systems in the area where our solutions are used.

¹⁾ Interior permanent magnet



HiScroll®

Suction capacity, dimensional drawings

Suction capacity

HiScroll 6

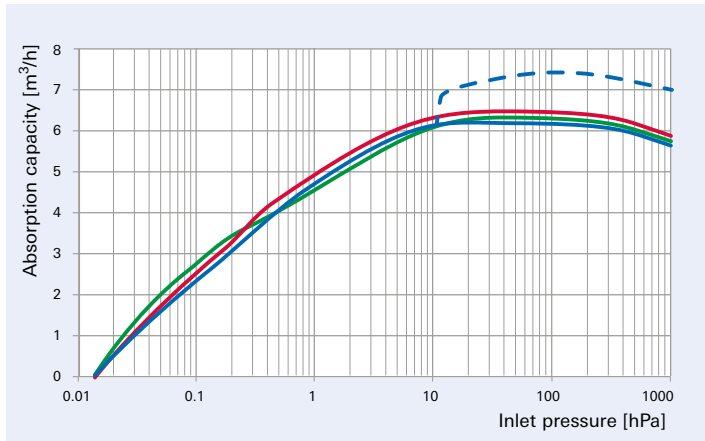

HiScroll 12

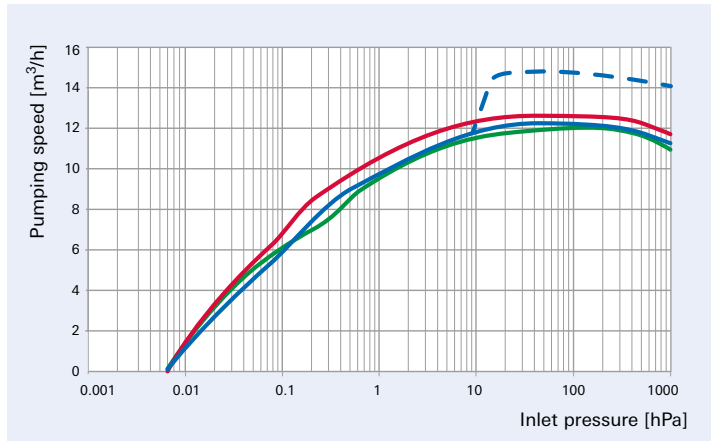

HiScroll 18

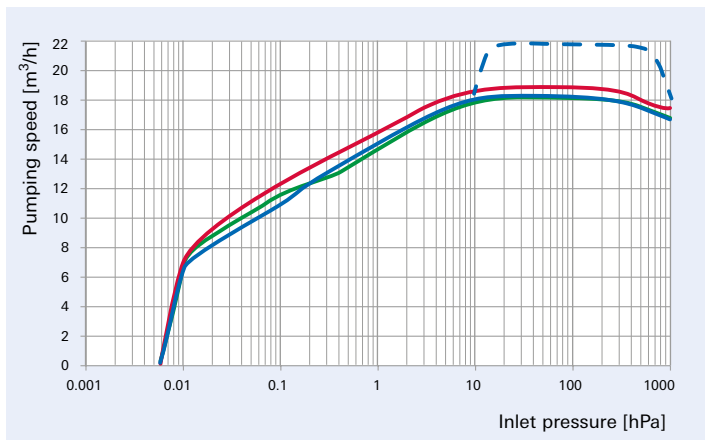

HiScroll 18, 3-phase, 50/60 Hz

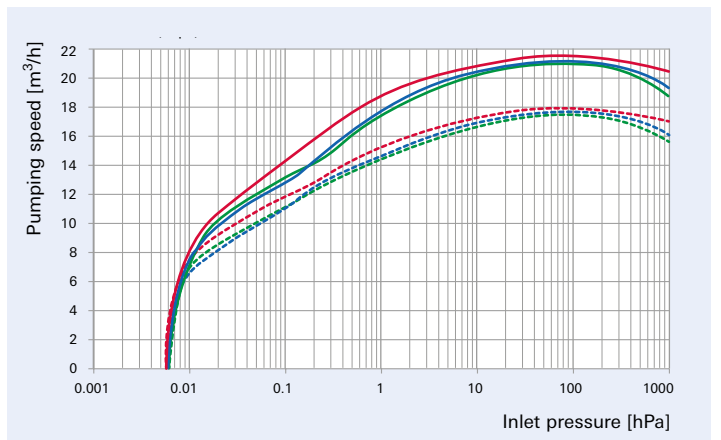

Boost mode - - -
 N₂ —
 Ar —
 He —

60 Hz N₂ — 50 Hz N₂ - - -
 Ar — Ar - - -
 He — He - - -



Dimension drawings

HiScroll 6

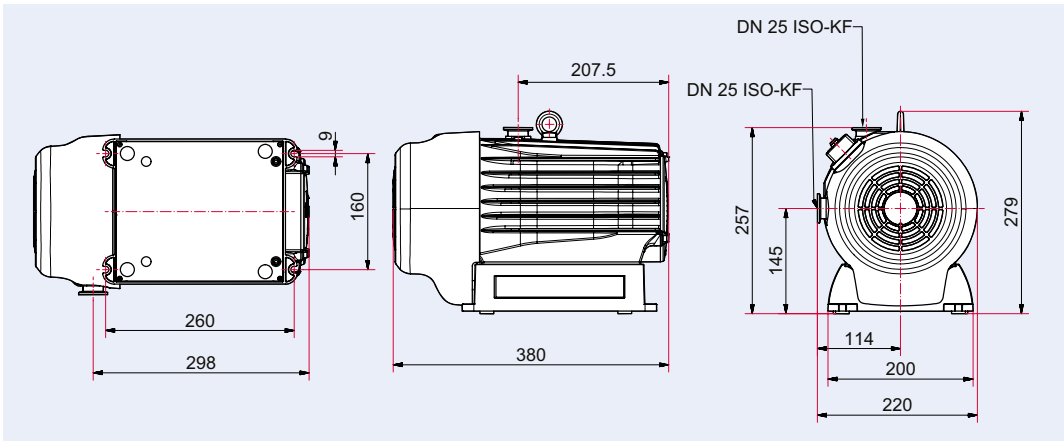

HiScroll 12 / HiScroll 18

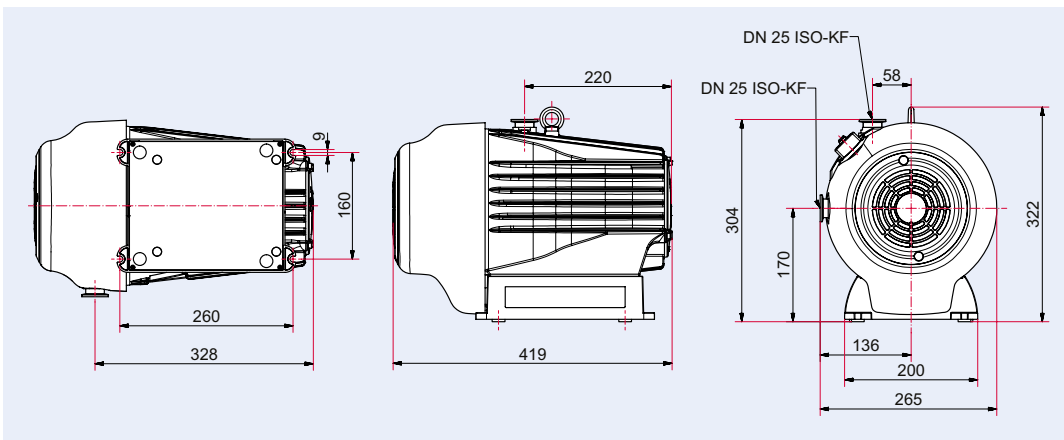

HiScroll 18, 3-phase

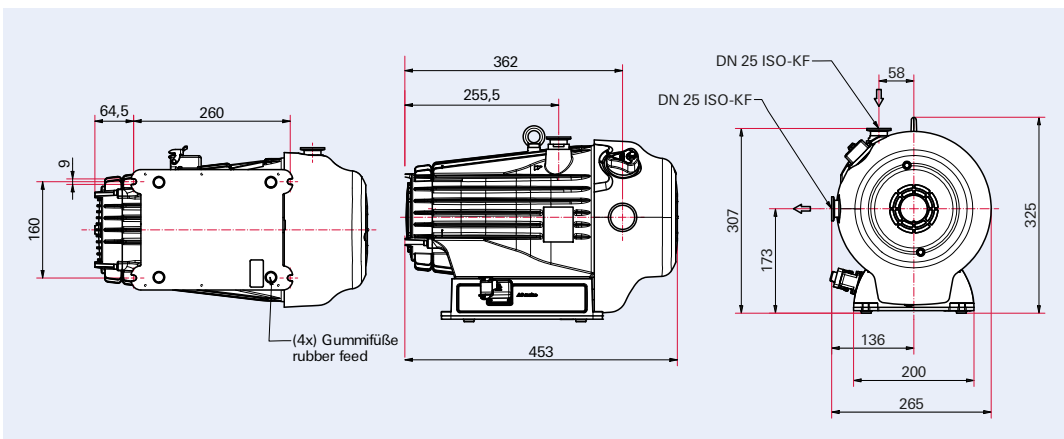

Dimensions in mm

HiScroll®

Technical data, order number matrix, accessories

Technical data

	HiScroll 6	HiScroll 12	HiScroll 18	HiScroll 18, 3 phase
Suction capacity	6.1 m ³ /h	12.1 m ³ /h	18.1 m ³ /h	17.2 / 21 m ³ /h
Tested base pressure ²⁾	1.5 · 10 ⁻² hPa	6 · 10 ⁻³ hPa	6 · 10 ⁻³ hPa	6 · 10 ⁻³ hPa
Ultimate pressure with gas ballast level 1 ¹⁾	7 · 10 ⁻² hPa	5 · 10 ⁻² hPa	3 · 10 ⁻² hPa	3 · 10 ⁻² hPa
Ultimate pressure at gas ballast level 2 ¹⁾	4 · 10 ⁻¹ hPa	4 · 10 ⁻¹ hPa	2 · 10 ⁻¹ hPa	2 · 10 ⁻¹ hPa
Gas ballast flow stage 1	11 l/min	18 l/min	23 l/min	23 l/min
Gas ballast flow stage 2	16 l/min	30 l/min	30 l/min	30 l/min
Leakage rate	5 · 10 ⁻⁷ Pa m ³ /s at 100 % helium Test gas			
Intake pressure, max.	1,100 hPa			
Exhaust pressure, max.	1,500 hPa			
Connection flanges (inlet/outlet)	DN 25 ISO-KF			
I/O interfaces	RS-485			
Mains connection	100–127/200–240 V AC (±10 %), 50/60 Hz			190–220V/380–415V (± 5%), 50Hz 200–240V/380–480V (± 5%), 60 Hz
Rotational speed min.	1,000–3,000 rpm	624–1,870 rpm	624–1,870 rpm	–
Rotational speed max.	2,500 rpm	1,560 rpm	1,560 rpm	1,460 rpm/50 Hz; 1,760 rpm/60 Hz
Protection class	IP40			IP44
ATEX certifications	Ex II 3/-G Ex h IIC T4 Gc X +5 °C ≤ Ta ≤ +40 °C			
Max. operating altitude	3,000 m			
Ambient temperature	5–40 °C			
Cooling type	Air, forced convection			
Emission sound pressure level (EN ISO 2151)	48 dB(A)	47 dB(A)	47 dB(A)	55 dB(A)
Weight	19 kg	24 kg	23 kg	27 kg
Gas ballast	manual, permanently closed or fully automatic			manual or permanently closed

¹⁾ The final pressure is usually reached after a certain running time. The running-in process can be accelerated by using gas ballast and / or nitrogen.

²⁾ Tested base pressure during quality control before dispatch in accordance with ISO 21360. Quality control is carried out using a calibrated pressure gauge that is independent of the gas type.



Order number matrix HiScroll

Size	a
HiScroll 6	1
HiScroll 12	2
HiScroll 18	3
Drive	b
1-phase motor	0
3-phase motor ¹⁾	2
Equipment	c
Standard, ATEX certified ¹⁾	0
Integrated pressure sensor RPT010	1
Gas ballast	d
Manual gas ballast ¹⁾	0
Gas ballast permanently closed ¹⁾	1
Automatic gas ballast valve ²⁾	2

PD Sa0 bcd

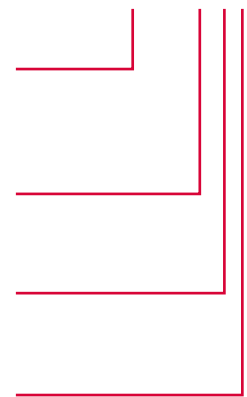

¹⁾ Only for HiScroll 18, without frequency inverter & PV AccessLink

²⁾ ATEX certification is not possible if the automatic gas ballast valve is selected

Accessories

	Order number
Accessory cable	
Mains cable with Harting plug for HiScroll 3-phase, 3 m long, Han Q3/0-f-crimp on open strands (3 phases, 1 PE)	PE 100 399 -U
Mains cable 230 V AC, CEE 7/7 to C13, 3 m	P 4564 309 ZA
Mains cable 115 V AC, NEMA 5-15 to C13, 3 m	P 4564 309 ZL
Interface cable M12 m straight/M12 m, straight,	PM 061 283 -T
USB RS-485 converter	PM 061 207 -T
Adapter, RS-485 M12	PE 100 150 -X
Y-distributor M12 for RS-485	P 4723 010
Connecting cable HiScroll / HiPace / TC 400, 3 m	PM 071 732 -T
Connecting cable HiScroll / HiPace / TC 110 / TPS, 3 m	PM 071 733 -T
Remote controller	
Converter Kit EtherCAT	PE 300 310 -T
Converter Kit Profinet	PE 300 300 -T
OmniControl 001, rack device without integrated power supply unit	PE D42 100 0
HPU 001, Handheld Programming Unit	PM 051 510 -T
Sensors	
RPT 010 pressure sensor, digital piezo/Pirani sensor	PD 100 100 AT
Filter	
SAS 25 S, dust separator with polyester filter insert	PK Z60 507
Silencer	
ES 25 M, external HiScroll silencer	PD Z10 000
ES 25 L, External silencer HiScroll	PD Z10 001
Components	
Push-in fitting G 1/8" including seal for hose connection (8/6 mm)	P 4131 029
Cover cap for gas ballast valve	PD 100 067
Valves	
Vacuum safety valve HiScroll 12/18	PD Z10 051 in conjunction with 115902 (Both items must be purchased together!)
Vacuum safety valve HiScroll 6	PD Z10 050
Automatic gas ballast valve	PD Z10 100
Spare parts packages	
Maintenance Kit Level 1, TipSeal Kit, HiScroll 6	PD E10 000 -T
Maintenance Kit Level 1, TipSeal Kit, HiScroll 12/18	PD E20 000 -T
O-ring lifter	PV A00 778

Tip:

Spare parts packages

With the original Pfeiffer Vacuum spare parts packages and the appropriate tools, you can change the tip seal of your HiScroll yourself in approx. 15 minutes





HiScroll with mounted automatic gas ballast valve

You can find further accessories on our website at www.pfeiffer-vacuum.com

Your Success. Our Passion.

We give our best for you every day –
worldwide!

**Are you looking for an
optimal vacuum solution?**
Please contact us:

Pfeiffer Vacuum GmbH
Germany
T +49 6441 802-0



Errors excepted. All data subject to change without prior notice. PU 0066 PEN (August 2024/PoD)

Follow us on social media
#pfeiffervacuum



www.pfeiffer-vacuum.com

PFEIFFER  **VACUUM**