



HiScroll 12, scroll pump, standard, including ATEX





HiScroll 12, scroll pump, standard, including ATEX

- No hydrocarbons: Completely dry & oil-free Scroll vacuum pump
- Low noise level, minimal vibrations and compact design, ideal also for use in laboratories
- Safe operation due to the installed non-return valve and hermetically sealed pumping system
- Low operating costs thanks to the highest quality, short maintenance times and long maintenance intervals
- Power as required: Stable pumping speed and short cycle times
- Sustainable: 15 % higher efficiency of the drive system, lower heat generation and lower cooling requirements
- Intelligent operating modes such as standby mode and interfaces for linking controllers and other Pfeiffer vacuum via RS-485
- Simple logistics: Our HiScroll pumps are suitable for all voltages worldwide

Characteristics

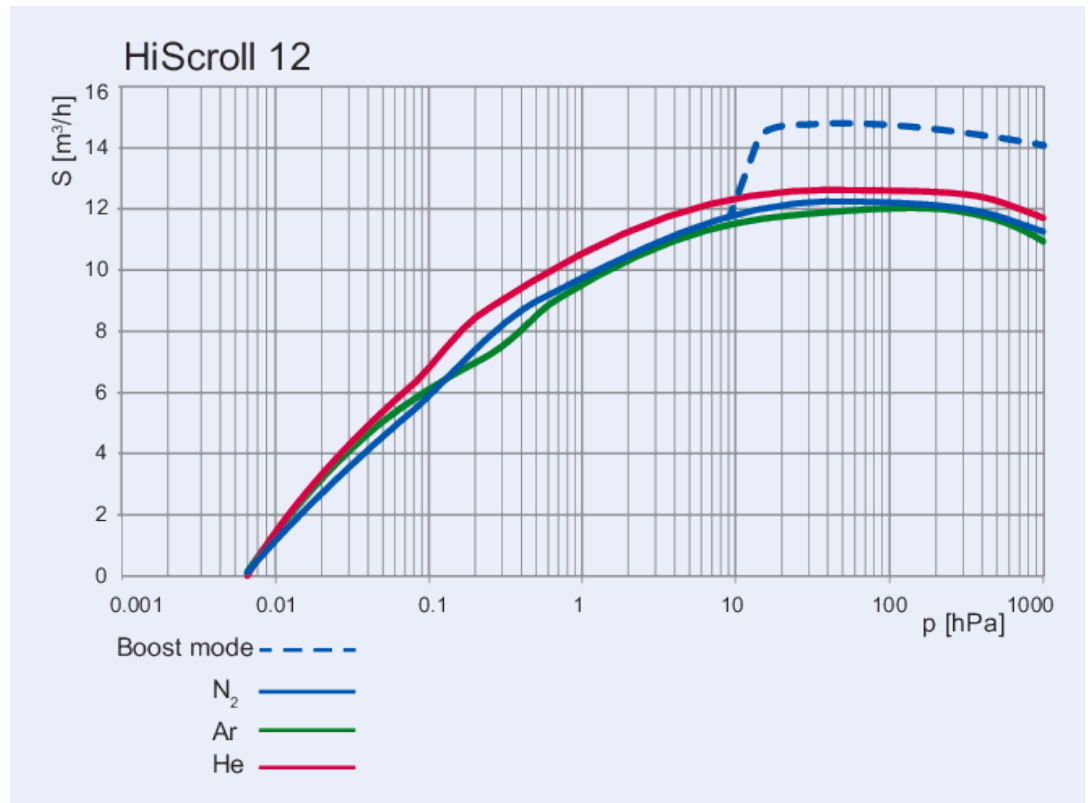

Dimensions

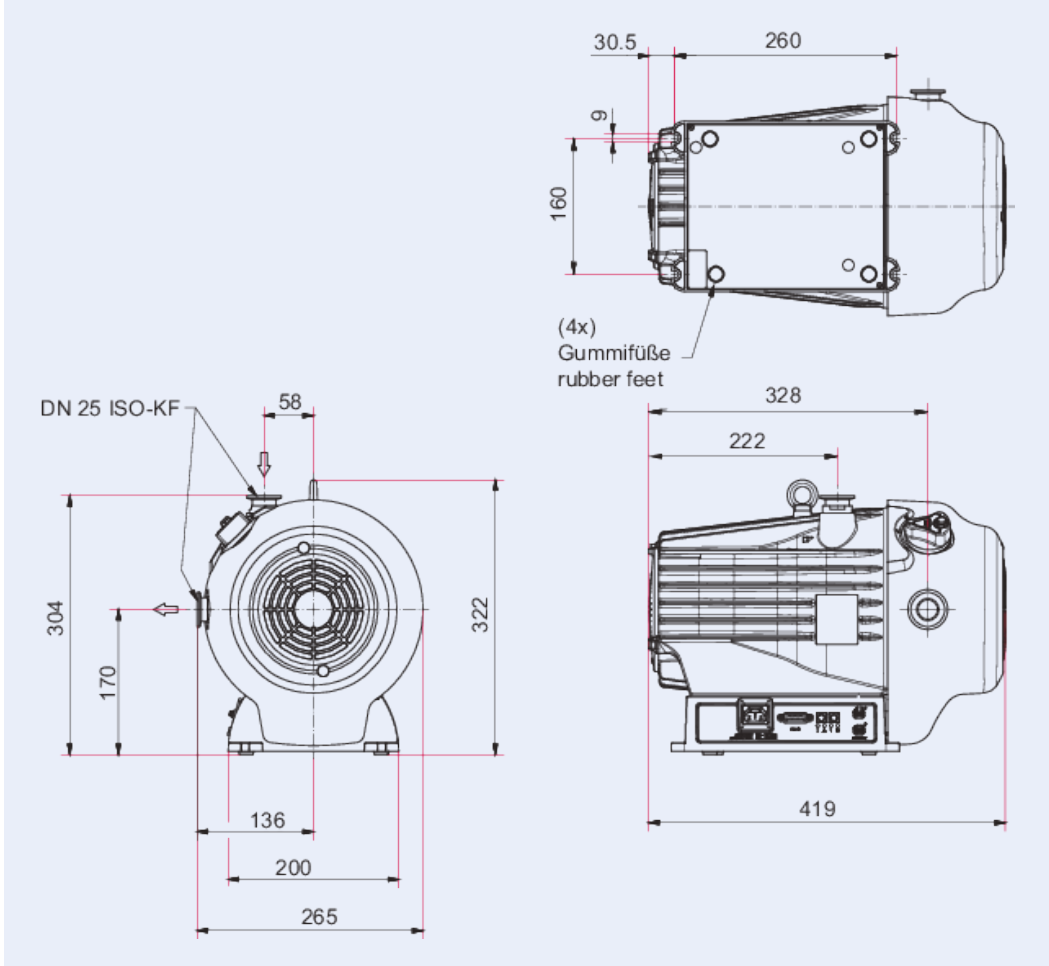

Technical Data	HiScroll 12, scroll pump, standard, including ATEX
Pumping speed	12.1 m ³ /h
Final pressure	6 · 10 ⁻³ hPa 4.5 · 10 ⁻³ Torr 6 · 10 ⁻³ mbar
Ultimate pressure for gas ballast stage 1	5 · 10 ⁻² hPa 3.75 · 10 ⁻² Torr 5 · 10 ⁻² mbar
Ultimate pressure for gas ballast stage 2	4 · 10 ⁻¹ hPa 3 · 10 ⁻¹ Torr 4 · 10 ⁻¹ mbar
Gas ballast flow stage 1	1.08 m ³ /h 0.636 cfm 18 l/min
Gas ballast flow stage 2	1.8 m ³ /h 1.059 cfm 30 l/min
Integral leak rate	5 · 10 ⁻⁷ Pa m ³ /s 6.65 · 10 ⁻⁵ Torr l/s 5 · 10 ⁻⁵ mbar l/s
Intake pressure max.	1,100 hPa
Exhaust pressure, max.	1,500 hPa 1,125 Torr 1,500 mbar
Connection flange (in)	DN 25 ISO-KF
Connection flange (out)	DN 25 ISO-KF
I/O interfaces	RS-485
Input voltage(s)	100 – 127 / 200 – 240 V AC (±10 %), 50/60 Hz
Input voltage: tolerance	±10 %
Rated current consumption	100 V – 127 V: 8 A 200 V – 240 V: 4 A
Current, max.	8 A
Rotation speed	624 – 1 870 rpm
Nominal rotation speed	1,560 rpm 1,560 min ⁻¹
Protection degree	IP40 Type 1
ATEX-certification	Ex II 3/G Ex h IIC T4 Gc X +5 °C ≤ T _a ≤ +40 °C
Certification	Semi S2 compatible Semi S8 compatible cTUVus certified according to UL / CSA 61010-1 KC
Switch	Yes
Ambient temperature	5 – 40 °C
Cooling method	Air (Forced convection)
Emission sound pressure level (EN ISO 2151)	47 dB(A)
Weight	24 kg 52.91 lb
Gas ballast	Yes
Operating altitude, max.	2,500 m

Order number	HiScroll 12, scroll pump, standard, including ATEX
HiScroll 12, scroll pump, standard, including ATEX	PD S20 000

Accessories	HiScroll 12, scroll pump, standard, including ATEX
Valve kit for HiScroll 6/12/18	PD E13 000 -T
Maintenance kit tip seal for HiScroll 12/18	PD E20 000 -T
Spare parts kit – Cover + fan for HiScroll 12/18	PD E25 000 -T

Your Success. Our Passion.

We give our best for you every day –
worldwide!

Are you looking for an optimum vacuum solution?

Talk to us:
Pfeiffer Vacuum GmbH
Germany
T +49 6441 802-0

Or scan the barcode, to visit our web page:



<https://webportal.pfeiffer-vacuum.com/global/en/contact>



Errors and/or changes excepted. - 7/6/2024

Follow Us On Social Media
#pfeiffervacuum



PFEIFFER  **VACUUM**

www.pfeiffer-vacuum.com