

PCE Instruments

ADVANCED PRECISION INSTRUMENT

SJX SERIES USER'S MANUAL

SJX Series
User Manual

ELECTRIC STAND

For

SJX-500V

SJX-500H

SJX-1KV

SJX-1KVL

SJX-2KV

SJX-5KV

SJX-10KV

SJX-20KV

SJX-30KV

Thanks for your purchasing SJX Series Electric Test Stand.
SJX Series Test Stand is specially applied for SN/SKN/SH/SP Series Force Gauge for tension and compression test. It owns presetting speed, wide application range, advantage of non-polar speed adjustment, manual or automatic operation, suitable for fields of rubber & plastic, textile, construction, complex material, wires & cables, auto accessories, engine and scientific research, etc. It can connect with computer, when applying with SH/SP series force gauge, you can control the test stand moving up or down by software. The SH/SP force gauge also can preset the stop force, when the force arrived the preset one, the test stand will auto stop.

Contents

Parameter.....	2
Outside Structure.....	3
Brief Introduction of Operating Panel.....	10
Panel Introduction.....	11
Attention.....	11
Operation Example.....	12
Packing List.....	14

Parameter

Model	SJX-500H	SJX-500V		SJX-1KV		SJX-1KVL	SJX-2KV	SJX-5KV	SJX-10KV	SJX-20KV	SJX-30KV
Test speed	50-500	50-245	250-500	50-245	250-500	50-500	50-500	30-240	20-120	20-120	8-75
Capacity	500	200	500	500	1000	1000	2000	5000	10000	20000	30000
Stroke	210	250		520		1000	600	200	200	200	200
Speed Accuracy	±10%										
Speed Resolution	5mm/min						1, 2, 3mm/min				
Max. Cycle times	1000										
Rated Voltage	Single-phase 220V										
Rated Current	1.5A										
Main Circuit Fuse	3A										
Work Temperature	20±10°C										
Storage and Transportation Temperature	-5°C ~ +40°C										
Relative Humidity	15% ~ 80%RH										

Outside Structure

1. SJX-500V Outside Structure

Unit: mm

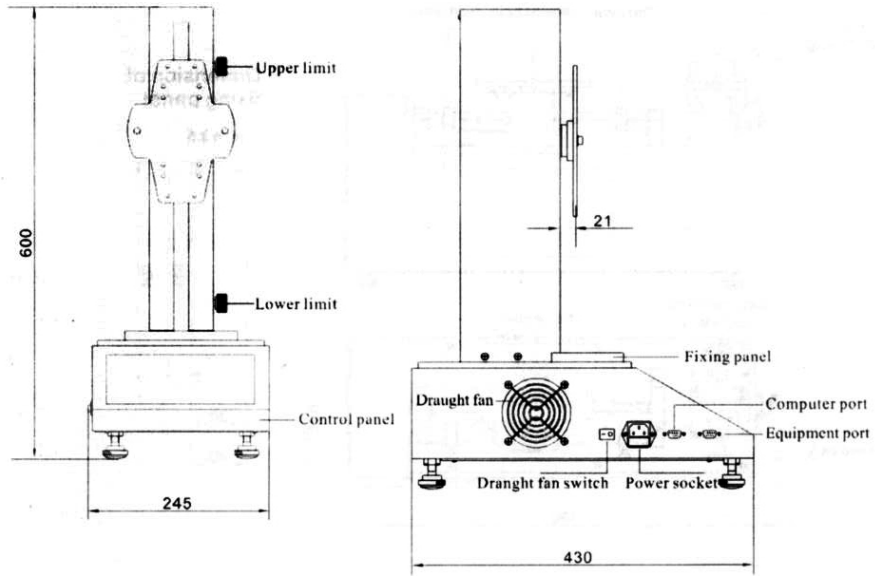

Dimension Of Fixing Panel

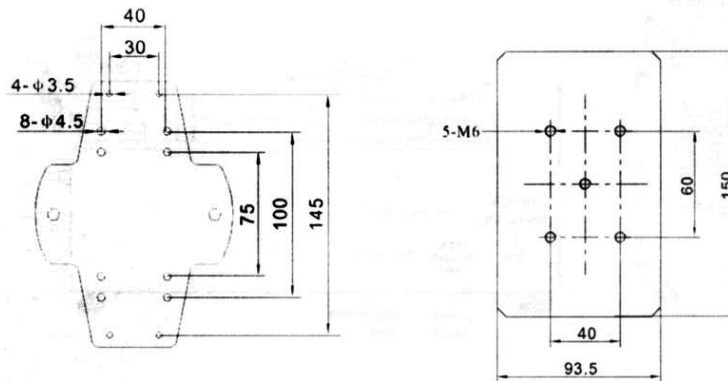

Picture I-1

Note: Applied with (purchase additionally): SN/SH/SP (sensor inside) force gauge.

2、SJX-500H Outside Structure

Unit: mm

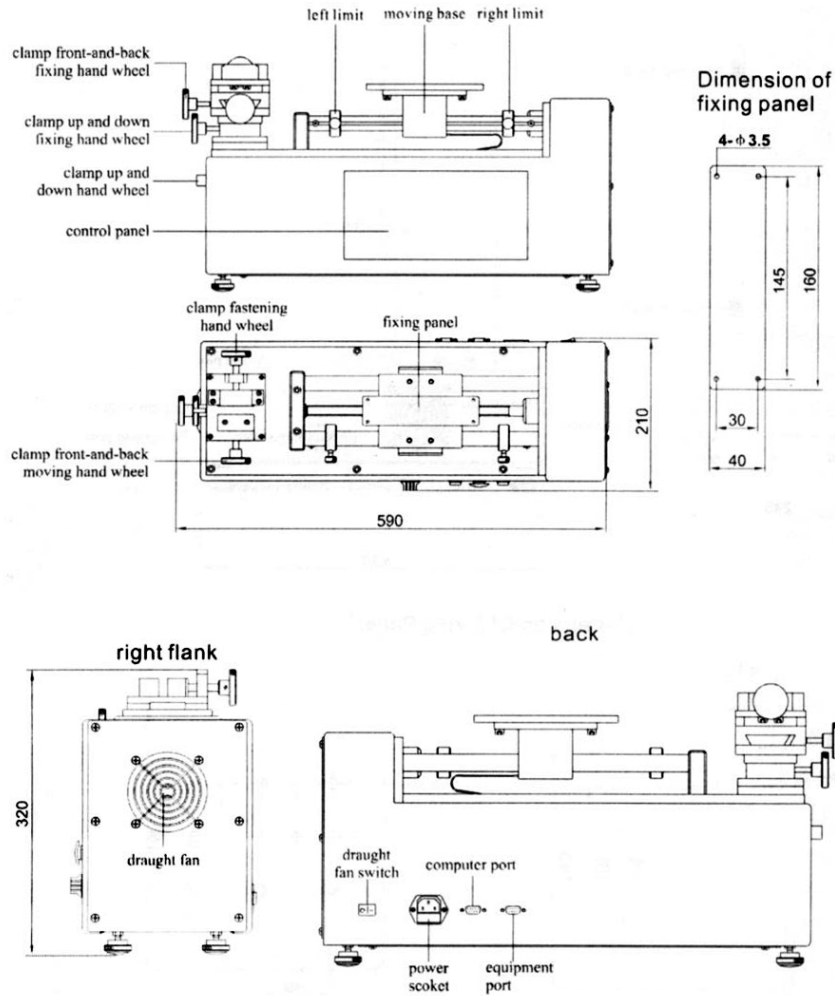

Picture1-2

Note: Applied with (purchase additionally): SN/SH/SP (sensor inside) force gauge.

3、SJX-1KV Outside Structure

Unit: mm

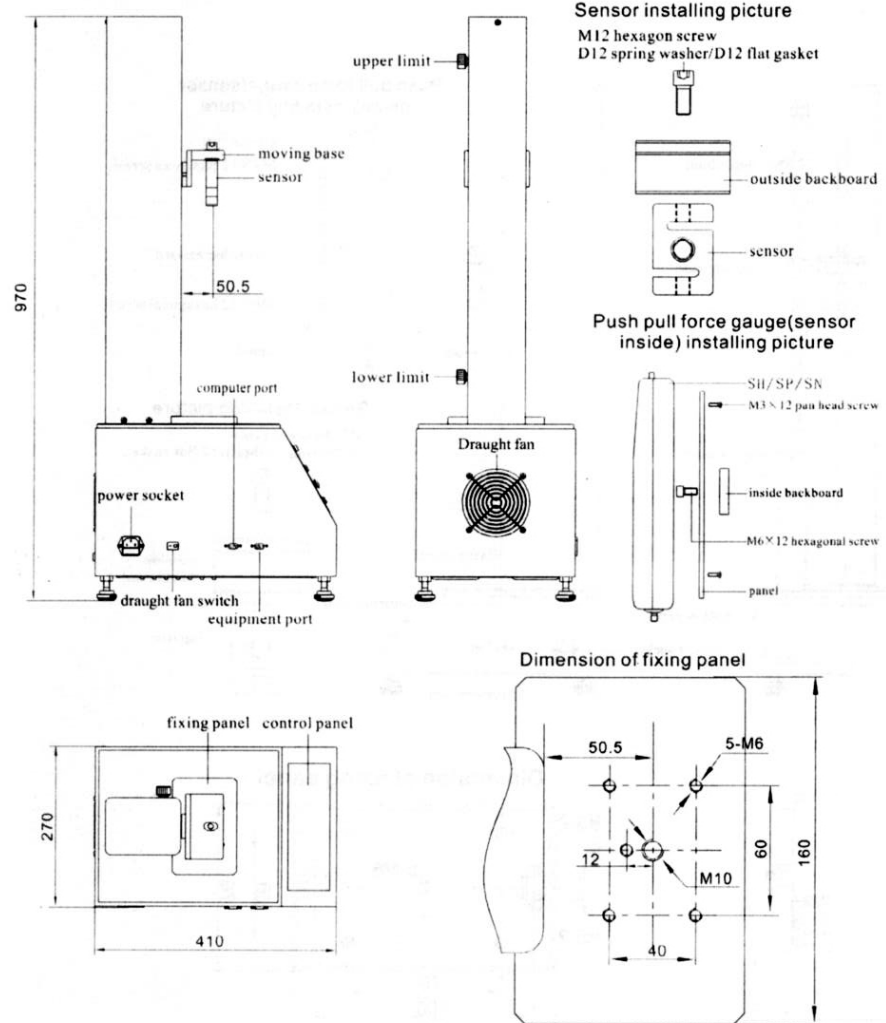

Picture1-3

Note: Applied with(purchase additionally)SN,SH/SP(within 1000N)force gauge;
 Different force gauge is applied with different backboard.

4、SJX-1KVL Outside Structure

Unit: mm

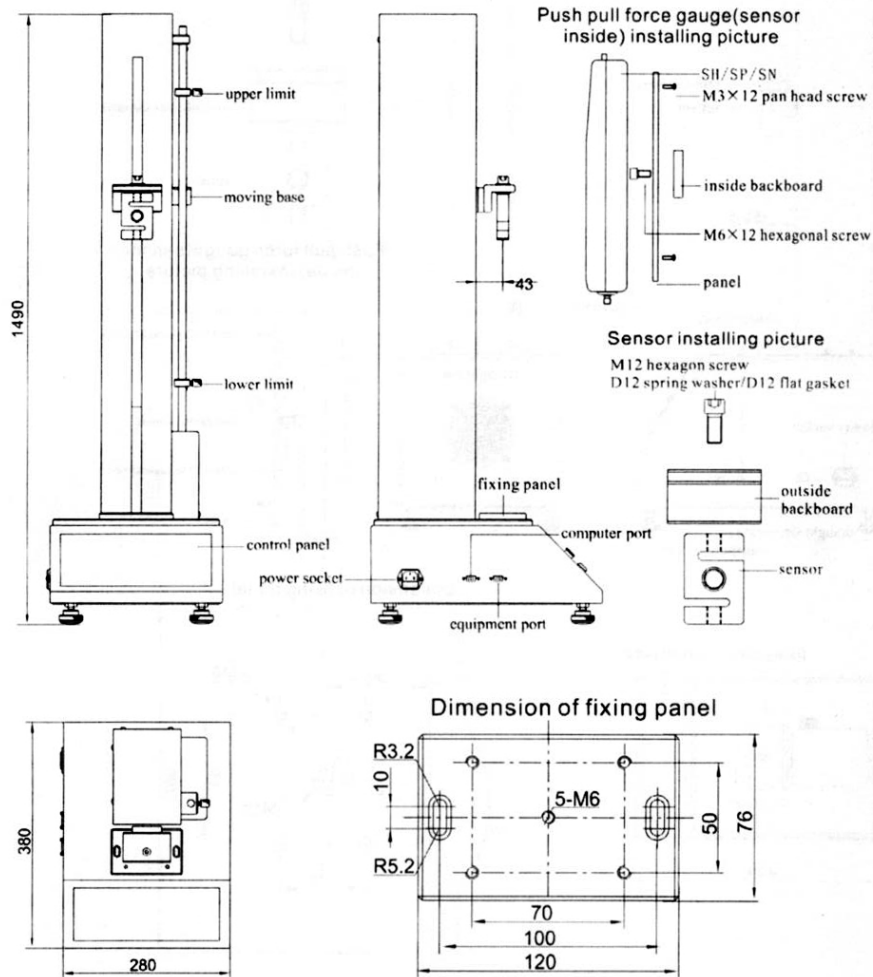

Picture 1-4

Note: Applied with (purchase additionally) SN, SH/SP (within 1000N) force gauge; Different force gauge is applied with different backboard.

5、SJX-2KV Outside Structure

Unit: mm

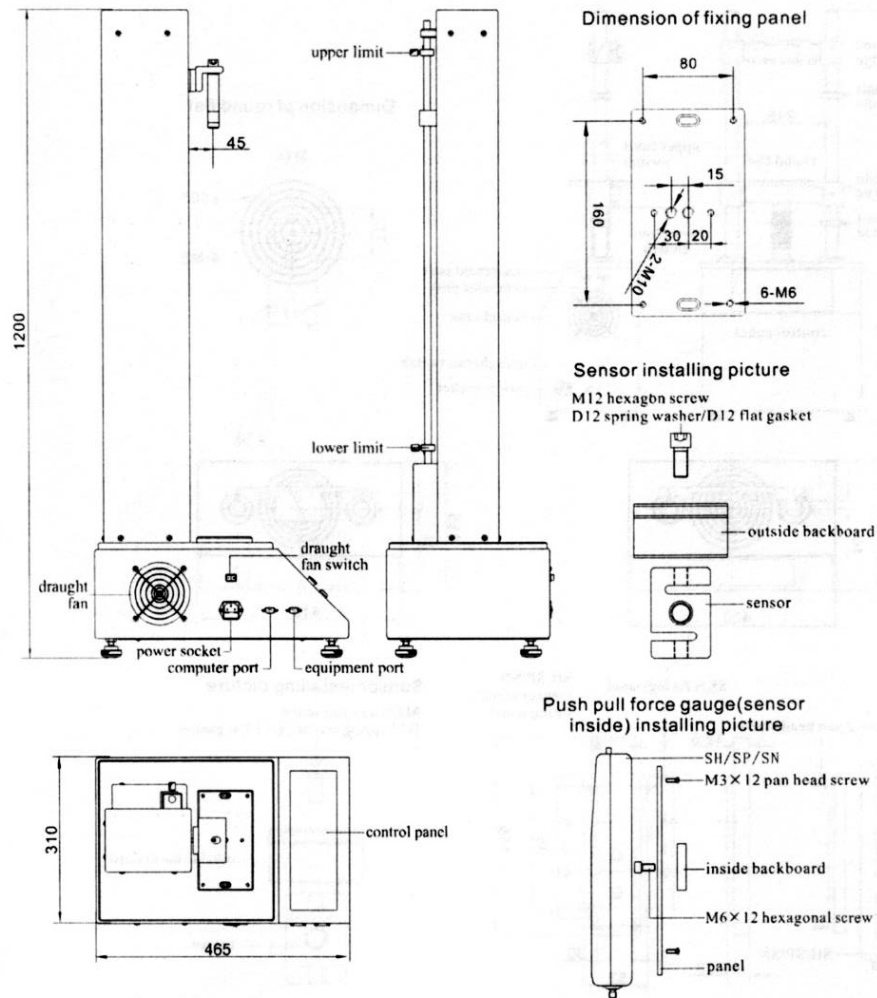

Picture1-5

Note: Applied with (purchase additionally) SN, SH/SP (within 2kN) force gauge;
 Different force gauge is applied with different backboard.

6、SJX-5KV/10KV Outside Structure

Unit: mm

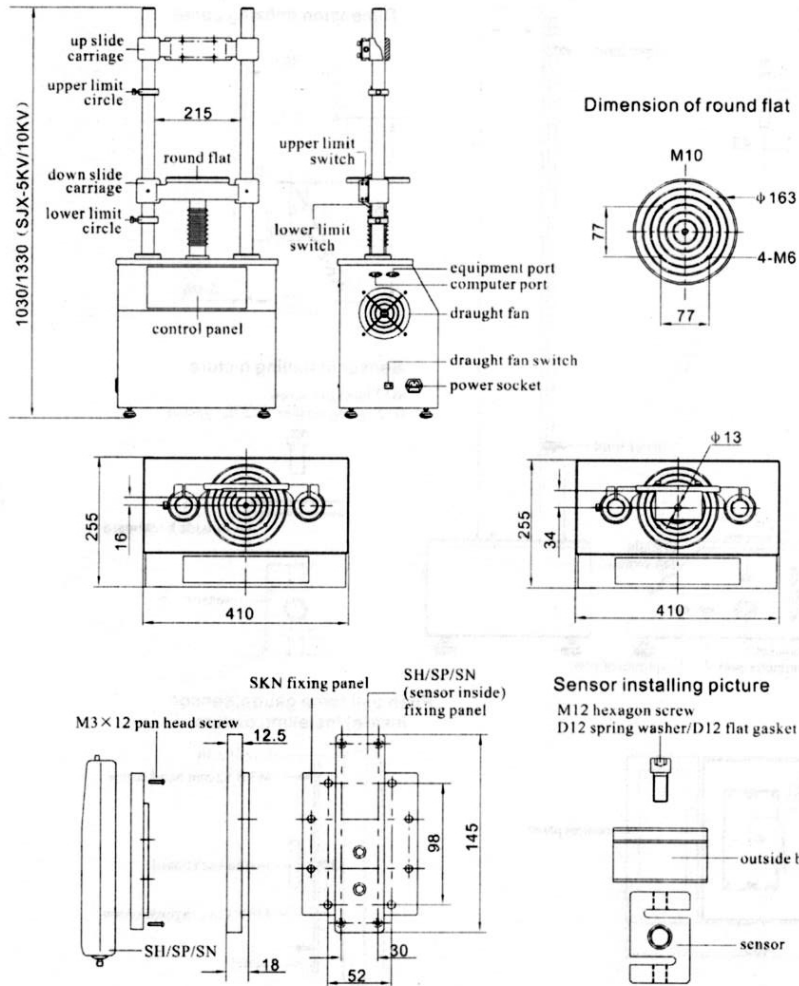

Picture 1-6

Note: Applied with (purchase additionally) SN, SKN, SH/SP (within 5KN) force gauge. Different force gauge is applied with different backboard.

7、SJX-20KV/30KV Outside Structure

Unit: mm

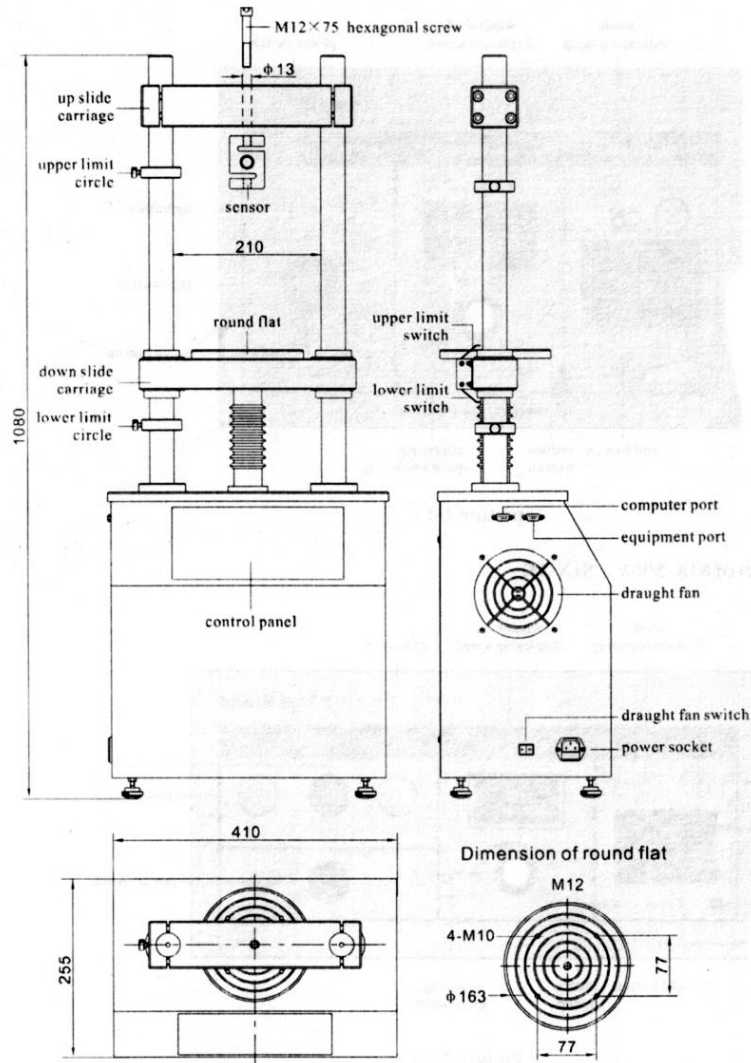

Picture 1-7

Note: Applied with (purchase additionally) SH/SP (1kN-30kN) force gauge.

Brief Introduction Of Operating Panel

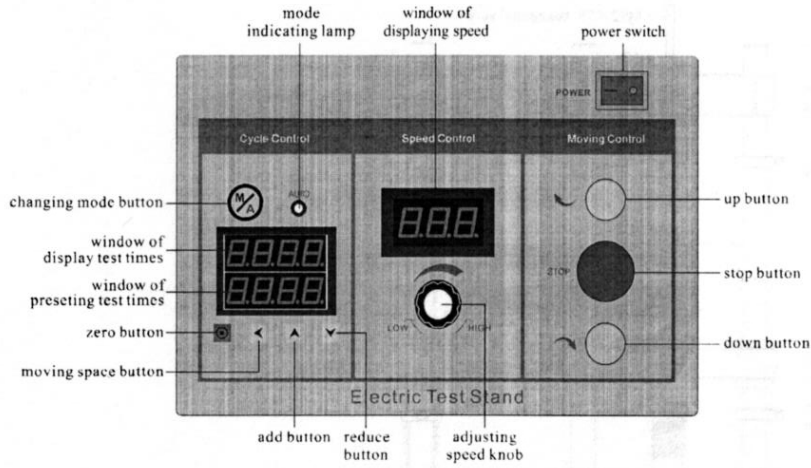

(picture 2-1)

Operating panel of SJX-500V、SJX-1K

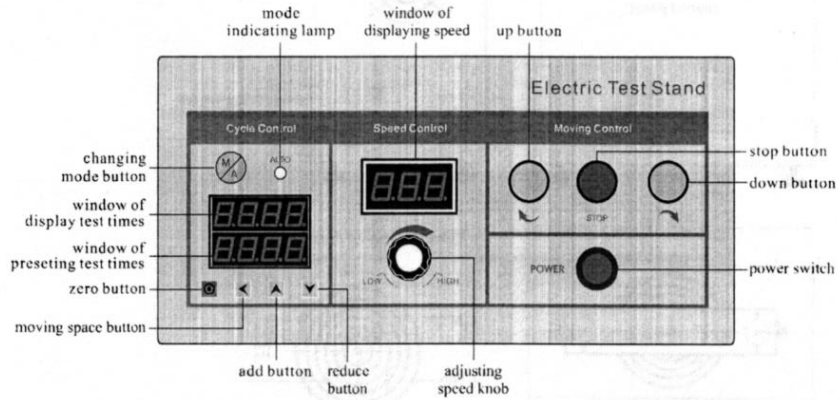

(Picture 2-2)

Operating panel of SJX-500H、SJX-1KVL、
SJX-2KV、SJX-5KV、SJX-10KV、SJX-20KV、SJX-30KV

Panel Introduction

Power key: control the whole machine's power on and off.

Up key: the button shines when up (or left move), turn off when stop.

Down key: the button shines when down (or right move), turn off when stop

Stop key: stop movement.

Speed adjusting key: adjust the moving speed.

Speed display window: display the setting moving speed at the present time.

Mode shift: shift test mode, shift during the test mode A (cycle) and M (manual)

Mode state pilot lamp: light on is test mode A(cycle); light off is test mode M (manual), default is manual.

Cycle-index window: display the cycle testing times of current setting, and the range is 0000-1000 times. 0000 means only single operation for compression and tension, and once the limit switch touch the limit ring, then the machine will stop and don't return.

Moving space key: character position of moving test times window.

Add key : increase the number in the times window preset, increase "1" when press the key one time.

Reduce key: minus the number in the times window preset, minus "1" when press the key one time.

Test times window: display the run times before("1" time when touch Upper limit validly).

Zero key: setting the running times to zero(only valid to test times window).

Attention

1. Choose the right test stand depend on your request. Please do not test over load.
2. Please do not remake or repair the equipment have not allowed for avoiding make more damage or could not repair.
3. Keep environment clean for avoiding liquid and scrap iron ect. to the bottom box, otherwise it will make element short out and make mechanical drive damaged.
4. Please do not use acute goods to jab operation panel and buttons for avoiding them could not work.
5. Using the limit function, please avoid limit circle drop and tamp injury

limited switch, let it could not work.

6. Add lube oil for Transmission of a pole when the equipment have already work long time.

7. Turn off the equipment when you did not use it in short time, pull out the power plug when you long time not use it, do not let it cover grieshoch and rust.

Operation Example

1. Examination before test:

- 1). Link to power, turn on the power, the display automatic take exam and simultaneous flicker 5 is normal;
- 2). When in "Mode" state, the indicate lamp is extinct, in the state of Manual test mode;
- 3). Operate without loading , check the sound of operate is in an average state, no anomalous sound.
- 4). Up/down limit function is ok, can limit position effective.

2. Function operation

M (Manual) Test

The machine is defaulted to Manual Mode, pilot lamp of "AUTO" is off. The lamp is shine when press it all the time, and the machine work to test. Loosen the button ,it will be off and the machine stop working to test. touching upper limit or lower limit when testing, the machine stop working to test.

A (Auto Cycle)Test

Press "mode shift" key, pilot lamp of "AUTO" is on. A (Autom cycle) mode test is working. Press the up or down button, it will shine and the machine works to test. when the number in the test time window is the same to the number in the time window preset in the mode test ,the machine stop working with 3 alarm buzzer, and end the test. Press stop button can stop machine's working in test and stop testing. Restart testing when repress up or down button. be attention to running time's record is valid after touching the up limit, so keep the same direction as restart as stop avoid losing "1"running time record.

Single Automatic Test

Press "mode shift" key, pilot lamp of "AUTO" is on. A (Auto cycle) mode test is working. Press the up or down button, the lamp is on and the machine works to test. Press "mode shift" key again, "auto" off, enter Manul test mode, now the equipment keep original move direction. During test, touching up limit or down limit , the test stand will stop work, and finish test.

Speed Adjustment of Moving Base Up and Down

The speed can be adjustable before test or during test. Adjust the speed displaying on "Speed display window" to what you need by adjusting the "Speed" button. As for test speed, please refer to the data in the spec form (Moving speed can be customized according to customer's requirement).

Pre-set Testing Times

The counter includes two parts. The upper is testing times(when power on, it shows the running times of last test), the lower is pre-set times. When applied in recycle test, set the value of each bit by using Moving space button, set the required counter value by Add button and Reduce button. Zero button is used for clean zero of the test times. Besides, single cycle times is better controlled within 2 hours, which aims to protect the machine and use it properly.

RS-232 Introduction(Available for Equipping SH, SP Series Force Gauge)

Test Stand connects to outside equipment through the RS-232 output. The test stand are connected to the computer by RS-232, installing the SD SJX.exe software from the CD to control up and down, stop function of the test stand. Connecting the instrument port to SH/SP series push pull force gauge, it has overload protection, It can also record the force value curve by the SD SJX.exe in CD.(Note:SH/SP series push pull force gauge applied with CD, the test stand do not.)

Due to the inertia of the machine, the force value displaying on the force gauge will overload when the test stops automatically. The value of the overload will change from the rigidity of the testing material. You can choose a appropriate low testing speed, or reduce the stopping value appropriately. More information about the operation, please refer to the CD adapting with SH,SP series push pull force gauge.

Limit Function

Under M (Manual) test mode, moving plate (down slide carriage) touch up limit or low limit, tester will stop. Under A(auto) test mode, moving plate (down slide carriage) touch up limit or low limit, it will stop 3~5 second then move in opposite direction. Only addup 1 time when the moving plate touch up limit. You should adjust the up limit and low limit distance when you test due to install the force gauge, clamp, test material , so it can avoid could not touch up or low limit not in time. If the moving plate could touch the limit in time may be let test failure or happen accident.

Packing List

Part	Model	SJX-500V	SJX-500H	SJX-1KV	SJX-1KVL	SJX-2KV	SJX-5KV	SJX-10KV	SJX-20KV	SJX-30KV
Main Body		1	1	1	1	1	1	1	1	1
220V Power Wire		1	1	1	1	1	1	1	1	1
M4 Inner Hexagon Spanner		0	1	0	0	0	0	0	0	0
M6 Inner Hexagon Spanner		1	0	1	1	1	1	1	0	0
M10 Inner Hexagon Spanner		0	0	0	0	0	1	1	1	1
M12X30Inner Hexagon Screw		0	0	1	1	1	0	0	0	0
Rs232 Wire		2	2	2	2	2	2	2	2	2
Screw Pillar of M10		4	4	4	4	4	4	4	4	4
M12X40Inner Hexagon Screw		0	0	0	0	0	0	1	0	0
D12 Spring Washer		0	0	1	1	1	0	1	1	1
D12 Flat Gasket		0	0	1	1	1	0	1	1	1
M12X75Inner Hexagon Screw		0	0	0	0	0	0	0	1	1
Manual		1	1	1	1	1	1	1	1	1
Qualification Card		1	1	1	1	1	1	1	1	1

CONTINUATION

Data of the manual is equally had newest product as evidence, because of improvement or other change, description of manual may differ from practical situation. Our company will reserve the right corrected at any moment, it is difficult to list the corrected place one by one.

Copyright of manual belongs to Wenzhou Sundoo Instruments Co., Ltd. Any unit and individual can't copy or plagiarize the part or full content.