

THIS COPY IS PROVIDED ON A RESTRICTED BASIS AND IS NOT TO BE USED IN ANY WAY DETRIMENTAL TO THE INTERESTS OF PANDUIT CORP.

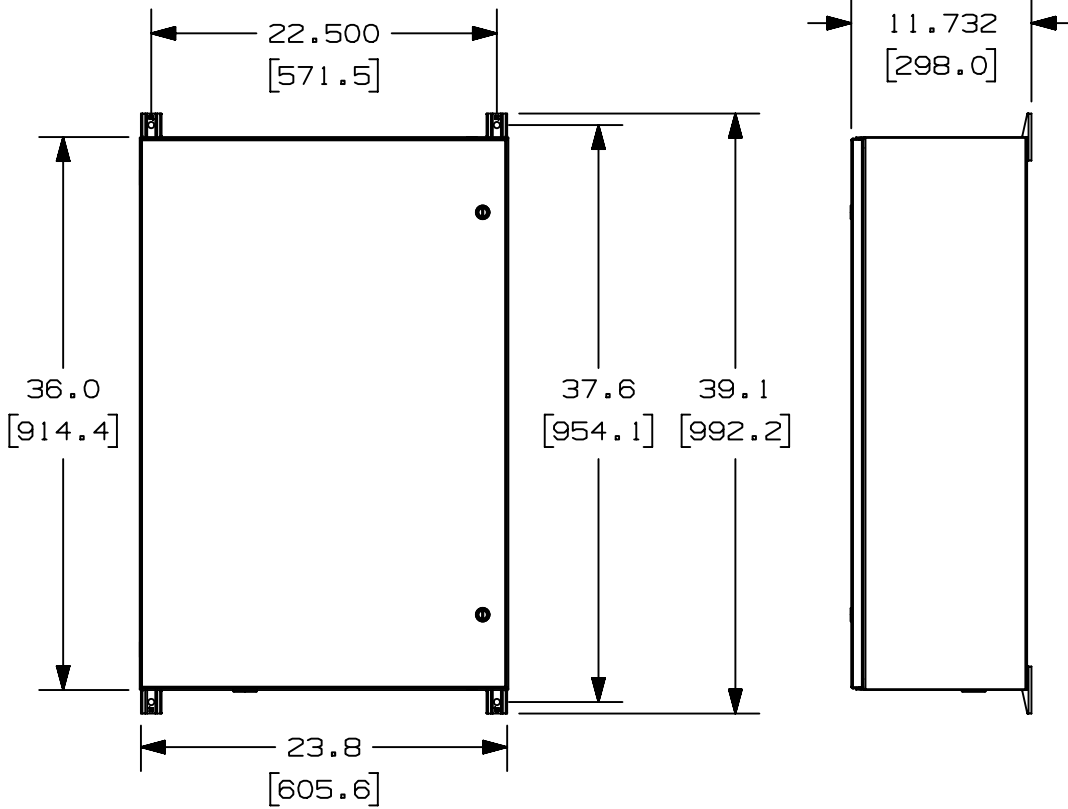

WIDTH	HEIGHT	DEPTH	WEIGHT
24.0"	36.0"	11.6"	110 LBS 50 KG

NOTES:

- DIMENSIONS IN PARENTHESES ARE IN METRIC.
- ENCLOSURE INCLUDES:
 - (2) CABLE MANAGEMENT SIDE PANELS
 - (1) TOP SLACK PLATE
 - (1) 1/2" CONDUIT PLUG FOR POWER ENTRY
 - (1) 6-PORT GROUND BAR
 - (4) EXTERNAL MOUNTING FEET
 - (1) AC WIRING COVER
 - (2) DIN RAIL FOR SWITCHES (16.0")
 - (1) DIN RAIL FOR POWER (20.5")
 - (1) 6 OR 12 PORT FIBER UPLINK PATCH PANEL (6 PORT-CBXF6BL-Y, 12 PORT-CBXF12BL-AY)
 - (1) FIBER SLACK SPOOL
 - (1) STRAIN RELIEF BAR
 - (1) 19", 2RU 48-PORT PATCH PANEL (CPP48WBLY)
 - (9) CABLE MANAGEMENT L RINGS
- ALL ZONE SYSTEMS ARE WALL MOUNTABLE WITH THE OPTION TO USE OUTSIDE EXTERNAL MOUNTING FEET.
- ALL ENCLOSURES ARE NEMA TYPE 4/12 AND IP66 RATED.
- 316 STAINLESS STEEL ENCLOSURES ARE RATED NEMA 4X.
- STEEL AND STAINLESS STEEL ENCLOSURES ARE MADE FROM 16 GAUGE STEEL

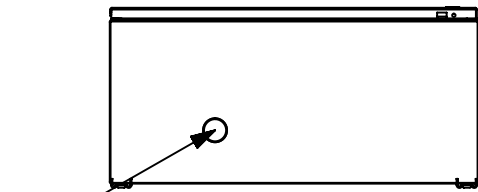

1/2" CONDUIT PLUG FOR POWER ENTRY

TITLE					
NETWORK ZONE SYSTEM, 24" X 36" ENCLOSURE WITH CABLE MANAGEMENT ACCESSORIES					
CUSTOMER DRAWING					
ITEM REVISION NAME			PANDUIT		
15V510CY/01					
DATASET FILE NAME			MATERIAL: N/A		
15V510CY_DC/01A					
UNLESS OTHERWISE SPECIFIED, DIMENSIONAL TOLERANCES ARE: IN [mm]					
.x ± .1 [2.54]		.xxx ± .005 [.127]		DRAWING NUMBER: 15V510CY	
.xx ± .01 [.25]		ANGLES ± 5 °			
		THIRD ANGLE PROJECTION		SHT 1 OF 2	
DRAWN BY	DATE	CHK	SCALE		
JBO	2/20/18	NWW	2:25	A	

REV	DATE	BY	CHK	APR	DESCRIPTION	ECN
01A	3/9/20	TYSH	SCL	KGA	RELEASED TO CUSTOMER	15V510CY
00A	2/20/18	JBO	NWW	TIMH	RELEASED TO CUSTOMER	15V510CY

D10100DA/14

THIS COPY IS PROVIDED ON A RESTRICTED BASIS AND IS NOT TO BE USED IN ANY WAY DETRIMENTAL TO THE INTERESTS OF PANDUIT CORP.

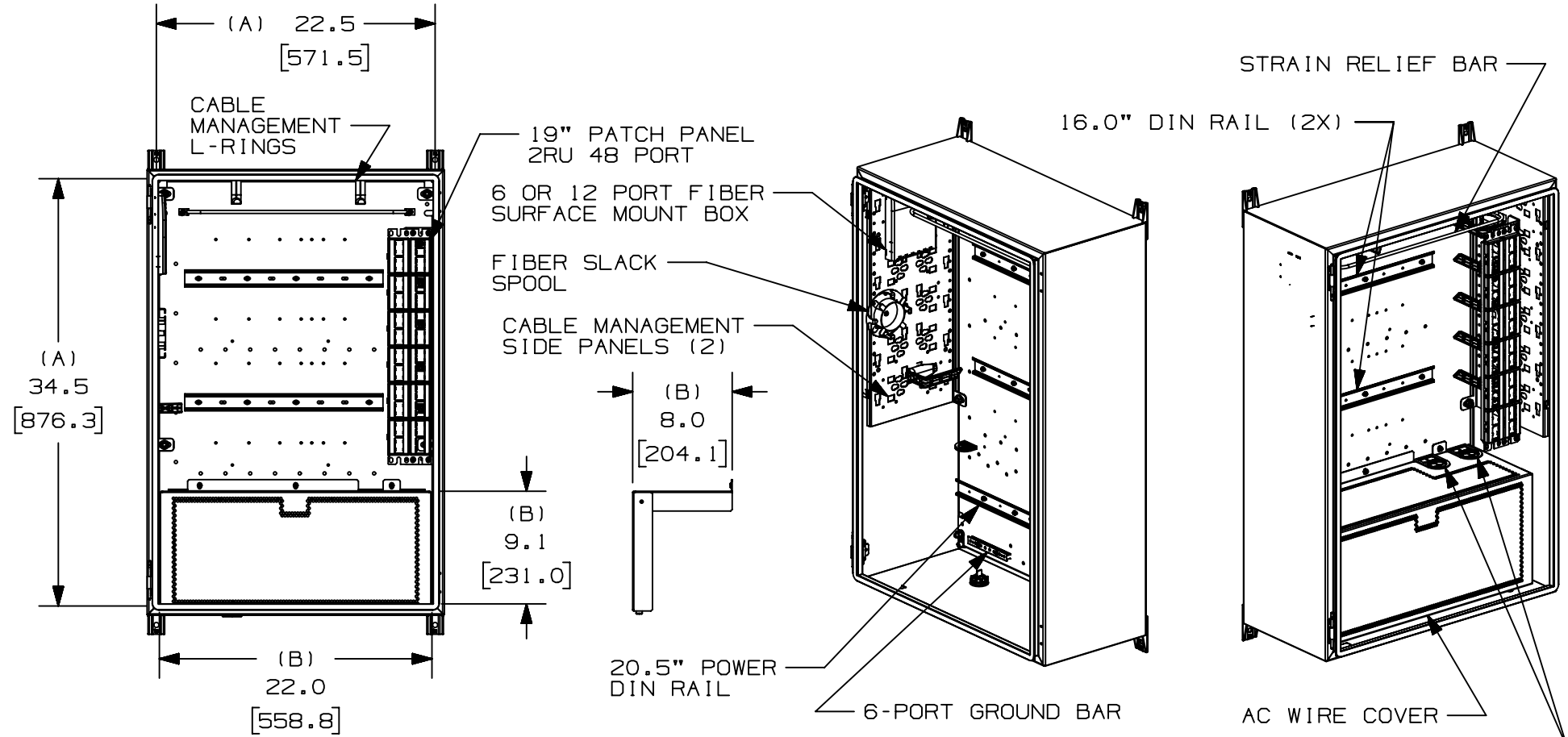

(A) DIRECT WALL MOUNT HOLE LOCATIONS
DOOR REMOVED FOR CLARITY
(B) DIMENSIONS UNDER THE AC WIRE COVER
AND OVER THE MOUNT PLATE

TITLE		NETWORK ZONE SYSTEM, 24" X 36" ENCLOSURE WITH CABLE MANAGEMENT ACCESSORIES	
CUSTOMER DRAWING			
ITEM REVISION NAME	15V510CY/01	PANDUIT	
DATASET FILE NAME	15V510CY_DC/01A		
UNLESS OTHERWISE SPECIFIED, DIMENSIONAL TOLERANCES ARE: IN [mm]		MATERIAL:	
.x ± .1 [2.54]	.xxx ± .005 [.127]	N/A	
.xx ± .01 [.25]	ANGLES ± 5 °	DRAWING NUMBER:	
THIRD ANGLE PROJECTION		15V510CY	
DRAWN BY	DATE	CHK	SCALE
JBO	2/20/18	NWW	2:25
REV	DATE	BY	CHK
01A	3/9/2020	TYSH	SCL
APR		KGA	REFER TO SHEET 1
DESCRIPTION	ECN	SHT 2 OF 2	
		A	

D10100DA/14