

THIS COPY IS PROVIDED ON A RESTRICTED BASIS AND IS NOT TO BE USED IN ANY WAY DETRIMENTAL TO THE INTERESTS OF PANDUIT CORP.

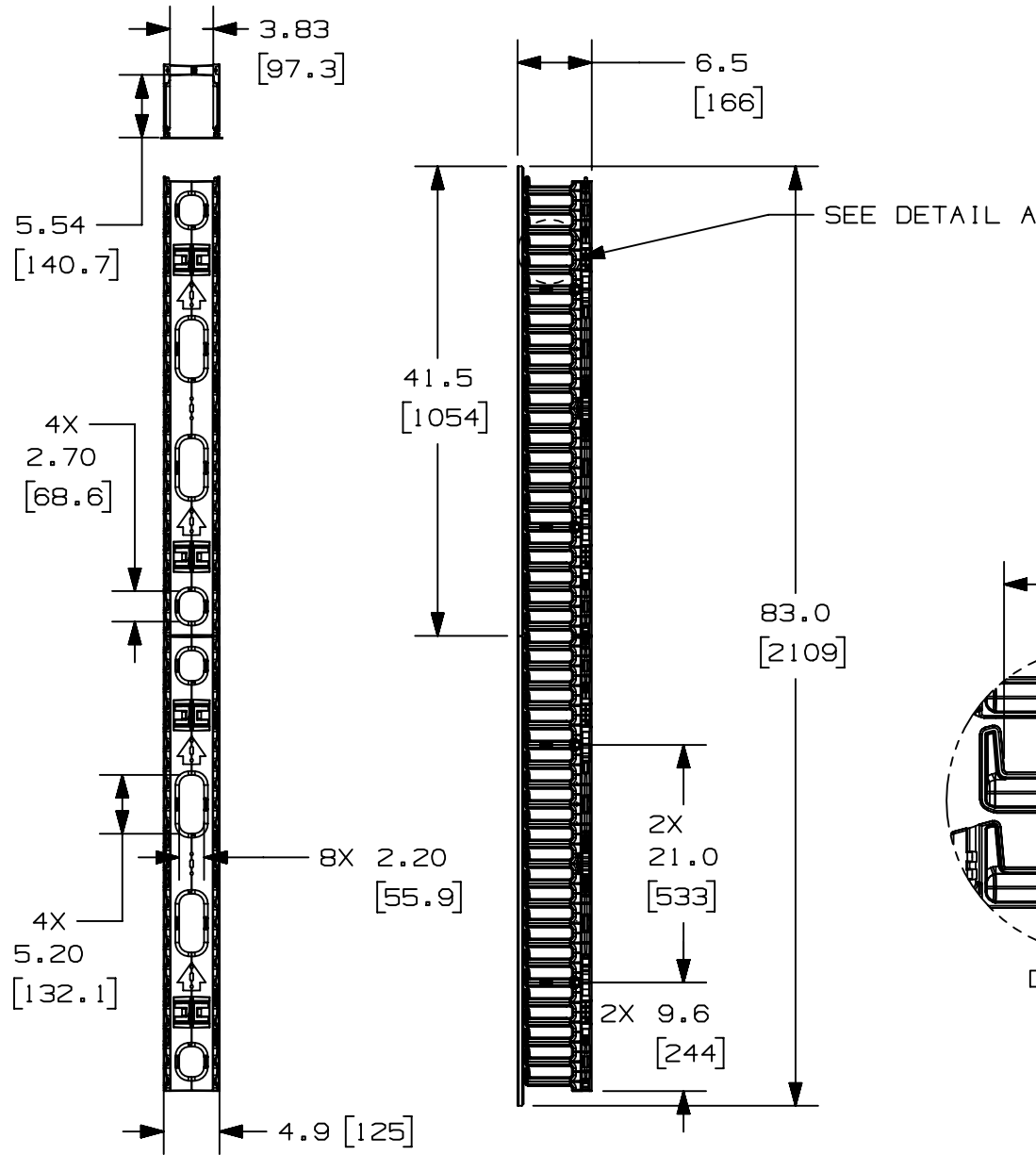

PANDUIT P/N	WEIGHT
WMPVF45E	14.0 LBS/EACH 6.35 Kg/EACH

- NOTES:
- VISIT OUR ON-LINE CATALOG AT WWW.PANDUIT.COM FOR A CURRENT LIST OF PRODUCTS APPLICABLE FOR USE WITH THIS PART.
 - COMPONENTS:
2- 22.5RU CABLE MANAGEMENT SECTIONS
2- 41.5" DUAL HINGE COVERS
4- MOUNTING BRACKETS
8- #12-24 X 1/2" SCREWS
 - DIMENSIONS IN PARENTHESES ARE METRIC.

MAX STORAGE TEMPERATURE 65°C (149°F)
MAX OPERATING TEMPERATURE 60°C (140°F)

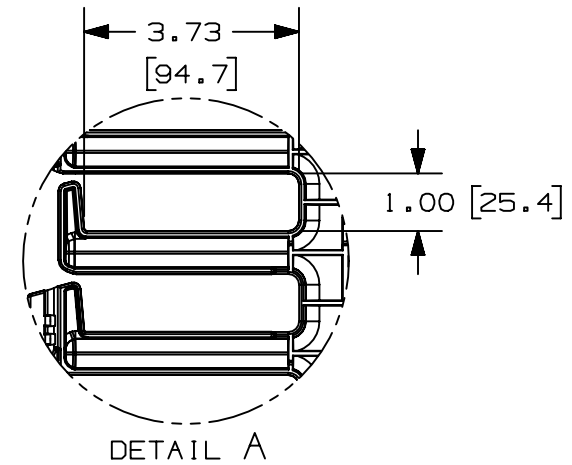

TITLE			
4" WIDE FRONT ONLY VERTICAL CABLE MANAGER WMPVF45E			
CUSTOMER DRAWING			
ITEM REVISION NAME		V10225AC/04	
DATASET FILE NAME		V10225AC_DC/04B	
		THIRD ANGLE PROJECTION	
MATERIAL		DRAWING NUMBER	
CABLE MANAGER- ABS COVER- PVC		10225-24	
DRAWN BY	DATE	CHK	SCALE
JDWE	3-15-05	TCK	NONE
SHEET 1 OF 2			SIZE
			A

A-SIZE CUSTOMER

04B	5-8-20	JBO	JCO	JEFK	ADDED TEMPERATURE NOTE	M09000LT
REV	DATE	BY	CHK	APR	DESCRIPTION	ECN

THIS COPY IS PROVIDED ON A RESTRICTED BASIS AND IS NOT TO BE USED IN ANY WAY DETRIMENTAL TO THE INTERESTS OF PANDUIT CORP.

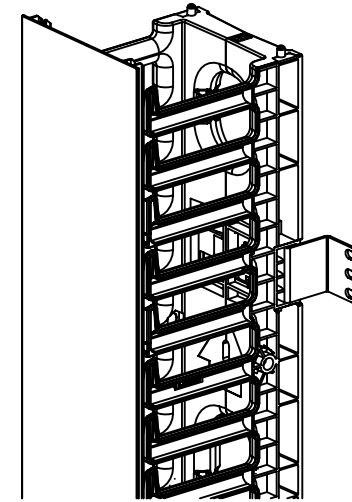
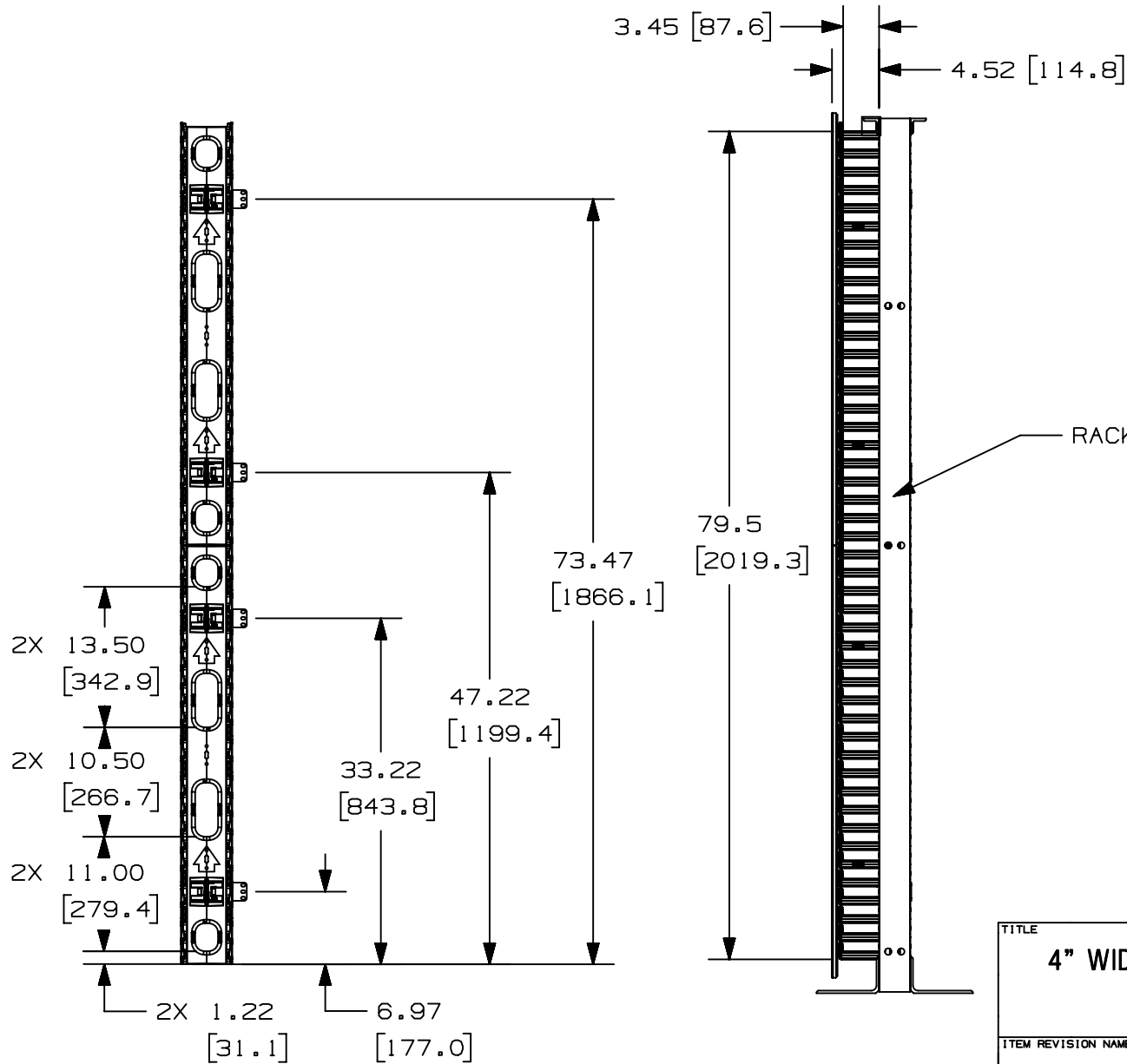

TITLE		4" WIDE FRONT ONLY VERTICAL CABLE MANAGER WMPVF45E	
ITEM REVISION NAME		CUSTOMER DRAWING	
DATASET FILE NAME		V10225AC/04	
MATERIAL		CABLE MANAGER- ABS COVER- PVC	
DRAWING NUMBER		10225-24	
DRAWN BY		DATE	
JDWE		3-15-05	
CHK		SCALE	
TCK		NONE	
SHEET 2 OF 2		A	

00A	5-8-20	JBO	JCO	JEFK	REFER TO SHEET 1 FOR REVISION CONTROL	M09000LT
REV	DATE	BY	CHK	APR	DESCRIPTION	ECN

A-SIZE CUSTOMER