

THIS COPY IS PROVIDED ON A RESTRICTED BASIS AND IS NOT TO BE USED IN ANY WAY DETRIMENTAL TO THE INTERESTS OF PANDUIT CORP.

PANDUIT P/N	WEIGHT
WMPVF22E	8.0 LBS/EACH 3.63 Kg/EACH

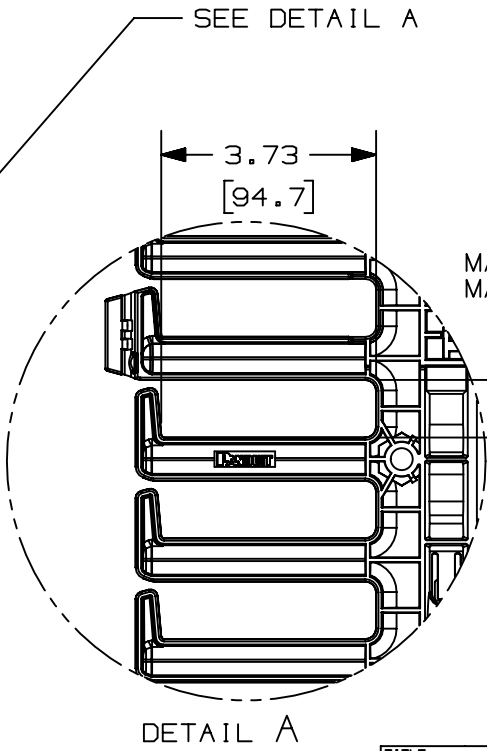
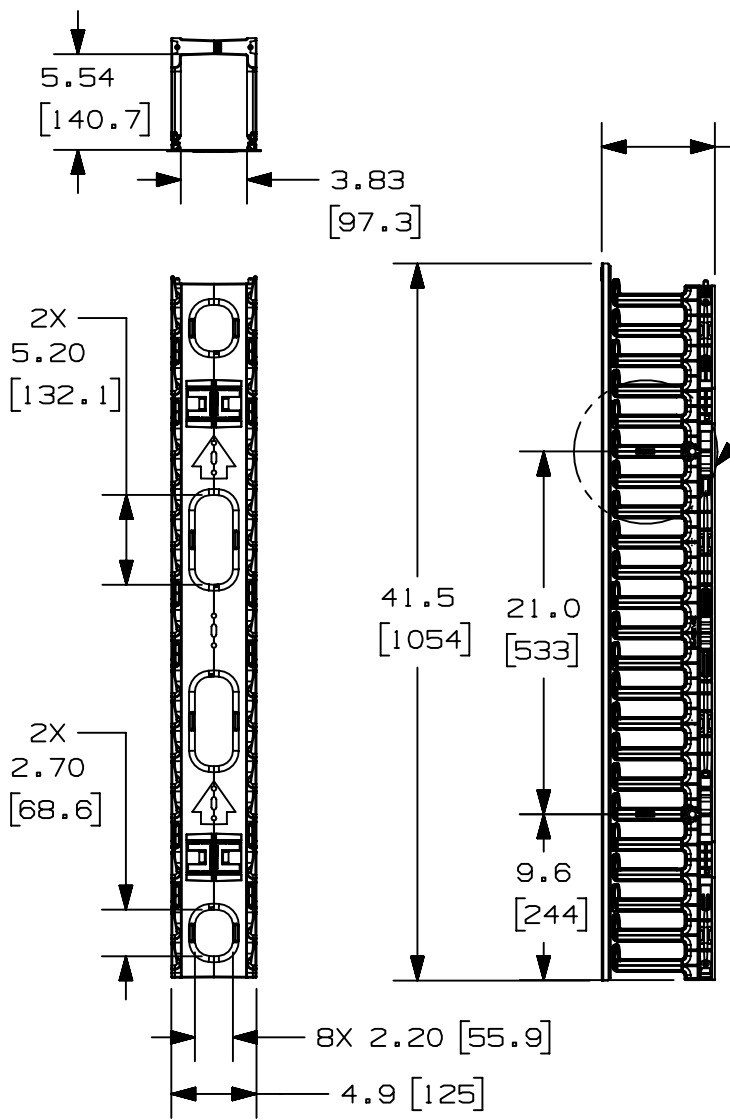

- NOTES:
- VISIT OUR ON-LINE CATALOG AT WWW.PANDUIT.COM FOR A CURRENT LIST OF PRODUCTS APPLICABLE FOR USE WITH THIS PART.
  - COMPONENTS:
    - 1- 22.5RU CABLE MANAGEMENT SECTIONS
    - 1- 41.5" DUAL HINGE COVERS
    - 2- MOUNTING BRACKETS
    - 4- #12-24 X 1/2" SCREWS
  - DIMENSIONS IN PARENTHESES ARE METRIC.

MAX STORAGE TEMPERATURE 65°C (149°F)  
MAX OPERATING TEMPERATURE 60°C (140°F)

TITLE <b>4" WIDE FRONT ONLY VERTICAL CABLE MANAGER WMPVF22E</b>		CUSTOMER DRAWING	
ITEM REVISION NAME V10225AF/04		<b>PANDUIT</b>	
DATASET FILE NAME V10225AF_DC/04B			
MATERIAL CABLE MANAGER- ABS COVER- PVC		DRAWING NUMBER 10225-28	
THIRD ANGLE PROJECTION	MATERIAL		
THIRD ANGLE PROJECTION	DRAWN BY JDWE	DATE 3-15-05	CHK MWH
THIRD ANGLE PROJECTION	SCALE NONE		SIZE A

A-SIZE CUSTOMER

04B	5-7-20	JBO	JCO	JEFK	ADDED TEMPERATURE NOTE	M09000LT
REV	DATE	BY	CHK	APR	DESCRIPTION	ECN

THIS COPY IS PROVIDED ON A RESTRICTED BASIS AND IS NOT TO BE USED IN ANY WAY DETRIMENTAL TO THE INTERESTS OF PANDUIT CORP.

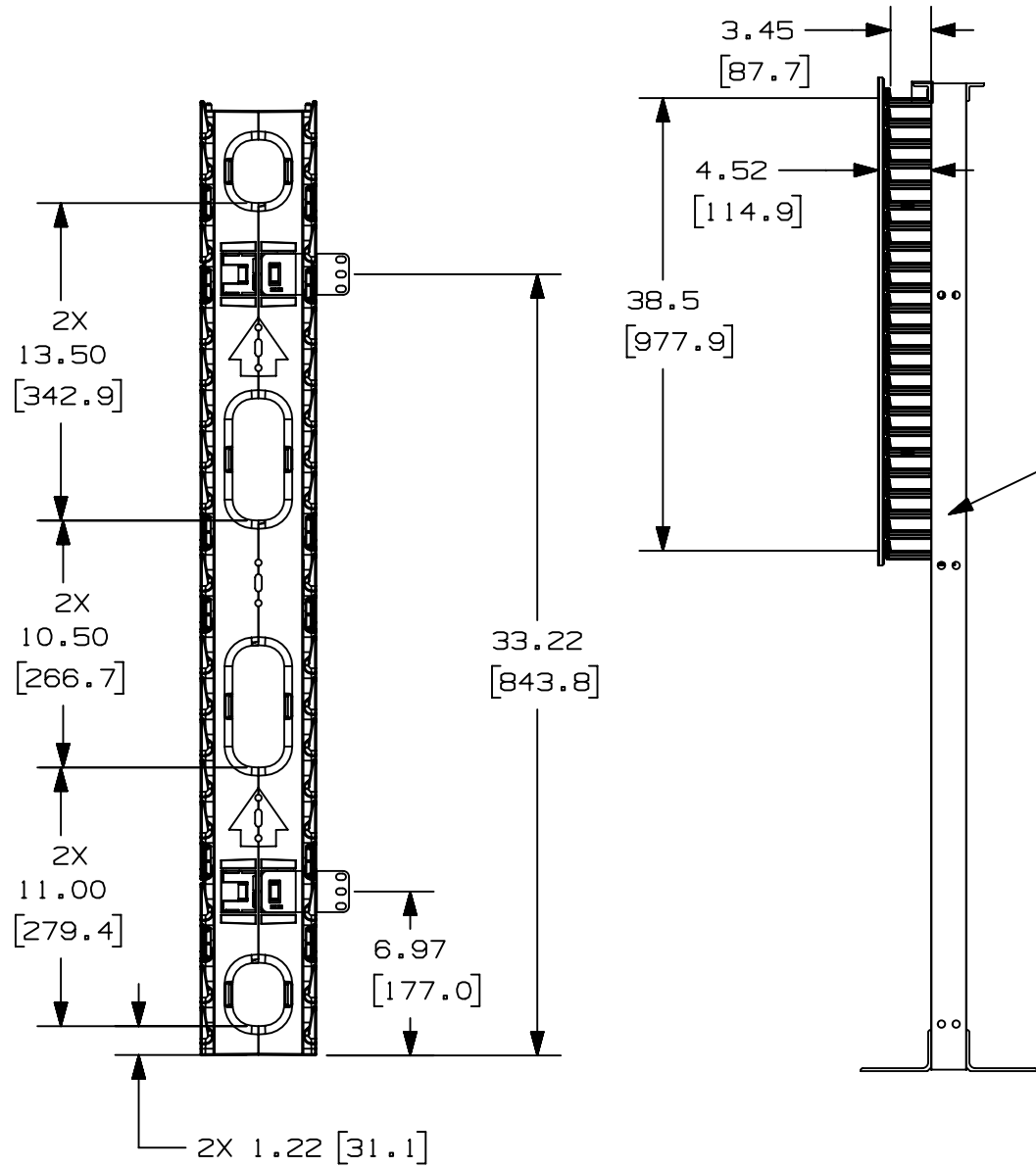

TITLE		4" WIDE FRONT ONLY VERTICAL CABLE MANAGER WMPVF22E	
ITEM REVISION NAME		CUSTOMER DRAWING	
DATASET FILE NAME		V10225AF/04	
MATERIAL		CABLE MANAGER- ABS COVER- PVC	
DRAWING NUMBER		10225-28	
DRAWN BY		DATE	
JDWE		3-15-05	
CHK		SCALE	
MWH		NONE	
SHEET 2 OF 2		SIZE	
A		A	

A-SIZE CUSTOMER

04B	5-7-20	JBO	JCO	JEFK	REFER TO SHEET 1 FOR REVISION CONTROL	M09000LT
REV	DATE	BY	CHK	APR	DESCRIPTION	ECN