

FINISH PART TAPE
"WOUND OUT"

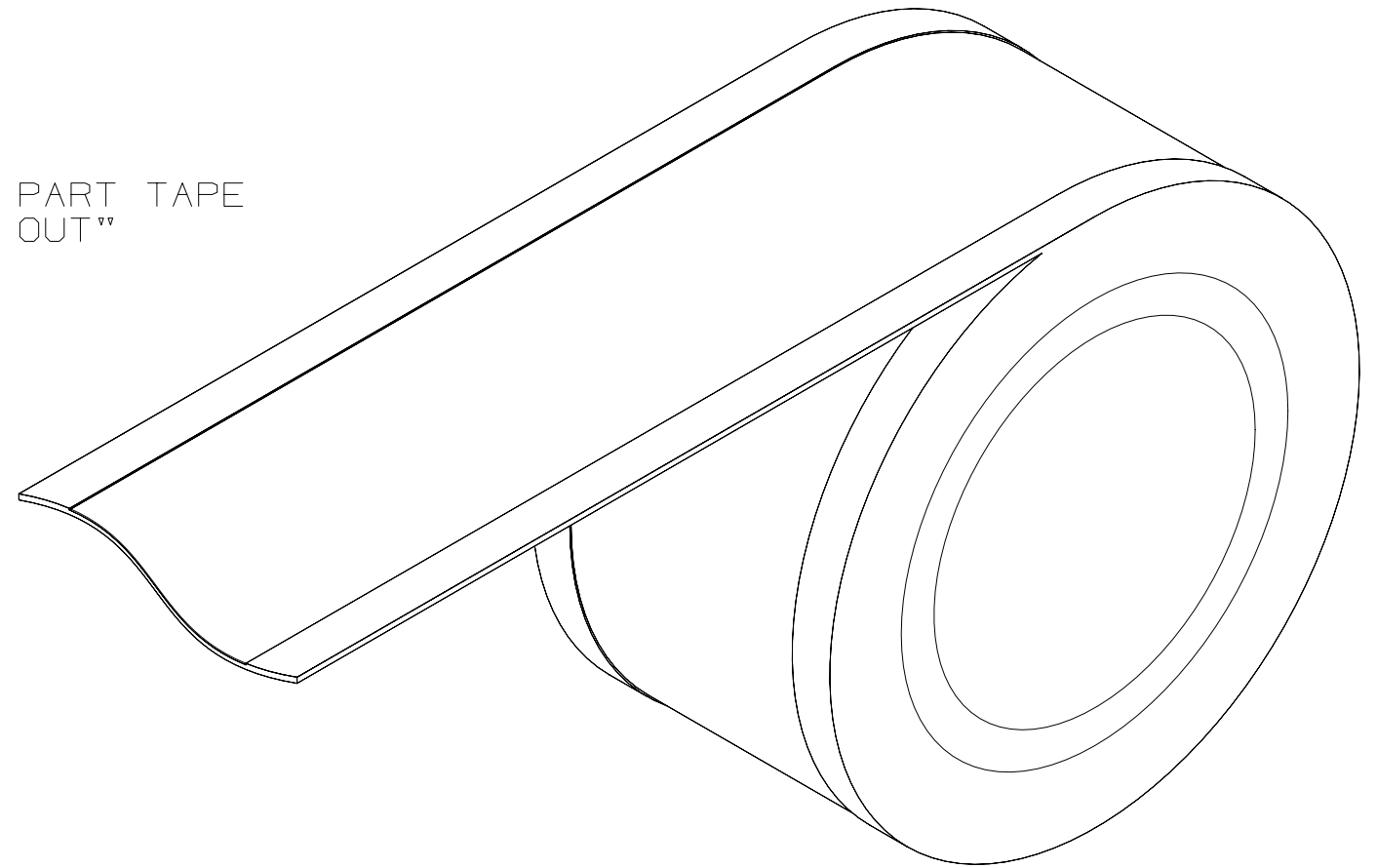

PART NO.	"A" (IN.) +/- .031" { 0.79 }	"B" (IN.) +/- 0.15" { 0.38 }	"C" (IN.) +/- .031" { 0.79 }	LENGTH MIN	MATERIAL ROLL PART NUMBER	COLOR	CORE	BAG	BOX
T200X000XP1	2.000 { 50.80 }	.063 { 1.60 }	2.125 { 53.98 }	360 { 9144 }	GM Y2-920W1JE-S	WHITE	GM CORE225-3BLU	GSBBAG1014	GSBBOX-1111JL-D
T400X000XP1	4.000 { 101.60 }	.063 { 1.60 }	4.125 { 104.79 }	360 { 9144 }	GM Y2-920W1JE-S	WHITE	GM CORE425-3BLU	GSBBAG1014	GSBBOX-1111JL-D

- NOTES:
1. MATERIAL TO BE MOUNTED ON 3" I.D. CORE.
 2. MATERIAL TO BE WOUND WITH PRINTING SURFACE OUT.
 3. NO SPLICES ALLOWED ON FINISHED PRODUCT.
 4. PRINTING SURFACE AND EDGE OF MATERIAL TO BE FREE OF DUST AND PARTICULATES.
 5. SEE CUSTOMER DRAWING NO. 00211EBM_DS.
 6. * DENOTES CRITICAL DIMENSION.

REV	DATE	BY	CHK	APR	DESCRIPTION	ECN
00A	4/27/2020	ACC	DAPE	RGB	DRAWING RELEASED	078299

PRODUCT SPEC 1003637	PACKAGING SPEC N/A				
PART NUMBER SEE TABLE	WORK INSTRUCTION N/A				
INSPECTION INSTRUCTION NUMBER N/A	FMEA & CONTROL PLAN NUMBER FMEA-781				
TITLE POLYESTER CONTINUOUS TAPE WITH SUPERTACK ADHESIVE FOR INK JET PRINTERS CONTROL DRAWING					
ITEM REVISION NAME 00211EBM/00	PANDUIT				
DATASET FILE NAME 00211EBM_DS/00A					
UNLESS OTHERWISE SPECIFIED, DIMENSIONAL TOLERANCES ARE: IN [mm] .X ± .1 [2.54] .XXX ± .005 [.127] .XX ± .01 [.25] ANGLES ± 5 °					
THIRD ANGLE PROJECTION					
DRAWING NUMBER: 00211EBM_DS					
DRAWN BY ACC	DATE 2/26/2020	CHK DAPE	SCALE N/A	DRAWING NUMBER: SHT 1 OF 1	SIZE B