

2

1

THIS COPY IS PROVIDED ON A RESTRICTED BASIS AND IS NOT TO BE USED IN ANY WAY DETRIMENTAL TO THE INTERESTS OF PANDUIT CORP.

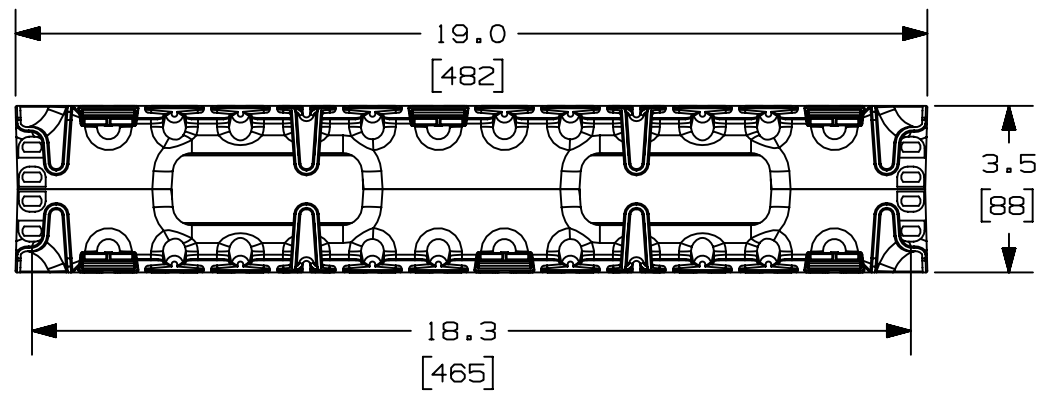

PANDUIT P/N	WEIGHT
NMF2 NMF2WH	1.6 LBS/EACH 730 g/EACH

- NOTES:
- VISIT OUR ON-LINE CATALOG AT WWW.PANDUIT.COM FOR A CURRENT LIST OF PRODUCTS APPLICABLE FOR USE WITH THIS PART.
 - COMPONENTS:
1- 2RU MANAGER (FRONT ONLY)
1- 2RU 19" COVER
 - DIMENSIONS IN PARENTHESIS ARE METRIC.

MAX STORAGE TEMPERATURE 65°C (149°F)
MAX OPERATING TEMPERATURE 60°C (140°F)

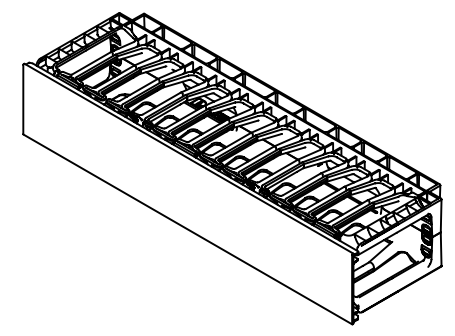
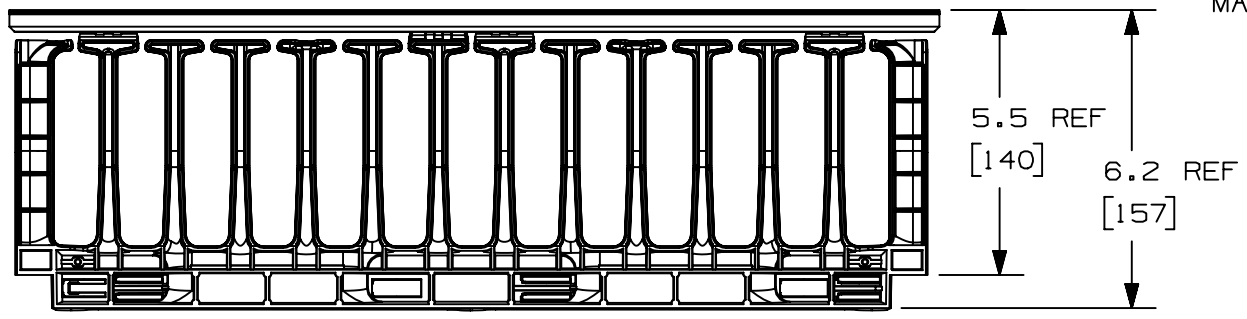

TITLE		NMF2 CABLE MANAGER										
		CUSTOMER DRAWING										
ITEM REVISION NAME		V10404AF/02										
DATASET FILE NAME		V10404AF_DC/02B										
		THIRD ANGLE PROJECTION										
MATERIAL		MANAGER: ABS 2RU COVER: PVC		DRAWING NUMBER								
				10404-16								
REV	DATE	BY	CHK	APR	DESCRIPTION	ECN	DRAWN BY	DATE	CHK	SCALE	SHEET	SIZE
02B	4/29/20	JBO	JCO	JEFK	ADDED TEMPERATURE NOTE	M09000LT	BAME	3/6/07	TCK	NONE	SHEET 1 OF 1	A

2

1

A-SIZE CUSTOMER