

THIS COPY IS PROVIDED ON A RESTRICTED BASIS AND IS NOT TO BE USED IN ANY WAY DETRIMENTAL TO THE INTERESTS OF PANDUIT CORP.

PAN-TY LOOP FOR
CABLE HOLD-DOWN
(4 PLACES)

BREAKOUT AREA
(3 PLACES)

POST FOR TAMPER
RESISTANT SCREW

MOUNTING HOLES
FOR #6 PAN HEAD
SCREW (2 PLACES)

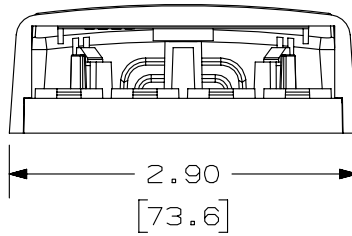
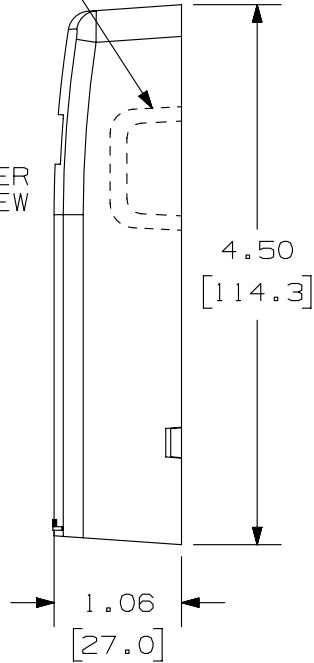
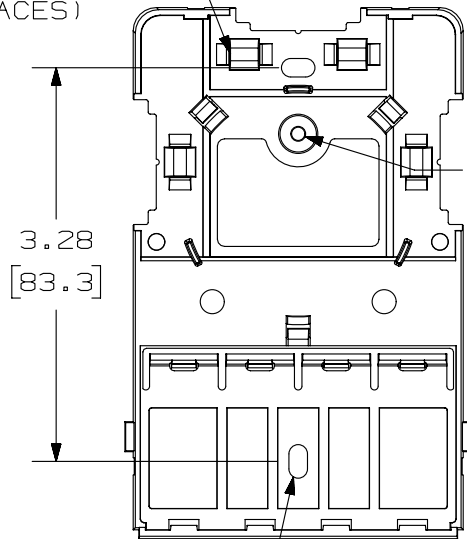

PANDUIT P/N	WEIGHT
CBX4**-AY	1.07 LB/10 PCS (485 g/10 PCS)

NOTES:

- SEE CURRENT CATALOG FOR ADDITIONAL PART NUMBER SUFFIXES TO INDICATE COLOR AND OR PACKAGE QUANTITY.
- SEE CATALOG FOR A COMPLETE LIST OF PARTS APPLICABLE FOR USE WITH THIS PART.
- DIMENSIONS IN PARENTHESES ARE IN METRIC.
- ALSO INCLUDED WITH BOX:
 - 1- BOX BASE
 - 1- BOX COVER
 - 2- PLT1.51-C PAN-TY
 - 2- MOUNTING SCREW
 - 1- MOUNTING SCREW (USED TO SECURE COVER TO BASE)
 - 1- LABEL/LABEL COVER
 - 2- STRIP OF 1.25" X .75" FOAM TAPE FOR MOUNTING
- BREAKOUTS DESIGNED TO ACCEPT LD3/LDPH3 OR LD5/LDPH5 RACEWAY.
- BASE MATERIAL THICKNESS= .090(2.29).

NO WARRANTY, EXPRESSED OR IMPLIED, IS MADE BY PANDUIT WITH RESPECT TO ADHESIVE BOND PERFORMANCE. AMONG OTHER THINGS, THE CONDITIONS UNDER WHICH THESE MOUNTS MAY BE APPLIED AND/OR THE SURFACE TO WHICH THEY MAY BE APPLIED ARE BEYOND PANDUIT'S CONTROL.

PART NUMBER		CBX4**-AY	
TITLE			
MINI-COM 4 POSITION SURFACE MOUNT BOX			
CUSTOMER DRAWING			
ITEM REVISION NAME		M02479E0/00	
DATASET FILE NAME		M02479E0_DC121/00B	
UNLESS OTHERWISE SPECIFIED, DIMENSIONAL TOLERANCES ARE: IN [mm]		MATERIAL:	
.x ± .xxx ± .010 [.3]		ABS	
.xx ± .03 [.8]		DRAWING NUMBER:	
THIRD ANGLE PROJECTION		02479-121	
DRAWN BY	DATE	CHK	SCALE
JSP	1-26-07	MJD	NONE
REV	DATE	BY	CHK
1	3/18/14	JSP	REFR
R	1-26-07	JSP	MJD
APR		MJD	
DESCRIPTION		ECN	
A. REVISED DRAWING TITLE BLOCK.		02479-121	
RELEASED TO PRODUCTION		02479-121	
SHT 1 OF 1		A	

D10100DA/14