

THIS COPY IS PROVIDED ON A RESTRICTED BASIS AND IS NOT TO BE USED IN ANY WAY DETRIMENTAL TO THE INTERESTS OF PANDUIT CORP.

NOTES:

1. VISIT OUR ONLINE CATALOG AT WWW.PANDUIT.COM FOR A LIST OF USE WITH THIS PRODUCT.
2. PRIMARY DIMENSIONS ARE IN MILLIMETERS (mm) DIMENSIONS IN PARENTHESES ARE IN INCHES (IN).
3. PARTS SUPPLIED:
 - 2 - BOTTOM SIDE PANELS
 - 2 - TOP SIDE PANELS
 - 1 - TOP FRONT PANEL
 - 1 - TOP REAR PANEL
 - 2 - BOTTOM FRONT AND REAR PANELS
 - 2 - HORIZONTAL ADJUSTMENT BRACKETS
 - 1 - HARDWARE KIT

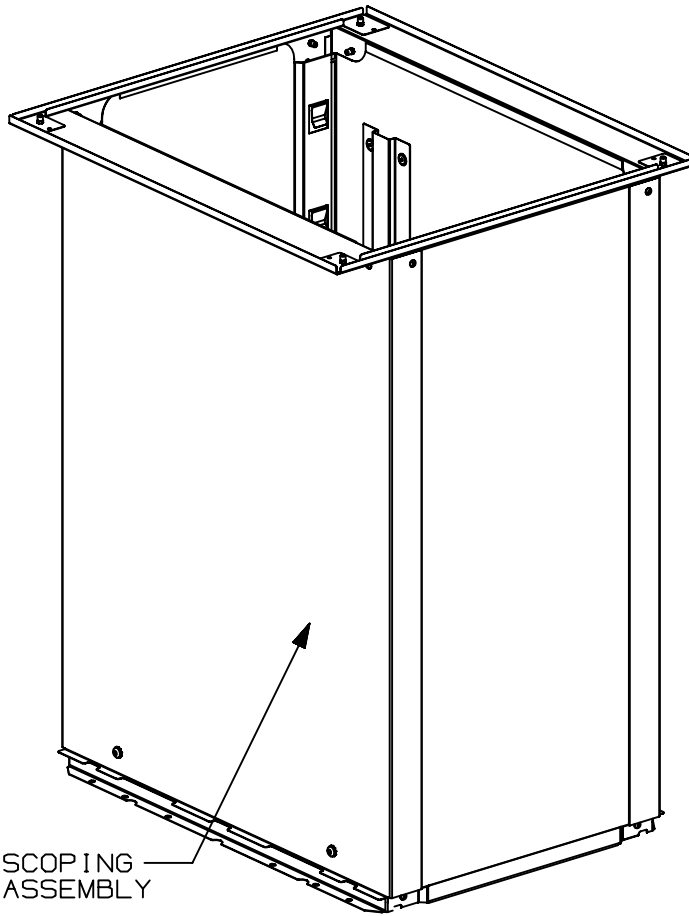

PANDUIT PART NO.	HEIGHT	FOR USE WITH CABINET SIZE (WIDTH X DEPTH)
C2VED06I1626XX	406mm [16"] - 660mm [26"]	600mm X 1200mm
C2VED06I2638XX	660mm [26"] - 965mm [38"]	600mm X 1200mm
C2VED06I3866XX	965mm [38"] - 1676mm [66"]	600mm X 1200mm
C2VED07I1626XX	406mm [16"] - 660mm [26"]	700mm X 1200mm
C2VED07I2638XX	660mm [26"] - 965mm [38"]	700mm X 1200mm
C2VED07I3866XX	965mm [38"] - 1676mm [66"]	700mm X 1200mm
C2VED08I1626XX	406mm [16"] - 660mm [26"]	800mm X 1200mm
C2VED08I2638XX	660mm [26"] - 965mm [38"]	800mm X 1200mm
C2VED08I3866XX	965mm [38"] - 1676mm [66"]	800mm X 1200mm

*XX = COLOR
 B1 = BLACK
 W1 = WHITE
 G1 = GREY



REV	DATE	BY	CHK	APR	DESCRIPTION	ECN
01B	11-13-19	LEE	RAMA	SJP	D. ADDED GREY TO PART NO. COLOR CODE (SHT 1)	V09002DW/00
01A	02/11/13	ERK			C. UPDATED PARTS SUPPLIED LIST B. ADDED SHEET 4 A. UPDATED TO REFLECT NEW GEOMETRY AND HARDWARE	12V285ZV
00A	10/16/12	PJST	BKR	BKR	RELEASED TO PRODUCTION	12V285ZV

TITLE					
NET-CONTAIN VERTICAL EXHAUST DUCT FOR N OR S TYPE CABINETS					
CUSTOMER DRAWING					
ITEM REVISION NAME			12V285ZV/01		
DATASET FILE NAME			12V285ZV_DC/01B		
MATERIAL:			PANDUIT		
			N/A		
DRAWING NUMBER:			12V285ZV		
DRAWN BY	DATE	CHK	SCALE		
PJST	10/16/12	BKR	N/A	SHT 1 OF 4	A

D10100DA/12

2

1

THIS COPY IS PROVIDED ON A RESTRICTED BASIS AND IS NOT TO BE USED IN ANY WAY DETRIMENTAL TO THE INTERESTS OF PANDUIT CORP.

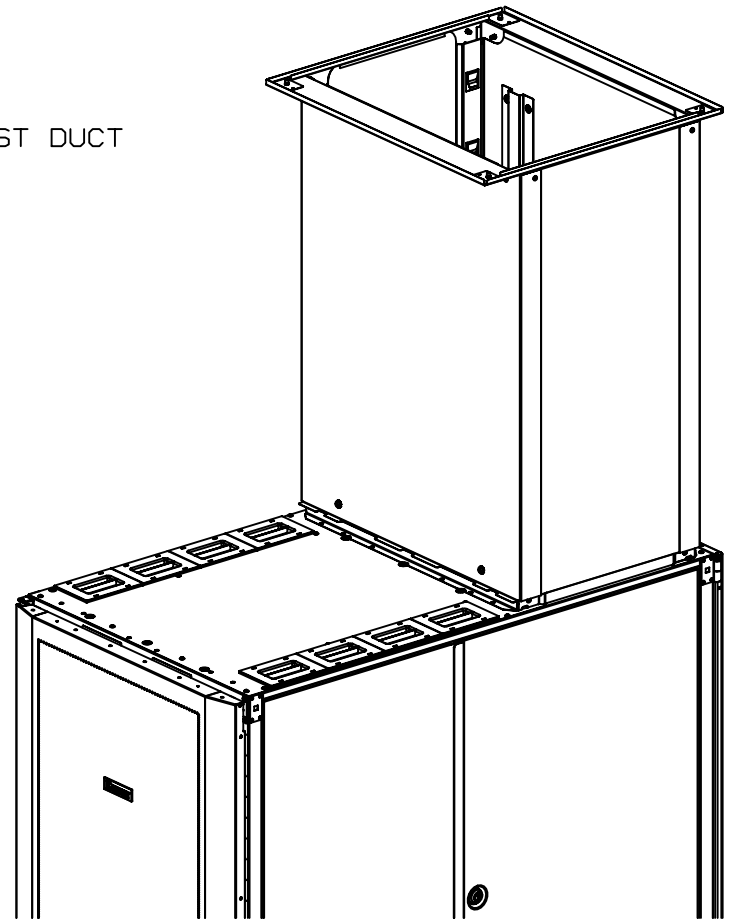
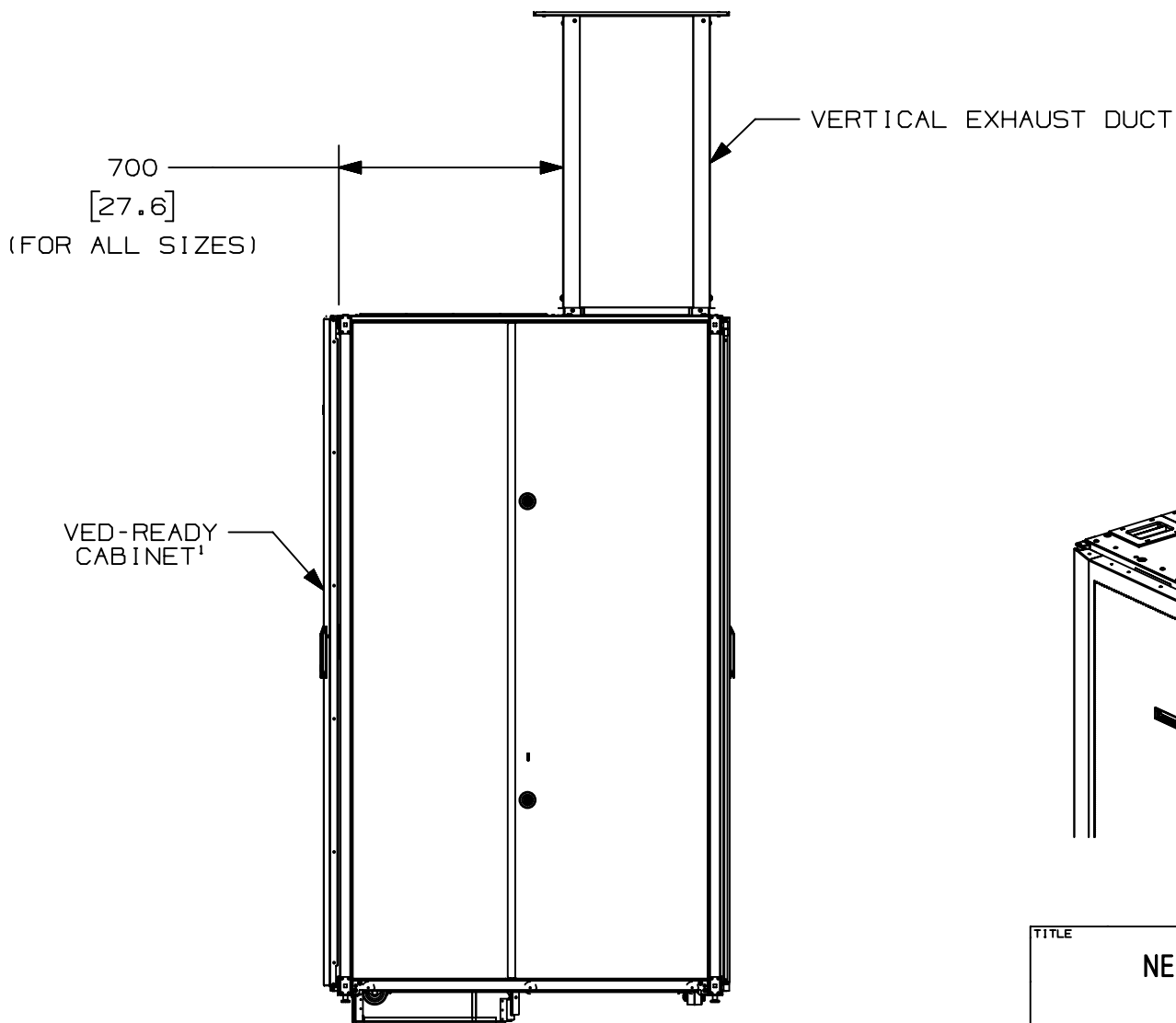

1. THE NET-CONTAIN™ VERTICAL EXHAUST DUCT CAN ONLY BE USED WITH A VED-READY TYPE CABINET (PURCHASED SEPARATELY).

TITLE									
NET-CONTAIN VERTICAL EXHAUST DUCT FOR N OR S TYPE CABINETS									
CUSTOMER DRAWING									
ITEM REVISION NAME					12V285ZV/01				
DATASET FILE NAME					12V285ZV_DC/01B				
MATERIAL:								N/A	
DRAWING NUMBER:								12V285ZV	
DRAWN BY	DATE	CHK	SCALE	SHT 4 OF 4			SIZE	A	
PJST	10/16/12	BKR	N/A						

01B	11-13-19	LEE	RAMA	SJP	SEE SHEET 1 OF 4 FOR REVISIONS	V09002DW/00
--	---	--			SEE SHEET 1 OF 4 FOR REVISIONS	12V285AP
REV	DATE	BY	CHK	APR	DESCRIPTION	ECN

2

1

D10100DA/12