

## ProZoom® 4.5



## ProZoom® 6.5



## Ergo-Zoom®



## O.C. White Dual Ball Bearing Base Components

- A)** Base & Post Assembly
- B)** Safety Collar & Handle
- C)** Glide Arm Assembly
- D)** Large Handle
- E)** Large Handle
- F)** Small Handle
- G)** 20mm Drop Arm Assembly
- H)** Safety Stop
- I)** 8mm Hex Key

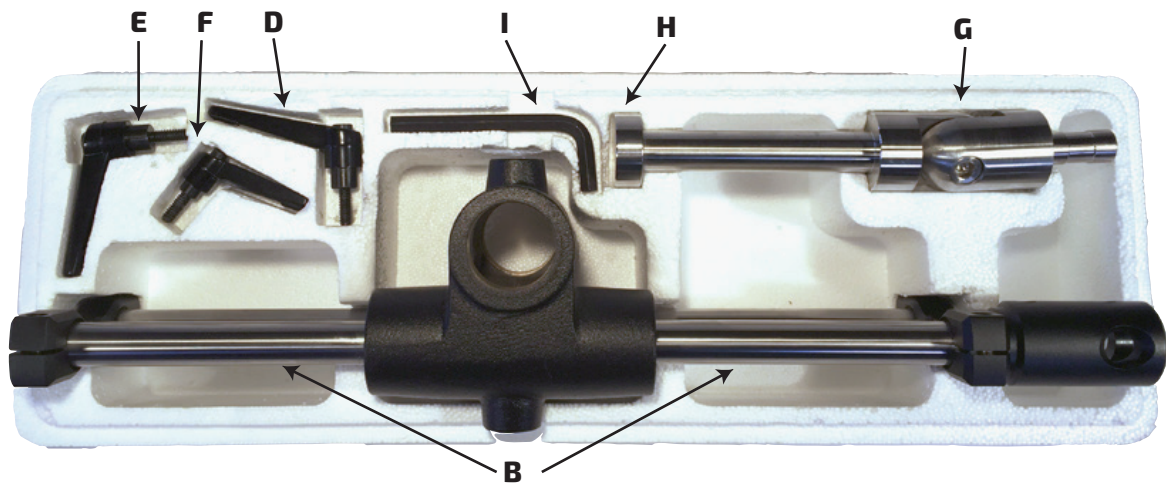
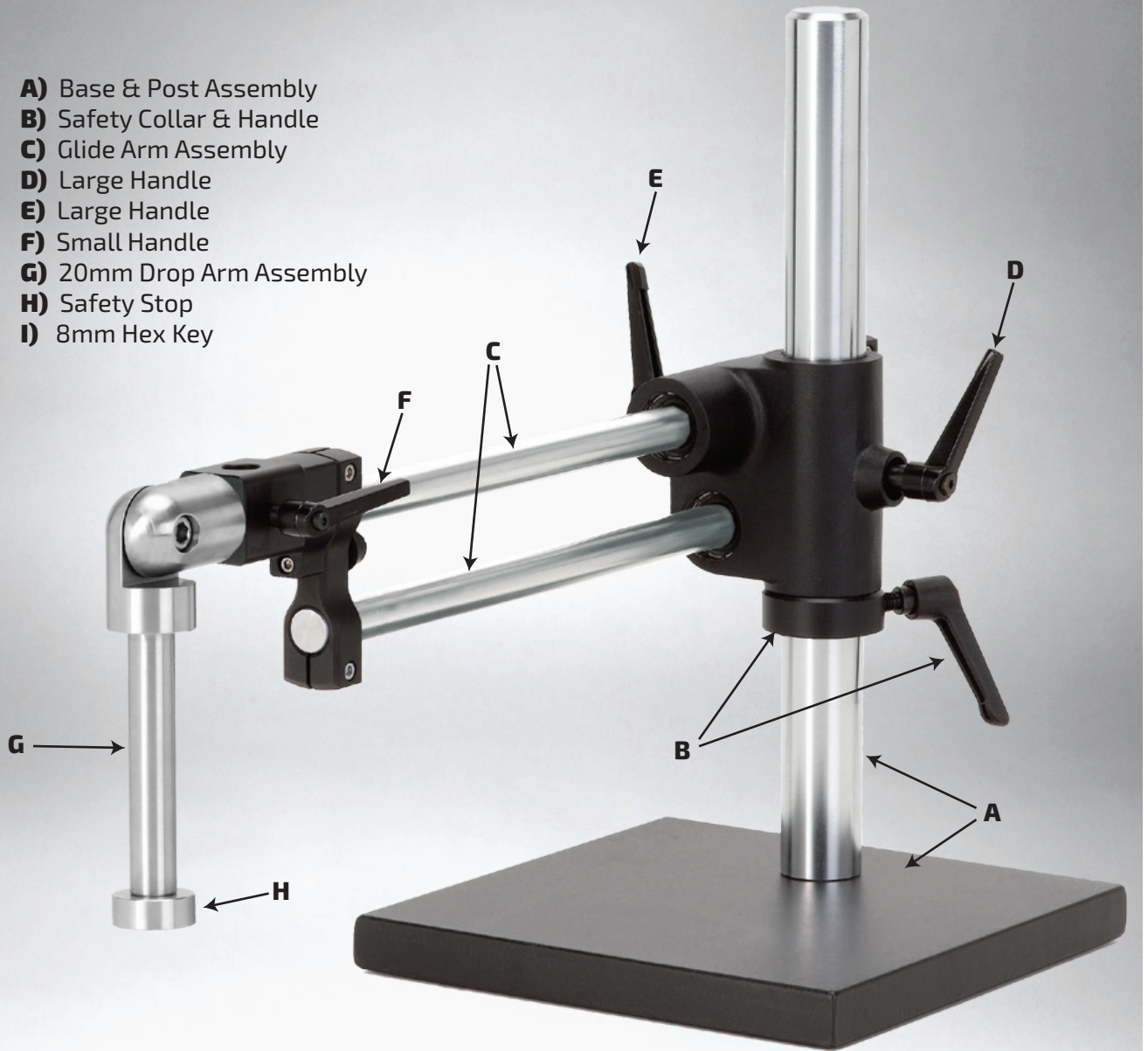

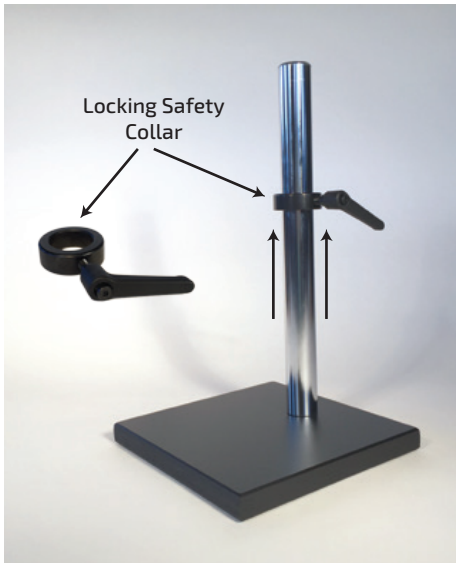

**1.** Place the base stand on a sturdy level surface and position Safety Collar at approximate working distance. Tighten lock handle firmly.



**2.** Insert Locking Handles into Glide Arm locations shown and screw in several turns. Do not tighten.



**3.** Slide Glide Arm down post to Safety Ring. Tighten post locking handle firmly.



**4.** Slide Drop Arm into socket at the end of the Glide Arm. Loosen the locking bolt with the 8mm Hex Key to position shaft plumb to the floor. Tighten very firmly.

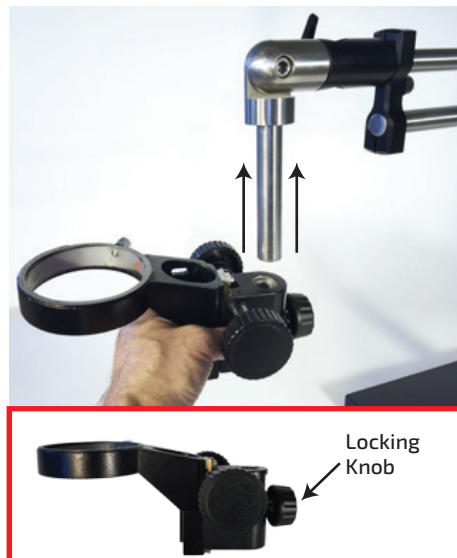

**5.** Slide microscope Focusing Mount up onto shaft. Tighten the Locking Knob lightly.

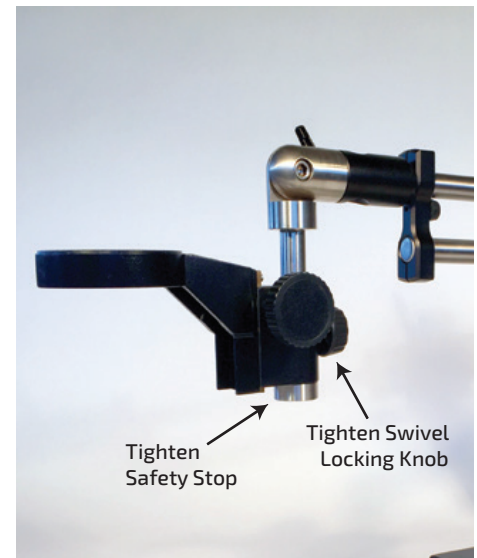

**6.** Screw Safety Stop onto end of shaft tightly. Reposition Focusing Mount down to Safety Stop and tighten. Adjust position of Focusing Mount and tighten the Swivel Locking Knob.

## O.C. White Articulating Arm Components

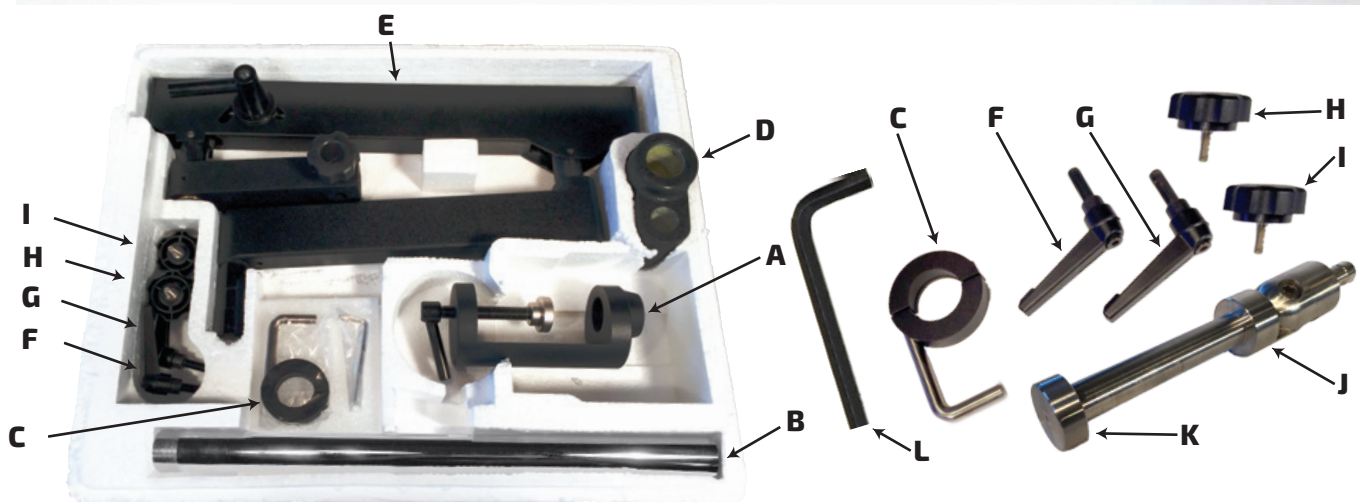

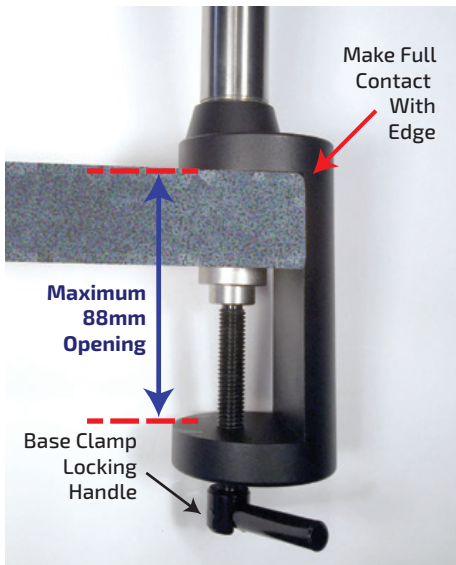

**1.** Screw Main Post into Base Clamp Base then Slide jaw of Base Clamp onto edge of table top. Ensure full contact of the clamp.

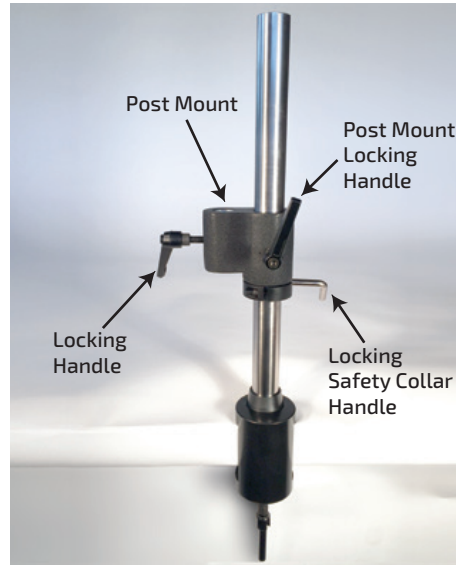

**2.** Position Safety Collar at approximate working distance. Tighten its lock handles firmly. Insert locking handles into Articulating Arm locations shown and screw in several turns, but do not tighten.

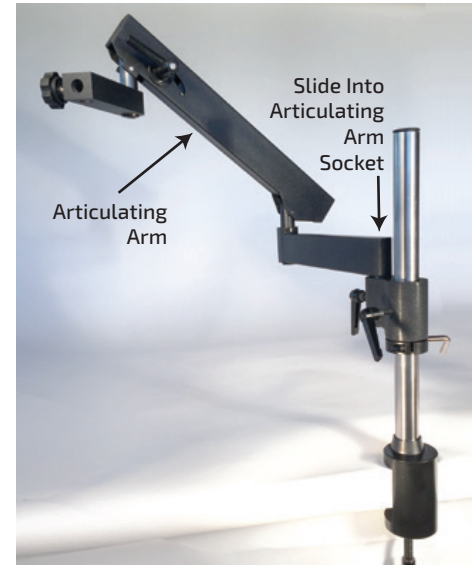

**3.** Slide Articulating Arm into Flex Arm socket. Tighten post locking handle firmly.

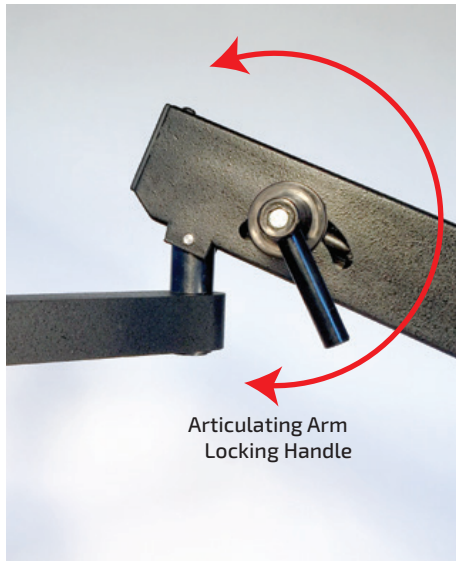

**4.** The angle adjustment of the Articulating Arm will be routinely secured by the Locking Handle. Loosen counter-clockwise to desired angle and tighten firmly.

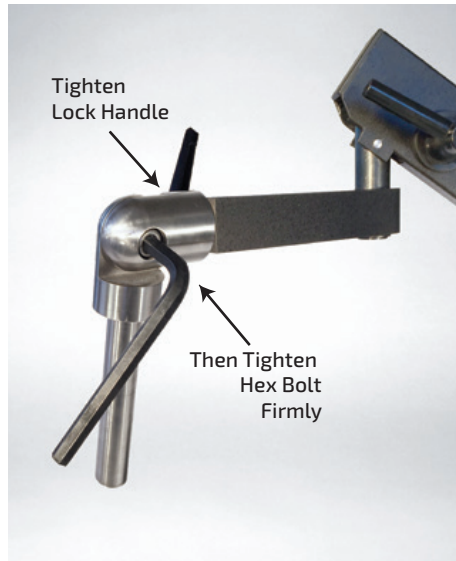

**5.** Slide Drop Arm into socket at end of Articulating Arm. Loosen hex bolt and position shaft plumb to floor. Tighten locking handle first, then tighten hex nut very firmly.

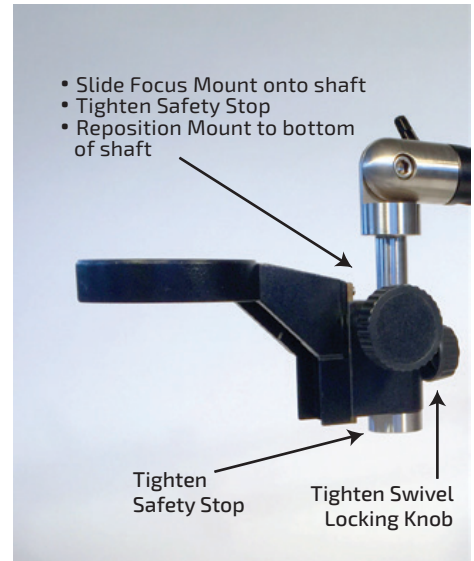

**6.** Slide Focus Mount onto Drop Arm shaft. Lightly tighten knob. Screw Safety Stop onto end of shaft firmly. Reposition Focusing Mount down to Safety Stop and tighten knob. Slide microscope head into Focus Mount opening and secure small locking knob.

## How to Setup and Parfocal Your Microscope.

### WHY PARFOCAL YOUR MICROSCOPE?

Parfocaling enables you to cycle through your microscope's zoom range without losing focus.

1. Adjust the body of your microscope to the approximate **WORKING DISTANCE** that you will be working at (with the focusing mount at its middle position).

2. Adjust the independent diopter adjustments on each eyepiece tube and set to the Zero/Halfway mark, which is the centerpoint displayed as the symbol **[+|-]**.



3. Adjust the interpupillary distance on the microscope head to your **eye comfort**.

Look through the eyepieces and adjust the distance between lens tubes until you're viewing a single image.

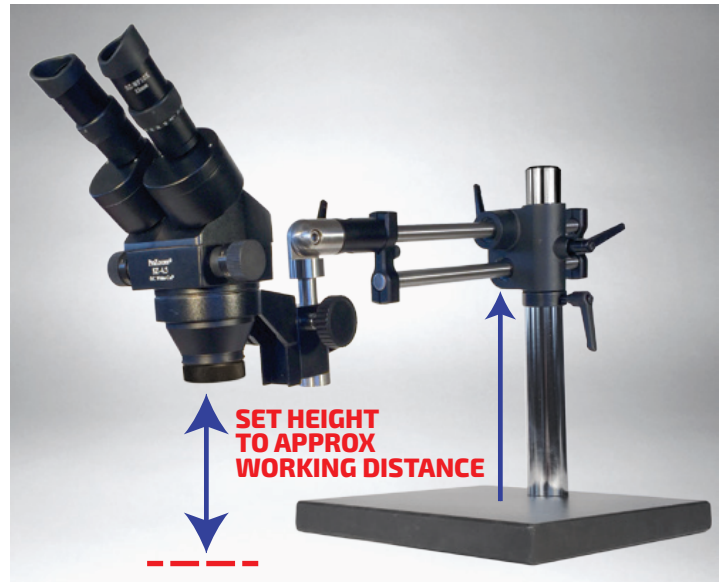

### FIT THE EYEPIECES: Rotate Eyepieces Until Both Images Overlap Into One Image

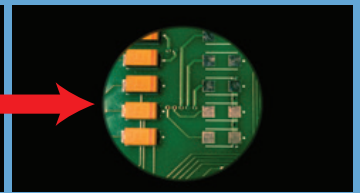
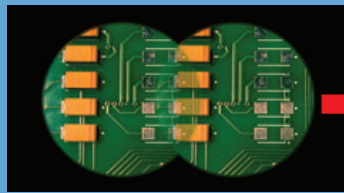

4. Set Zoom Knobs to the **HIGHEST** magnification setting.

5. Look into the eyepieces, and adjust the height of the microscope (via focusing arm) to bring the image into focus. **Disregard on screen image** (trinocular models) until after the microscope body parfocal procedure is accomplished. This is addressed separately.

6. Set Zoom Knobs to the **LOWEST** magnification setting.

7. Determine dominant eye, and leave it open (closing other).

8. Adjust eyepiece diopter until items in view are perfectly focused.

9. Close dominant eye, and open other. Repeat this step.

10. Open both eyes, and zoom through the scope range to ensure 100% parfocal performance.



**NOTE:** For trinocular microscope models, keep the microscope body set to its **lowest zoom setting**, and twist the knurled rubber ring on the CCD adapter until what you see is in focus. Verify focus by zooming through the entire magnification range, and adjust slightly if required. This focus adjustment should not need to be completed again unless you remove the camera.

## AIMS ADVANCED IMAGING & MEASUREMENT SUITE

INTEGRATED SOFTWARE FUNCTIONS FOR ALL CAMERA BASED SYSTEMS

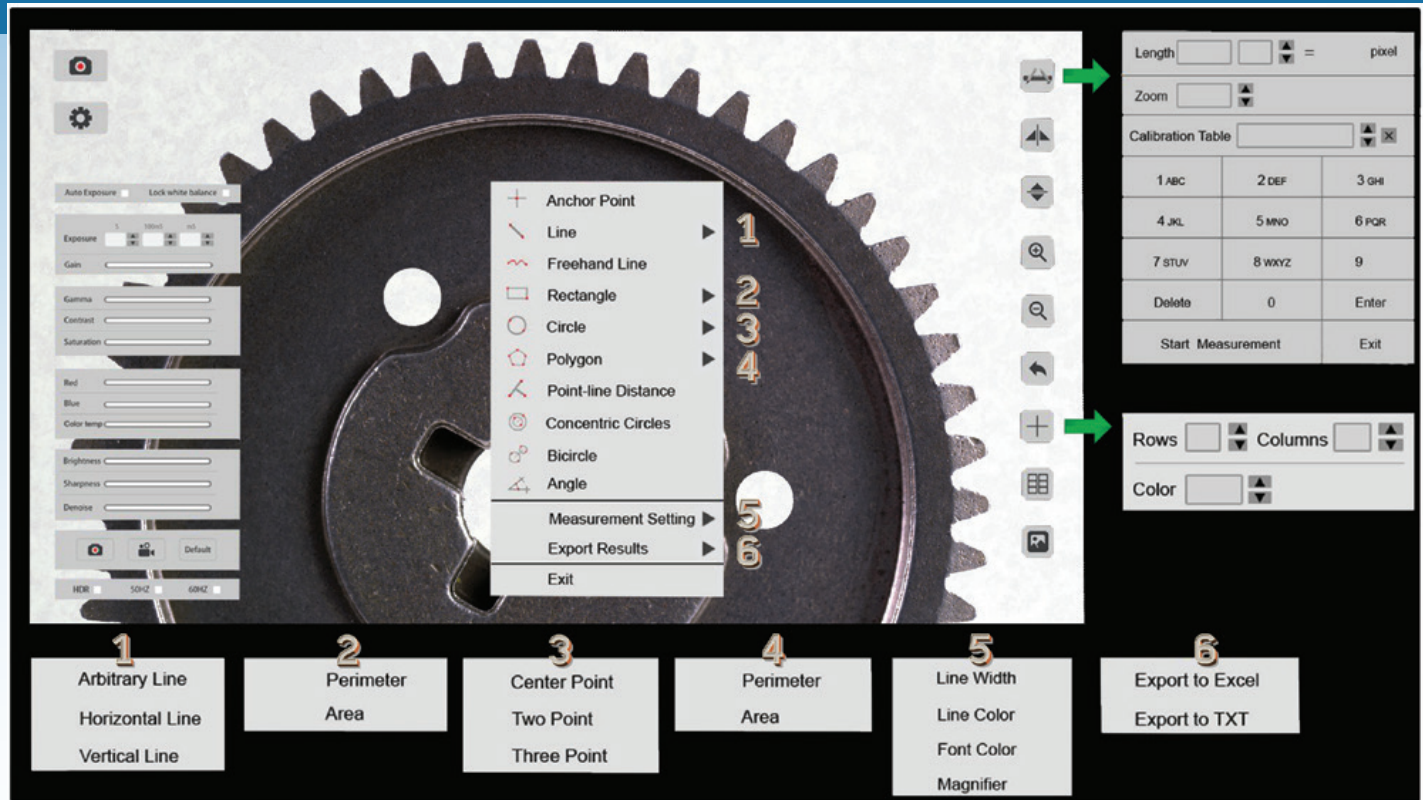

Each system ships with our exclusive **5MP Hybrid HDMI/USB Camera**. This exceptional smart camera pulls double duty for both production and quality assurance needs. It features both HDMI and USB outputs, and has integrated **smart camera controls** with a **host of onboard software features** including:



### Image Capture

Quickly capture image and videos while inspecting **directly to the 8GB SD card**. Sort and archive to a PC.



### Calibrated Measure

An entire array of Measurement Tools for **high precision** and repeatable measurements without a PC!



### Real Time Compare

Compare live video feed with previous captured images. Search and sort for **instant comparison**.



### Ultra-High Sensitivity

Industry leading low light sensitivity allows for crystal clear images where competitors cameras fail. **More sensitivity** requires less light for less glare!

## NEW! AIMS PC Suite

ADDS REMARKABLE FEATURES TO AIMS FOR MAXIMUM PRODUCTIVITY AND PRECISION!



### Extended Depth of Focus

This specialized tool allows for 'stacking' of multiple image captures of tall objects taken at various focal lengths, into a single **super high clarity image**.



### Image Stitching

Inspecting something that is just too big to view all at once? Capture multiple images of the object, then 'stitch' them together digitally to **create a single extra-large image**.

## ProZoom® 4.5 Technical Data

Eyepiece		Main Body	0.5X SZ-OB-050	0.75X SZ-OB-075	1X SZ-OB-100	1.5X SZ-OB-150	2X SZ-OB-200
10X	MAG:	7-45X	3.5-22.5X	5.3-33.8X	7-45X	10.6-68X	14-90X
	FOV:	31.4-4.9mm	62.8-9.8mm	41.9-6.5mm	31.4-4.9mm	20.9-3.3mm	15.7-2.5mm
15X	MAG:	10.5-67.5X	5.3-33.8X	7.9-50.6X	10.5-67.5X	15.8-101.2X	21-135X
	FOV:	21.4-3.4mm	42.8-6.7mm	28.5-4.4mm	21.4-3.4mm	14.2-2.3mm	10.7-1.7mm
20X	MAG:	14-90X	7-45X	10.6-67.5X	14-90X	21.2-135X	28-180X
	FOV:	17.1-2.7mm	34.2-5.3mm	22.9-3.6mm	17.1-2.7mm	11.4-1.8mm	8.5-1.4mm
25X	MAG:	17.5-112.5X	8.8-56.3X	13.1-84.4X	17.5-112.5X	26.3-168.8X	35-225X
	FOV:	12.8-2mm	25.7-4mm	17.1-2.7mm	12.8-2mm	8.5-1.4mm	6.4-1mm
<b>Working Distance</b>		<b>88 mm</b>	<b>137 mm</b>	<b>103 mm</b>	<b>88 mm</b>	<b>38 mm</b>	<b>29 mm</b>

## ProZoom® 6.5 Technical Data

Eyepiece		Main Body	0.37X PZ-OB-037	0.5X PZ-OB-050	0.7X PZ-OB-070	1.0X PZ-OB-100	2.0X PZ-OB-200
10X	MAG:	10-65X	3.7-24.1X	5-32.5X	7-46X	10-65X	20-130X
	FOV:	23-3.5mm	62.2-9.6mm	46-7mm	32.9-5mm	23-3.5mm	11.5-1.8mm
15X	MAG:	15-97.5X	5.55-36.1X	7.5-48.8X	10.5-69X	15-97.5X	30-195X
	FOV:	17-2.6mm	45.9-7.1mm	34-5.2mm	24.3-3.7mm	17-2.6mm	8.5-1.3mm
20X	MAG:	20-130X	7.4-48.1X	10-65X	14-92X	20-130X	40-260X
	FOV:	14-2.2mm	37.8-5.8mm	28-4.2mm	20-3.1mm	14-2.2mm	7-1.1mm
30X	MAG:	30-195X	11.1-72.2X	15-97.5X	21-138X	30-195X	60-390X
	FOV:	9-1.4mm	24.3-3.7mm	18-2.7mm	12.9-2mm	9.0-1.4mm	4.5-0.7mm
<b>Working Distance</b>		<b>110 mm</b>	<b>275 mm</b>	<b>195 mm</b>	<b>145 mm</b>	<b>110 mm</b>	<b>35 mm</b>

## Ergo-Zoom® EZ-850 Technical Data

Eyepiece		EZ-OB-050A (.5x Achromatic)	EZ-OB-050 (.5x Plan APO)	EZ-OB-100 (1x Std. in Kit)	EZ-OB-200 (2x Plan APO)
10X	MAG:	4-25X	4-25X	8-50X	16-100X
	FOV:	60-9.6mm	60-9.6mm	30-4.8mm	15-2.4mm
15X	MAG:	6-37.5X	6-37.5X	12-75X	24-150X
	FOV:	40-6.4mm	40-6.4mm	20-3.2mm	10-1.6mm
20X	MAG:	8-50X	8-50X	16-100X	32-200X
	FOV:	30-4.8mm	30-4.8mm	15-2.4mm	7.5-1.2mm
<b>Working Distance</b>		<b>200 mm</b>	<b>126 mm</b>	<b>78 mm</b>	<b>32.5 mm</b>

### THERE'S MORE ONLINE!

For complete optical data on all three Ergo-Zoom® microscope models including accessories, please visit:

[www.ocwhite.com](http://www.ocwhite.com)

