



NRS Series User Manual

Single-Stage Oil-sealed Rotary Vane Vacuum Pump



NAVAC Inc.

Add: 1099 Wall Street West, Suite 242
Lyndhurst, NJ 07071
T +1 201.939.6699
F +1 201.939.3899
info@navacglobal.com
www.navacglobal.com

Contents

1. Use Information.....	1
2. Attention	1
3. Description	4
3.1 Principle of Operation.....	5
3.2 Principle of Gas Ballast	5
4. Technical Parameters	5
5. Transport and Storage	6
6. Installation and Connection.....	7
6.1 Installation Dimensions.....	7
6.2 Connection to System	7
6.3 Power Supply and Motor Rotation Direction	8
7. Initial Start and Operation	9
7.1 Start-up	9
7.2 Operation	10
8. Inspection and Maintenance	10
8.1 Inspection	11
8.2 Maintenance	11
9. Troubleshooting	13
10. Warranty	15
11. Accessories	15
11.1 NRS20 Exploded View	16
11.2 NRS20 Spare Parts List.....	17
11.3 NRS22/28 Exploded View	18
11.4 NRS22/28 Spare Parts List	19
11.5 NRS40/65 Exploded View	20
11.6 NRS40/65 Spare Parts List	21
11.7 NRS100 Exploded View	22
11.8 NRS100 Spare Parts List	23
11.9 NRS160/200 Exploded View	24
11.10 NRS160/200 Spare Parts List	25
11.11 NRS300 Exploded View	26
11.12 NRS300 Spare Parts List	27

1. Use information

Dear distinguished customer,

Thanks for choosing NAVAC vacuum pump of high reliability (Hereinafter referred to as “the pump”).

Please check carefully whether the product received is the same as you ordered and the accessories, spare parts & operating manual are attached as well. Please also check if there’s any damage occurred during transportation. If needed, contact the local distributor or our sales team.

In order to maintain a stable performance level of the pump, read this operating manual carefully to fully understand the safety instructions, technical data as well as operating procedures before installation, operation, repair and maintenance of the pump.

Warning

Failure to observe the terms could result in serious personal injury.

Notice

Failure to observe the terms could result in damage to the pump.



This warning label indicates risk of electrical shock. Disconnect the pump from the power supply before beginning with connections, repair and maintenance. Make sure the cover of junction box is properly installed before running.



This warning label indicates high temperature hazard. Do not touch the pump when the pump is in operation.

Notice

Read the operating manual carefully and follow the operating procedures. We reserve the right to modify the design and technical data of the pump without notice which may have discrepancies with the manual. Add vacuum oil as requested before starting the new pump.

2. Attention

In order to ensure the personal safety, read the operating manual carefully before installation, operation, repair and maintenance.

Warning

According to the technical guidelines and wiring regulations for electrical equipment, the power supply must match with the information shown on the pump nameplate and the electrical connections must be performed by a skilled electrician.

 **Warning**

To prevent electrical hazards and sudden start-up hazard which may result in personal injury, disconnect the power supply before checking or repairing the pump.

 **Warning**

Before starting the pump, the motor must be effectively grounded and properly connected with a rated motor protection switch.

 **Warning**

The pump is strictly prohibited to pump dusty, active toxic, corrosive, flammable and explosive gases.

 **Warning**

Do not place obstacles which may affect the ventilation of the motor and cause burn hazard and fire by abnormal temperature rise.

 **Warning**

The exhaust passage must be unimpeded before operating. Make sure that the gas flow from the exhaust port is not blocked or restricted in any way.

 **Notice**

The pump must be operated at ambient temperature between 10 - 40°C.

 **Notice**

Check the oil level before running. Do not operate the pump without oil or short of oil. Otherwise it will result in pump failure.

 **Notice**

Check oil leakage of the pump to prevent slip hazard caused by spilled oil.

 **Notice**

Solid particles are not allowed to pass into the pump.

 **Notice**

Running without oil lubrication or wrong rotation direction of the motor may cause pump failure.

 **Notice**

Do not connect the intake port with an overpressure device. Make sure the size of the exhaust passage with absolute pressure is not more than 1.35 bar (relative pressure is not more than 0.35 bar).

 **Notice**

Handling of used oil and other parts must be in compliance with local relevant environmental laws and regulations.

 **Notice**

To pump condensable gases, only use the pump installed with gas ballast.

 **Notice**

While pumping a small amount of dust and condensable gases, an installation of corresponding filters is required. Otherwise it will cause pump failure or sharp drop of performance.

3. Description

The vacuum pump is an oil sealed single-stage rotary vane pump. It is a basic equipment to obtain vacuum and can be used to pump inactive gas within the scope of low vacuum and a small amount of non-condensable gas.

The pump is specially suitable for packaging machines, freeze drying, vacuum transfer, medical technology, melting furnaces, analytical instruments, laboratory, etc. It can be used as a backing pump for roots pumps as well.

The pump has a reasonable structure design for long failure-free operation. Air cooled and low noise level. High displacement speed and excellent ultimate vacuum. No oil spray and leak, easy to maintain.

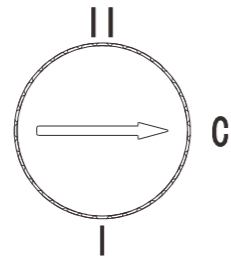

Fig.1 Gas Ballast Valve

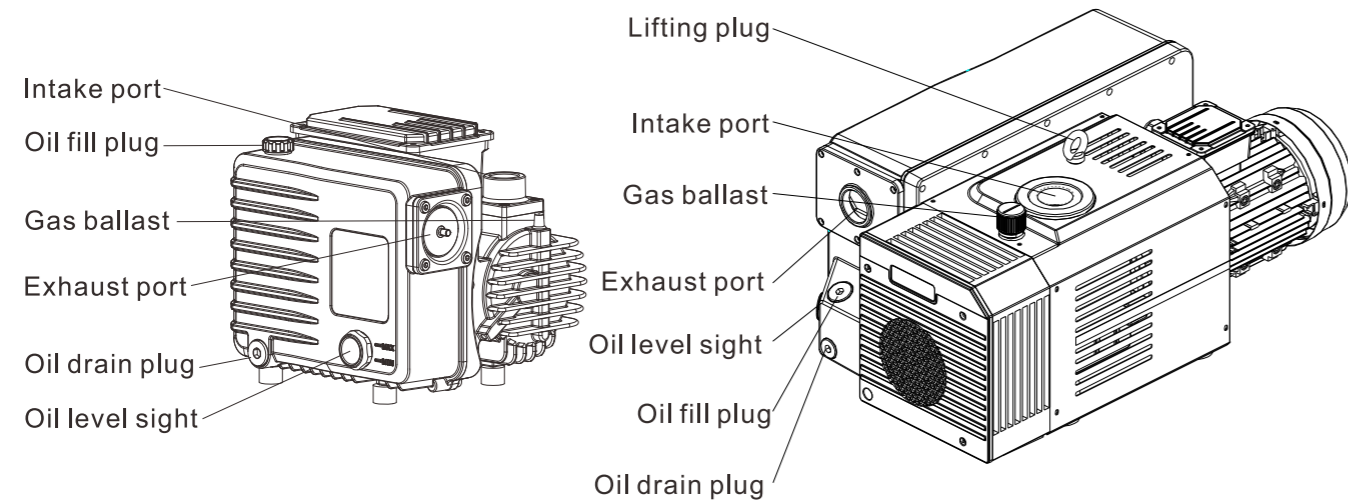

Fig.2

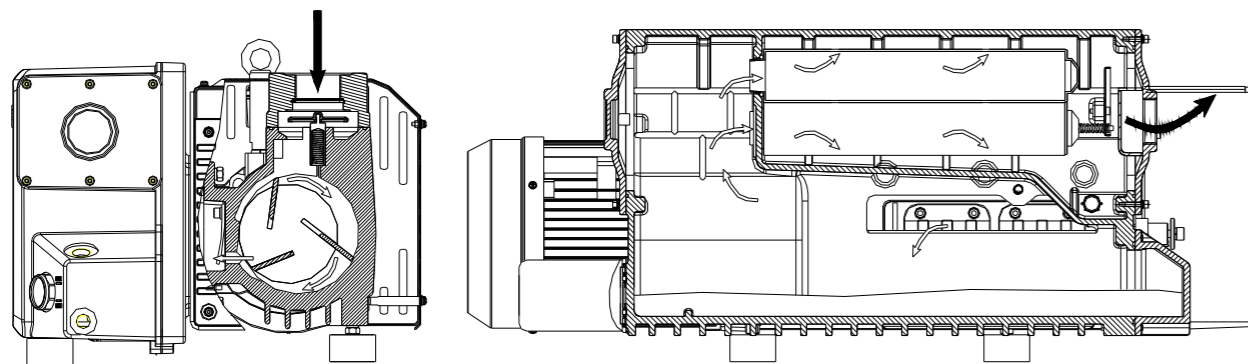

Fig.3

3.1 Principle of Operation

Refer to Fig.3, the rotor, mounted eccentrically in the pump cylinder, has three vanes which divide the pump chamber into several different chambers. When the pump rotor which is driven by the motor rotates, chambers will have periodical change accordingly. The gas is inhaled from the intake port, getting through filter, and anti-suck back valve into the pump chamber, and then enters into the sealed chambers formed by vane and rotor. After suction and compression, the gas comes out from the exhaust valve, getting through the oil mist filter, and finally goes out of the oil casing. Completing continued work cycle from suction, compression and exhaust, the pump achieves the vacuum of the system.

3.2 Principle of Gas Ballast

The controllable gas (generally dry air at room temperature) is admitted into the pump chamber. It is mixed with pumped vapor during the gas compression process. This increases the percentage of non-condensable gas such that the partial pressure of the vapor being pumped is below its saturated vapor pressure when the exhaust valve opens. The vapor is then discharged from the pump without liquefaction. The more vapor contained in the pumped gas, the more dry air is required (See Fig.1 Gas ballast valve).

4. Technical Parameters

	Unit	NRS20	NRS22	NRS28	NRS40	NRS65	NRS100	NRS160	NRS200	NRS300
Pumping speed (50 Hz)	m ³ /h	20	22	28	40	65	100	160	200	300
Ultimate pressure without gas ballast	mbar	≤3x10 ⁻¹					≤8 x10 ⁻²			
Ultimate pressure with gas ballast I	mbar	0.5	1.5	≤5 x 10 ⁻¹						
Ultimate pressure with gas ballast II	mbar			≤2.5	≤2	≤2.5	≤1.5			
Allowing water vapor pressure	Gas ballast I	mbar			≤0.8		≤0.5	≤0.8	≤0.5	
	Gas ballast II	mbar			30			50		
Noise (Lw)	50 Hz	dB	≤65	≤58	≤59	≤61	≤62	≤70	≤71	
Power supply		Single/Three-phase		Three-phase						
Power rating	kW	0.75	1.1	1.1	1.5	2.2	4	5.5		
Motor speed (50/60 Hz)	rpm	3000/3600		1440/1720						
Ambient temperature	°C	10~40								
Oil capacity	l	0.5	1	2.5			5~7		7~9	
Protection class		IP54								
Intake and Exhaust DN		1/2" 3/4"		3/4"	1 1/4"			2"		
Weight	Kg	19.5	30	39.2	42.5	72	132	195		
Dimension (L*W*H)	mm	317x249x219		496x268x248	555x304x268	555x311x268	703x406x286	930x533x436		1035x540x434

Table 1

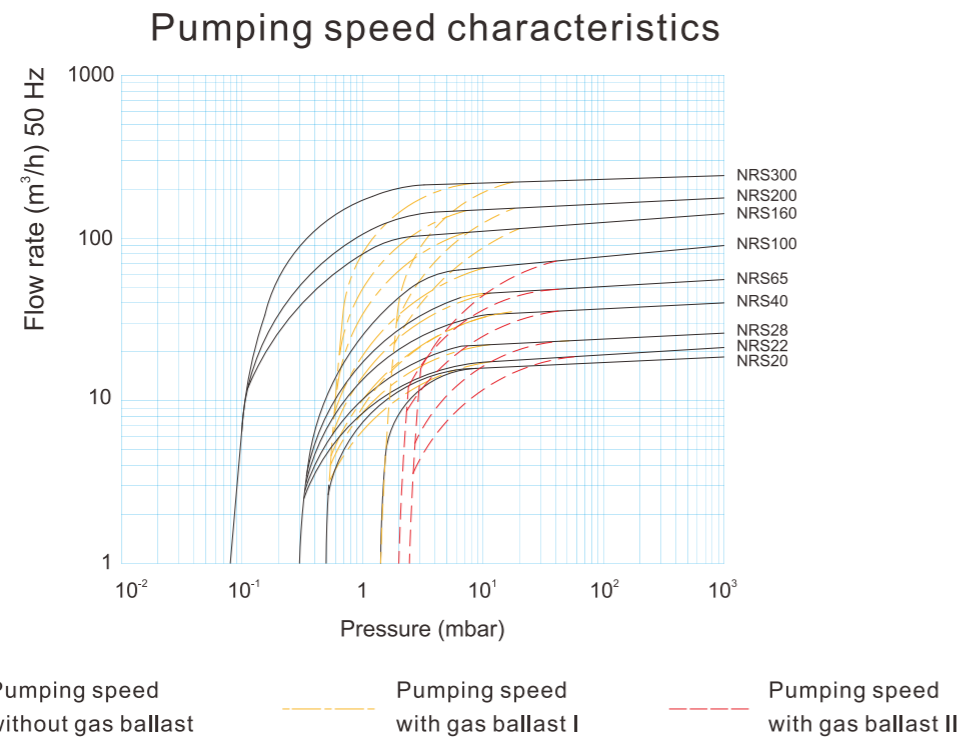

Fig.4

5. Transport and Storage

! Warning

Do not move the pump unless it's switched off and the power supply is disconnected.

! Warning

Make sure that the lifting eye is tightened before lifting the pump (NRS20 is exceptional).

! Notice

Move the pump with care. Any negligence will cause pump damage during transportation. In order to avoid oil spilling, move the pump fully filled with oil in horizontal direction.

! Notice

Handling of used packing material must be in compliance with local environmental laws and regulations.

! Notice

For long term storage, clean the pump and empty the oil inside. Store the pump in a dry place at room temperature.

6. Installation and Connection

6.1 Installation Dimensions

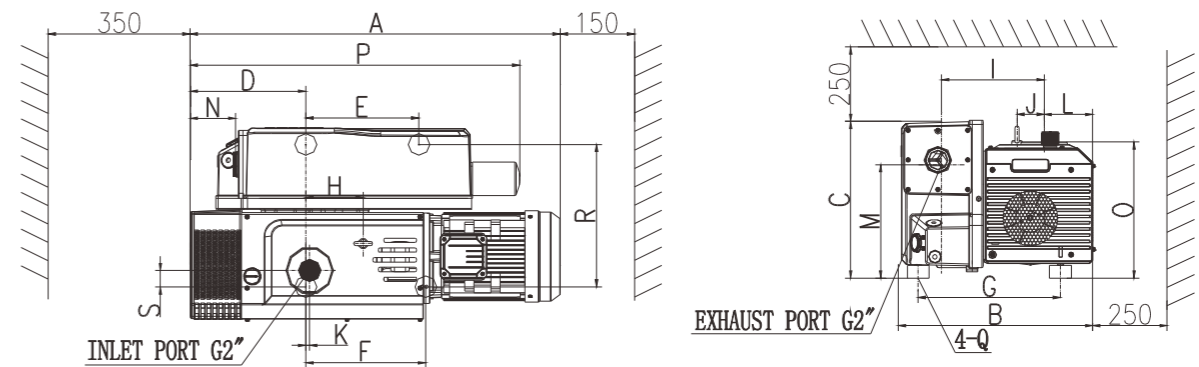

Fig.5

Model	A	B	C	D	E	F	G	H	I	J	K	L	M	N	O	P	Q	R	S	Intake port	Exhaust port
NRS20	317	249	219	72	140	110.5	131	/	127.5	/	14	72	157	17	184	303	M8	125.8	5.3	G1/2" 3/4"	/
NRS22/28	496	268	248	112	220	300	190	108	146	25	20	80	182	27	204	392	M6	194	35	G3/4"	G3/4"
NRS40	555	304	268	149	215	200	235	58	179	51	5	72	203	33	252	464	M10	235	33	G1" 1/4	G1"1/4
NRS65	555	311	268	149	215	200	254	58	189	51	5	72	203	33	252	464	M10	242	33	G1" 1/4	G1"1/4
NRS100	703	406	286	165	225	225	320	131	226	42	27	91	220	61	280	578	M10	258	41	G1" 1/4	G1"1/4
NRS160/200	930	533	436	263	252	305	394	113	298	66	32	135	305	134	382	930	M10	394	45	G2"	G2"
NRS300	1035	540	434	326	313	332	394	159	284	75	11	135	314	132	377	966	M10	394	45	G2"	G2"

Table 2

6.2 Connection to System

! Warning

The pump is strictly forbidden to operate in areas with risk of fire and explosion.

! Warning

Make sure the gas flow at the exhaust port is not blocked or restricted in any way. Check to ensure the exhaust line is not obstructed by deposits before start-up.

! Warning

The exhaust pressure shall not be 1.15 bar higher than the absolute pressure (relative pressure 0.15 bar) but not be lower than atmospheric pressure.

! Notice

Take the following into account to choose the pump installation site: convenient for installation, maintenance, disassembly and electrical connections as well as good ventilation.

! Notice

Place the pump feet horizontally or fix the feet with bolts while connecting the pump to vacuum system.

! Notice

Oblique installation may result in pump's vibration, high noise or even damage. The pump shall be set up on a flat and firm surface.

! Notice

The length of connecting line between pump and vacuum system shall be as short as possible. The diameter of the connecting line shall be the same as that of intake port.

! Notice

The hoop at intake port is available for connection with vacuum hose or regular vacuum pipe. No any stress generated by the pipe on the hoop is allowed while connecting.

! Notice

The exhaust line should be laid so that it slopes down so as to prevent condensate from backstreaming into the pump and contaminating the oil. Drain the oil in the exhaust line periodically to avoid block of exhaust line. If the exhaust line slopes up, the installation of a condensate trap is necessary. Check leak of the connection between pipe and flange. Vacuum tightness is essential for the achievement of ultimate pressure of the pump.

6.3 Power Supply and Motor Rotation Direction

! Warning

Make sure the power supply is correct. The electrical connections must be performed by a skilled electrician according to the technical guidelines and wiring regulations for electrical equipment. For 3-phase motor, open the junction box cover and make the connections according to the wiring diagram refer to Fig. 6. No components are supplied for electrical connections. The extra selected cable and motor protection switch shall have the same rated current value as stated on the motor nameplate.

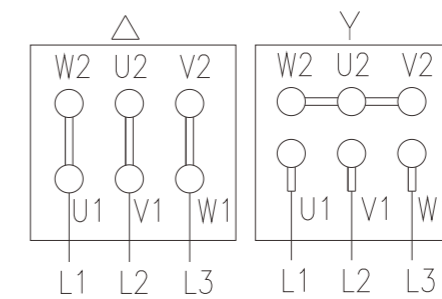

Fig.6 Wiring diagram for 3-phase motor

How to check rotation direction of 3-phase motor:

Check whether the motor rotation direction is the same as the indicated arrow on the motor. In case that an incorrect direction is found, cut off the power immediately and interchange any 2 wires of L1, L2 and L3.

7. Initial Start and Operation

7.1 Start-up

! Warning

Make sure the gas flow at the exhaust port is not blocked or restricted in any way. Do not start the pump if the exhaust port is blocked.

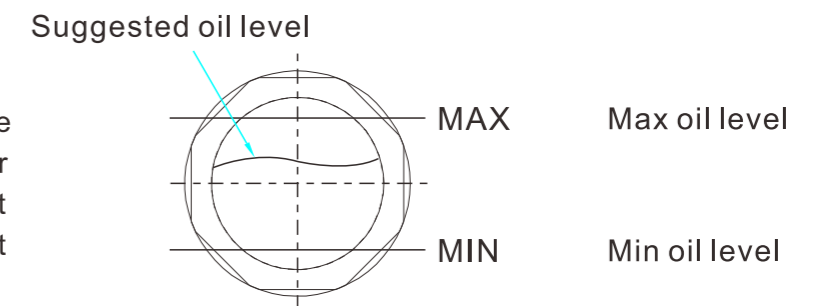

Fig.7

! Warning

The oil level shall be kept between position MAX and MIN of oil sight glass. Excessive or insufficient oil will decrease the pump performance or even cause malfunction. The pump must be stopped before adding oil.

! Notice

The operating ambient temperature is 10 - 40°C and humidity should be less than 85%.

7.2 Operation

Notice

High temperature hazard! Do not touch the surface! The surface of the pump could be very hot during operation and after shutdown within one hour.

Pumping non-condensable gases

Close the gas ballast to pump non-condensable gases (Set the gas ballast to position C, refer to Fig. 1). The ultimate pressure will rise (loss of vacuum) with gas ballast opened.

Pumping condensable gases and vapor

If the vacuum system contains a small amount of condensable gas, open the gas ballast valve (Set the gas ballast to position I or II, refer to Fig. 1) and keep the pump running for at least 30 minutes to pump the condensable gas effectively. Close the gas ballast valve when the vacuum system pressure is reduced to a certain value. If the pump operates at low temperature, condensable gas may be dissolved in the pump oil. The oil may be emulsified or deteriorated which will affect the pump performance, even cause corrosion of the pump body.

The rise of oil level during pump operation is a sign of condensable gas contained in the vacuum system.

Do not switch off the pump immediately when the process is finished. Keep the pump running with gas ballast open and intake port closed until all gases dissolved in the oil are removed.

8. Inspection and Maintenance

Warning

All checks and maintenance must be performed by trained personnel in accordance with local safety rules and regulations.

Warning

In case of presence of hazardous substances due to oil decomposition or media sucked into the pump, it's necessary to define the hazard and take all necessary safety precautions.

Warning

In the presence of hazardous substances, determine the hazard in the first time and follow all appropriate safety procedures. If the potential hazard still exists, the pump must be decontaminated before any maintenance.

8.1 Inspection

Inspection	Period	Remarks
Oil level	Every day	8.2.1
Pump's noise	Every day	8.2.2
First oil change	After 150 hours of operation	8.2.3
Change oil mist filter	After 1500 - 3000 hours of operation or emerging oil fog	8.2.4
Regular checking floating ball components	Six months	8.2.5
Change gas ballast filter cartridge	After 500 - 1500 hours of operation or obstructed	8.2.6
Check anti-suckback oil valve	Six months or loss of vacuum	8.2.7
Clean intake filter	Six months	8.2.7
Change oil filter	After 500 - 1500 hours of operation hours or changing oil	8.2.8
Clean fan cover	Six months	8.2.9
Check connecting wires	Six months	
Drain oil period	After 1500 - 3000 hours of operation or six months	

Table 3

8.2 Maintenance

8.2.1 Check the oil level

- (1) The oil level shall be always kept between position MAX and MIN of oil sight glass during operation (refer to Fig. 7). Add oil when the oil level is lower than position MIN and discharge oil by removing the oil drain plug (refer to Fig. 2) when the oil level is above position MAX.
- (2) Check the oil color. Replace the oil if the color is other than clear and transparent.

8.2.2 Check the pump's noise

The pump noise shall be continuous and stable during operation. If any abnormal noise is found, refer to Table 4 Troubleshooting.

8.2.3 Oil change

- (1) Change the oil when the pump is switched off and cooled down.
- (2) Remove the oil drain plug (Fig. 2) and drain the used oil into a suitable receptacle. When the flow of oil stops, screw on the oil drain plug and start the pump shortly (10 seconds). Switch off the pump, remove the plug again and drain the residual oil. Screw on the oil drain plug (Check O-ring, replace it if necessary). Remove the oil fill plug (Fig. 2) and fill in fresh pump oil which is specified or provided by the manufacturer.
- (3) After oil changing, handle the used oil stored in an assigned container according to local relevant environmental laws and regulations.

8.2.4 Regular checking / changing oil mist filter

- (1) If there is oil fog coming out from exhaust port during operation, the safety valve of oil mist filter must be opened or the filter is failed, and it need to be replaced.
- (2) Only the pump stopped operating and cooled down, could the oil mist filter be replaced.
- (3) Open the cover of exhaust port, take out the oil mist filter, and check the O ring and replace it if needed.

8.2.5 Regular checking floating ball components

Please check the floating ball components together with oil mist filter. Firstly pull up the floating ball components pole, then pull up the floating ball components. Check whether the floating ball components rubber is damaged and clean it in time.

8.2.6 Regular checking / changing gas ballast filter cartridge

Regularly remove the gas ballast rubber cab and observe if there is much dust inside the filter cartridge. Use a wrench or other proper tool to take the filter cartridge out. Replace it if necessary.

8.2.7 Regular checking intake filter and anti-suckback oil valve

Regularly take down the intake port and clean the filter by compressed air. Check the seal position of anti-suckback valve for cleanness, damage, hardening and height.

8.2.8 Regularly check and replace of oil filter

Drain off the oil in the oil filter, screw out the oil filter for a new one, then coat some oil on the seal surface of the filter, finally turn on by hand.

8.2.9 Regularly check fan cover and motor fan

Regularly remove the clean the fan cover and motor fan. Clean them by compressed air and reinstall them properly before pump operation.

9. Troubleshooting

Fault	Possible reason	Remedy
Pump cannot start	1. Wiring is malfunctioning.	1. Check and repair wiring.
	2. Operation voltage is abnormal.	2. Make sure the voltage is within rated voltage's tolerance of $\pm 10\%$.
	3. Motor is malfunctioning.	3. Replace the motor.
	4. Overload protector is active.	4. Check the ambient temperature or pumped gases temperature.
	5. Oil temperature is below 10°C	5. Increase the ambient temperature.
	6. Pump is jammed.	6. Repair the pump.
	7. Out of operating for long.	7. Repair the pump.
	8. Oil is too viscous.	8. Change the oil.
	9. Exhaust filter or exhaust line is clogged.	9. Replace the filter or clean the exhaust line.
	10. Pump inner parts are damaged.	10. Repair the pump.
Pump cannot reach ultimate pressure.	1. Vacuum system configuration is unreasonable.	1. Choose a suitable pump.
	2. Vacuum system leak.	2. Check the system.
	3. Measuring technique or gauge is unsuitable.	3. Use correct measuring technique and gauge. Measure the pressure directly at pump's intake port.
	4. Poor lubrication.	
	4.1 Oil filter is obstructed.	4.1 Change the oil filter.
	4.2 Oil is unsuitable.	4.2 Change the oil.
	4.3 Oil channel is obstructed.	4.3 Clean the channel.
	4.4 Oil is insufficient.	4.4 Add the oil to the level as requested.
5. Anti-suckback oil valve is malfunctioning.	5. Repair anti-suckback oil valve.	
6. Intake line is dirty.	6. Clean vacuum lines.	
7. Floating ball components return oil valve is malfunctioning.	7. Repair floating ball components return oil valve.	
Pumping speed is too low.	1. Intake port line is clogged.	1. Clean the intake port line.
	2. Connecting lines are too narrow or too long.	2. Use adequately wide and short connecting lines.
	3. Exhaust line is clogged.	3. Keep exhaust port line unobstructed.
	4. Oil mist filter is clogged.	4. Change the oil mist filter.
	5. Anti-suckback oil valve is malfunctioning.	5. Repair anti-suckback oil valve.
Noise is abnormal.	1. Operation voltage is abnormal.	1.1 Check the power supply, switches and wiring connection. 1.2 Make sure the voltage is within rated voltage's tolerance of $\pm 10\%$.
	2. Foreign matters entering into the pump.	2. Repair the pump.
	3. The oil level of the pump is too low.	3. Add the oil to the level as requested.
	4. The pump inner parts are damaged.	4. Disassembly and replace the parts.

Fault	Possible reason	Remedy
Pump gets hotter than usually observed.	1. Poor ventilation.	1. Improve ventilation environment.
	2. The fan is damaged.	2. Change the fan.
	3. Pumped gas temperature is too high.	3. Add cold trap at intake port.
	4. Poor lubrication.	
	4.1 The oil filter or exhaust line is clogged.	4.1 Replace oil filter or clean the exhaust line.
	4.2 Oil is unsuitable.	4.2 Change the oil.
	4.3 Oil channel is obstructed.	4.3 Clean the channel.
	4.4 Oil is insufficient.	4.4 Add the oil to the level as requested.
	5. The condensator is dirty.	5. Clean the condensator.
Oil in the intake line or in vacuum vessel.	6. Ambient temperature is too high.	6. Reduce ambient temperature.
	1. Oil comes from the vacuum system.	1. Check the vacuum system.
	2. Anti-suckback valve spring is obstructed.	2. Replace anti-suckback valve spring.
	3. Anti-suckback valve plate is obstructed.	3. Replace anti-suckback valve plate.
Vacuum pressure in system rises too fast when pump stops.	4. Oil level is high.	4. Drain the excess oil.
	1. Vacuum system leak.	1. Check the system.
Too much oil in the exhaust port.	2. Anti-suckback valve is malfunctioning.	2. Repair anti-suckback valve.
	1. Too much oil in the pump.	1. Drain some oil.
	2. Continuous operation under high pressure in the intake port.	2. Shorten exhaust time.
Sealing surface leak	3. Oil mist filter is obstructed.	3. Replace oil mist filter.
	1. The seal is damaged.	1. Replace the seal.
	2. Seal ring is damaged.	2. Replace the seal ring.

Table 4

10. Warranty

NRS series vacuum pumps have one year guarantee from the date of purchase. Spare parts will be provided free of charge within the period of guarantee in condition that the pump is operated according to the operating manual. The following failures will be charged for repair:

- (1) Malfunction caused by nature disasters or artificial factors.
- (2) Malfunction caused by special operating environment.
- (3) Damage of wear parts.
- (4) Malfunction caused by abnormal operation or incorrect use identified by our engineers.

Before the pump is delivered to our company for maintenance, it is required to acquire the information if the pump is contaminated (and which kind of pollutants) or hazardous substances exist inside the pump. Without receiving this statement in advance, the pump will be returned to the address of the sender.

11. Accessories

To ensure the stability of the pump, please use the accessories we provided. Please offer the pump item number and code of spare parts while purchasing. Below is the diagram for optional accessories, if you have any other request, please contact us.

What we provide as accessories is as following:

- 1. Spare parts (see spare parts list)
- 2. Other type of intake port /exhaust port
- 3. Dust filter