

MFL205

Fuse Finder

INSTRUCTION MANUAL

MFL205 Fuse Finder

This document is copyright of:

Megger Limited, Archcliffe Road, Dover, Kent CT17 9EN. ENGLAND

T +44 (0)1304 502101 F +44 (0)1304 207342 www.megger.com

Megger Ltd reserves the right to alter the specification of its products from time to time without notice. Although every effort is made to ensure the accuracy of the information contained within this document, it is not warranted or represented by Megger Ltd to be a complete and up to date description.

This manual supersedes all previous issues of the manual. Please ensure that you are using the most recent issue of this document. Destroy any copies that are of an older issue

Safety Information

Understand and follow the operating instructions carefully

WARNING

Identify hazardous conditions and actions that could cause BODILY HARM or DEATH

When using test leads or probes, keep your fingers behind the finger guards

Personal protective equipment should be used if there are ACCESSIBLE HAZARDOUS LIVE PARTS in the installation where measurement is to be carried out

Use the meter only as specified in this manual otherwise, the protection provided by the meter may be impaired

Verify the instruments correct operation before each use

Do not apply more than the rated voltage, as marked on the meter, between the terminals or between any terminal and earth

Use caution with voltages above 30 V AC rms, 42 V AC peak, or 60 V DC. These voltages pose a shock hazard

Do not use the meter around explosive gas or vapor

To reduce the risk of fire or electric shock do not expose this product to rain or moisture

Lead, probe and clip assemblies to be used for MAINS measurements shall be RATED as appropriate for MEASUREMENT CATEGORY III or IV, according to EN 61010- 03, 1 and shall have a voltage RATING of at least the voltage of the circuit to be measured

DO NOT USE if the internal white insulation layer of the test leads is exposed

DO NOT USE the test leads, probes or clips above the maximum ratings of CAT Environment or voltage that are indicated each component

Do not apply or remove the test leads on or around uninsulated hazardous live conductors, where a potential to cause electric shock, electrical burns or arc flash exists

CAUTION

1. The Megger MFL205 is designed to be used by suitably qualified or competent people who are familiar with the electrical installation they are connecting to
2. All safety warnings within this manual must be read and understood before use of the MFL205. Failure to comply may lead to serious injury or damage to the installation or meter
3. If possible, the system should be powered down when connections are made or removed
4. Always connect the black (negative) test lead before the red (live) test lead. The red lead should always be removed before the black lead
5. The transmitter and receiver are designed for indoor use only and should not be used outside or in damp or wet environments
6. Before use, always prove the meter is functioning correctly, as described in this manual
7. Do not expose the meter to extremes of temperature or high humidity

Symbols as marked on the Meter and Instruction manual



Risk of electric shock



Equipment protected by double or reinforced insulation



Conforms to EU directives



Conforms to UKCA directives



Do not discard this product or throw away

CATIII

Measurement category III: Equipment connected between the consumer unit and the electrical outlets.

CATII

Measurement category II: Equipment connected between the electrical outlets and the user's equipment.

Unpacking and Inspection

Megger MFL205 Transmitter

Megger MFL205 Receiver

Crocodile Clips (one black, one red)

User Manual

Carry case

Battery

Optional Accessories

Megger MSA1363 – UK BS1363 Socket Adapter

Megger MTF230 – Type F (Schuko) Socket Adapter

MFL205 Fuse Finder

Meter Description

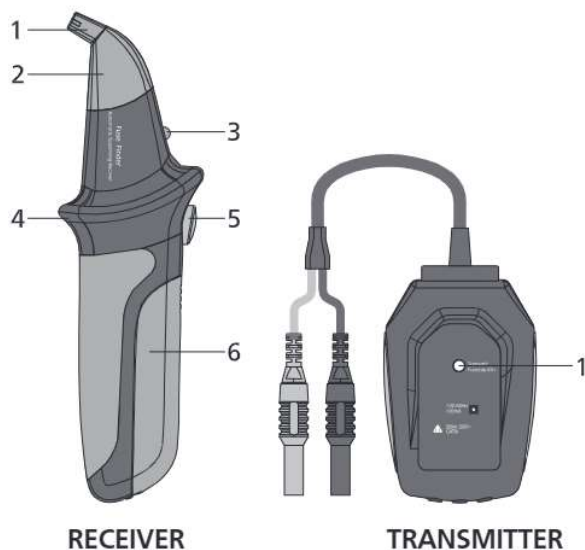

Receiver

1. Scanning Probe
2. LED Indicator
3. Signal LED Indicator
4. Buzzer
5. ON/OFF/RESET Button
6. Battery Cover

Transmitter

1. Power Indicator light

Transmitter

There is no power switch on the transmitter. Injection of the test signal will automatically start upon connection to the mains supply (110/230 V 50/60 Hz)

Receiver

The button on the receiver has 3 functions: ON/OFF/RESET

To turn on, press and release the ON/OFF/RESET button. LED indicator (2) will light and glow red and the receiver will start beeping

To reset, with the receiver switched on, push and immediately release the ON/OFF/RESET button. This will reset the scanning function memories to zero and should be carried out with the receiver held away from the distribution board/ cables being scanned

To power down, press and hold down the ON/OFF/RESET button for longer than 1 second

NOTE: To conserve battery, the receiver will automatically power down after 3 minutes of inactivity. To resume scanning, press the ON/OFF/RESET button as detailed above

Function Check

Before using the MFL205, the following function check should be performed. First, turn on the receiver and check that the LED is red and a steady beeping tone is emitted. If either of these functions are not operating, replace the battery and re-check

A low battery indication is given if the LED is green and the beeps emitted are longer in duration. This indicates >20% battery life remains and the battery should be replaced as soon as possible

Connect the transmitter and turn on the supply. Move the scanning probe of the receiver over the housing of the transmitter

The beeping from the receiver should become very rapid, or change to a continuous tone, and the LED should turn green.

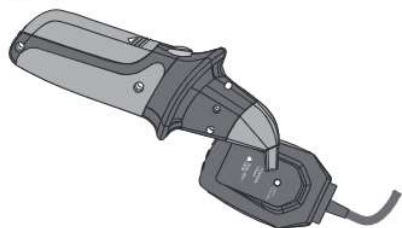

Performing the "Function Check"

Operating Instructions

1. Perform the function check, as described above
2. At the distribution board or consumer unit, place the scanning probe in contact with the face of the circuit breaker or fuse carrier at a right angle to the direction of the breaker/carrier body. Run the scanning probe steadily along the row of breakers/fuses. The frequency of the beeping will increase and become very rapid or continuous and the LED will turn from red to green when it encounters a stronger signal
3. Continue to scan across the rest of the breakers/fuses
4. If the receiver led starts to flash red, remove the scanning probe, press the reset button and start the process again

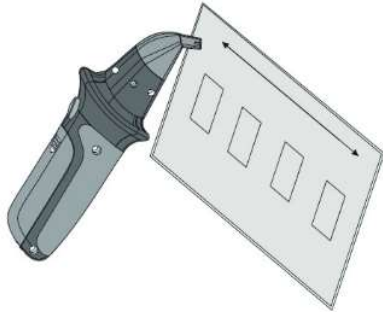

Scanning the breakers of fuses

NOTE: The first strong signal you encounter may not be the strongest signal there is. Do not stop scanning as the technology used is comparative and it is essential that all breakers and fuses are scanned to ensure the strongest signal is indicated

5. Repeat the process. With each scan, the receiver automatically adjusts the sensitivity to disregard any weaker signals.
6. Continue scanning until only one breaker causes the rapid/continuous beeping and the LED turns green. This is the breaker protecting the circuit the transmitter is connected to
7. Isolate this circuit and the receiver will revert to a red LED and steady beep
8. Confirm the correct breaker/Fuse has been isolated by checking the power light on the transmitter is extinguished
9. Prior to undertaking any work, a safe isolation test should then be performed on the circuit using a suitable 2-pole tester and proving unit

Alternative scanning options

Due to the different designs of circuit breakers it may be unclear using the above method which of two breakers is emitting the stronger signal, particularly if it appears to be from an area between two adjacent breakers. In the event of this happening, using one of the two methods below should aid pinpoint identification of the correct breaker

1. Reset the receiver and scan the breakers on the opposite side of the switch

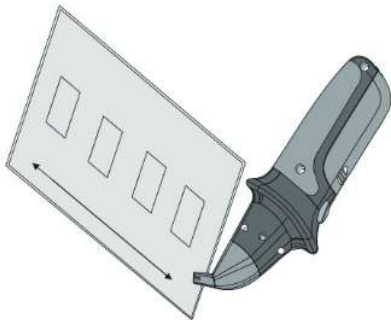

Scanning opposite side of the breaker or fuses

2. Reset the receiver and rotate it through 90° and scan one side of the breaker
3. If the signal is still not clear, reset again and scan the opposite side of the breaker with the receiver still held at 90°

MFL205 Fuse Finder

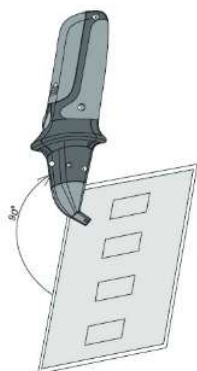

Scanning the breaker or fuses with the receiver at 90°

Best practice

1. Do not let the scanning probe wander around as this will affect the automatic scanning memory
Keep the scanning probe in contact and at the same angle to the breakers during each pass to ensure consistency in the readings
2. Scan only one side of the breaker on each pass
3. Ensure the receiver is removed from the distribution board and reset before changing any of the test parameters

NOTE: Some fluorescent lighting may cause inconsistent amplification of the injected signal and “ghost” signals to appear on other circuits. This is usually seen on split distribution boards

Battery Replacement

The MFL205 Receiver is powered by a single 9 V battery.

Low battery voltage is indicated by the beeping tone of the receiver having a longer duration. The warning activates when the battery capacity drops below 20%. The battery should be replaced as soon as possible to ensure continued, correct operation

To replace the battery, remove the battery cover retaining screw. Slide the cover off to gain access to the battery compartment. Fit the 9 V battery, taking care to observe correct polarity. Replace the battery cover and replace the battery cover retaining screw

Maintenance

Do not attempt to repair either the transmitter or receiver. They contain no user-serviceable parts. Repair or servicing should only be performed by qualified personnel

Cleaning

Periodically wipe the case of both the transmitter and receiver with a damp cloth. Do not use abrasives or solvents. Ensure both are dry before further use

Battery Disposal

The batteries in this product are classified as Portable Batteries under the Batteries Directive. Please contact either Megger Ltd, your local Megger office or distributor for instructions on the safe disposal of these batteries

WEEE Directive

The crossed out wheeled bin symbol on the instrument and on the batteries is a reminder not to dispose of them with general waste at the end of their life

Megger is registered in the UK as a Producer of Electrical and Electronic equipment. The registration No is; WEE/ DJ2235XR. Users of Megger products in the UK may dispose of them at the end of their useful life by contacting B2B Compliance at www.b2bcompliance.org.uk or by telephone on 01691 676124

Users of Megger products in other regions should contact their local Megger office or distributor

Product manufactured in China

Specification

Operating Voltage	110/230 V 50/60 Hz
Current consumption	< 20 mA
Auto power off (Receiver)	3 minutes of inactivity
Operating temperature	0° to 40°C (32°F to 104°F)
Storage temperature	0° to 50°C (32°F to 122°F) at < 95% RH
Relative humidity	95% (0° to 30°C)
Operating altitude	≤2000 M
Power supply	1 x 9 V PP3 alkaline (receiver)
Battery life	>40 hours
IP Rating	IP50
Safety	EN61010-1 CAT III 300 V
EMC	EN61326-1, EN61326-2
Dimensions (H x W x D)	210 x 145 x 60 mm (Tx:100 x 65 x 30) (Rx:198 x 58 x 36)
Kit Weight (Excluding battery)	305g (Transmitter 110g & Receiver 95g)

Warranty

This meter is warranted to the original purchaser against defects in material and workmanship for 3 year from the date of purchase

During this warranty period, the manufacturer will, at its option, replace or repair the defective unit, subject to verification of the defect or malfunction

This warranty does not cover fuses, disposable batteries, or damage from abuse, neglect, accident, unauthorised repair, alteration, contamination, or abnormal conditions of operation or handling

Any implied warranties arising out of the sale of this product, including but not limited to implied warranties of merchantability and fitness for a particular purpose, are limited to the above. The manufacturer shall not be liable for loss of use of the instrument or other incidental or consequential damages, expenses, or economic loss, or for any claim or claims for such damage, expense or economic loss. Some states or countries laws vary, so the above limitations or exclusions may not apply to you

Megger Limited Archcliffe Road Dover Kent CT17 9EN

Tel: +44 (0) 1304 502 101 Fax: +44 (0) 1304 207 342 www.megger.com

Manufacturing sites

Megger Limited
Archcliffe Road
Dover
Kent
CT17 9EN
ENGLAND
T. +44 (0)1 304 502101
F. +44 (0)1 304 207342

Megger GmbH
Weststraße 59
52074
Aachen
Germany
T. +49 (0) 241 91380 500
E. info@megger.de

Megger USA - Valley Forge
Valley Forge Corporate Center
2621 Van Buren Avenue
Norristown
Pennsylvania, 19403
USA
T. 1-610 676 8500
F. 1-610-676-8610

Megger USA - Dallas
4545 West Davis Street
Dallas
75211-3422
T. +1 214 333 3201
F. +1 214 331 7399
USSales@megger.com

Megger AB
Rinkebyvägen 19, Box 724,
SE-182 17
DANDERYD
T. 08 510 195 00
E. seinfo@megger.com

Megger Baker
4812 McMurry Avenue
80525
USA
T. +1 970-282-1200
E. baker.sales@megger.com

The company reserves the right to change the specification or design without prior notice.

Megger is a registered trademark

The Bluetooth[®] word mark and logos are registered trademarks owned by Bluetooth SIG, Inc and is used under licence.

Part No: MFL205_UG_en_V01