



## DPM1000

Power Clamp Meter

*User Guide*

Register →  
[megger.com/register](https://megger.com/register)



Support →  
[megger.com/support](https://megger.com/support)





## Safety Information

---

Understand and follow the operating instructions carefully.



### WARNING

---

Identify hazardous conditions and actions that could cause **BODILY HARM** or **DEATH**

- When using test leads or probes, keep your fingers behind the finger guards.
- Personal protective equipment should be used if there are **ACCESSIBLE HAZARDOUS LIVE PARTS** in the installation where measurement is to be carried out.
- Remove test leads from meter before opening the battery door or meter case.
- Use the meter only as specified in this manual; otherwise, the protection provided by the meter may be impaired.
- Always use the proper input terminals, switch position, and range for measurements.
- Verify the meters operation by measuring a known voltage. If in doubt, have the meter calibrated.
- Do not apply more than the rated voltage, as marked on the meter, between terminals or between any terminal and earth.
- Use caution with voltages above 30 V AC rms, 42 V AC peak, or 60 V DC. These voltages pose a shock hazard.
- To avoid false readings that can lead to electric shock and injury, replace the battery as soon as the low battery indicator blinks.
- Disconnect circuit power and discharge all high-voltage capacitors before testing resistance, continuity, diodes, or capacitance.
- Do not use the meter around explosive gas or vapour.
- To reduce the risk of fire or electric shock do not expose this product to rain or moisture.
- Probe assemblies to be used for **MAINS** measurements shall be **RATED** as appropriate for **MEASUREMENT CATEGORY III** or **IV** according to EN 61010-031 and shall have a **voltage RATING** of at least the voltage of the circuit to be measured.
- **DO NOT USE** the test leads if the internal white insulation layer is exposed.
- **DO NOT USE** the test leads above maximum ratings of **CAT Environment** or voltage and current that are indicated on the probe and probe tip guard.
- Do not apply a current with a frequency that is higher than the frequency response range specified in the Electrical Specifications section.
- Do not apply or remove the clamp or test leads on or around uninsulated hazardous live conductors where a potential to cause electric shock, electrical burns or arc flash exists.



## CAUTION

---

Disconnect the test leads from the test points before changing the position of the function rotary switch.

Never connect a source of voltage with the function rotary switch in  $\Omega$ ,  $\overline{\text{H}}$ , and  $\text{temp}$  position.

Do not expose meter to extremes of temperature or high humidity.

Symbols as marked on the Meter and Instruction manual



**Risk of electric shock**



**See instruction manual**



**DC measurement**



**Both direct and alternating current**



**Equipment protected by double or reinforced insulation**



**AC Measurement using FCT3450 flexible CT accessory**



**Battery**



**Earth**



**AC measurement**



**Bluetooth**



**Conforms to EU directives**



**Application around and removal from hazardous live conductors is permitted**



**Do not discard this product or throw away.**

## CATIV

Measurement category IV: Equipment connected between the origin of the low-voltage mains supply outside the building and the consumer unit.

## CATIII

Measurement category III: Equipment connected between the consumer unit and the electrical outlets.

## CATII

Measurement category II: Equipment connected between the electrical outlets and the user's equipment.

## Unsafe voltage

---

To alert you to the presence of a potentially hazardous voltage, when the tester detects a voltage  $\leq 30$  V or a voltage overload (OL) in V, the ⚡ symbol is displayed.

## Features

---

- 10000 Count digital display
- Active backlight with large scale display
- VoltSeek (Non-contact voltage detection)
- Analog bar graph
- True RMS reading on AC and AC+DC mode
- Memory Save/Load (up to 1000 records)
- Data logger (up to 9999 sample values)
- Bluetooth communication
- Torch turns on when clamp jaws open
- Auto selecting 1000 A AC/DC current measurement
- Auto selecting 1000 V AC/DC voltage measurement
- AC current measurement up to 3000 A using FCT3450 flexible CT accessory
- 100 k $\Omega$  Resistance measurement
- Continuity beeper
- Frequency counter
- Power and power factor measurement
- Total harmonics distortion
- Harmonics measurement: 1st to 25th
- Capacitance capability
- °C/°F Temperature function

- Inrush current
- DCA auto-zeroing button
- Peak hold
- Max/Min hold
- Smart data hold
- Phase rotation
- High frequency noise rejection filter
- Auto power off (APO)
- CAT IV 600 V/CAT III 1000 V safety standard

## Unpacking and inspection

---

Upon removing your new Power Clamp Meter from its packing, you should have the following items:

1. Megger DPM1000 Power Clamp Meter
2. Test lead set (one black, one red)
3. Test probes (one black, one red)
4. Crocodile clips (one black, one red)
5. TP100 Temperature probe
6. User Manual
7. Carry case
8. Batteries

## The Meter Description

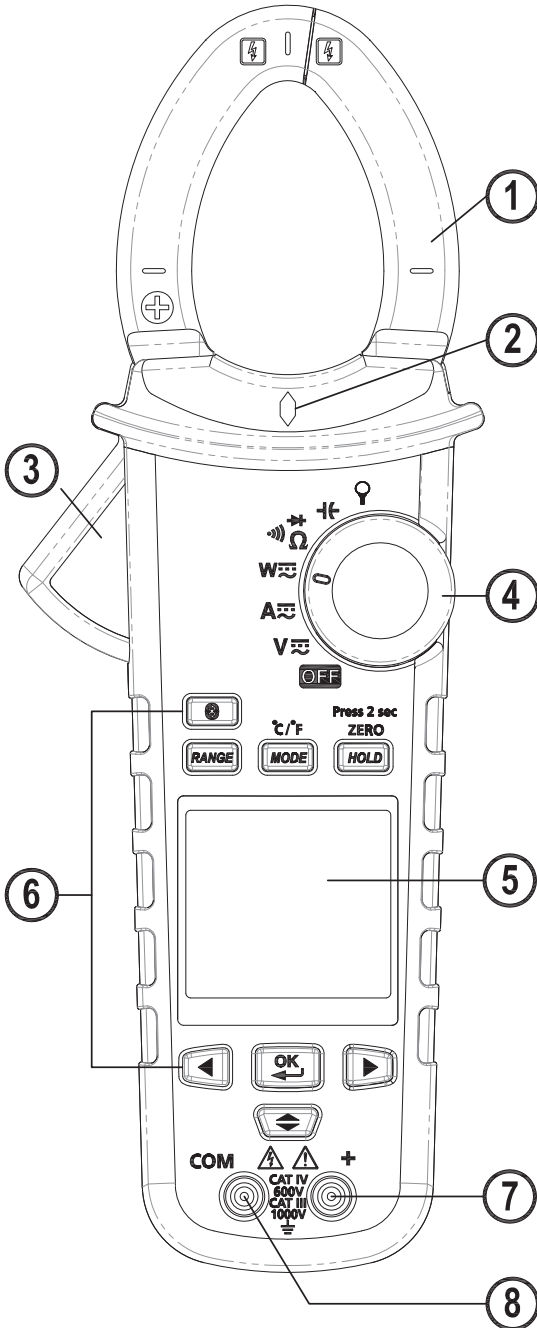

1. Jaw
2. VoltSeek LED
3. Jaw trigger
4. Rotary function switch
5. LCD display
6. Function / Operation push buttons
7. + input terminal
8. Common input terminal

## Power On / Off

---

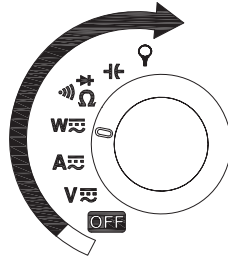
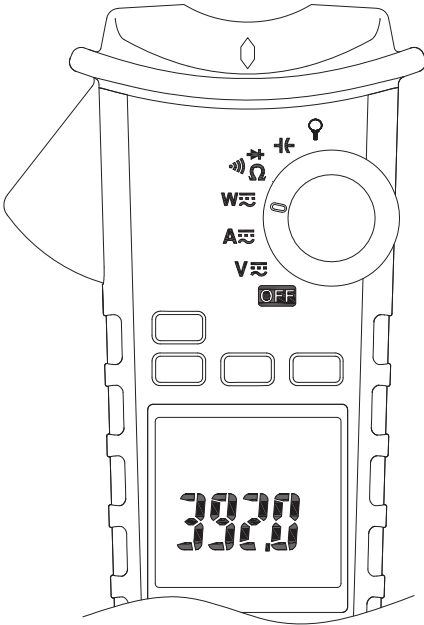

After turning on the meter, the LCD will show Full, hAlf, and Lo to indicate the battery capacity.

## Auto Power Off

---

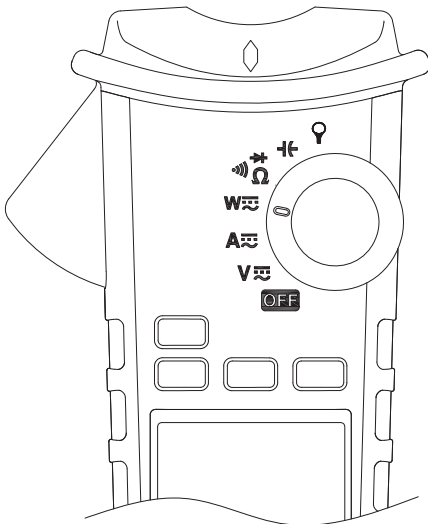

After 15 minutes of no activity

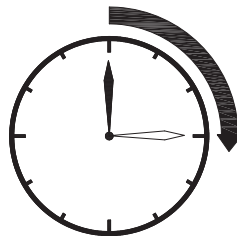

The meter can operate again by turning it on from the OFF position.

## Auto Power Off (APO) disable:

---

Press OK button while turning meter on from the OFF position.

### Push Buttons

#### Bluetooth

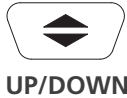

### Menu Operation

---



**MMA Hz HER   MEM LOG**  
**A-SAVE SAVE LOAD CLR RATE**

---



## Example

---

	Use Arrow keys to move the blinking cursor to the target icon, and then press OK button
	Use Arrow keys to move the blinking cursor to the target icon, and then press OK button for more than 2 sec.
<b>MMA</b>	The icon without an underline means the function is not selected.
<b><u>MMA</u></b>	The icon with an underline means the function is selected.

## Making basic measurements

---

### Preparation and Caution Before Measurement

: **Observe the rules of**  **Warnings** and  **Cautions**

The figures on the following pages show how to make basic measurements.

When connecting the test leads to the **DUT** (Device Under Test) connect the common test lead before connecting the live test lead. When removing the test leads, remove the live test lead before removing the common test lead.

## Measuring voltage

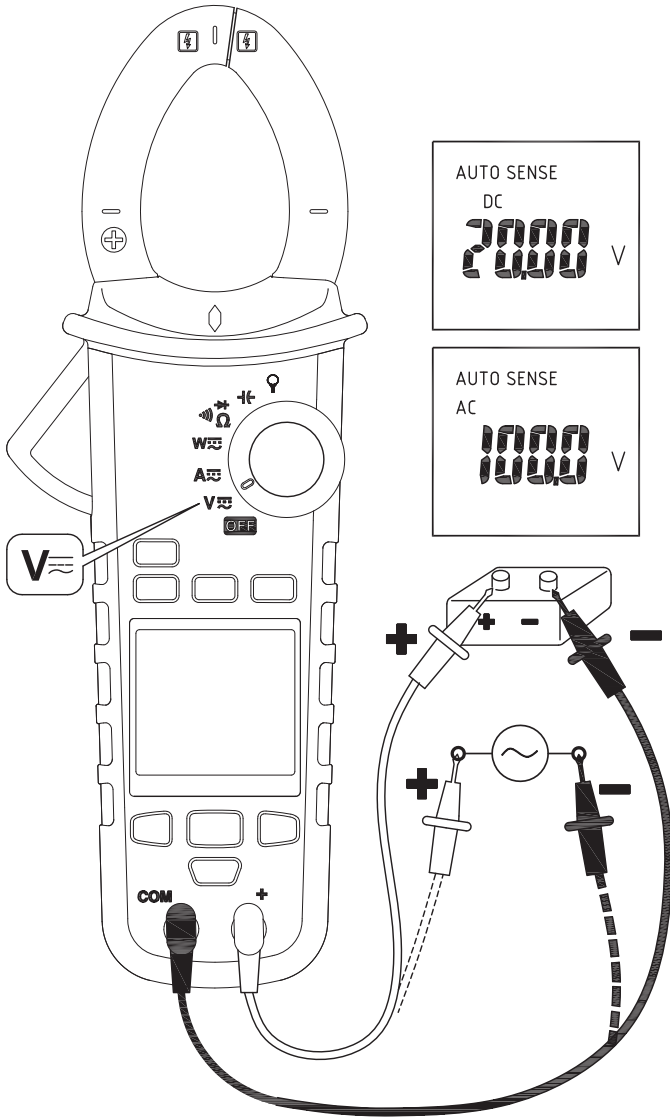

### Warning

To avoid an electrical shock, hazard or damage to the meter, do not attempt a measurement that might exceed 1000 V DC or AC RMS.

## Measuring current

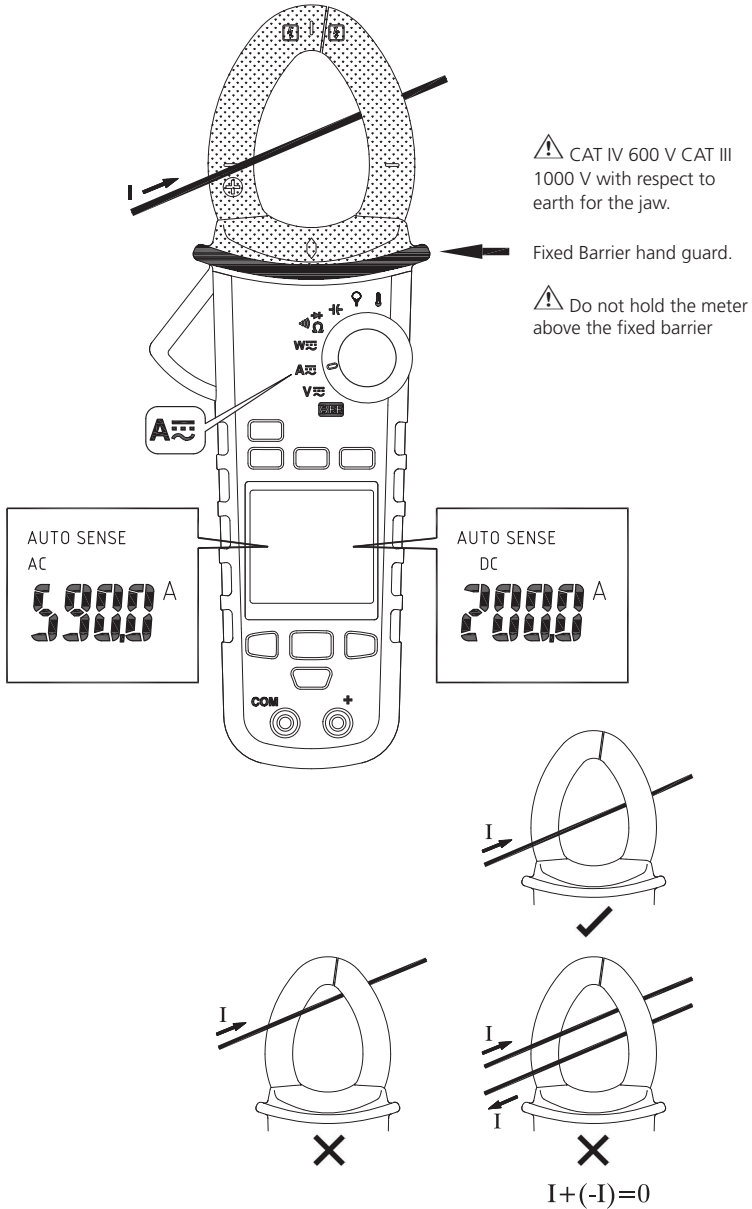

- The torch turns on when the clamp jaws open.
- Do not clamp round a conductor when the meter is powering up

## Measuring AC Currents with the FCT3450 Flexible CT

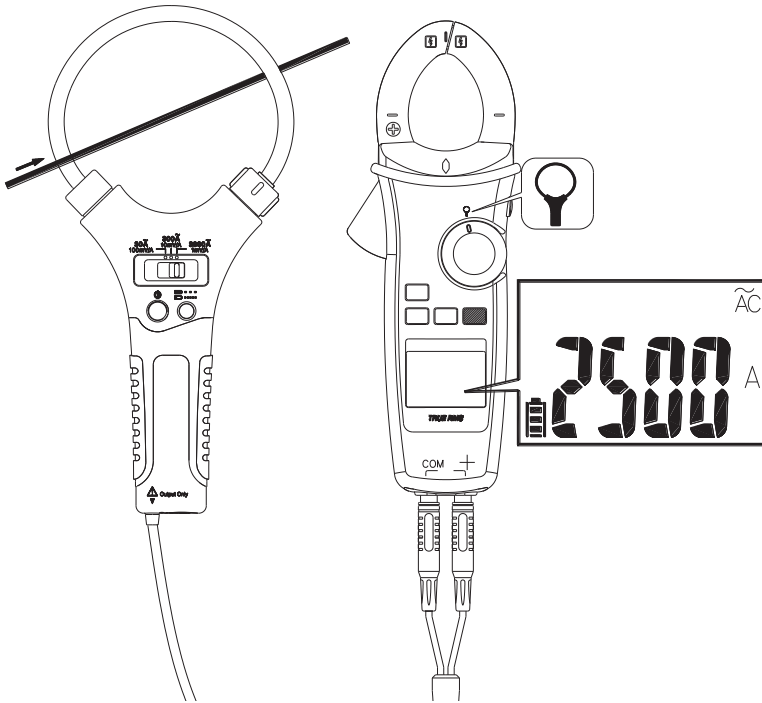

Set the flexible CT input on the rotary switch on the clamp. Set the FCT3450 range selector to 3000 A/1 mV/A

**Note:** Please follow the above illustrated instructions and measure a known current to ensure that the connection between the two meters is correct.

## AUTO SENSE mode:

Displays measurement result for AC only with RMS value or DC value, it depends on whichever is greater.

**AC mode:** AC only with RMS value.

**DC mode:** DC value.

**AC+DC mode:** AC+DC RMS value.

**Note** Press MODE button to enter the AC/DC/AC+DC mode.

Press MODE button for more than 2 seconds to return to the AUTO SENSE mode.

## PEAK HOLD (AC mode only)

### ACV mode

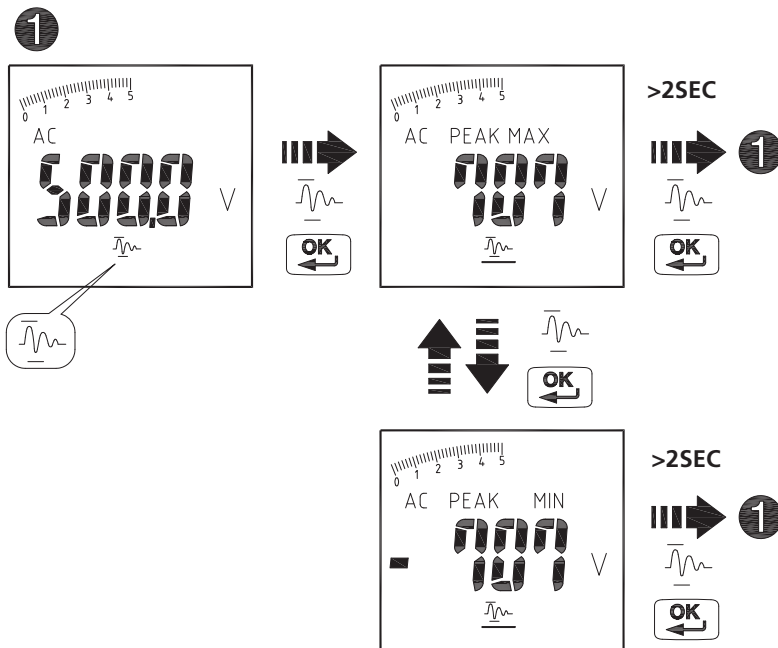

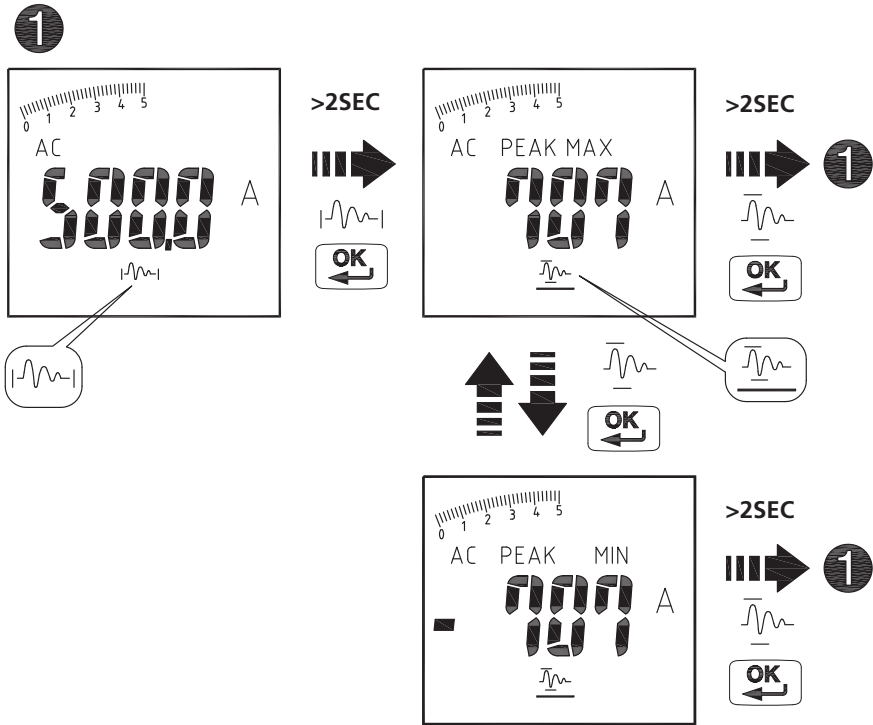

In PEAK HOLD mode, the meter will save the positive peak value and negative peak value. Positive peak value is displayed in PEAK MAX mode. Negative peak value is displayed in PEAK MIN mode.

## Inrush current : (AC mode only)

If the measured inrush current could be greater than 100 A AC, please set the range to 1000 A prior to activating inrush current.

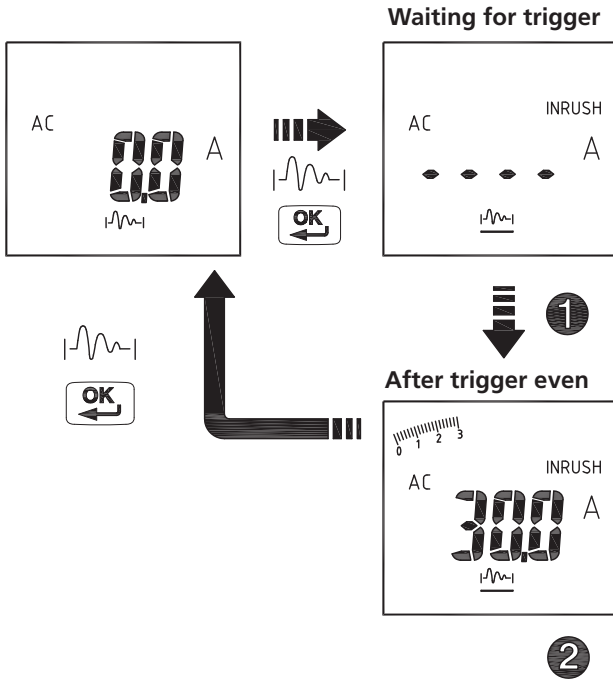
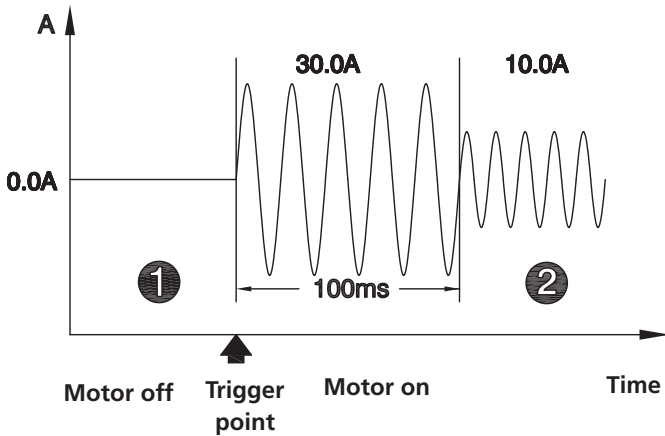

## DCA ZERO

---

Remove the clamp away from the conductor.

Press the HOLD Key > 2 seconds to compensate for any residual magnetism.

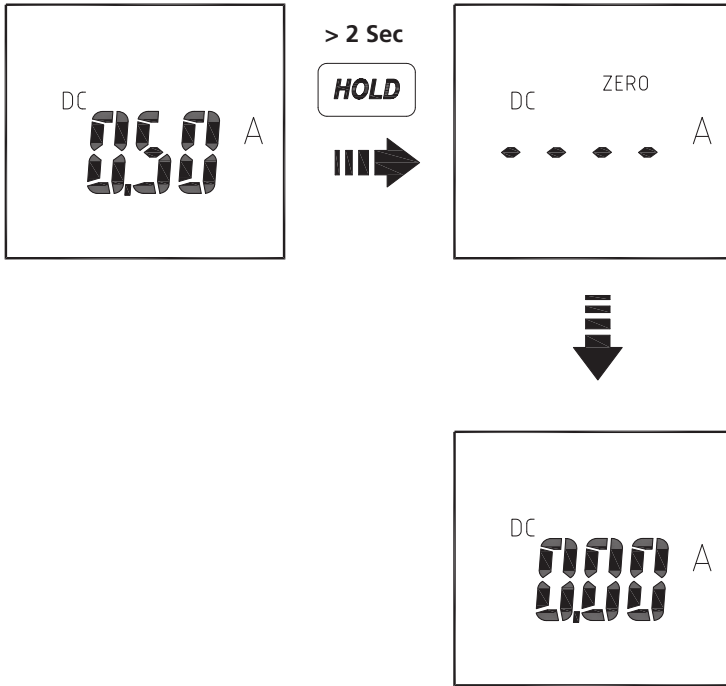

- DCA Zero is available in Auto Sense, DC and AC+DC modes.

## Measuring Frequency (AC mode only)

---

Select the "Hz" icon then press the OK button to enter/exit the frequency measurement mode.

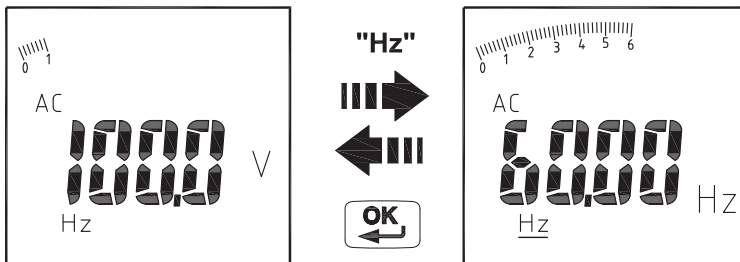



# MAX/MIN/AVG (MMA)

The MAX/MIN/AVG mode records the minimum and maximum input values. When the inputs go below the recorded minimum value or above the recorded maximum value, the meter records the new value. The MAX/MIN/AVG mode can also calculate the average of the readings.

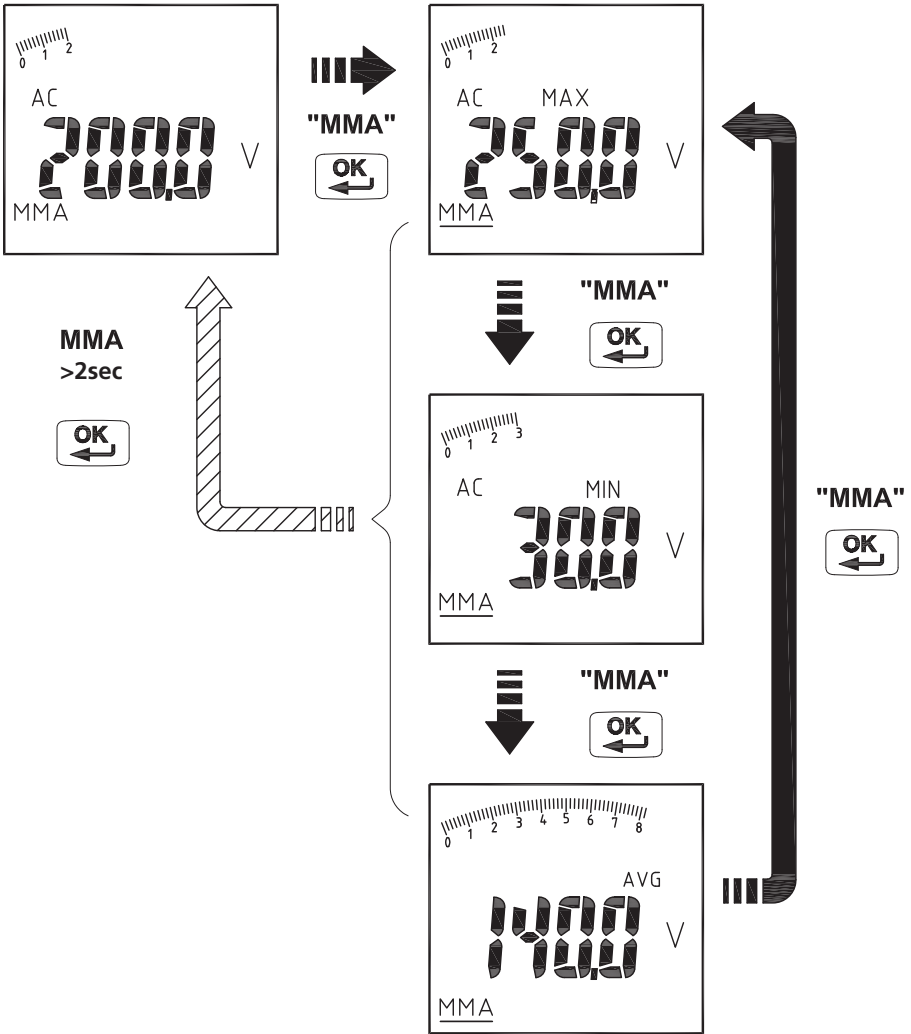

**NOTE:** Press the HOLD key in Max/Min/AVG mode to stop the meter updating the maximum, minimum and average values. HOLD mode must be turned off to continue updating values.

## Harmonic measurement ( AC mode only)

$THD-F = \text{RMS of Harmonics} \div \text{RMS of fundamental} \times 100\%$ .

(harmonics up to the 25th)

$H_n = \text{RMS of Individual Harmonic} \div \text{RMS of fundamental} \times 100\%$ .

Press RANGE button to display harmonic order or the value of the harmonic (unit: %).

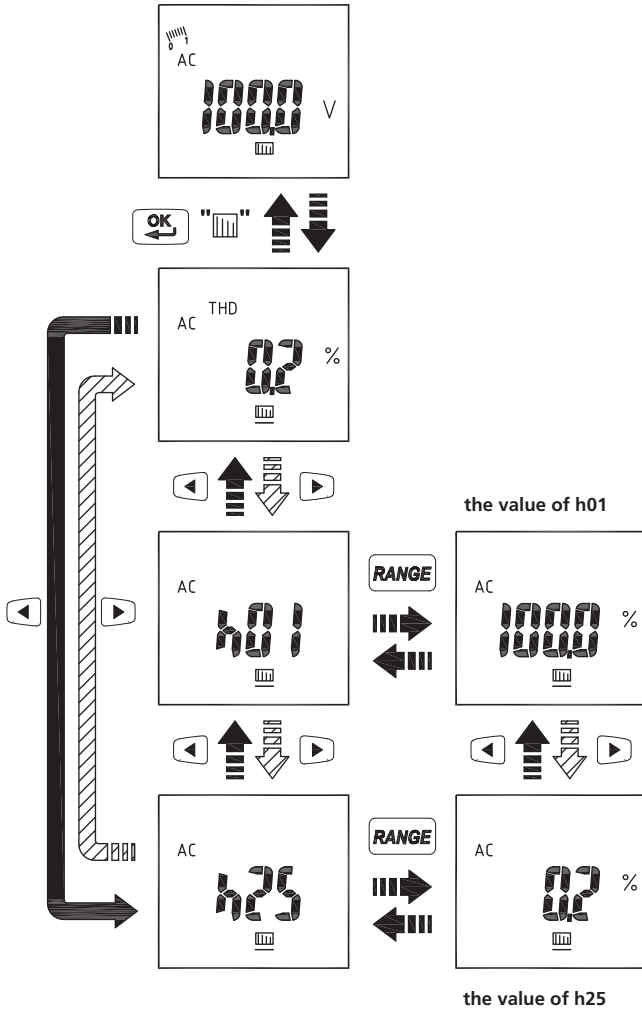

## HFR (High Frequency Rejection - AC mode only)

Select the "HFR" indicator then press the OK button to eliminate high frequency noise.

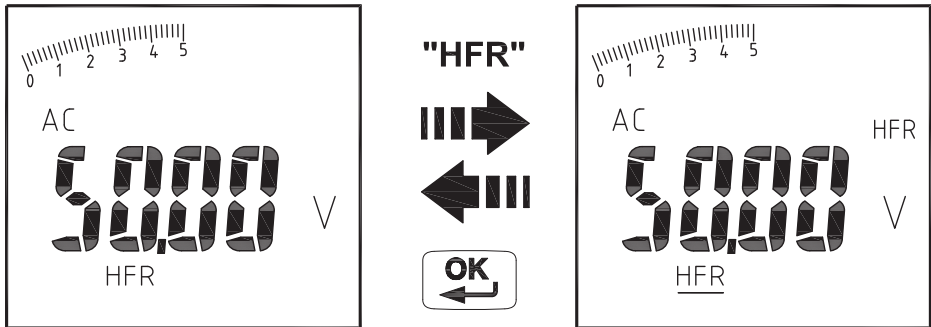

### NOTE:

Peak Hold, Inrush Current, HZ, Harmonic and HFR are only available in AC mode.

## Measuring Active power (W)/Power factor (PF)

### 1. Single Phase Power Measurement

Step 1. Set the rotary switch to the "W" position.

Step 2. Connect the Black test lead to the N and the Red test lead to the L.

Step 3. Press the trigger to open the transformer jaws and clamp one conductor only, making sure that the jaw is firmly closed.

Step 4. Use the MODE button to select the "ACW/DCW/PF" mode.

**NOTE:** - In AutoSense mode the meter will display DCW until an AC frequency has been detected.

### Active power sign:

(The current direction must be the same as the figure below)

No sign: Indicates the power flows from the power source to the load. "-" sign: Indicates the power flows from the load to the power source.

## Measuring active power (W)/Power factor (PF) cont

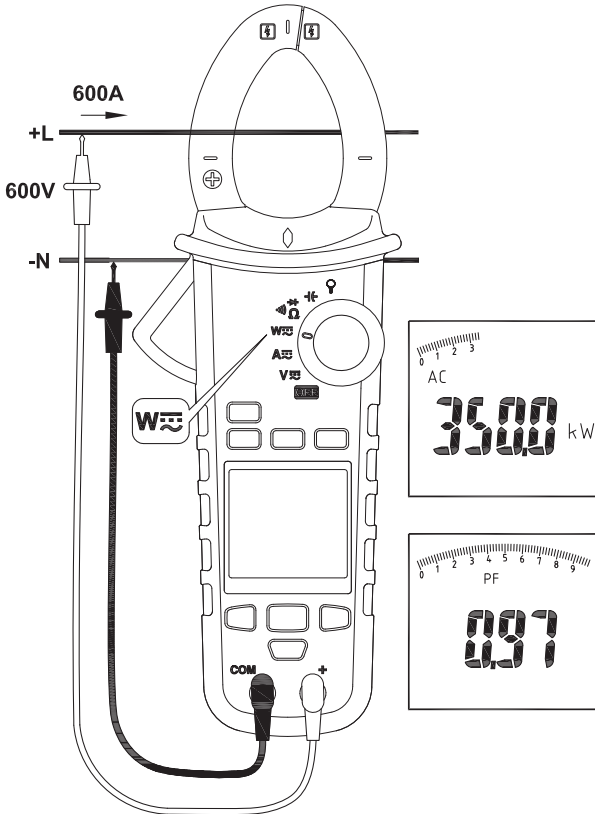

### Power factor sign:

No sign: The phase of the current signal is lagging behind the voltage signal (inductive load). “\_” sign: The phase of the current signal is leading the voltage signal (capacitive load).

### Overrange display:

OL.U: Voltage overload

OL.A: Current overload

± OL kW: Active Power > 1050 kW or < -1050 kW.

## Three phase power measurement 3 phase 3 wire balanced / unbalanced

Step 1. Set the rotary switch to the "W" position

Step 2. Using the MODE button, choose ACW.

$$W=W1+W2$$

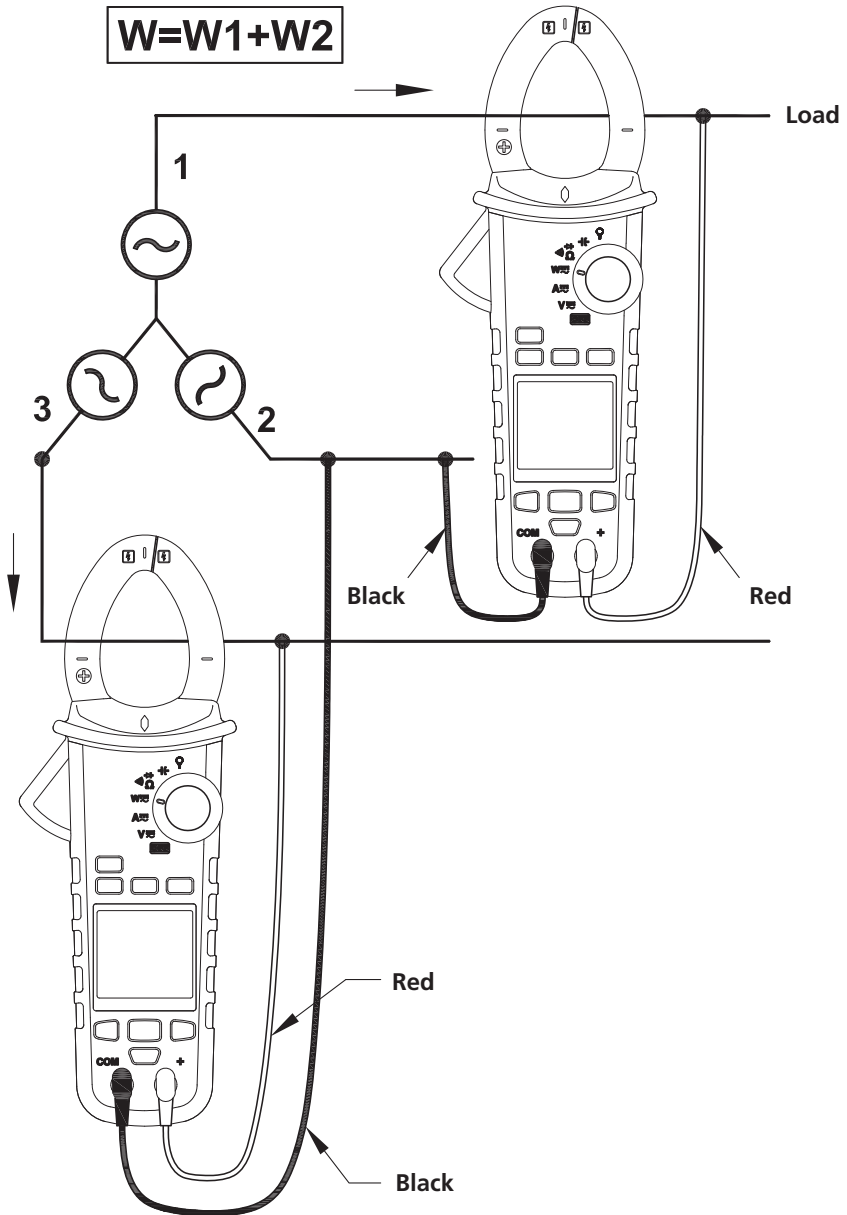

### 3 phase 4 wire balanced / unbalanced

Step 1. Set the rotary switch to the "W" position

Step 2. Using the MODE button, choose ACW.

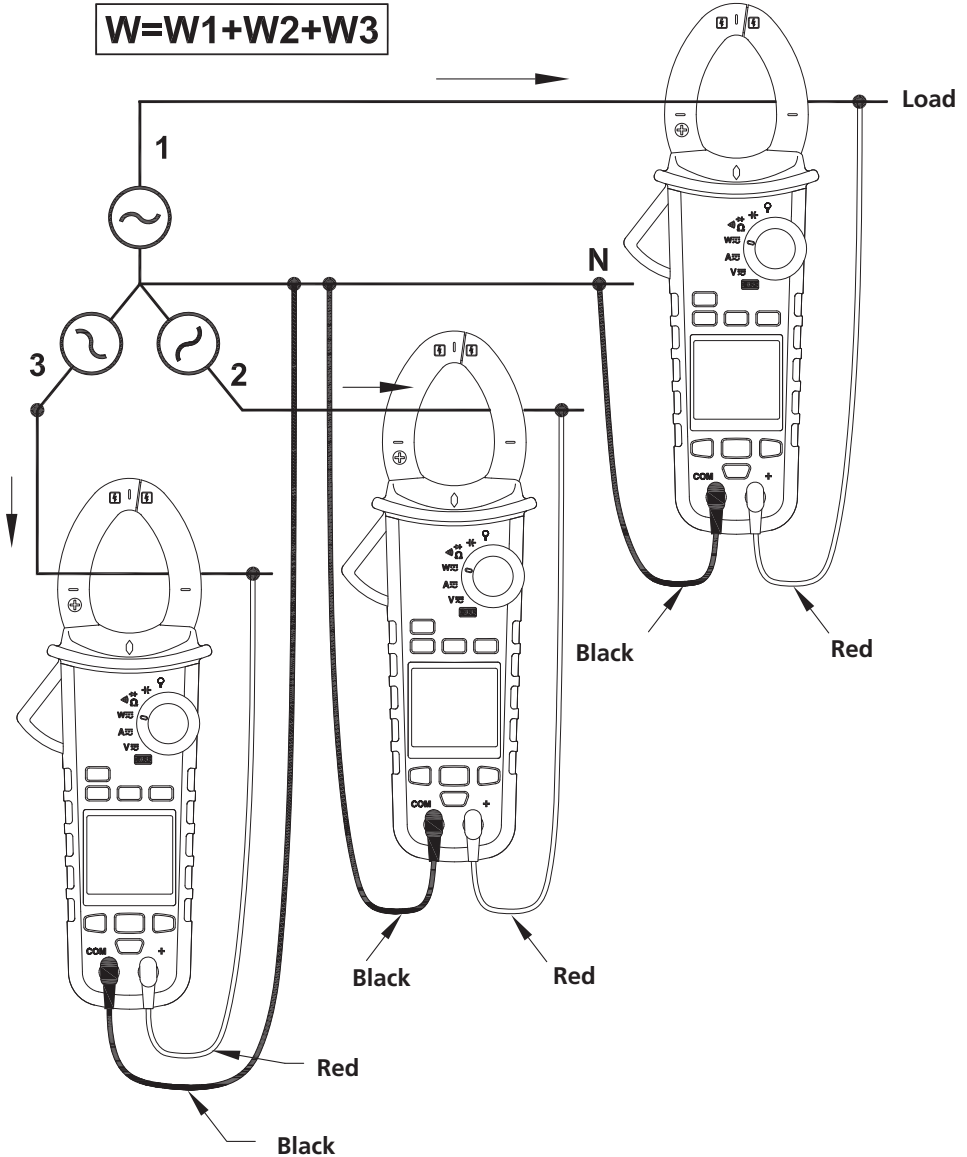

# Phase rotation

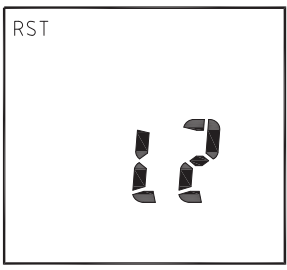
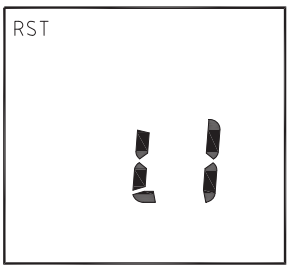
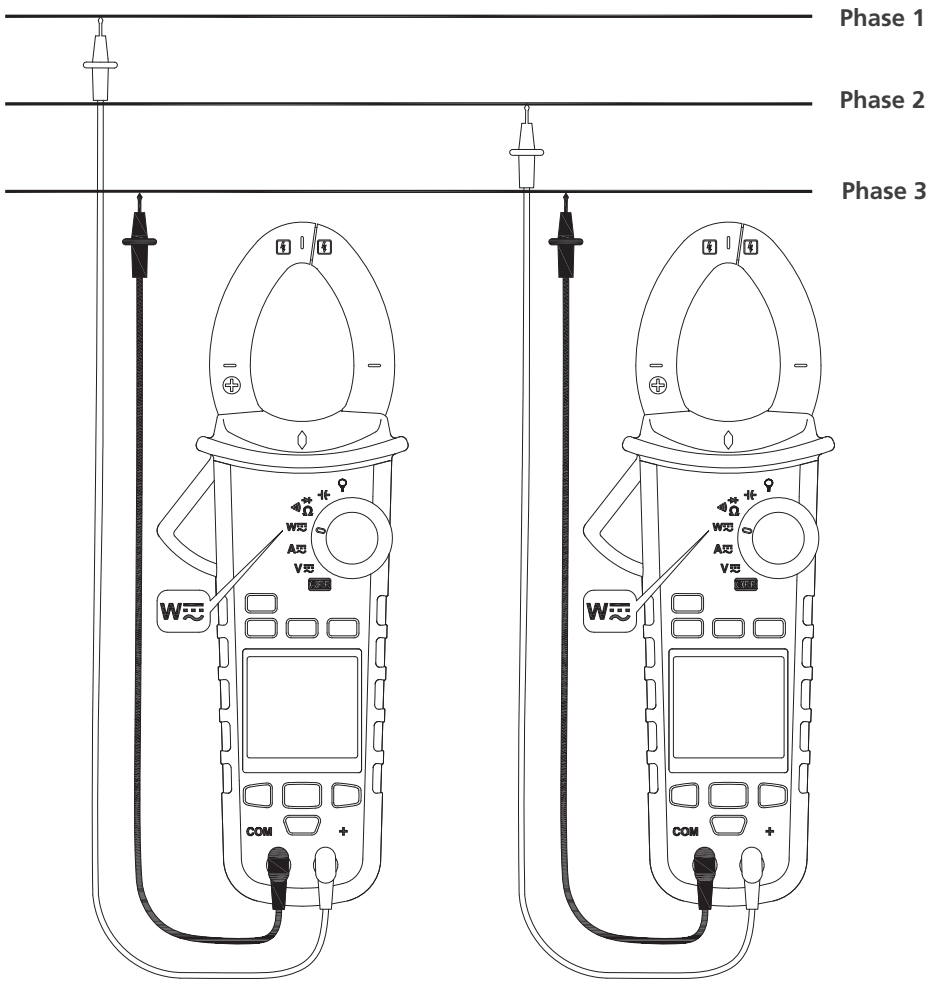

## Phase rotation cont

**NOTE:-** Connect the supposed three phase power source as shown above.

- The test is only available while the system frequency is stable.

Step 1. Set the rotary switch to the "W" position.

Step 2. Using the MODE button, choose the "RST" mode

Step 3. Connect the Red test lead to the supposed phase Line 1, and the Black test lead to the supposed phase Line 3.

- If volt > 1050 V, it will display "OLU" and flash; if volt < 30 V, it will display "LoU"
- If the frequency > 65 Hz or < 45 Hz, it will display "outF" and flash.
- If it is normal, then it will display "L1" for about 3 seconds.

Step 4. If it displays "L2", then BUZZER will sound twice.

Please switch the Red test lead to connect to the supposed phase Line 2 immediately before the "L2" disappears.

Step 5. When "L2" disappears, it will display the testing result.

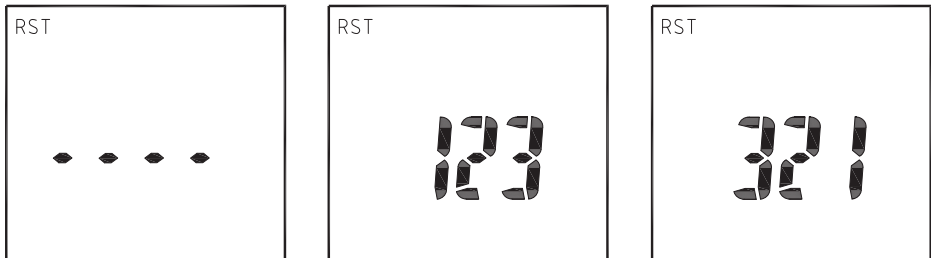

- If it displays "1 2 3", then the phase sequence is forward which means the supposed phase Line 1 is ahead of the supposed phase Line 2.
- If it displays "3 2 1", then the phase sequence is reversed which means the supposed phase Line 2 is ahead of the supposed phase Line 1.
- "----" means that the meter is unable to determine the results.
- If the meter displays "LoU", it is possible that the test leads were removed before completing the full testing procedure. Step 6: To repeat the test, press the OK button again.



## Ohm measurement

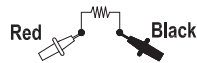
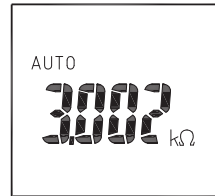
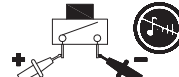
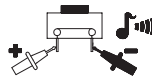
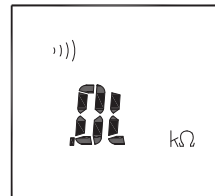
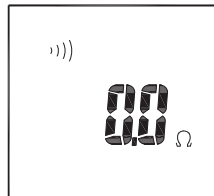
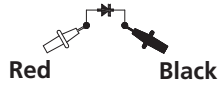
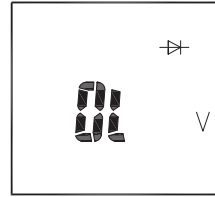
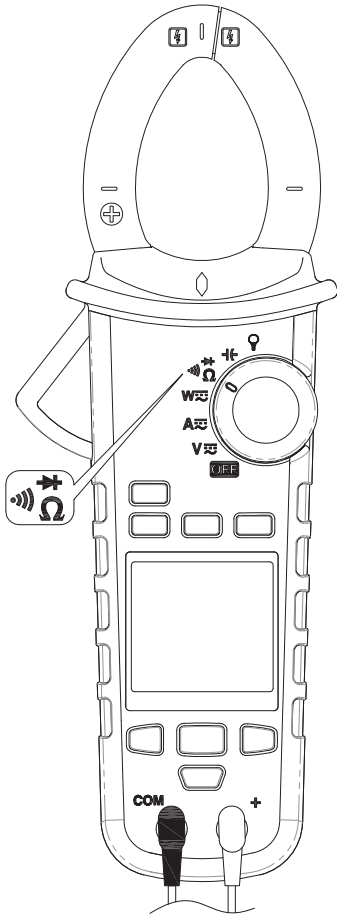

### CAUTION

To avoid possible damage to the Meter or to the equipment under test, disconnect circuit power and discharge all high voltage capacitors before measuring resistance and diode.

**Note:-** Press MODE button to enter the "Ω", ")))" or "➔+" mode.

- - The red LED will turn on, if the resistance of the DUT is < 30 Ω.

## Measuring capacitance

Set the rotary switch to the “ $\text{C}$ ” position.

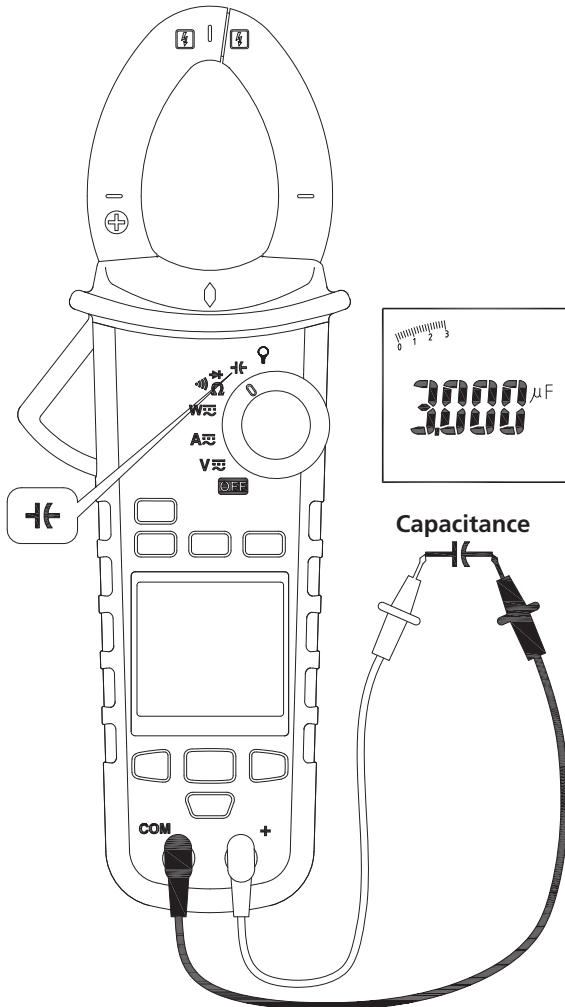

### CAUTION

To avoid possible damage to the meter or to the equipment under test, disconnect circuit power and discharge all high-voltage capacitors before measuring capacitance. Use the DC voltage function to confirm that the capacitor discharged.

**Note** - The meter will display “diSC” while discharging the capacitor.

## Measuring temperature °C / °F

Set the rotary switch to the "  " position.

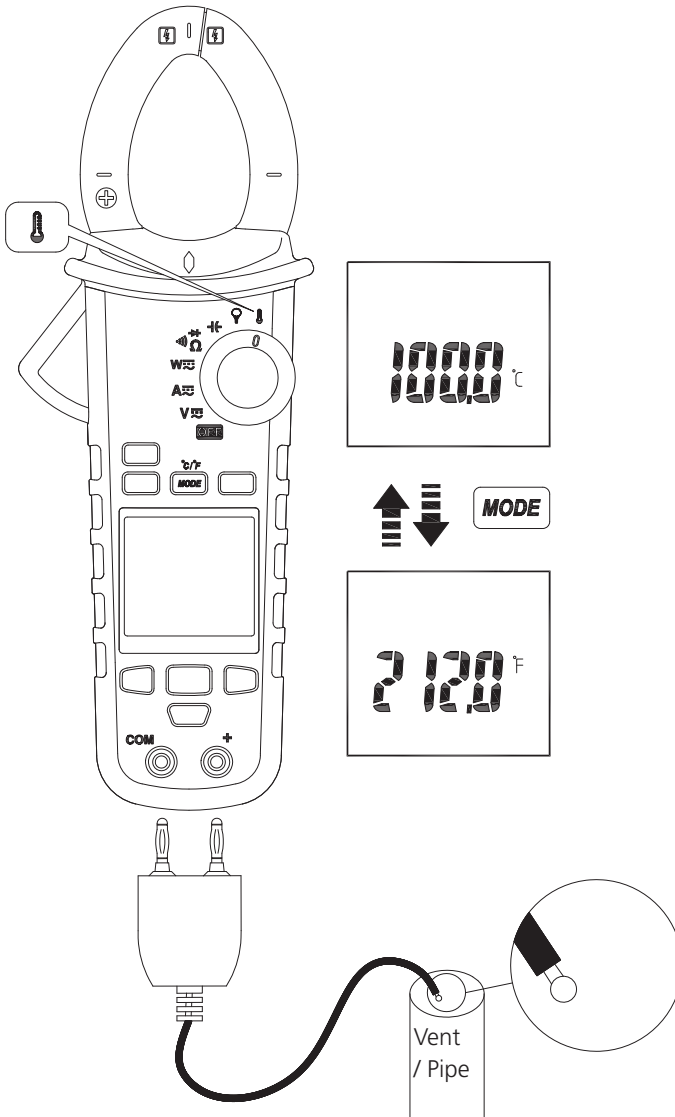

K Type Temperature probe

Do not take any high voltage measurement prior to making a temperature measurement as °C/°F measurement accuracy may be affected.

## Other functions:

### AUTO/MANUAL RANGE

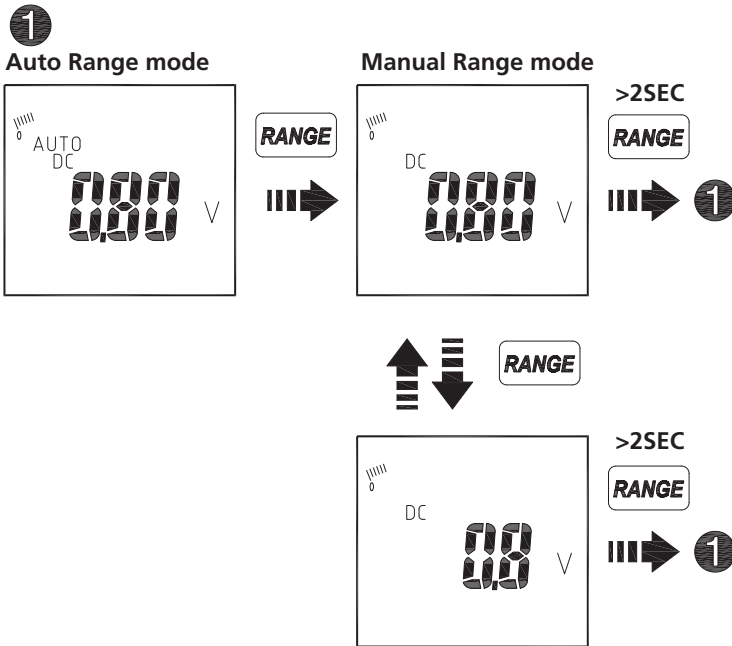

### HOLD Key

Press the HOLD key to freeze the displayed value.

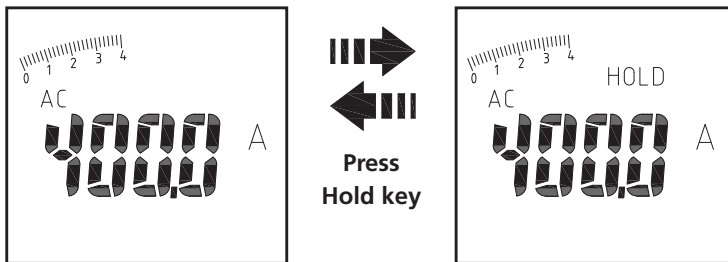

**SMART HOLD:** The meter will beep continuously and the display will flash if the measured signal is larger than the displayed reading (for V, A, W)

**MEM mode** When measuring you can save the reading to the memory or load it from the memory. The meter can store a maximum of 1000 data entries. To enter MEM mode use the Arrow keys to select the MEM icon and press the OK button. In this mode you can operate the following options:

<b>Use Arrow keys to select the following icons.</b>	
<b>A-SAVE</b>	<p>In A-SAVE mode, the meter will automatically capture and save each new reading made.</p> <p>In some cases, the A-SAVE mode will not work. For example, the reading is smaller than the A-SAVE limit, or the reading is OL.</p> <p>Press OK button to enter/exit A-Save mode.</p> <p>Press RANGE button to display the recorded data amount / currently measured value.</p>
<b>SAVE</b>	<p>Press OK button to enter SAVE mode. Press OK button to save a new reading to memory.</p> <p>Press RANGE button to display the number of records saved/ current measured value.</p> <p>Press OK button for more than 2 seconds to exit the mode.</p>
<b>LOAD</b>	<p>Press OK button to enter/exit LOAD mode. Press LEFT or RIGHT button to select data.</p> <p>Press RANGE button to select data index/recorded value.</p>
<b>CLR</b>	<p>Press OK button to enter CLR mode.</p> <p>Press OK button to delete all data in memory. Press OK button for more than 2 seconds to exit this mode.</p>
<b>MMA (MAX/MIN)</b>	<p>MMA mode is only valid when A-Save mode has executed and finished. Press OK button to enter MMA mode.</p> <p>Press OK button to display the maximum/minimum value</p> <p>Press OK button for more than 2 seconds to exit this mode.</p>

To exit MEM mode, use Arrow keys to select the MEM icon and press the OK button.

#### **A-Save limit.**

<b>Function</b>	<b>Limit</b>
<b>V, A, W, Cap</b>	5 % of range
<b>Hz</b>	10% of 100 Hz range 5% of 1k/10kHz range

## LOG mode

---

You can record a number of readings to memory over a period of time and download the data to produce graphs and reports. The meter can store a maximum of 9999 records in memory.

The recording interval can be set from 1 second to 600 seconds. The accuracy of the timer is within 3 seconds per hour. To enter LOG mode use the Arrow keys to select the LOG icon and press the OK button to enter.

In this mode you can access the following options:

<b>Use the Arrow keys to select the following icons.</b>	
SAVE	Press OK button to start data logger. The logger automatically records at the set intervals. To stop data logger, press OK button to return.
LOAD	Press OK button to review the data from memory. Press LEFT or RIGHT button to select data. Press RANGE button to select data index/recorded value. Press OK button to return.
RATE	Press OK button to setup the sample interval. Press LEFT or RIGHT button to select rate. Press OK button to return.
LOG	To exit the LOG mode, select the LOG icon, and press the OK button

## Bluetooth

---

The meter uses low-power Bluetooth v4.0 wireless technology to transfer real-time data to the free Megger Link™ app - available for both iOS and Android.

The maximum communication range in open air is approximately 10 m.

This feature is unavailable when measuring Inrush Current or Phase Rotation.

Download the “Megger Link™” App. Turn on the Bluetooth function of the meter by pressing the Bluetooth button and open the Megger Link™ App to connect the DCM.



**QR Code for the  
Megger Link App  
on the Google  
Play Store**



**QR Code for the  
Megger Link App on  
the Apple App Store**



The Bluetooth icon of the meter will flash whilst connecting and freeze on the LCD after the connection is established.

## VoltSeek:

---

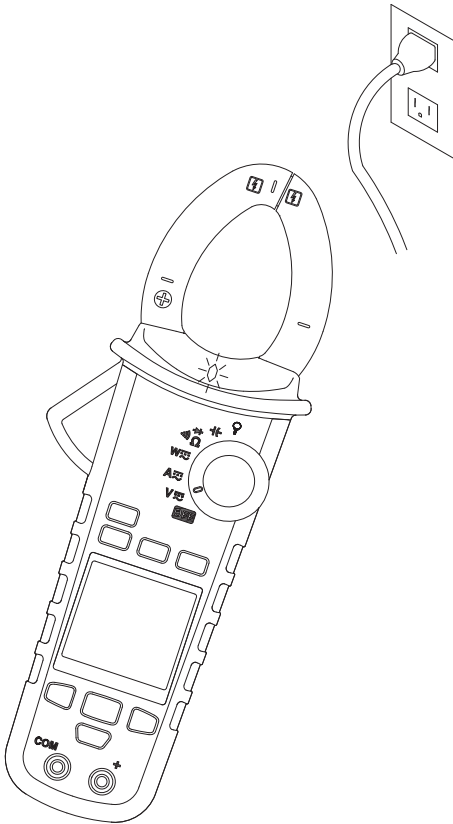

The red diamond shape LED will illuminate if an electric field has been detected by the jaw.

**Note** - This function is invalid for OHM, Capacitance, Inrush and Phase Rotation.

### **Caution**

The light indicator turns on while the clamp tips are close to an electric field. If there is no indication, voltage could still be present.

## Buzzer

---

The meter beeps once for every valid key-press, and beeps twice for any invalid key press. The meter will beep twice on 3 occasions, prior to APO (Auto Power Off)

### Power-up options:

---

Press one of the following buttons while tuning meter on from OFF position.

**UP/DOWN button:** Display of the software version.





**OK button:** Disable auto power off. The display shows "AoFF".

**LEFT button:** Disable active backlight. The display shows "LoFF".

**HOLD BUTTON:** Display all LCD symbols approx 10 seconds.

## Battery state display

User can know the battery state from the battery indicator.

Battery state	Description
	The battery is fully charged
	The battery has 66% power remaining
	The battery has 33% power remaining
	Replace the battery as soon as the low battery indicator appears to avoid inaccurate readings

## Battery replacement

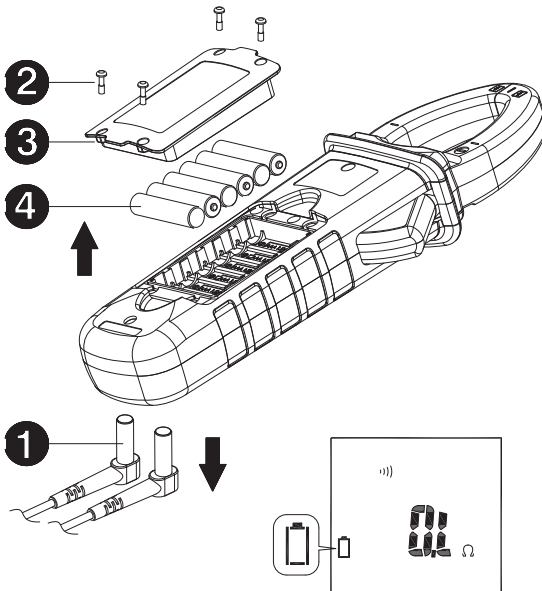



## Specifications

---

### General Specifications

Overload protection:	1000 Vrms / 1000 Arms
Display count:	10000
Measuring rate:	3 times / sec.
Overrange display:	"OL" or "-OL".
Auto Power Off:	Approximately 15 minutes.
Power requirement:	6 x 1.5 V AAA alkaline batteries.
Battery life:	~60 hours (without Backlight).
Dimensions:	103 mm(W) x 258 mm(L) x 55 mm(D)
Weight:	approx. 600 g (with battery) approx. 532 g (without battery)

### Environmental Conditions

**IP Rating** IP40

**Calibration:** One-year calibration cycle.

**Operating temperature:**

0 °C ~ 10 °C

10 °C ~ 30 °C (≅80% RH)

30 °C ~ 40 °C (≅75% RH)

40 °C ~ 50 °C (≅45% RH)

**Storage temperature:** -10 to 50 °C

0 to 80% RH (batteries not fitted).

**Temperature coefficient:**

0.2 x (Specified accuracy) / °C, < 18 °C, > 28 °C.

Over voltage category: IEC 61010-1 600 V CAT IV/1000 V

CAT III IEC 61010-2-32, IEC 61010-2-33

**Operating altitude:**

2000 m (6562 ft) Conductor Size: 40 mm diameter Pollution degree: 2

EMC: EN 61326-1

**Shock Vibration:** Per MIL-PRF-28800F for a Class 2 instrument.

Drop Protection: 1.2 m drop to hardwood on a concrete floor.

### Electrical Specifications

Accuracy is  $\pm$ (% reading + number of digits) at 23 °C  $\pm$  5 °C

< 80% RH.

#### (1) Voltage

Function	Range	Accuracy*
DCV	99.99 V	$\pm$ (0.7% + 2dgt)
	999.9 V	
ACV	99.99 V	$\pm$ (1.0% + 5dgt)
	999.9 V	50 ~ 500Hz
HFR ACV	99.99 V	50 ~ 60Hz $\pm$ (1% + 5dgt)
	999.9 V	>60 ~ 400Hz $\pm$ (5% + 5dgt)

\* DCV <1000dgt, add 6 digits to the accuracy.

ACV <1000dgt, add 3 digits to the accuracy.

**Input Impedance:** 3.5M $\Omega$  // <100pF

**AC Conversion Type:** AC Conversions are ac-coupled, true RMS responding, calibrated to the RMS value of a sine wave input. Accuracies are given for sine wave at full scale and non-sine wave below half scale. For non-sine wave (50/60 Hz) add the following Crest Factor corrections:

For Crest Factor of 1.4 to 2.0, add 1.0% to accuracy.

For Crest Factor of 2.0 to 2.5, add 2.5% to accuracy.

For Crest Factor of 2.5 to 3.0, add 4.0% to accuracy.

CF 3 @ 460 V, 460 A

2 @ 690 V, 690 A

**AC+DC Vrms Accuracy:** same as ACV spec. +DCV spec.

## (2) Current

Function	Range	Accuracy
DCA	99.99 A	$\pm (1.5\% + 0.2 \text{ A})$
	999.9 A	$\pm (1.5\% + 5\text{dgt})^{**}$
ACA	0.10 A ~ 99.99 A	50 ~ 60 Hz $\pm (1.5\% + 5\text{dgt})^{**}$
	999.9 A	>60 ~ 400 Hz $\pm (2\% + 5\text{dgt})^{**}$
HFR ACA	0.10A ~ 99.99 A	50 ~ 60 Hz $\pm (1.5\% + 5\text{dgt})^{**}$
	999.9 A	>60 ~ 400 Hz $\pm (5\% + 5\text{dgt})^{**}$

\*\* The measured value <1000dgt, add 5 digits to the accuracy.

**Position Error** :  $\pm 1\%$  of reading.

AC Conversion Type and additional accuracy is same as AC Voltage.

**AC+DC Arms Accuracy**: Same as ACA spec + DCA spec.

- DCA can be affected by the temperature and the residual magnetism.

Press HOLD key > 2 seconds to compensate it.

### Flexible Current Probe

Range	OL	Reading Resolution	Accuracy
300.0A	330.0A	0.1A	$\pm(1.5\% + 5D)$
3000A	3300A	1A	$\pm(1.5\% + 5D)$

**Frequency Response** : 45Hz to 400Hz

Accuracy does not include accuracy of the Flexible Current Probe.

**Overload Protection** : AC/DC 1000V

## (3) Peak Hold: Peak MAX / Peak MIN

**Accuracy defined for:**

Function	Range	Accuracy
ACV	140.0 V	$\pm (3.0\% + 15\text{dgt})$
	1400 V	

ACA	140.0 A	± (3.0% + 15dgt)
	1400 A	

Sine wave, ACV>5 Vrms / ACA>5 Arms, Frequency 50~400 Hz.

- For square wave, the accuracy is unspecified.
- Only suitable for the repetitive events.

#### (4) Frequency

Function	Range	Accuracy
Frequency	20.00 ~ 99.99 Hz	± (0.5% + 3dgt)
	20.0 ~ 999.9 Hz	
	0.020 ~ 9.999 KHz	

#### Sensitivity:

- 10~100 Vrms for AC 100 V range
- 10~100 Arms for AC 100 A range ( >400 Hz Unspecified)
- 100~1000 Vrms for AC 1000 V range
- 100~1000 Arms for AC 1000 A range ( >400 Hz Unspecified)
- Reading will be 0.0 for signals below 10.0 Hz.

#### (5) Total Harmonic Distortion :

Function	Range	Accuracy
ACA /ACV	99.9%	± (3.0% + 10dgt)

#### Harmonic distortion measurement:

Harmonic order	Range	Accuracy
H01 ~ H12	99.9%	± (5% + 10dgt)
H13 ~ H25		± (10% + 10dgt)

- If ACV<10 Vrms or ACA <10 Arms, it will display "rdy".
- If the fundamental frequency out of range 45 ~ 65 Hz, it will display "out.F".

## (6) Inrush Current :

### Accuracy defined for:

Function	Range	Accuracy
ACA	99.99 A	$\pm (2.5\% + 0.2 \text{ A})$
	999.9 A	$\pm (2.5\% + 5\text{dgt})$

Sine wave, Freq. 50/60 Hz

- Operational response approx. 100 ms

**Trigger level of INRUSH:** 1 Arms for 100 A range  
10 A rms for 1000 A range

## (7) Active Power: Watt (DC/AC)

Function	Range	Accuracy
ACW / DCW	9.999 kW**	$A_{\text{error}} \times V_{\text{reading}} + V_{\text{error}} \times A_{\text{reading}}$
	99.99 kW	
	999.9 kW	

\*\* The measured value < 1.000 kW add 10 digits to the accuracy.

### Accuracy defined for:

ACW:

Sine wave, ACV  $\geq 10$  Vrms, ACA  $\geq 5$  Arms

Freq. 50~60 Hz, PF=1.00

DCW:

DCV  $\geq 10$  V, DCA  $\geq 5$  A

## (8) Power Factor

Function	Range	Accuracy
PF	1.00	$\pm 5\text{dgt}$

### (9) Resistance & Continuity & Diode :

Function	Range	Accuracy
Resistance	999.9 $\Omega$	$\pm (1.0\% + 5\text{dgt})$
	9.999 k $\Omega$	
	99.99 k $\Omega$	
Continuity	999.9 $\Omega$	$\pm (1.0\% + 5\text{dgt})$
Diode	0.40~ 0.80 V	$\pm 0.1\text{V}$

To obtain a more accurate resistance reading, the lead resistance should be measured by connecting the probes/clips together and the result deducted from any resistance measurement taken.

**Max. Test Current:** Approx. 0.5 mA.

**Maximum Open Circuit Voltage for  $\Omega$ , ** : Approximate 3 V

**Maximum Open Circuit Voltage for diode:** Approximate  $\pm 1.8$  V

**Continuity Threshold :**

<30  $\Omega$  Beep On.

>100  $\Omega$  Beep OFF.

**Continuity Indicator:** 2 kHz Tone Buzzer

**Continuity response time:** < 100 ms.

### (10) Capacitance:

Function	Range	Accuracy
Capacitance	3.999 $\mu\text{F}$	$\pm (1.9\% + 8\text{dgt})$
	39.99 $\mu\text{F}$	
	399.9 $\mu\text{F}$	
	3999 $\mu\text{F}$	

### (11) Temperature

Function	Range	Accuracy
$^{\circ}\text{C}$	-50 $^{\circ}\text{C}$ ~ 399.9 $^{\circ}\text{C}$	$\pm (1\% + 3^{\circ}\text{C})$
	400 $^{\circ}\text{C}$ ~ 1000 $^{\circ}\text{C}$	
$^{\circ}\text{F}$	-58 $^{\circ}\text{F}$ ~ 751.9 $^{\circ}\text{F}$	$\pm (1\% + 6^{\circ}\text{F})$
	752 $^{\circ}\text{F}$ ~ 1832 $^{\circ}\text{F}$	

- The above specification is assumed at the ambient temperature stability within  $\pm 1^{\circ}\text{C}$ . In addition, the temperature probe has to be connected to meter for more than 1 hour in advance.

The meter needs 2 hour for stability for any ambient temperature change of more than  $\pm 5$  °C.

## **(12) VoltSeek**

Voltage Range of Sensitivity

>100 ~ 1000 V AC (At the top edge of the jaw)

Product manufactured in Taiwan

## **Maintenance**

---

Do not attempt to repair this clamp meter. It contains no user-serviceable parts. Repair or servicing should only be performed by qualified personnel.

## **Cleaning**

---

Periodically wipe the case with a dry cloth and detergent, do not use abrasives or solvents.

## **WEEE Directive**

---

The crossed out wheeled bin symbol placed on Megger products is a reminder not to dispose of the product at the end of its life with general waste.

Megger is registered in the UK as a Producer of Electrical and Electronic Equipment. The Registration No is WEE/ HE0146QT.

For further information about disposal of the product consult your local Megger company or distributor or visit your local Megger website.

## **Battery disposal**

---

The crossed out wheeled bin symbol placed on a battery is a reminder not to dispose of batteries with general waste when they reach the end of their usable life.

For disposal of batteries in other parts of the EU contact your local Megger branch or distributor.

Megger is registered in the UK as a producer of batteries (registration No.: BPRN00142).

For further information see [www.megger.com](http://www.megger.com)



## **Warranty (3 years)**

---

This meter is warranted to the original purchaser against defects in material and workmanship for 3 year from the date of purchase.

During this warranty period, the manufacturer will, at its option, replace or repair the defective unit, subject to verification of the defect or malfunction.

This warranty does not cover fuses, disposable batteries, or damage from abuse, neglect, accident, unauthorised repair, alteration, contamination, or abnormal conditions of operation or handling.

Any implied warranties arising out of the sale of this product, including but not limited to implied warranties of merchantability and fitness for a particular purpose, are limited to the above. The manufacturer shall not be liable for loss of use of the instrument or other incidental or consequential damages, expenses, or economic loss, or for any claim or claims for such damage, expense or economic loss. Some states or countries laws vary, so the above limitations or exclusions may not apply to you.

Megger Limited Archcliffe Road Dover

Kent CT17 9EN

Tel: +44 (0) 1304 502 101 Fax: +44 (0) 1304 207 342 [www.megger.com](http://www.megger.com)

## Local Sales office

---

Megger Limited  
Archcliffe Road  
Dover  
Kent  
CT17 9EN  
ENGLAND  
T. +44 (0)1 304 502101  
F. +44 (0)1 304 207342

## Manufacturing sites

---

Megger Limited  
Dover, ENGLAND  
T. +44 (0)1 304 502101  
E. [uksales@megger.com](mailto:uksales@megger.com)

Megger AB  
Danderyd, SWEDEN  
T. +46 08 510 195 00  
E. [seinfo@megger.com](mailto:seinfo@megger.com)

Megger Valley Forge  
Phoenixville, PA USA  
T. +1 610 676 8500  
E. [USsales@megger.com](mailto:USsales@megger.com)

Megger USA - Dallas  
Dallas, TX USA  
T. +1 214 333 3201  
E. [USsales@megger.com](mailto:USsales@megger.com)

Megger USA - Fort Collins  
Fort Collins, CO USA  
T. +1 970 282 1200

Megger GmbH  
Aachen, GERMANY  
T. +49 (0) 241 91380 500  
E. [info@megger.de](mailto:info@megger.de)

Megger Germany GmbH  
Baunach, GERMANY  
T. +49 (0) 9544 68 - 0  
E. [baunach@megger.com](mailto:baunach@megger.com)

Megger Germany GmbH  
Radeburg, GERMANY  
T. +49 (0) 35208 84-0  
E. [radeburg@megger.com](mailto:radeburg@megger.com)

**This instrument is manufactured in China.**

**The company reserves the right to change the specification or design without prior notice.**

**Megger is a registered trademark**

**The Bluetooth<sup>®</sup> word mark and logos are registered trademarks owned by Bluetooth SIG, Inc and is used under licence.**