

## APPLICATION NOTE

# BVM system/connections

This document give additional information about the battery voltage monitoring system BVM and how those units are connected.

### 1. Connection examples

**Loop with Torkel 900. Battery string max 300V. Max 120 cells.**

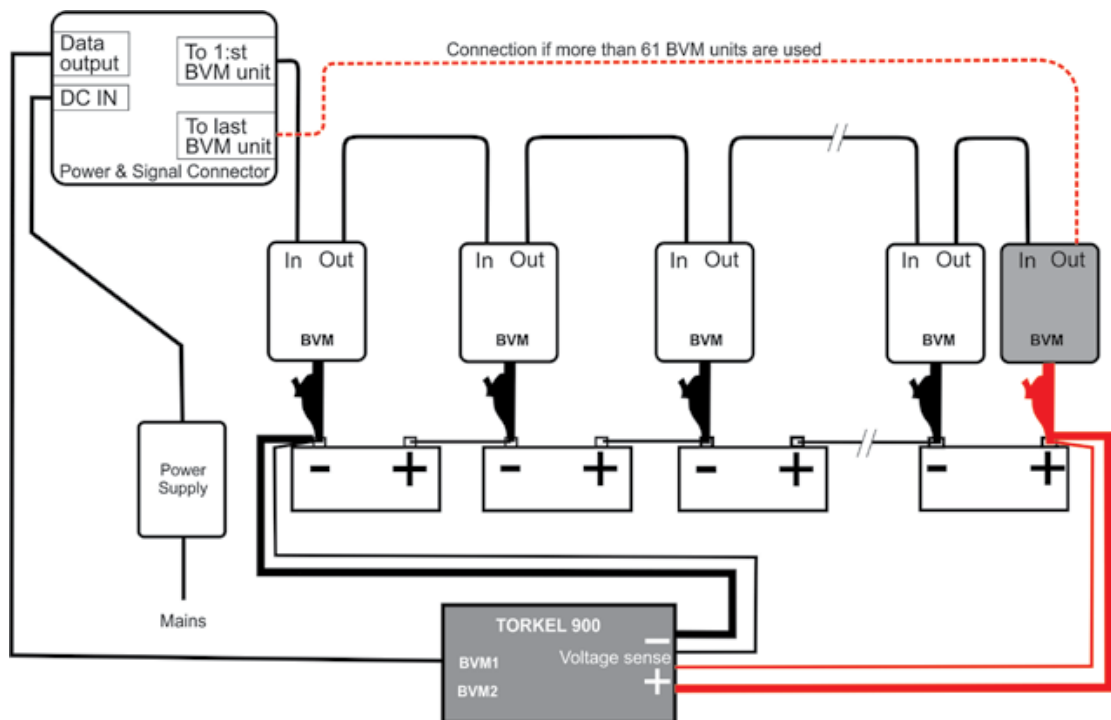

The BVM units must be connected following the battery cell sequence order. The red dolphin clip shall be connected to the most positive battery pole of the battery. The voltage over each BVM unit will be logged throughout the complete discharge test.

## Connection diagram with BVM and Torkel 930/950. Max 300V on each loop.

Max 2 x 120 cells.

Battery string max 300V for Torkel 930

Battery string max 500V for Torkel 950

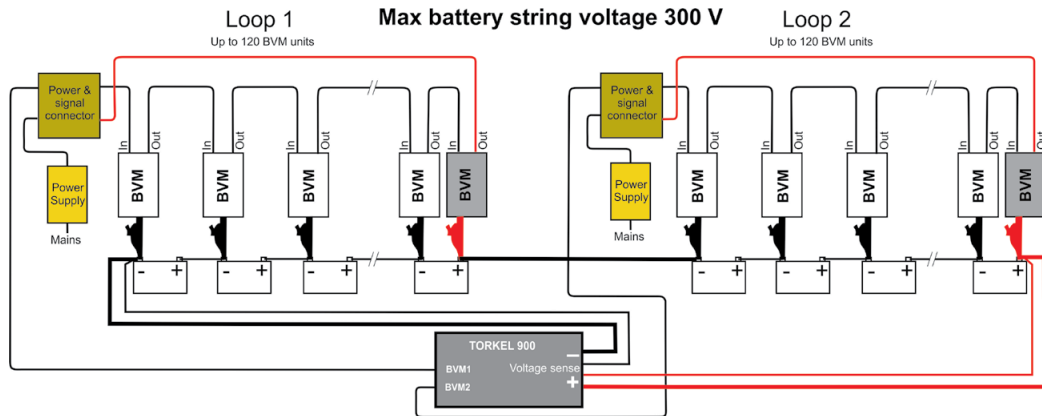

When the battery bank exceeds 120 cells, connection with 2 BVM loops shall be used.

Connect the first loop to the BVM1 USB port on TORKEL 900 and the second loop to the BVM2 USB port on TORKEL 900

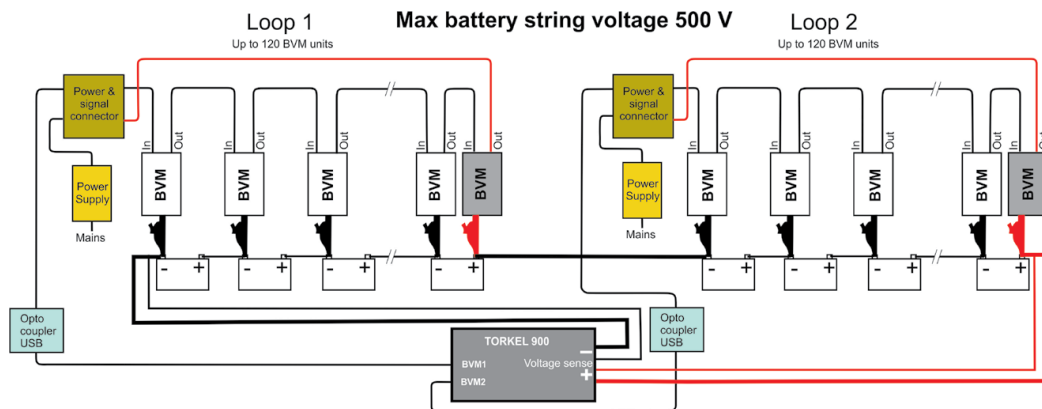

The connection shown above must be used when the battery bank voltage is between 300 V and 500 V. It includes two opto couplers and two ungrounded power supplies.

## Connection diagram with BVM and use of PC and PowerDB or Torkel Win

For monitoring of the battery string. BVM Special 600V, 2 x 22pcs. 12V blocks (Art no CJ-59198)

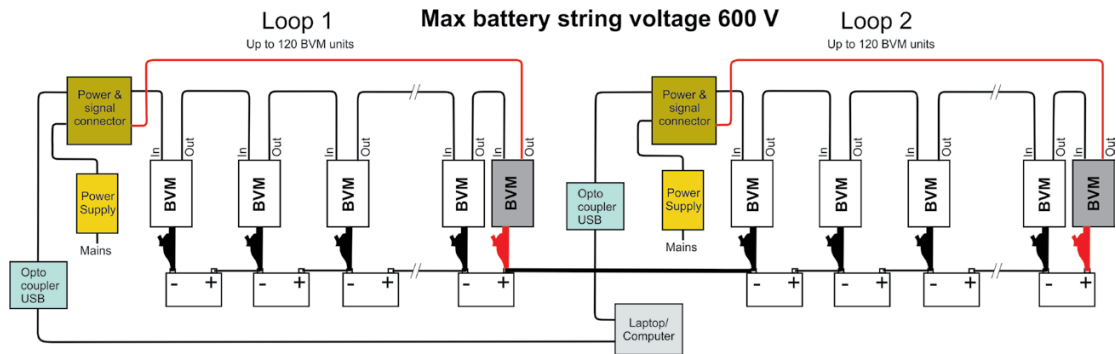

When the battery bank voltage exceeds 500V, Torkel cannot be used. Instead the voltage measured from the cell/block can be monitored from a PC using PowerDB or Torkel Win report sw. This require use of 2 pcs. opto couplers ( Art no HC-50040 ) and 2 pcs. ungrounded power supplies ( Art no HC-04155 ) for each loop. Each loop not to exceed 300V.

## 2. Accessories for connection of BVM to battery poles

### Clips to connect to battery poles

Dolphin clip are included all kits. The amount correspond to the amount of BVM units and the amount of cells that can be measured. The first clip, intended for the last positive pole is included. The other are black.



When ordered separately these are the article numbers:

Art no: 40-08320 (black)

Art no: 40-08322 (red)

### Extension lead

The extension lead can be used to add an extension from the BVM unit to the dolphin clip.

Art no: **04-30050**



### Additional monitoring unit

One additional BVM unit to add possibility to monitor one more cell.

Art no: **CJ-59090**

The unit is delivered with one black dolphin clip (40-08320) and one Ethernet cable 0,5m (GA-01100)



### Cable with ring connector for battery poles

Cable with M8 ring connector, 0.3 m for permanent installation on the battery.

Art no: **KG-00690**



### Cable with quick connector for battery poles

Cable with 6.3 mm insulated female flat connector, 0.3 m. Used together with a M8 cable lug (45-10046) that is installed at the battery pole



Art no: **KG-00692**

Cable lug to install on the battery pole. These are left there and at the test the cable can easily be connected.



Art no: **45-10046**



### Battery pole for battery poles

This battery pole bolt with dimension M8 replaces the ordinary battery plug and gives on the top a quick connection point for a standard banana plug.

Art no: **04-06300**



### Extension lead

The extension lead is used to have additional freedom in placing the BVM units. See the example picture where it is used to release stress from the clip by placing the BVM unit further away. It could for example also be placed on the top of the battery.

Art no. **04-30050**

Velcro band, length 0.3 m

Art no. **19-62200**

