

LOCTITE®

The Equipment Sourcebook

2014 – VOLUME 10



Excellence is our Passion

The Equipment Sourcebook

Since 1971, Henkel Corporation has designed, built and integrated high-quality equipment solutions. From simple handheld devices to fully automated systems, Henkel offers a complete line of standard off-the-shelf LOCTITE® brand dispensing and light curing equipment, which can be integrated easily into your manufacturing process.

Introduction

From water-thin liquids to high-viscosity pastes, LOCTITE® brand equipment is capable of dispensing and curing a wide variety of adhesives, sealants and other industrial fluids:

Adhesives and Sealants

Acrylics	Hot Melts
Anaerobics	Silicones
Cyanoacrylates	Urethanes
Epoxies	UV/Light Curing Adhesives

Industrial Fluids

Accelerators/Activators	Paints
Greases	Primers
Inks	Solvents
Lubricants/Oils	Solder Pastes

In addition to our standard line of equipment, Henkel offers a number of resources to support your dispensing needs:

- **Custom Equipment Systems** – We can modify any LOCTITE® brand standard system or customize a system to meet your specific assembly needs.
- **Equipment Rental Program** – Evaluate the performance of our equipment before making a capital investment.
- **Equipment Website** – Locate details on LOCTITE® brand standard and custom equipment, parts and accessories, and equipment services. To learn more about our equipment, or to find the name and phone number of your nearest authorized distributor, visit www.equipment.loctite.com.
- **Adhesive and Sealant Specialists** – Henkel Adhesive and Sealant Specialists are available across the continent to personally assist you with new assembly challenges or to help you re-engineer an existing application for improved performance and cost savings using LOCTITE® brand products. Contact us at **1.800.LOCTITE** (562.8483) or visit www.loctite.com.

The Adhesive Sourcebook

In addition to our dispensing and curing equipment, Henkel offers a complete line of adhesives, sealants, cleaners, lubricants, potting compounds and coatings. More than 1,400 products in total!

To view our online catalog, visit www.loctite.com, or to request a copy, send an email to literature@loctite.com, and reference [the Adhesive Sourcebook, LT-3355](#).

Engineering Services

Henkel now offers complete engineering services for projects demanding expertise and support beyond the limits of our standard technical services. As a result, our engineers and scientists can quote the following value-added services:

- On-site engineering assistance and consultation
- Joint product development programs
- Contract lab services and testing
- Prototype testing and fixture preparation
- Custom formulations

For more information on these and other Henkel Engineering Services, contact your Henkel Adhesive and Sealant Specialist at **1.800.LOCTITE** (562.8483).

Contents

INTRODUCTION

EQUIPMENT SERVICE SOLUTIONS	3
-----------------------------	---

DISPENSING

DISPENSE SYSTEMS – ADHESIVE BOTTLES

LOCTITE® Benchtop Peristaltic Dispenser	6
LOCTITE® Bond-A-Matic® 3000 Dispenser	7
LOCTITE® Dual Channel Integrated Dispenser	7

DISPENSE SYSTEMS – PNEUMATIC

SYRINGE DISPENSING

LOCTITE® Posi-Link™ Volumetric Dispense System for Prepackaged Syringes	9
LOCTITE® Posi-Link™ Syringe Nests	10
LOCTITE® Precision Syringe Dispensing System	11
LOCTITE® EQ SD10 Digital Syringe Dispenser	11
LOCTITE® Digital Syringe Dispensing System	12
LOCTITE® Foot Pedal Dispenser	12
LOCTITE® 30 ml PUR™ Dispenser System	13

DISPENSE SYSTEMS – TUBE BONDING

LOCTITE® Light Cure Acrylic Adhesive Dispensing System	14
--------------------------------------------------------	----

DISPENSE SYSTEMS – CONTROLLERS

& RESERVOIRS

LOCTITE® Dual-Channel Automatic Controller	16
LOCTITE® Spray Valve Controller	17
LOCTITE® Digital Multi-Functional Controller	17
LOCTITE® Digital Dispense Controller	18
LOCTITE® Bond-A-Matic® 3000 Reservoir	19
LOCTITE® Shot Miser™ Reservoir	19

BENCHTOP, HANDHELD & SOFT PACK

CARTRIDGE DISPENSING

LOCTITE® High Pressure 300 ml Benchtop Dispenser	21
LOCTITE® 300 ml Cartridge Pusher	21
LOCTITE® EQ HD10 300 ml Pneumatic Cartridge Dispenser	22
LOCTITE® 300 ml Pneumatic Cartridge Dispenser Retainer	22
LOCTITE® Soft Press Hand Held Pneumatic Applicator	22

VOLUMETRIC DISPENSING

LOCTITE® Posi-Link™ Controller	23
LOCTITE® Posi-Link™ Actuator	23
LOCTITE® Posi-Link™ 50 ml Dual Cartridge Nest	24
LOCTITE® Pinch Tube Valve	24

SINGLE COMPONENT VOLUMETRIC DISPENSING

LOCTITE® Compact Rotor Pump Dispense System	25
---------------------------------------------	----

TWO-COMPONENT VOLUMETRIC DISPENSING – METER MIX SYSTEMS

LOCTITE® DuraPump™ Programmable Meter Mix Systems	27
---------------------------------------------------	----

LOCTITE® DuraPump™ Pneumatic Meter Mix Systems	28
LOCTITE® Brand Meter Mix System Options & Accessories	29
LOCTITE® 50 ml Dual Cartridge Dispensers	30

HANDHELD APPLICATORS

LOCTITE® 50 ml/250 ml Hand Pumps	32
LOCTITE® CA Volumetric Hand Pump	32
LOCTITE® Soft Squeeze Bottles	32
LOCTITE® 10 ml Gel CA Syringe Dispenser	33
LOCTITE® 30 ml Manual Syringe Applicator	33
LOCTITE® 10 ml/30 ml Tube Dispensing Manual Plungers	33
LOCTITE® 50 ml F Tube Squeeze Dispenser	33
LOCTITE® 50 ml Dual Cartridge Manual Applicators	34
LOCTITE® 50 ml Dual Cartridge Pneumatic Applicator	34
LOCTITE® 200 ml/400 ml Dual Cartridge Manual Applicators	34
LOCTITE® 200 ml/400 ml Dual Cartridge Pneumatic Applicators	35
LOCTITE® 400 ml Dual Cartridge Pneumatic Applicator	35
LOCTITE® Fixmaster® Universal Dispenser	35
LOCTITE® Dual Cartridge Manual Applicator 300 ml x 300 ml	33

HANDHELD HOT MELT DISPENSERS

LOCTITE® 050A/050A-HT	37
LOCTITE® 075/075-LT	37
LOCTITE® 175-AIR/175-AIR-HT Pneumatic Dispensers	38
LOCTITE® 175-SPRAY/175-SPRAY-HT Pneumatic Dispensers	38
LOCTITE® 175 Manual Dispenser	39
LOCTITE® Reactive Urethane Cartridge Dispenser	39
LOCTITE® Brand Hot Melt Nozzles & Accessories	40

HANDHELD VALVES

LOCTITE® LV Handheld Applicator	42
LOCTITE® Manual Handheld Applicator	43
LOCTITE® Pneumatic Handheld Applicators	44
LOCTITE® Vari-Drop™ Applicator	45
LOCTITE® Brand Handheld Dispensing Valve Fluid Compatibility Chart	46

DISPENSING VALVES

LOCTITE® Stationary Applicator Valve	48
LOCTITE® Micro Needle Valve	49
LOCTITE® EQ VA10 Micro Diaphragm Valve	50
LOCTITE® Light Cure Dispense Valve	51
LOCTITE® Cyanoacrylate Dispense Valve	51
LOCTITE® EQ VA15 Diaphragm Valve	51
LOCTITE® Diaphragm Valve	52
LOCTITE® Spray Valve	53

LOCTITE® Spray Valve Controller	53
LOCTITE® EQ VA30 Jet Valve	54
LOCTITE® Poppet Valve	55
LOCTITE® EQ Dispense Valve – 50 Bar	56
LOCTITE® High Pressure Dispense Valve – 150 Bar	56
LOCTITE® Brand Valve & Pump Fluid Compatibility Chart	57

ANAEROBIC – SPECIAL DISPENSE SYSTEMS

LOCTITE® Positive Displacement Pump	59
LOCTITE® Rotospray™ 9000 Applicator	59
LOCTITE® Pump-A-Bead™ II Dispenser	60
LOCTITE® Dial-A-Seal® Applicator	61

DISPENSE MONITORING SYSTEMS

LOCTITE® High Precision Dispense Monitoring System	62
----------------------------------------------------------	----

CONSUMABLES

DISPENSE ACCESSORIES

High Precision Stainless Steel Dispense Tips	63
Tapered Dispense Tips	64
General-Purpose Dispense Tips	64
Flexible Dispense Tips	64
General-Purpose Tapered Dispense Tips	64
Additional Dispense Tips & Accessories	64
Cartridge Accessories	64
LOCTITE® Brand Static Mix Nozzles & Accessories	65
LOCTITE® Brand Syringe Accessories	68

DISPENSE SPARE PARTS

LOCTITE® Brand Spare Parts	69
----------------------------------	----

MOTION CONTROL

ROBOT DISPENSE SYSTEMS

LOCTITE® 200D Benchtop Robot	71
LOCTITE® 300D Benchtop Robot	72
LOCTITE® 400D Benchtop Robot	73
LOCTITE® 500D Benchtop Robot	74
LOCTITE® EQ RB20 500D Dual Benchtop Robot	75
LOCTITE® EQ RB15 200D Gantry Robot	76
LOCTITE® S440 Series SCARA-N Robot	77

DISPENSE STATIONS

LOCTITE® EQ RB10 Rotary Dispense System	78
LOCTITE® Brand Mounting Hardware & Guarding Enclosures	79

LIGHT CURE

LIGHT CURE SOLUTIONS

LED LIGHT CURING DEVICES

LOCTITE® 7700 LED Light Source	82
LOCTITE® Indigo® 7703 LED Light Source	82
LOCTITE® 7700-HD LED Light Source	83
LOCTITE® Indigo® 7703-HD LED Light Source	83
LOCTITE® CureJet™ 375 LED	84
LOCTITE® CureJet™ 405 LED	85
LOCTITE® CureJet™ Indigo® LED	86
LOCTITE® CureJet™ Quad Controller	87

LED FLOOD SYSTEMS

LOCTITE® LED Flood Controller	88
LOCTITE® LED Flood Cure, 375	88
LOCTITE® LED Flood Cure, 405	88
LOCTITE® LED Flood Cure, Indigo®	88
LOCTITE® Single Line Array LED, Controller	90
LOCTITE® Single Line Array LED, 365	90
LOCTITE® Single Line Array LED, 405	90

WAND SYSTEMS

LOCTITE® EQ CL10 Single LED Controller	91
LOCTITE® EQ CL10 Quad LED Controller	91
LOCTITE® EQ CL10 6 mm LED Head 2.7 m	91
LOCTITE® EQ CL15 UV Wand Systems	92

CURE CHAMBERS & FLOOD SYSTEMS

LOCTITE® 7401 UV Chamber	93
LOCTITE® 7411-S UV Flood System	94
LOCTITE® Focused UV Flood Curing System	95

CURE CONVEYORS

LOCTITE® 7415 UV Benchtop Conveyor	96
LOCTITE® UV Curing Conveyor	97

HIGH INTENSITY LIGHT SOURCES

LOCTITE® Electrodeless Lamp Assembly & Power Supply	98
LOCTITE® High Intensity Ultraviolet Sources	99

ASSURECURE® SYSTEM

LIGHT METERS

LOCTITE® Radiometer Dosimeter for UV LED and UV A/B Light	101
LOCTITE® Radiometer Dosimeter for Visible LED and UVV Light	101
LOCTITE® 7020 UV Spot Radiometer	102

INDEX

INDEX BY ITEM NUMBER



Equipment Service Solutions

As a full-service supplier of equipment, Henkel offers a wide variety of Equipment Services to its customers.

FACTORY REPAIRS

If you have equipment in need of repair, Henkel can restore it to original operating specifications. Customers often schedule preventive repairs to coincide with annual shutdowns. Henkel can work with you to get your equipment up and running in the fastest possible time frame. Rental equipment may be available on a short-term basis to minimize downtime.

Benefits of Factory Repair Service include:

- Trained technicians evaluate equipment based on original design specifications to identify critical and preventive repair recommendations.
- Equipment is repaired using original factory parts.
- All equipment is fully tested to original quality specifications.
- All repairs carry a 30-day labor and 90-day parts warranty.

CALIBRATIONS

Henkel provides calibration services for all of its light meters. All meters are calibrated to original calibration standards. Data is collected before and after calibration, and a calibration certificate is issued that states test results. In addition, you can sign up with Henkel for calibration reminders. All units are also inspected during calibration for any potential repairs.



FIELD SERVICE

Henkel technicians are available to travel to your location for repair services, preventative maintenance, training or assistance in setting up a new system. Whatever you need, Henkel can provide the service.

SPARE PARTS

Spare parts and accessories are available through the equipment services group of Henkel. Most common spare parts can be identified on our website at www.equipment.loctite.com. If you cannot find the part you are looking for, our equipment services group can help you identify that part and provide you with a quote.

REBUILD EXCHANGE PROGRAM

The Henkel Rebuild Exchange Program offers customers a cost-effective way of streamlining the repair of dispensing valves. The rebuild program allows customers to send in their old valve and receive a reconditioned valve in return. Customers who participate in this program typically keep a spare valve in inventory so if a valve goes down, it can be replaced immediately. The valve in need of repair is then sent to Henkel and a reconditioned valve is shipped back to the customer for future use.



Advantages of the Rebuild Exchange Program are:

- Rebuilt equipment is less than half the cost of a new unit.
- Rebuilt equipment is shipped in one to two business days.
- Highly trained technicians use original factory parts.
- All equipment is specially treated with a Henkel proprietary technology to prolong its useful life with reactive adhesives.
- All rebuilds carry a 30-day labor and 90-day parts warranty.



DISCOUNT EQUIPMENT

Henkel is able to offer a wide range of used or discontinued equipment at discounted prices. This equipment typically has been used in our rental program or has been used for customer demonstrations or trade shows. This equipment may have cosmetic blemishes, but performs to original factory specification. All equipment carries the same warranty as new equipment, and is fully tested and reconditioned prior to sale.



EQUIPMENT RENTAL

Many of the equipment products that Henkel offers are available for short-term rental. Henkel's Equipment Rental Program allows customers the flexibility to confirm the performance of our adhesives and equipment risk-free before investing in a purchase. If, during the first 30 days, you decide that you would like to purchase the rental equipment, the entire rental charge is credited toward your purchase.

The benefits of this program include:

- The performance of a new manufacturing process can be confirmed before investing fully in the purchase of equipment.
- Short production runs can be accommodated without having to buy equipment.
- Equipment can be rented during the repair of production equipment, minimizing any downtime.

LEASE-TO-OWN PROGRAM

Henkel offers a Lease-to-Own program for new equipment. According to the United States Equipment Lessors Association, 80% of all companies use leasing to acquire some or all of the machinery and equipment that they use to run their businesses. Henkel's Lease-to-Own program provides an effective way for your business to acquire almost any Henkel equipment. Leases can be customized to each company's needs. Our program can also include other services and spare parts as part of the equipment lease. Let us customize a lease program to meet your needs.

PREVENTATIVE MAINTENANCE CONTRACTS

There are many misconceptions about preventative maintenance (PM). One such misconception is that PM is unduly costly. This may be true for some components, but not all. Without PM, costs for lost production time from unscheduled equipment breakdown will be incurred. Also, PM will result in savings due to an increase in effective system service life.

Long-term benefits of PM include:

- Improved system reliability.
- Decreased cost of replacement.
- Decreased downtime.
- Better spare part inventory management.

Henkel can create a PM contract that fits your specific equipment and can work with your maintenance staff to ensure maximum uptime of your equipment.

REQUEST EQUIPMENT SERVICES

To learn more about the services Henkel offers, you can visit our website at www.equipment.loctite.com/service. In addition to our services, the website offers manuals and technical information on LOCTITE® equipment products.

By Internet

To request a quote or get more information, email your request to equipment-customerservice@loctite.com.

By Telephone

If you wish to speak to us regarding an equipment service, you can call **860.571.5174** to speak to an equipment services representative.

If you have a question regarding equipment setup or operation, our technical information staff is available to help. To contact a technical information staff member, call **1.800.LOCTITE (562.8483)** and choose the technical service option.

LOCTITE® EQUIPMENT WEBSITE

To better support our wide array of equipment services, our Equipment website provides easy access to all service options and inquiries for all LOCTITE® Equipment you may be interested in. Technical literature, Equipment Showroom locator, operational videos and much more are all at your fingertips, for quick and easy access. You can also choose to purchase directly online using a major credit card. Select from our wide array of adhesive dispensing and light curing equipment. Shipping time for most items is just one to two business days.

Visit us on the web for additional information,
diagrams, products and our full line of equipment.
www.equipment.loctite.com





Dispense Systems – Adhesive Bottles

LOCTITE® bottle dispense systems are designed to offer “the total package” for dispensing adhesives, packaged in a LOCTITE® or any other brand bottle. From out-of-the-box ready to more versatile integrating dispensing components, these systems offer effective solutions to your demanding manufacturing needs.



Dispensing

PRODUCT	Item Number	Pressure Regulation	Used to Dispense	Package Types & Sizes	Viscosity Range	Low Level Sensing	
VOLUMETRIC BOTTLE DISPENSERS – <i>Dispense adhesive directly from product bottle with no reservoirs required.</i>							
	LOCTITE® Benchtop Peristaltic Dispenser	98548	N/A	Instant Adhesives, Light Cure Acrylics, Retaining Compounds, Threadlockers	Any bottle	0 to 5,000 cP	No
PRESSURE-TIME BOTTLE DISPENSE SYSTEMS – <i>Versatile systems for dispensing a wide range of products in a variety of adhesive bottle sizes.</i>							
	LOCTITE® Bond-A-Matic® 3000 Dispenser	982719	0 to 15 psi	Gel Adhesives, Instant Adhesives, Light Cure Acrylics, Retaining Compounds, Threadlockers	250 ml bottle 1 lb. bottle 1 liter bottle	Low	No
	LOCTITE® Bond-A-Matic® 3000 Dispenser	982722	0 to 100 psi		2 kg bottle 200 g squeeze tube	Medium to High	No
	LOCTITE® Integrated Semiautomatic Dispenser	1390322	0 to 15 psi	Gel Adhesives, Instant Adhesives, Light Cure Acrylics, Retaining Compounds, Threadlockers	250 ml bottle 1 lb. bottle 1 liter bottle	Low to Medium	Yes
		1390321	0 to 100 psi		2 kg bottle 200 g squeeze tube	Medium to High	Yes

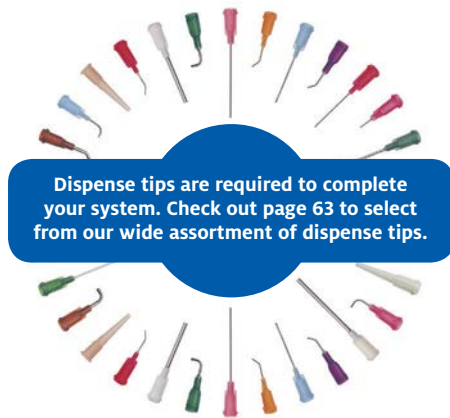

Dispense tips are required to complete your system. Check out page 63 to select from our wide assortment of dispense tips.

VOLUMETRIC BENCHTOP BOTTLE DISPENSER

LOCTITE® BENCHTOP PERISTALTIC DISPENSER

Item Number: 98548

Reliable and effective volumetric dispenser for single-component, low viscosity fluids. Dispenses directly from the product bottle.

Features:

- Air-free volumetric dispensing eliminates air in product, avoiding premature product clogging of cyanoacrylates.
- Instant reverse for vacuum suck-back that shuts off the flow of liquid and prevents dripping.
- Continuous or timed mode with LED display.

TECHNICAL SPECIFICATIONS	
Power Supply	110/220 VAC; 50/60 Hz
Power Consumption	0.3 amps
Dispense Time Range	0.01 to 99.9 seconds
Rotor Speed	Up to 120 rpm
Maximum Flow Rate	Up to 6 ml per minute
Minimum Drop Size	0.001 ml
Dimensions	7.2" W x 3.2" H x 6.7" D
Weight	6.6 lbs.
Used to Dispense	Instant Adhesives, Light Cure Acrylics, Retaining Compounds, Threadlockers
Viscosity	0 to 5,000 cP
Dispense Range	0.001 ml up to 6 ml/minute
Package Types & Sizes	Any bottle
Suck-Back	Programmable by reversing the direction of rotor
Parts Included	(1) Silicone Grease (1) Applicator Assembly (1) Manual (4) Feed Tubing (4) Applicator Nozzles
Additional Information	N/A
Additional Accessories Sold Separately	
	98501 – LOCTITE® Applicator Holder
	1174337 – LOCTITE® Micro Dispense Scale

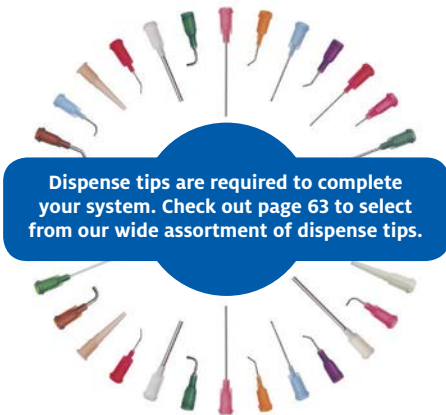

Dispense tips are required to complete your system. Check out page 63 to select from our wide assortment of dispense tips.

PRESSURE-TIME BOTTLE DISPENSE SYSTEMS

LOCTITE® BOND-A-MATIC® 3000 DISPENSER

Item Numbers: 982719 and 982722

Reliable, low-cost pneumatic dispensers for single-component adhesives.

Features:

- Effective “pinch tube” dispenser included.
- PTFE-lined, black feed line provides a light and moisture barrier to ensure no-clog dispensing of light sensitive acrylics and moisture sensitive instant adhesives.
- Dispensing needle assortment allows you to select the needle to deliver the bead or dot size needed for your application.
- Adjustable pressure regulator.

**Ready to Go –
Right Out of the Box!**



LOCTITE® DUAL CHANNEL INTEGRATED DISPENSER

Item Numbers: 1390321 and 1390322

Superior dispensing solution provides cost-effective operation in high volume applications.

Features:

- Integrated fluid reservoir and dispense valve timing controls.
- Precision fluid pressure regulator and gauge.
- Two independent adhesive output ports and digital timing channels (adjustable from 0.01 to 99.99 seconds).
- Can be used to control two dispense valves or one dispense valve and one advancing slide.
- Selectable delay setting allows positioning of an advancing slide prior to the opening of dispense valve.
- Low level sensor alarm provides warning for adhesive bottle replacement.
- Interface connections for customer's PLC to indicate reservoir low level condition and cycle complete signal.
- Selectable supervisory lockouts for pressure and time.



TECHNICAL SPECIFICATIONS

Air Input	Clean, dry air not to exceed 125 psi and filtered with a maximum of 50 microns	
Fluid Pressure Output	982719: 0 to 15 psi	982722: 0 to 100 psi
Product Viscosity	982719: 0 to 3,000 cP	982722: >3,000 cP
Maximum Distance from System to Dispense Point	48"	
Dimensions	<i>Overall</i>	13.125" H x 9.875" W x 14.625" Diameter
	<i>Internal Reservoir</i>	10" H x 5" Diameter
Weight	18 lbs.	
Used to Dispense	Gel Adhesives, Instant Adhesives, Light Cure Acrylics, Retaining Compounds, Threadlockers	
Package Types & Sizes	250 ml bottle / 1 lb. bottle / 1 liter bottle 2 kg bottle / 200 g squeeze tube	
Parts Included	(1) LOCTITE® Bond-A-Matic® Reservoir with 1/4" tank fitting (1) LOCTITE® Vari-Drop™ Applicator Kit (1) 1/4" Feed Line and Spring Strain Relief (1) Anti-Bubble Tip & Sleeve (1) Needle Assortment Kit (1) Tube of Silicone Grease (1) Manual	
Additional Information	For Spare Parts & Accessories, see page 69.	
Additional Accessories Sold Separately		
	994480 – Reservoir Liner	200022 – Empty 1 lb. HDPE Bottle



Dispense tips are required to complete your system. Check out page 63 to select from our wide assortment of dispense tips.

TECHNICAL SPECIFICATIONS

Power Supply	90/260 VAC; 47/63 Hz	
Air Input	Minimum 30 psi	
Fluid Pressure Output	1390321 (0 to 100 psi)	1390322 (0 to 15 psi)
Low Level Sensing	Yes	Yes
Product Viscosity	> 3,000 cP	0 to 3,000 cP
Dimensions	13.3" H x 7.3" W x 14.3" D	
Reservoir Dimensions	4.75" Diameter x 9.75" H	
Weight	15.4 lbs.	
Used to Dispense	Gel Adhesives, Instant Adhesives, Light Cure Acrylics, Retaining Compounds, Threadlockers	
Package Types & Sizes	250 ml bottle / 1 lb. bottle / 1 liter bottle 2 kg bottle / 200 g squeeze tube	
Parts Included	(1) Universal Power Supply (1) Fitting and Tube Kit (1) Dual Channel Integrated Semiautomatic Dispenser	(1) Bottle Nesting Basket (1) Manual (1) Foot Switch (1) Anti-Bubble/Spring Guard Kit
Additional Information	For Spare Parts & Accessories, see page 69.	

Additional Required Accessories Sold Separately

 97132 – LOCTITE® Vari-Drop™ Applicator	 98009 – LOCTITE® Light Cure Dispense Valve	 98013 – LOCTITE® Cyanacrylate Dispense Valve	 97113 / 97114 – LOCTITE® Stationary Applicator Valves
----------------------------------------------------------------------------------------------------------------------------	--------------------------------------------------------------------------------------------------------------------------------	------------------------------------------------------------------------------------------------------------------------------------	---------------------------------------------------------------------------------------------------------------------------------------------

For additional information and the full line of equipment, visit www.equipment.loctite.com.

Dispense Systems – Pneumatic Syringe Dispensing

LOCTITE® pneumatic syringe dispensing systems can accommodate adhesives packaged in either 3, 5, 10, 30 or 55 ml syringe barrels — and conveniently dispense with precision and ease. Our top-of-the-line Posi-Link™ system provides our highest level of dispensing precision, making use of volumetric technology. Other systems use pressure-time dispensing with varying levels of dispensing performance.



PRODUCT	Item Number	Dispense Patterns	Used to Dispense	Package Types & Sizes	Viscosity Range	Vacuum Suck-Back
SYRINGE DISPENSING SYSTEMS – Choose the LOCTITE® Posi-Link™ Volumetric Dispense System for the highest level of dispense precision.						
	See page 9	Dots, Drops, Beads	Gel Adhesives, Instant Adhesives, Light Cure Acrylics, Epoxies	Prepackaged 5 ml syringe 10 ml syringe 25 ml syringe	Low to Paste	Yes
	97006*	Dots, Drops, Beads	Gel Adhesives, Instant Adhesives, Light Cure Acrylics	3 ml syringe 5 ml syringe 10 ml syringe 30 ml syringe 55 ml syringe	Low to Paste	Yes
	1514629	Dots, Drops, Beads	Gel Adhesives, Instant Adhesives, Light Cure Acrylics		Low to Paste	Yes
	883976	Dots, Drops, Beads	Gel Adhesives, Instant Adhesives, Light Cure Acrylics		Low to Paste	Yes
	98050*	Dots, Drops, Beads	Gel Adhesives, Instant Adhesives, Light Cure Acrylics		Low to Paste	Yes
	1464916 1464917 1464918 See Page 13	Dots or Beads	PUR™ Hot Melt Adhesives	30 ml syringe barrels	Low to High	Yes

* Syringe Line Adapter sold separately. See page 68.



Dispense tips are required to complete your system. Check out page 63 to select from our wide assortment of dispense tips.

LOCTITE® POSI-LINK™ VOLUMETRIC DISPENSE SYSTEM FOR PREPACKAGED SYRINGES

The LOCTITE® Posi-Link™ Volumetric Dispensing System is a programmable, volumetric dispensing system that is designed to provide the highest level of dispensing precision directly from a disposable syringe barrel. No need to worry about product temperature or product viscosity changes. This innovative, patent pending design utilizes a “positive link” between a step motor and a mechanical plunger via a noncompressible hydraulic fluid to ensure precise adhesive dispensing down to 0.001 ml drop sizes. See Theory of Operation, page 10.



(Each Item Sold Separately)

LOCTITE® POSI-LINK™ CONTROLLER

Item Number: 98377

Provides all operator interface and control signals to actuator.

Features:

- **Dose selection** by volume.
- **Easy programming** controller, with storage capacity for 25 user-defined programs; reduces adhesive setup waste.
- **Smallest footprint** on the market to conserve benchtop space.
- **Automatic syringe engagement** to ensure easy and error-free syringe changeover.
- **Adhesive level monitoring** with low level visual and digital outputs.
- **Fault detection** with visual and digital outputs for clogged nozzles, loss of pressure, and system faults.
- **In-cycle** visual and digital outputs.
- **Foot switch, finger switch or PLC** remote start activation.



LOCTITE® POSI-LINK™ ACTUATORS

Item Numbers: See chart

Provides adhesive dispensing by effecting incremental movements of syringe piston and displacing programmable quantities of adhesive within syringe barrel.

Features:

- **Flexible orientation** in any position.
- **Easily fits** below an industrial workbench or wall mounts with brackets supplied to conserve benchtop space.
- **Lightweight** remote dispense head has a “positive link” to actuator via a 7-ft. tether, allowing ergonomic handheld dispensing or mounting directly on robotic arms.
- **Easily attaches** to syringe nest (sold separately) to accommodate alternate syringe barrel sizes.
- **Adhesive pressure** is mechanically driven versus traditional air pressure driven, eliminating risk of air infiltration into adhesive.
- **Suck-back** feature prevents drip at end of dispense, and is mechanically driven versus traditional air vacuum-driven, eliminating risk of adhesive being sucked into the system.



The **END** of wetted components and adhesive downloading



Compact controller and floor-mounted actuator leaves bench top wide open for manual applications. See pages 22-23 for more information on LOCTITE® Posi-Link™ actuators for dual cartridge applications.

PRODUCT	LOCTITE® Posi-Link™ 5-25 Actuator	LOCTITE® Posi-Link™ 10-50 Actuator
Item Number	98378	98379‡
Application Type	Recommended for Handheld	Recommended for Mounted or Robotic
Syringe Barrel Size	5, 10, 25 ml	10, 25 ml

‡ See pages 22-23 for use with dual component epoxy cartridges.

LOCTITE® POSI-LINK™ SYRINGE NESTS

Item Numbers: See chart

Connects actuator to syringe barrel.

Features:





- No tool syringe changeover.
- No contact with adhesive: disposable syringes are the only component in contact with the adhesive.
- No adhesive downloading: directly accepts LOCTITE® brand prefilled syringes, plus many other brands.



Also available, 98501 – LOCTITE® Applicator Holder. See page 68.

LOCTITE® Posi-Link™ Syringe Nest Selection			
5 ml Syringe	10 ml Syringe	25 ml Syringe	Used With
98643	98644	98645*	LOCTITE® Posi-Link™ 5-25 Actuator
N/A	98639	98640	LOCTITE® Posi-Link™ 10-50 Actuator

* 98645 can only be used with product viscosity up to 5,000 cP. Use 98379 (actuator) and 98640 (nest) for 25 ml syringes over 5,000 cP. Suitable for handheld applications.

TECHNICAL SPECIFICATIONS			
PRODUCT	 LOCTITE® Posi-Link™ Controller	 LOCTITE® Posi-Link™ 5-25 Actuator	 LOCTITE® Posi-Link™ 10-50 Actuator
Item Number	98377	98378	98379
Power Source	9 ft. communication cable to actuator	100/240 VAC; 47/63 Hz	100/240 VAC; 47/63 Hz
Dimensions	5.375" H x 6" D x 6" W	34" H x 4" D x 5" W	34" H x 4" D x 5" W
Total Weight	2 lbs.	12 lbs.	13 lbs.
Dispense Head Weight	N/A	0.75 lbs.	1.5 lbs.
Air Supply	N/A	40 to 100 psi	40 to 100 psi
Posi-Link™ Electro/Hydraulic Tether	N/A	7 ft.	7 ft.
Minimum Dispense Volume ¹ , Syringe	N/A	0.003 ml	0.003 ml
Dispense Rate ²	N/A	0.008 – 0.4 ml/second	0.008 – 0.4 ml/second
Maximum Cycle Rate	N/A	1 cycle per second	1 cycle per second
Parts Included	(1) Posi-Link™ Controller (1) Foot Switch	(1) Posi-Link™ Actuator (1) 9 ft. Communication Cable	(1) Air Inlet Pressure Regulator/Gauge (2) Wall or Table Mounting Bracket (1) 110 Power Cord (1) Instruction Manual
Additional Information	N/A		
Additional Accessories Sold Separately	 988896 – LOCTITE® Syringe Finger Switch	 1174337 – LOCTITE® Micro Dispense Scale	

¹ Maximum dispense volume is settable to 0.001 ml, but becomes consistent at specified minimum in most applications.
² Maximum dispense rate varies based on adhesive viscosity and needle selection.

LOCTITE® Posi-Link™ Actuator Functionality Diagram

Theory of Operation

A disposable syringe is effectively used as a metering piston/cylinder. Because the syringe barrel is of a known and constant diameter, a given incremental movement of the syringe piston will displace a known volume of adhesive within the syringe barrel. The controller unit is programmable to initiate a dispense cycle at the specific volumetric amount. It controls the electronic signaling that activates the step motor inside the actuator housing. External air pressure provides constant force on the plunger within the dispense head. With the initiation of a dispense cycle, the following three events occur simultaneously:

1. The step motor rotates a programmed number of revolutions, moving the lead screw and increasing the hydraulic volume of the stepping cylinder.
2. Hydraulic fluid flows from the remote dispense head to the stepping cylinder, releasing the plunger within the dispense head to travel downward in a controlled incremental movement.
3. As the dispense plunger travels the controlled increment, it displaces (dispenses) a calculated volume of adhesive from the syringe barrel.

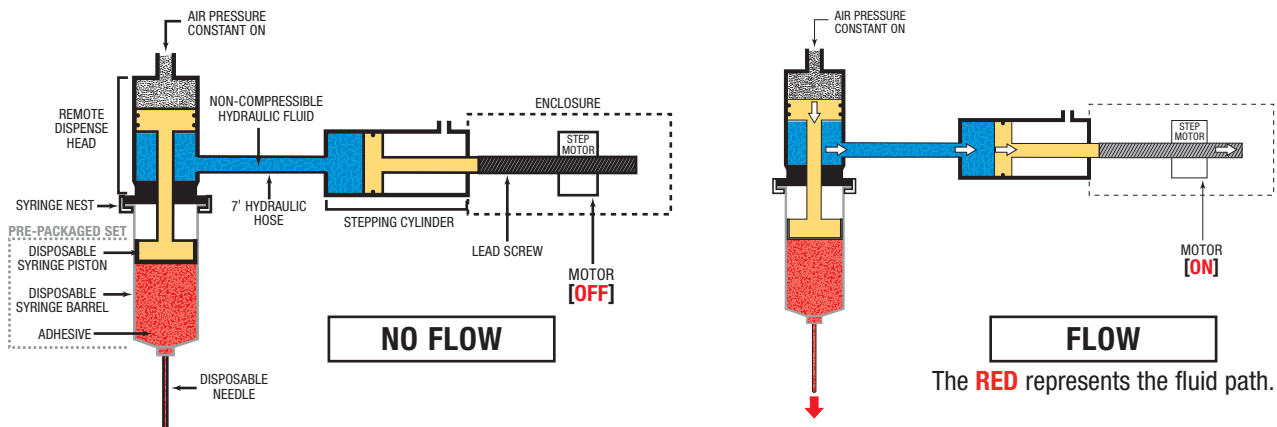

For additional information and the full line of equipment, visit www.equipment.loctite.com.

SYRINGE DISPENSING SYSTEMS

LOCTITE® PRECISION SYRINGE DISPENSING SYSTEM

Item Number: 97006





Our top-of-the-line, pressure-time syringe dispenser.

Features:

- Precision air pressure regulator and digital display ensures consistent results.
- Vacuum suck-back feature prevents dripping and stringing.
- Detects ±10% variation from set pressure and alerts operator if detected.



901459 – LOCTITE® Vertical Syringe Stand

TECHNICAL SPECIFICATIONS	
Power Supply	Selectable 90/260 VAC; 47/63 Hz
Air Supply	Minimum – 30 psi
Pressure Regulator	0 to 100 psi
Product Viscosity	Low to Paste
Dispense Time Range	0.01 to 99.9 minutes
Dimensions	5.9" W x 9.0" H x 10.4" D
Weight	6.17 lbs.
Used to Dispense	Gel Adhesives, Instant Adhesives, Light Cure Acrylics, Retaining Compounds, Threadlockers
Package Types & Sizes	3 ml, 5 ml, 10 ml, 30 ml and 55 ml syringes / 300 ml cartridges
Parts Included	(1) Digital Syringe Controller (1) Foot Switch (1) Power Cord (1) Manual
Air Line Adapters <i>(Required for syringe dispensing, see page 65.)</i>	For 3 ml syringe dispensing: order 98656 For 5 ml syringe dispensing: order 98657 For 10 ml syringe dispensing: order 97208 or 97216 For 30 ml syringe dispensing: order 97245 or 97294 For 55 ml syringe dispensing: order 97245 or 98416
Additional Information	For Syringe Accessories, see pages 68-69. For Dispense Tips, see pages 63-64.
Additional Accessories Sold Separately	
 988896 – LOCTITE® Syringe Finger Switch Assembly. Used in place of the foot switch to allow finger actuation while holding the syringe barrel.	 1174337 – LOCTITE® Micro Dispense Scale
 98501 – LOCTITE® Applicator Holder	 901459 – LOCTITE® Vertical Syringe Stand

LOCTITE® EQ SD10 DIGITAL SYRINGE DISPENSER



Item Number: 1514629

The ideal blend of precision and value in syringe dispensing.

Features:

- Digital time/pressure/vacuum display.
- Easy teach & learn function.
- Manual/Timed/Cycle operation Modes.
- Vacuum suck-back feature ensures no dripping.
- Fast dispense speed 600 cycles/second.
- Stores up to 39 dispense programs.
- The unit can be integrated into customer's PLC programming to initiate a dispense cycle.



TECHNICAL SPECIFICATIONS	
Power Supply	100-240 VAC, 50-60 Hz
Operation Temperature	+50°F to +104°F (+10°C to +40°C)
Dispense Time Range	0.01 to 99.9 seconds
Dimensions	265 mm W x 72 mm H x 211 mm D
Weight	3.0 kg
Used to Dispense	Gel Adhesives, Instant Adhesives, Light Cure Acrylics, Retaining Compounds, Threadlockers
Package Types & Sizes	3 ml, 5 ml, 10 ml, 30 ml and 55 ml syringes / 300 ml cartridges
Parts Included	(1) EQ SD10 Digital Syringe Dispenser (1) Operating Manual (1) Power Supply (1) Foot Switch (1) Syringe Barrel Stand (1) Syringe Test Kit (1) 30/55cc Syringe Air Line Adapter
Air Line Adapters <i>(Required for syringe dispensing, see page 65.)</i>	For 3 ml syringe dispensing: order 98656 For 5 ml syringe dispensing: order 98657 For 10 ml syringe dispensing: order 97208 or 97216 For 30 ml syringe dispensing: order 97245 or 97294 For 55 ml syringe dispensing: order 97245 or 98416
Additional Information	For Syringe Accessories, see pages 68-69. For Dispense Tips, see pages 63-64.
Additional Accessories Sold Separately	
 98501 – LOCTITE® Applicator Holder	 1174337 – LOCTITE® Micro Dispense Scale

For additional information and the full line of equipment, visit www.equipment.loctite.com.

LOCTITE® DIGITAL SYRINGE DISPENSING SYSTEM

Item Number: 883976





Top choice for economical yet effective syringe dispensing.

Features:

- Manual, Incremental and Timed Modes allow a choice of adhesive dispensing methods.
- Vacuum suck-back feature prevents dripping and stringing.
- Convenient “teach mode” to set time required for desired dispense amount or volume.
- The unit can be integrated into customer’s PLC programming to initiate a dispense cycle.
- Units can be stacked securely to save workspace.



901459 – LOCTITE® Vertical Syringe Stand

TECHNICAL SPECIFICATIONS	
Power Supply	Universal Power Supply 110/230 VAC; 50/60 Hz
Air Supply	35 to 100 psi, ¼" FNPT
Pressure Regulator	0 to 100 psi
Product Viscosity	Low to Paste
Dispense Time Range	0.020 to 99.999 seconds
Dimensions	6.0" W x 7.1875" H x 7.6875" D
Weight	2.6 lbs.
Used to Dispense	G, IA, LCD, RC, TL
Package Types & Sizes	3 ml, 5 ml, 10 ml, 30 ml and 55 ml syringes / 300 ml cartridges
Parts Included	(1) Digital Syringe Dispenser with Universal Power Cord (1) Foot Switch with Cord Lock (1) Manual (1) 10 ml & (1) 30 ml Syringe Adapter (1) Syringe Stand (1) 6 mm OD Air Line x 6 ft. (4) Air Supply Fittings (1) Air Line Support Mast (1) Needle Sample Kit
Additional Air Line Adapters <i>(Available for syringe dispensing; see page 65.)</i>	For 3 ml syringe dispensing: order 98656 For 5 ml syringe dispensing: order 98657 For 10 ml syringe dispensing: order 97208 or 97216 For 30 ml syringe dispensing: order 97245 or 97294 For 55 ml syringe dispensing: order 97245 or 98416
Additional Information	For Dispense Tips, see pages 63-64.
Additional Accessories Sold Separately	
 1174337 – LOCTITE® Micro Dispense Scale	 988896 – LOCTITE® Syringe Finger Switch Assembly. Used in place of the foot switch to allow finger actuation while holding the syringe barrel.
 901459 – LOCTITE® Vertical Syringe Stand	 98501 – LOCTITE® Applicator Holder

LOCTITE® FOOT PEDAL DISPENSER



Item Number: 98050

For “hands-free” actuation.

Features:

- Simple hands-free operation.
- Easy-to-read adjustable pressure regulator, 20 to 100 psi.
- Designed as floor unit to eliminate the need for bench space.



TECHNICAL SPECIFICATIONS	
Air Input	60 to 100 psi
Air Output	20 to 100 psi
Product Viscosity	Low to Paste
Vacuum Suck-Back	98050: 1 to 15" Hg vacuum
Dimensions	98050: 8.0" W x 4.675" H x 5.0" D
Weight	98050: 4.1 lbs.
Used to Dispense	G, IA, LCD
Package Types & Sizes	3 ml, 5 ml, 10 ml, 30 ml and 55 ml syringes / 300 ml cartridges
Parts Included	(1) Foot Pedal Dispenser (Air Line Adapter sold separately) (1) Manual
Air Line Adapters <i>(Required for syringe dispensing; see page 65.)</i>	For 3 ml syringe dispensing: order 98656 For 5 ml syringe dispensing: order 98657 For 10 ml syringe dispensing: order 97208 or 97216 For 30 ml syringe dispensing: order 97245 or 97294 For 55 ml syringe dispensing: order 97245 or 98416
Additional Information	For Syringe Accessories, see page 68-69. For Dispense Tips, see pages 63-64.
Additional Accessories Sold Separately	
 901459 – Loctite® Vertical Syringe Stand	 1174337 – Loctite® Micro Dispense Scale
	 98501 – Loctite® Applicator Holder

Dispense Key G = Gel Adhesives IA = Instant Adhesives LCD = Light Cure Acrylics
RC = Retaining Compounds TL = Threadlockers

www.equipment.loctite.com

Visit us on the web for additional information, diagrams, products and our full line of equipment.



LOCTITE® 30 ML PUR™ DISPENSE SYSTEM

The LOCTITE® 30 ml PUR™ Dispense System is a precision dispensing system designed to apply dots or beads of LOCTITE® PUR™ Hot Melt adhesive products packaged in 30 ml syringe barrels. The system precisely controls the amount of air pressure applied to the syringe barrel for a set time period to deliver a consistent amount of adhesive each time the system is actuated. It is designed to be used with LOCTITE® Benchtop Robots or can integrate into any stationary work cell.

System Features:

- **Integrated dispense** time control, pressure control and temperature control features into one system.
- **Two independent temperature** control channels: designed to control either the LOCTITE® 30 ml PUR™ Dispense Head or LOCTITE® 30 ml PUR™ Pre Heater.
- **Digital control** for dispense head and pre heater temperature and dispense timer.
- **Analog air pressure** regulator for syringe pressure control, 0-100 psi (7 bar).
- **Dispense sequence** can be foot switch actuated or externally actuated via another control source like a PLC.
- **Auto dispense mode** for timed dispense control of beads or drops.
- **Manual dispense mode** for variable volume applications.
- **PTFE safety** shroud on dispense head.
- **Reduced material** change over time when used with LOCTITE® 30 ml PUR™ Pre Heater.
- **Optional Tip Heater** for improved performance after return to work.



LOCTITE® 30 ML PUR™ CONTROLLER

Item Number: 1464916

- 1 PUR™-Controller-30 ml Syringe
- 1 Foot switch
- 1 User manual
- 1 Power cord
- 1 6mm Air Feed Line
- 1 4mm Air Feed Line



LOCTITE® 30 ML PUR™ PRE HEATER

Item Number: 1464917

- 1 PUR™-Pre Heater – 30ml
- 1 PUR™-Pre Heater Cable





LOCTITE® 30 ML PUR™ DISPENSE HEAD

Item Number: 1464918

- 1 PUR™-Dispense Head – 30 ml
- 1 Mounting Plate to LOCTITE® Benchtop Robot
- 1 Dispense tip sample kit
- 1 PUR™ Dispensing Head Cable

30 ML PUR SYSTEM TECHNICAL SPECIFICATIONS		
Dispense Time Range	0 – 99.99 seconds	
Air Input	Clean, dry air not to exceed 125 psig (8.5 bar), and filtered with a maximum of 50 micron	
Regulation Range of the Pressure Regulator	0 – 7 bar (0 – 100 PSI)	
Power	Supply: 240 V/50 – 60 Hz, 2.0A Internal: 24 VDC	
Controller Dimensions	Width	250 mm
	Depth	160 mm
	Height	265 mm
	Valve Dimensions	174.2 x 118 x 66 mm
Dispense Head Weight	710 g	
Min Flow Rate (25 ga tip)	1 mg/sec*	
Max Flow Rate (18 ga tip)	73 mg/sec*	

* For reference only, this is not a specification. Flow rates were established dispensing LOCTITE® 3542.

Additional Accessories Sold Separately	
 1667508 – LOCTITE® SD15 Heat Controller	 1667509 – LOCTITE® SD15 Tip Heater
The LOCTITE® SD15 Heat Controller and SD15 Tip Heater are accessories designed for use with the LOCTITE® PUR™ 30 ml dispensing system. They can be integrated with a LOCTITE® Robot and keep the needles warm when the PUR™ dispenser is not being used. This will enhance first piece performance when going back to work.	

SD 15 TECHNICAL SPECIFICATIONS		
Power	Supply: 220VAC/50-60 Hz Internal: 24 VDC	
Dimensions	Width	127 mm
	Depth	194 mm
	Height	73 mm
Operation Temperature	+ 10°C + 40°C	
Storage Temperature	- 10°C + 60°C	
Weight	1.5KG	

Additional Accessories Sold Separately	
LOCTITE® PART NUMBER	DESCRIPTION
985397	LOCTITE® Air Filter, Regulator, Gauge
97201	Foot Switch Assembly
1483249	Needle–All SS, 1/2" 18G, 12 pk.
1483250	Needle–All SS, 1/2" 20G, 12 pk.
1483262	Needle–All SS, 1/2" 21G, 12 pk.
1483264	Needle–All SS, 1/2" 23G, 12 pk.
1483265	Needle–All SS, 1/2" 25G, 12 pk.
1500889	Needle–All SS, 1/2" 19G, 12 pk.

Dispense Systems – Tube Bonding

Henkel offers a system to dispense light cure acrylic adhesives to the outer diameter of tubing.



LOCTITE® LIGHT CURE ACRYLIC ADHESIVE DISPENSING SYSTEM

Item Number: 98445

Effective and uniform coating of light cure acrylic adhesives to the outer diameter of tubing without adhesive getting into the internal surface of the tube.

Adhesive Compatibility

This unit is designed for use with light cure acrylic adhesives only. It should not be used with cyanoacrylates or light cure cyanoacrylates.

Features:

- Bushing design insures no adhesive contamination of internal tube surface.
- Easy adhesive adjustment allows operator to optimize adhesive dispense amount.
- Optional bushings allow a variety of tube diameters.
- Design prevents light exposure of adhesive in the dispenser.
- Built-in adhesive level sight glass.







LCA Tubing Adhesive Applicator Bushing Selection Guide (Standard Bushing)		
Item Number	Description	Tubing OD Range
989038	2 mm (0.079")	0.59" to 0.088"
989039	3 mm (0.118")	0.089" to 0.128"
989040	4 mm (0.157")	0.128" to 0.167"
989041	5 mm (0.197")	0.168" to 0.207"
989042	6 mm (0.236")	0.208" to 0.246"

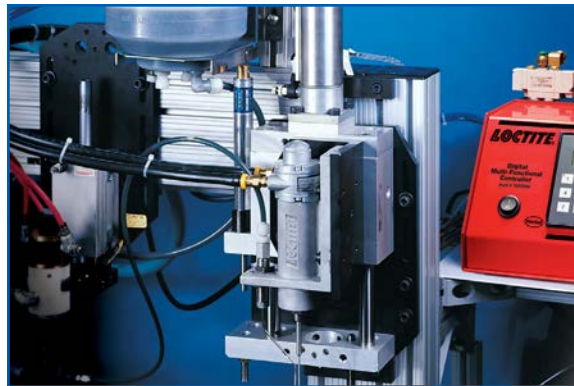

TECHNICAL SPECIFICATIONS	
Utilities	110 VAC; 10 amps; 60 Hz
Overall Dispenser Dimensions	9.0" H x 6.0" Diameter base
Overall Transformer Dimensions	2.3" H x 3.5" W x 4.2" D
Weight	Dispense Unit – 7.7 lbs. / Transformer – 1.25 lbs. (Not Shown)
Adhesive Volume of Dispenser	30 ml
NOT RECOMMENDED FOR TUBING BELOW 70 SHORE A	
Parts Included	(1) Light Cure Acrylic Adhesive Dispensing System (1) Transformer (1) Retaining Ring Pliers (1) Manual (1) Power Cord

Dispense Systems – Controllers & Reservoirs

LOCTITE® brand controllers and reservoirs can be used as the chief components, along with a selection of LOCTITE® brand parts and accessories or with your own parts, to create a complete custom dispensing system designed to meet your specific needs and manufacturing goals. Selection of a LOCTITE® brand controller and reservoir is based on the adhesive or fluid being used, the package or container the adhesive or fluid is supplied in, and the overall requirements of the manufacturing process.



PRODUCT	Item Number	Controlled Outputs	Number of Dispense Valves	Advancing Slide	Rotospray™	
SINGLE FUNCTION CONTROLLERS – Select to operate a single dispense valve.						
	LOCTITE® Digital Dispense Controller	97101	1	1	N/A	N/A
MULTI-FUNCTION CONTROLLERS – Select when you need more functionality than just single valve dispensing.						
	LOCTITE® Dual-Channel Automatic Controller	97152	2	2 (Dependent)	97119 – 100 mm	97115
	LOCTITE® Spray Valve Controller	1406023	1	1	N/A	N/A
	LOCTITE® Digital Multi-Functional Controller	1022006	3	3 (Independent)	984691 – 50 mm	In conjunction with LOCTITE® Positive Displacement Pump – 983330, see page 56.

PRODUCT	Item Number	Pressure Regulation	Used to Dispense	Package Types & Sizes	Viscosity Range	Low Level Sensing
RESERVOIRS – Select your reservoir based on product viscosity and need for low level sensing.						
	982720	0 to 15 psi	Gel Adhesives, Instant Adhesives, Light Cure Acrylics, Retaining Compounds, Threadlockers	250 ml bottle 1 lb. bottle 1 liter bottle 2 kg bottle 200 g squeeze tube	Low to Medium	Yes
	982726					No
	982723	0 to 100 psi			Medium to High	Yes
	982727					No
	98090	0 to 100 psi	Instant Adhesives, Light Cure Acrylics, Retaining Compounds, Threadlockers	250 ml bottle 1 lb. bottle 200 g squeeze tube	Low to High	No

MULTIFUNCTION CONTROLLERS

LOCTITE® DUAL-CHANNEL AUTOMATIC CONTROLLER





Item Number: 97152

The LOCTITE® Dual-Channel Controller is a versatile, multifunction controller for actuating one or two dispensing valves as well as appropriate peripheral equipment such as an advancing slide, rotorspray, and in-line flow monitor or reservoir. Reservoir pressure is controlled by a precision regulator and measured by a digital transducer.

Features:

- Fully programmable, independent controller with permanent software setup.
- Front-mounted keyboard and multilingual display for easy system programming and dispense valve control.
- Digital pressure readout for precise electronic pressure regulation and monitoring of reservoir and valve dispensing.
- Digital time display and control of valve dispensing.
- Capable of controlling one or two dispense valves independently with advancing slide and LOCTITE® Electric RotorSpray unit.



TECHNICAL SPECIFICATIONS	
Power Supply	90/260 VAC; 47/63 Hz
Air Input	58 to 116 psi (4 to 8 bar)
Air Output	1 to 100 psi (0.1 to 7 bar)
Number of Dispense Valves	2 (Independent)
Dimensions	9.0" H x 5.7" W x 10.2" Diameter
Weight	6.5 lbs. (3 kg)
Parts Included	(1) Automatic Controller (1) Pneumatic Tubing, 6 mm O.D. (1) Power Cord (1) Manual
Additional Information	For Dispense Tips, see pages 63-64.
Additional Accessories Sold Separately	
	Bond-A-Matic® 3000 Reservoirs (982720 or 982723)
	97119 – LOCTITE® Advancing Slide (100 mm Stroke)
	97115 – LOCTITE® Electric RotorSpray
	97211 – LOCTITE® High Precision Dispense Monitoring System (See page 62.)

Note: If used with advancing slide, only one dispense valve can be controlled.

LOCTITE® SPRAY VALVE CONTROLLER



Item Number: 1406023

Controller supplies two independent air signals and is designed to work integrally with the LOCTITE® Spray Valve (item 98520).

Features:

- Microprocessor-based timed controller.
- Fully independent valve, open/close and atomization air supply.
- Three separate timed sequences – pre-spray, valve on, post-spray/valve off.
- Timed or manual mode with foot pedal control.
- All time modes maintained in memory with AC power disconnected.



TECHNICAL SPECIFICATIONS		
Power Source	90/260 VAC; 47/63 Hz	
Air Supply	Minimum 30 psi	
Number of Dispense Valves	1	
Dimensions	2.5" H x 12.5" L x 7.6" D	
Weight	5.5 lbs.	
Parts Included	(1) Controller Unit and Power Cord (1) Foot Pedal (1) 4 ft. Air Supply Line and Filter	
Additional Accessories Sold Separately		
 98520 – LOCTITE® Spray Valve	 982720 / 982726 – LOCTITE® Bond-A-Matic® Reservoirs for Low Viscosity Adhesives	989268 – 0.014" Nozzle Kit 989269 – 0.028" Nozzle Kit

LOCTITE® DIGITAL MULTI-FUNCTIONAL CONTROLLER







Item Number: 1022006

Versatile, programmable controller designed to provide on/off digital timing and interface logic for up to three independent dispense/cure devices, pneumatic or electric.

Features:

- Keypad with LCD display to program the on/off times of multiple devices in 0.1 second increments.
- Interface connections for reservoir low level sensors, part present sensors, dispense confirmation sensors, slide position switches, electrical motors, indicator lights, foot switch, anti-tie-down switches, UV and LED curing lights, PLC communication, etc.
- Emergency Stop button on front face of the enclosure.
- Fully modular for optimum system configuration.



TECHNICAL SPECIFICATIONS		
Electrical	Input voltage 100/240 VAC; 50/60 Hz Internal voltage: 24 VDC	
Air Input	60-100 PSI-G, filtered, dry air at 1 CFM (minimum)	
Number of Solenoid Valves	3 (Independent)	
Dimensions	11.375" W x 9.125" D x 8.0" H	
Weight	5 lbs.	
Parts Included	(1) Digital Multi-Functional Controller (1) Foot Switch Assembly (1) 24 VDC Power Supply (1) Manual	
Number of Dry Contact Relay Outputs in Parallel to Solenoids	3	
Additional Information	For Spare Parts & Accessories, see page 69.	
Additional Accessories Sold Separately		
 98009 – LOCTITE® Light Cure Dispense Valve	 98013 – LOCTITE® Cyanoacrylate Dispense Valve	 97113 / 97114 – LOCTITE® Stationary Applicator Valves
 982726 / 982727 – LOCTITE® Bond-A-Matic® Reservoirs	 982720 / 982723 – LOCTITE® Bond-A-Matic® Reservoirs with Low Level Sensors	 1174337 – LOCTITE® Micro Dispense Scale
 1611449 – LOCTITE® EQ VA10 Micro Diaphragm Valve	98083 – LOCTITE® Fluorescence Detector 8900550 – LOCTITE® PLC Interface Cable 1044249 – LOCTITE® Cable Connector Plug Kit	

SINGLE-FUNCTION CONTROLLERS

LOCTITE® DIGITAL DISPENSE CONTROLLER



Item Number: 97101

Digitally timed dispense control for all LOCTITE® brand automatic dispense valves.

Features:

- Convenient touch pad for dispense time control.
- Pneumatic output provides air pressure to a fluid pressure reservoir.
- Fluid low level indicator and output to allow protocol with plant PLC.
- Fully modular for use with the LOCTITE® Bond-A-Matic® Reservoir or the LOCTITE® 300 ml Cartridge Pusher and any dispensing valve.



TECHNICAL SPECIFICATIONS		
Electrical Utilities	90/260 VAC; 47/63 Hz	
Air Input	70 to 145 PSIG filtered (10 micron), dry air at 1 CFM (minimum)	
Number of Dispense Valves	1	
Dimensions	9.5" H x 6.0" W x 11.0" D	
Weight	4.6 lbs.	
Parts Included	(1) Digital Dispense Controller (1) Power Cord (1) Foot Switch Assembly (1) Manual (1) Terminating Plug	
Additional Information	For Spare Parts & Accessories, see page 69.	
Additional Accessories Sold Separately		
 98009 – LOCTITE® Light Cure Dispense Valve	 98013 – LOCTITE® Cyanoacrylate Dispense Valve	 97113 / 97114 – LOCTITE® Stationary Applicator Valves
 98276 / 98277 – LOCTITE® Bond-A-Matic® Reservoirs	 98270 / 98273 – LOCTITE® Bond-A-Matic® Reservoirs with Low Level Sensors	
 1174337 – LOCTITE® Micro Dispense Scale	 1611449 – LOCTITE® EQ VA10 Micro Diaphragm Valve	 97130 – LOCTITE® LV Handheld Applicator

BOTTLE RESERVOIRS

LOCTITE® BOND-A-MATIC® 3000 RESERVOIR





Item Numbers: 982720, 982723, 982726 and 982727

Our most versatile and popular bottle reservoirs for a variety of adhesive viscosity and functionality. All reservoirs require your choice of controller and dispensing valves to complete your dispensing system.

Features:

- Can accommodate a variety of LOCTITE® brand product packages.
- Available with optional low level sensor.
- All pneumatic operation.



TECHNICAL SPECIFICATIONS		
Air Output	982720: 0 to 15 psi	982723: 0 to 100 psi
	982726: 0 to 15 psi	982727: 0 to 100 psi
Product Viscosity	0 to 3,000 cP	> 3,000 cP
Low Level Sensing	982720: 24 VDC	982723: 24 VDC
Dimensions	13.25" H x 9.875" W x 14.125" D	
Internal Reservoir	10" H x 5" Diameter	
Weight	18 lbs. unfilled	
Used to Dispense	Gel Adhesives, Instant Adhesives, Light Cure Acrylics, Retaining Compounds, Threadlockers	
Package Types & Sizes	250 ml, 1 lb., 1 liter, 2 kg bottles / 200 g squeeze tube	
Parts Included	(1) Bond-A-Matic® 3000 Reservoir with ¼" Tank Fitting (1) ¼" Feed Line and Spring Strain Relief (1) Anti-Bubble Tip and Sleeve (1) Squeeze Tube Adapter and Nut/Ferrule (982723 / 982727 only) (1) ⅜" Tank Fitting and Spring Strain Relief (982723 / 982727 only) (1) Manual (1) Tube of Silicone Grease	
Additional Information	For Spare Parts & Accessories, see page 69.	
Additional Accessories Sold Separately		
Any LOCTITE® Brand Dispensing Valve 994480 – Reservoir Liner / 200022 – Empty 1 lb. HDPE Bottle		
	98009 – LOCTITE® Light Cure Dispense Valve	
	97113 / 97114 – LOCTITE® Stationary Applicator Valves	
	1611449 – LOCTITE® EQ VA10 Micro Diaphragm Valve	May be used with all LOCTITE® Controllers; see pages 15-18.

LOCTITE® SHOT MISER™ RESERVOIR





Item Number: 98090

The LOCTITE® Shot Miser™ Reservoir is an economical choice for bottle dispensing operations. It is suitable for a full range of product viscosities, up to 80,000 cP. The reservoir is limited to accept packages no larger than 1 lb. product bottles.

Features:

- A 1 liter internal capacity reservoir; directly accepts product bottles listed in chart.
- Easy-to-read, 0 to 100 psi pressure regulator.
- Pressure/vent valve and hand-tight knobs for easy, no-tool bottle changeover.
- A ¼ in. product feed line connector.



TECHNICAL SPECIFICATIONS		
Pressure Range / Capacity	0 to 100 psi / 1 liter	
Product Viscosity	Low to High	
Dimensions / Weight	13.25" H x 8.5" Diameter / 8.5 lbs.	
Internal Reservoir	7.0" H x 3.75" Diameter	
Used to Dispense	Instant Adhesives, Light Cure Acrylics, Retaining Compounds, Threadlockers	
Package Types & Sizes	250 ml bottle / 1 lb. bottle / 200 g squeeze tube	
Parts Included	(1) Shot Miser™ Liter Reservoir (1) 6 ft. Product Supply Tube (1) Anti-Bubbler Adapter & Sleeve (1) Spring Guard (1) Manual	
Additional Information	For Spare Parts & Accessories, see page 69.	
Additional Accessories Sold Separately		
998353 – Reservoir Liner		200022 – Empty 1 lb. HDPE Bottle
	98009 – LOCTITE® Light Cure Dispense Valve	
	97113 / 97114 – LOCTITE® Stationary Applicator Valves	
	1611449 – LOCTITE® EQ VA10 Micro Diaphragm Valve	May be used with all LOCTITE® Controllers; see pages 15-18.

For additional information and the full line of equipment, visit www.equipment.loctite.com.

Benchtop, Handheld & Soft Pack Cartridge Dispensing

Dispensing from 300 ml cartridges has never been easier when you take charge with our LOCTITE® dispensing systems, designed to support handheld or benchtop operations. Choose your unit based on your process requirements, product chemistry and viscosity as summarized below. Dispense directly from the package with no need for product downloading to syringe or other dispensing containers.



PRODUCT	Item Number	Pressure Regulation	Used to Dispense	Package Types & Sizes	Viscosity Range	Low Level Sensing
PNEUMATIC CARTRIDGE DISPENSING						
	LOCTITE® High Pressure 300 ml Benchtop Cartridge Dispenser 1046901	0 to 725 psi	Silicone, Polyurethane, MS Polymer Adhesives	300 ml cartridges	10,000 to 1,000,000	Yes
	LOCTITE® 300 ml Cartridge Pusher 98022	0 to 50 psi	Gel Adhesives, Anaerobic Gasketing, Light Cure Acrylics, Low Viscosity Silicones	300 ml cartridges 250 ml tubes	Medium	Yes
	LOCTITE® EQ HD10 300 ml Pneumatic Cartridge Dispenser 1714379	0 to 60 psi	Gel Cyanoacrylates, Anaerobic Gasketing, Light Cure Acrylics, Silicones	300 ml cartridges 250 ml tubes	Medium to High	No
	LOCTITE® 300 ml Pneumatic Cartridge Dispensing Retainer 98319A	0 to 60 psi	Gel Cyanoacrylates, Anaerobic Gasketing, Light Cure Acrylics, Silicones	300 ml cartridges	Low to Medium	No
PNEUMATIC SOFT PACK DISPENSING						
	LOCTITE® Soft Press Hand Held Pneumatic Applicator 250052	0 to 125 psi	Adhesives packaged in soft packs	400 ml, 500 ml 20 oz. soft packs	High	No
MANUAL CARTRIDGE DISPENSING						
	LOCTITE® Manual Cartridge Applicator 300 ml 1093940		Henkel Construction Adhesives Caulking products in 10 oz. caulking tubes	300 ml cartridges	Medium to High	Manual

BENCHTOP, HANDHELD & PNEUMATIC SOFT PACK CARTRIDGE DISPENSING

LOCTITE® HIGH PRESSURE 300 ML BENCHTOP DISPENSER

Item Number: 1046901

Very convenient Benchtop Cartridge Dispenser designed for dispensing high viscosity, single-component adhesives and sealants packaged in 300 ml cartridges.

Features:

- High-pressure capability up to 725 psi (50 bar) product pressure.
- Minimal pressure fluctuation results in consistent product flow.
- Pump cycle rate: up to 200 cycles/minute (maximum).
- Up to 10-ft. feedline length.
- Accepts LOCTITE® 300 ml cartridges.
- Product viscosities of 10,000-1,000,000 cP.
- Low level sensing capabilities.

Theory of Operation

This dispenser is an integrated system for dispensing high viscosity materials packaged in 300 ml cartridges. The cartridge dispenser consists of three main components:

1. Pneumatic priming ram is used to provide a low pressure feed of adhesive to the reservoir block.
2. Reservoir block holds the product to be dispensed.
3. A 10:1 pump draws product from the reservoir block and amplifies the pressure by a factor of 10, and then feeds the product through a feedline to the valve.

The unit has two regulators to control the pressure of the pneumatic priming ram and the 10:1 pump. By increasing the pressure of either of these regulators, the outlet pressure of the dispenser will be increased. The primary product regulation should be controlled using the pump regulator, and the pneumatic ram regulator should be set to supply product at just enough pressure to feed the reservoir. The 110-240 VAC power cable plugs to the electrical junction box and supplies power to the 10:1 pump via the low level relay. The low level sensor is mounted to the pneumatic priming ram to indicate when the adhesive cartridge is empty. When activated, the low level sensor will provide a signal to the COM port on the electrical box and turn the 10:1 pump off.

LOCTITE® 300 ML CARTRIDGE PUSHER

Item Number: 98022

Lower viscosity single-component dispenser.

Features:

- Mechanical ram provides product pressure, eliminating risk of inducing air into product, as is the case with pneumatic dispensers.
- Equipped with a low level sensor that can be integrated to a PLC or any LOCTITE® brand digital controller.
- A grease reservoir is included that continually applies a thin film of grease to the plunger shaft to maintain free operation of the ram.
- Integral air pressure regulator/gauge.
- The cartridge retainer can be removed for easy maintenance.
- Can be mounted vertically or horizontally.

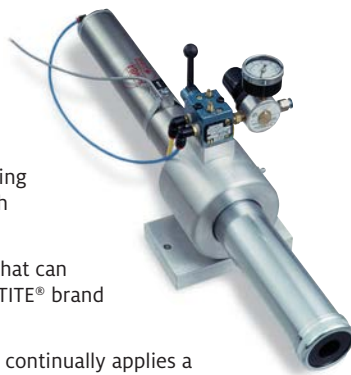

TECHNICAL SPECIFICATIONS	
Input Voltage	110-240 VAC, 50/60 Hz
Rated Power	20 watts
Air Supply	85 psi (6 bar) maximum
Dimensions	14" W x 8.3" D x 27" H
Weight	11 lbs.
Operating Temp.	Temp: -4°F to +120°F (-20°C to +50°C)
Air Consumption	2.9 ft. ³ /min. (80 l/min.) maximum
Replacement Hoses	1241780 and 1241821
Additional Information	N/A



TECHNICAL SPECIFICATIONS	
Air Inlet	1/8" female NPT
Air Input	50 psi maximum
Product Viscosity	Low to Medium Gel Adhesives
Dimensions	8.375" H x 5.8" W x 25.375" Length
Weight	10.6 lbs.
Used to Dispense	Gel Adhesives, Anaerobic Gasketing, Light Cure Acrylics, Low Viscosity Silicones
Package Types & Sizes	250 ml tube / 300 ml cartridge
Parts Included	(1) 300 ml Cartridge Pusher (1) Fitting Kit (1) Manual
Additional Information	For Dispense Tips & Cartridge Accessories, see pages 63-64.
Used With	97101 LOCTITE® Digital Dispense Controller 1022006 LOCTITE® Digital Multi-Functional Controller

LOCTITE® EQ HD10 300 ML PNEUMATIC CARTRIDGE DISPENSER

Item Number: 1714379

Top-choice, handheld 300 ml pneumatic dispenser.

Features:

- Integrated pressure regulator for flow control.



TECHNICAL SPECIFICATIONS	
Air Inputs	145 psi maximum with 300 ml cartridge 22 psi maximum with 250 ml squeeze tubes
Pneumatic Connection	Thread Diameter: ¼" – 19 BSPP
Dimensions	8.0" H x 13.5" L x 1.5" D
Weight	1.8 lbs. (800 g)
Used to Dispense	Gel Cyanoacrylates, Structural Acrylics, Silicones, Anaerobic Flange Sealants
Package Types & Sizes	300 ml cartridges
Parts Included	(1) 300 ml Pneumatic Cartridge Dispenser (1) Manual (1) Quick Disconnect Coupling and Gasket
Additional Information	For Cartridge Accessories, see page 64.
Used With	Direct pneumatic air supply
Additional Accessories Sold Separately	
989347 – Adapter for 250 ml Squeeze Tubes	

LOCTITE® 300 ML PNEUMATIC CARTRIDGE DISPENSER RETAINER

Item Number: 98319A

Mountable pneumatic cartridge dispenser.

Features:

- Quick twist open/close cap.
- 60 psi maximum.



TECHNICAL SPECIFICATIONS	
Air Inputs	70 psi maximum with 300 ml cartridge
Product Viscosity	Low to Medium
Dimensions	10.0" L x 2.5" D
Weight	1.8 lbs. (800 g)
Used to Dispense	Gel Cyanoacrylates, Anaerobic Gasketing, Light Cure Acrylics, Silicones
Package Types & Sizes	300 ml cartridges
Parts Included	(1) 300 ml Pneumatic Cartridge Dispensing Retainer and Cap
Additional Information	For Cartridge Accessories, see page 64.
Used With	883976 LOCTITE® Digital Syringe Dispensing System; see page 12.

LOCTITE® 300 ML SOFT PRESS HAND HELD PNEUMATIC APPLICATOR

Item Number: 250052

High viscosity dispenser for products in soft packs.



Features:

- Drawn Aluminum Barrel
- Instant Air Dump Valve
- Floating Pusher action with Secure Cord
- Adjustable Air Regulator – 125 PSI Max Output
- Silenced Air Exhaust
- Quick Release End Cap



TECHNICAL SPECIFICATIONS	
Air Inputs	145 psi maximum
Pneumatic Connection	Thread Diameter: ¼" – 19 BSPP
Dimensions	21 5/8" L x 9 7/8" H x 2 1/16" D
Weight	1.5 lbs.
Package Types & Sizes	400 ml, 500 ml, 20 oz. Soft Packs
Parts Included	Manual, Applicator Nozzle, Air Hose Connector
Used With	Direct Pneumatic Air Supply
Replacement Parts	582416 – Soft Press Applicator Nozzle

Volumetric Dispensing

LOCTITE® POSI-LINK™ DISPENSE SYSTEM FOR DUAL CARTRIDGES

When you need high precision dispensing from your prepackaged dual cartridge adhesive, the LOCTITE® Posi-Link™ Dispense System is the solution. This system offers dispensing accuracy well beyond any pneumatic cartridge dispenser, down to 0.001 ml drop size. This system specifically excels at eliminating dispense variability due to continuously changing viscosity (curing) in the mix nozzle. It can easily be integrated into any automated process and provide process feedback to a plant PLC. Select your system based on cartridge size and adhesive ratio requirements. You can choose 50 ml packages for any 1:1, 2:1 or 10:1 ratio product.



The **END** of wetted components

Complete LOCTITE® Posi-Link™ Dual Cartridge System		
For 50 ml Dual Cartridges:		
	+	 Actuator +  Nest

(Each Item Sold Separately)

LOCTITE® POSI-LINK™ CONTROLLER

Item Number: 98377

Provides all operator interface and control signals to actuator.

Features:

- **Dose** selection by volume.
- **Easy programming** controller, with storage capacity for 25 user-defined programs; reduces adhesive setup waste.
- **Smallest footprint** on the market to conserve benchtop space.
- **Automatic cartridge engagement** to ensure easy and error-free cartridge changeover.
- **Adhesive level monitoring** with low level visual and digital outputs.
- **Fault detection** with visual and digital outputs for clogged nozzles, loss of pressure and system faults.
- **In-cycle** visual and digital outputs.
- **Foot switch, finger switch or PLC** remote start activation.



LOCTITE® POSI-LINK™ ACTUATOR

Item Numbers: See chart

Provides adhesive dispensing by effecting incremental movements of dual pistons and displacing programmable quantities of adhesive within the cartridge, regardless of viscosity changes in the mix nozzle.

PRODUCT	Item Number	Dual Cartridge Size
LOCTITE® Posi-Link™ 10-50 Actuator	98379*	50 ml

* See pages 9-10 for use with syringes.

Features:

- **Flexible orientation** in any position.
- **Easily fits** below an industrial workbench or wall mounts with supplied brackets to conserve benchtop space.
- **Lightweight** remote dispense head has a “positive link” to actuator via a 7-ft. tether, allowing ergonomic handheld dispensing or mounting directly on robotic arms.
- **Easily attaches** to the dual cartridge nests (sold separately) to accommodate alternate cartridge barrel sizes.
- **Mechanically linked** dual plungers guarantee proper ratios are achieved.
- **Positive shutoff** pinch tube available, which directly attaches to the mix nozzle, eliminating dripping.



LOCTITE® Posi-Link™ 10-50 System, Integrated Robotic Solution using a 50 ml dual cartridge, and showing wall-mounted Actuator.

For additional information and the full line of equipment, visit www.equipment.loctite.com.

LOCTITE® POSI-LINK™ 50 ML DUAL CARTRIDGE NEST

Item Number: See chart

Connects the actuator to the dual cartridge.



Dual Cartridge Nest Features:

- **No tool** cartridge changeover.
- **No contact** with adhesive; disposable syringes are the only component in contact with the adhesive.

LOCTITE® Posi-Link™ Dual Cartridge Nest Selection		
1:1 / 2:1 – 50 ml Cartridge	10:1 – 50 ml Cartridge	USED WITH
98641	98642	98379 – LOCTITE® Posi-Link™ 10-50 Actuator

Theory of Operation

A disposable dual cartridge is effectively used as a dual metering piston/cylinder. Because the individual chambers of a dual cartridge are of a known and constant diameter, a given incremental measurement of the dual pistons will displace a known volume of adhesive within each chamber at an exact ratio. This dual cartridge system functions identically to a LOCTITE® Posi-Link™ Syringe System, except that it has two plungers within the dispense head. These plungers simultaneously act on two chambers within the dual cartridge. See Functionality Diagram on page 10.

LOCTITE® PINCH TUBE VALVE

Item Number: 97141

Features:

- Valve attaches directly to the end of the square mix nozzle.
- Provides positive no-drip shutoff, using disposable pinch tube elements.





FOR 50 ML DUAL CARTRIDGES:

OPTIONAL: 97141 Valve + 97541 (10 pack) Replacement Tube Inserts + 98671 Solenoid Valve

FOR 200/400 ML DUAL CARTRIDGES:

REQUIRED: 97141 Valve + 97541 (10 pack) Replacement Tube Inserts (98671 Solenoid Valve included with Actuator)

TECHNICAL SPECIFICATIONS		
PRODUCT		
	LOCTITE® Posi-Link™ Controller	LOCTITE® Posi-Link™ 10-50 Actuator
Item Number	98377	98379
Power Source	9 ft. communication cable	100/240 VAC; 47/60 Hz
Dimensions	5.375" H x 6" D x 6" W	34" H x 4" D x 5" W
Total Weight	2 lbs.	13 lbs.
Dispense Head Weight (Includes Nest and Pinch Tube Valve)	N/A	2.0 lbs.
Air Supply	N/A	40 to 100 psi
Posi-Link™ Electro/Hydraulic Tether	N/A	7 ft.
Minimum ¹ Dispense Volume	N/A	0.01 ml
Dispense Rate ²	N/A	0.009 – 0.4 ml/ second
Maximum Cycle Rate	N/A	1 cycle per second
Used to Dispense	N/A	All dual 50 ml cartridge 1:1 / 2:1 / 10:1 ratio adhesives
Parts Included	(1) LOCTITE® Posi-Link™ Controller (1) Foot Switch	(1) LOCTITE® Posi-Link™ Actuator (1) 9 ft. Controller/Actuator Signal Cord (1) 110 Power Cord (1) Air Inlet Pressure Regulator Gauge (1) Wall or Table Mounting Bracket (1) Instruction Manual
Additional Information	For Static Mix Nozzles & Accessories, see pages 65-66.	

¹ Minimum Dispense Volume is a machine dispense capability. As with all mix nozzle systems, the minimum possible shot with "proper mixing" is dependent on a properly specified combination of adhesive, mix nozzle and dispense rate.

² Maximum Dispense Rate varies based on adhesive viscosity and mix nozzle selection.



The LOCTITE® Rotor Pump Dispenser (with Controller) is a rotating volumetric displacement system that provides a high level of repeatability while dispensing adhesives out of a product reservoir. The system can apply LOCTITE® products such as anaerobics, acrylates, and UV acrylates for bead, drop, or potting applications with a high level of precision. Designed for use with LOCTITE® benchtop robots, or can integrate into any stationery work cell.

Features:

LOCTITE® Rotor Pump Dispensers

- Product viscosities up to 10,000 mPas.
- Flow rate is proportional to speed and electronically controlled.
- Reversible direction of flow (suck back) allows for exact stoppage of product flow.
- Integrated Luer lock adapter with O-Ring (patented) ensures sealing in reverse flow.

LOCTITE® Rotor Pump Controller

- Provides a wide range of options for adjusting the desired quantity of product to be dispensed.
- All production data can be stored on a SD card and retrieved at any time.
- A graphical user interface is provided for intuitive operator interaction.
- For inline manufacturing, status messages (ready, empty, fault) can be analyzed by a higher ranking controller.

LOCTITE® COMPACT ROTOR PUMP CONTROLLER

Item Number: 1195937

- Compact Rotor Pump Controller
- SD card 256 MB
- Power Adapter



TECHNICAL SPECIFICATIONS	
Power Supply (External Adapter)	100-240 VAC; 1.6A max; 50/60 Hz, 100-200 VA
Power Supply (Controller)	24 V DC
Power Consumption	.05 – 2.7 A
Quality <i>(If the required quality is not achieved, install a LOCTITE® 97120 filter regulator)</i>	Filtered 10µm, oil free, non-condensing Accessory no. 88649
Pneumatic Hose, Control Air Connection O.D.	Ø 6 mm; +.05/- .10
Pneumatic Hose, Product Reservoir O.D.	Ø 6 mm; +.05/- .10
Operating Temperature	+10° C to +40° C (+50° F to +104° F)
Dimensions	240 mm W x ~ 115 mm H x 260 mm D
Weight	1.3 kg
Spare Parts	97120 – Air Supply Filter/Regulator
Accessories	97201 – Foot Switch
	132922 – Robot Interface Cable
	1528963 – Pressure Sensor
	1562190 – Sensor Extension Cord

LOCTITE® COMPACT ROTOR PUMP DISPENSER 4.0

Item Number: 1196160

- Compact Rotor Pump Dispenser with stator and drive unit.
- Mounting tool.
- Feedline OD 6 mm, length 2 m
- Operating manual



TECHNICAL SPECIFICATIONS	
Dimensions	(LxØ): 220 mm x Ø 35 mm
Weight	.380 kg
Volume Per Revolution	Theoretically .05 ml
Accuracy ¹	±1%
Volume Flow	.05 – 6.0 ml/min
Input pressure	0 – 6 bar
Max. Dispensing Pressure	16 – 20 bar
Intrinsic Tightness ²	Approximately 2 bar
Number of Revolutions	0 – 120 rpm
Storage Temperature	-10° C to +60° C (+14° F to 140° F) dry/dust free
Operating Temperature	+10° C to +40° C (+50° F to +104° F)
Spare Parts	1335043 – Repair Kit, consists of 2 O-rings each: 2.9 x .06 (FKM), 13 x 1.25 (FFKM), 13 x 1.5 (FKM), 16 x 1.25 (FKM), 17 x 1.25 (FKM)
	1335041 – Stator with Housing
	1335042 – Pump Unit without Motor
	1335000 – Sealing Set with Housing
Accessories	142646 – ¼" PTFE Lined Tube

Reference Medium: Approximately 1,000 mPas at 20° C.

- 1 Volumetric dosing as absolute deviation relative to one dispenser rotation. Depending on the viscosity of the dispensing medium.
- 2 Maximum dispensing pressure and self-sealing decrease with decreasing viscosity and increase with increasing viscosity.

LOCTITE® COMPACT MICRO ROTOR PUMP DISPENSER 1.0

Item Number: 1741601

- Compact Rotor Pump Dispenser with stator and drive unit
- Mounting tool
- Feedline OD 6 mm, length 2 m
- Operating manual



TECHNICAL SPECIFICATIONS	
Dimensions	(LxØ): 206 mm x Ø 33 mm
Weight	.380 kg
Volume Per Revolution	Theoretically .012 ml
Accuracy ¹	±1%
Volume Flow	.0012 – 1.48 ml/min
Input pressure	0 – 6 bar
Maximum Dispensing Pressure	16 – 20 bar
Intrinsic Tightness ²	Approximately 2 bar
Number of Revolutions	0 – 120 rpm
Storage Temperature	-10° C to +60° C (+14° F to 140° F) dry/dust free
Operating Temperature	+10° C to +40° C (+50° F to +104° F)
Spare Parts	1681290 – Repair Kit, consists of 2 O-rings each: 2.9 x .06 (FKM), 13 x 1.25 (FFKM), 13 x 1.5 (FKM), 16 x 1.25 (FKM), 17 x 1.25 (FKM)
	1681289 – Stator with Housing
	1681291 – Pump Unit without Motor
	1335000 – Sealing Set with Housing
Accessories	142646 – ¼" PTFE Lined Tube

Reference Medium: Approximately 1,000 mPas at 20° C.

- 1 Volumetric dosing as absolute deviation relative to one dispenser rotation. Depending on the viscosity of the dispensing medium.
- 2 Maximum dispensing pressure and self-sealing decrease with decreasing viscosity and increase with increasing viscosity.

Two-Component Volumetric Dispensing – Meter Mix Systems

When your two-part adhesive application takes on a larger dimension, Henkel has the two-component dispense solution with our LOCTITE® meter mix volumetric dispense systems. You can choose either fixed and variable ratio units and, together with a wide selection of accessories, customize your system to meet your application requirements.



PRODUCT	LOCTITE® DuraPump™ Programmable Meter Mix System	LOCTITE® DuraPump™ Pneumatic Meter Mix System
PERFORMANCE SPECIFICATIONS		
Dispense Range	0.21 cc to 26 cc	
Cycle Rate	Up to 20 per minute	
Mix Ratio Range by Volume	1:1 to 10.0:1	
Maximum Product Feed Pressure	2000 psi	
WETTED COMPONENT MAKEUP		
Abrasion Resistant Pumps	Standard	Standard
Mild Steel Pumps	Not Required	Not Required
Inert Pumps	Standard	Standard
DISPENSE VALVES		
Mix Manifold (accepts mix nozzle directly)	Optional	Optional
Handheld Valve with Trigger Pistol Grip	Optional	Optional
SHOT CONTROL CAPABILITIES		
Manual/Operator Controlled Shot	Standard	Standard
Mechanically Adjusted Limit Switch Shot Control	N/A	Standard
Preprogrammed Electronic Shot Size Control	Standard	N/A
Multiple Preprogrammed Shot Size Control	Standard	N/A
Touchscreen Machine Controls	Standard	N/A
OTHER MACHINE FEATURES		
Feed Accumulators for Bulk Package Pressure Feed	Not Required	Not Required
Maintenance Totalizer	Standard	N/A
Low/High Level Sensing Capable	Optional – Low Level Only	N/A
Supervisor Machine Lock-Out	Standard	N/A
Pneumatically Adjustable Flow Control	Standard	Standard
Auto-Purge Capable	Standard	N/A
Foot Switch Controlled	Standard	Standard



LOCTITE® DURAPUMP™ PROGRAMMABLE METER MIX SYSTEMS

All DuraPump™ Systems typically require a two-week lead time for system design and wet testing validation. Complete price quotes required by your Henkel Sales Representative. See page 29 for System Options and Accessories.

The LOCTITE® DuraPump™ Programmable Meter Mix Systems offer superior operating performance and durability for a wide range of two-component adhesive chemistries up to 10:1 ratios. These programmable models provide convenient touch screen digital control for shot size, a choice of five operating modes, and can easily be integrated with a PLC.

Programmable LOCTITE® DuraPump™ Fixed Ratio Systems

Item Number	Mix Ratio	Shot Size Range
1041649	1:1	0.2 to 26 ml
1041644	2:1	0.2 to 20 ml
1041639	4:1	0.2 to 17 ml
1041638	10:1	0.2 to 15 ml
1041635	Custom*	Will vary based on ratio selected

* Custom ratios available from 1:1 up to 9.99:1.

Features:

- A 64-program storage.
- Includes five modes:
 - Single Shot.
 - Continuous.
 - Incremental Mode – Shots can be dispensed without recharging.
 - Sequential Mode – Allows up to eight different size shots in sequence.
 - Remote Mode – Allows a plant PLC to command the shot size.
- No requirement for pump phasing on start-ups; just start up and go.
- Direct flow shutoff, no check valves to repair or replace.
- Accepts external feed systems up to 1,500 psi without extraneous accumulators.
- Proprietary seals and rod treatment provide superior pump wear life, especially well-suited for highly filled materials.
- Available mixing manifold accepts mix nozzles directly, eliminating the need for a valve in many applications.
- Available with optional low level sensors.
- Vertical pump orientation eliminates air bubble accumulation.
- Does not use vacuum to fill pumps, thus preventing air bubble creation.
- Clogged nozzle detection system.
- Reservoir low-level sensor interface.



Shown with Optional Mix Head and Mix Nozzle.

TECHNICAL SPECIFICATIONS	
Utilities	Electric: 110/250 VAC; 50-60 Hz Pneumatic: 80-110 psi
Dimensions	26.5" H x 12.5" W x 12.5" D
Weight	80 lbs.
Dispense Range ¹	0.2 to 26 ml (ratio dependent) – see ratio chart
Cycle Rate	Up to 20/minute
Used to Dispense	Two-Part Epoxies, Two-Part Acrylics, Two-Part Polyurethanes, Two-Part Silicones
Package Types	Any, excluding dual cartridges
Parts Included	1) LOCTITE® DuraPump™ Programmable Meter Mix (1) Foot Switch (1) Night Cap (1) Ratio Cap
Maximum Inlet Pressure	1,500 psi
Maximum Outlet Pressure	1,500 psi
Additional Information	Feed System Options and Accessories are sold separately. See page 29.

¹ Dispense Range is a machine dispense capability. As with all mix nozzle systems, the minimum possible shot with "proper mixing" is dependent on a properly specified combination of adhesive, mix nozzle and dispense rate.

LOCTITE® DURAPUMP™ PNEUMATIC METER MIX SYSTEMS

All DuraPump™ Systems typically require a two-week lead time for system design and wet testing validation. Complete price quotes required by your Henkel Sales Representative. See page 29 for System Options and Accessories.

The LOCTITE® DuraPump™ Pneumatic Meter Mix Systems offer superior operating performance and durability for a wide range of two-component adhesive chemistries, including MMA, up to 10:1 ratios. All of the pneumatic models provide operator shot size control with pneumatic foot pedal or optional handheld trigger-controlled dispense valve.

Pneumatic LOCTITE® DuraPump™ Fixed Ratio Systems

Item Number	Mix Ratio	Shot Size Range
1041648	1:1	0.4 to 26 ml
1041643	2:1	0.4 to 20 ml
1041641	4:1	0.4 to 17 ml
1041637	10:1	0.4 to 15 ml
1041633	Custom*	Will vary based on ratio selected
For MMA Chemistry		
1041647	1:1	0.4 to 26 ml
1041636	10:1	0.4 to 15 ml
1041620	Custom*	Will vary based on ratio selected

* Custom ratios available from 1:1 up to 9.99:1.

Features:

- No electrical power required; ideal for flammable adhesives (MMAs) and remote locations where only compressed air is available.
- No requirement for pump phasing on start-ups; just start up and go.
- Direct flow shutoff, no check valves to repair or replace.
- Systems accept external feed systems up to 1,500 psi without extraneous accumulators.
- Proprietary seals and rod treatment provides superior pump wear life, especially well suited for highly filled materials.
- Mixing manifold discharge accepts mix nozzles directly, eliminating the need for a valve in many applications.
- Vertical pump orientation eliminates air bubble accumulation.
- Does not use vacuum to fill pumps, thus preventing air bubble creation.



Shown with Optional Mix Head and Mix Nozzle.



TECHNICAL SPECIFICATIONS	
Utilities	Pneumatic: 80-110 psi
Dimensions	26.5" H x 12.5" W x 12.5" D
Weight	80 lbs.
Dispense Range ¹	0.4 to 26 ml (ratio dependent) – see ratio chart
Cycle Rate	Up to 20/minute
Used to Dispense	Two-Part MMAs, Two-Part Epoxies, Two-Part Acrylics, Two-Part Polyurethanes, Two-Part Silicones
Package Types	Any, excluding dual cartridges
Parts Included	1) LOCTITE® DuraPump™ Pneumatic Meter Mix (1) Foot Switch (1) Night Cap (1) Ratio Cap
Maximum Inlet Pressure	1,500 psi
Maximum Outlet Pressure	1,500 psi
Additional Information	Feed System Options & Accessories are sold separately. See page 29.

¹ Dispense Range is a machine dispense capability. As with all mix nozzle systems, the minimum possible shot with "proper mixing" is dependent on a properly specified combination of adhesive, mix nozzle and dispense rate.

LOCTITE® BRAND METER MIX SYSTEM OPTIONS & ACCESSORIES

All items sold separately, except where noted.

LOCTITE® DuraPump™ Models

PRODUCT	Item Number	Description	
DURAPUMP™ DISPENSE VALVE (Options)			
	ADHESIVE PARTS A/B VISCOSITY DIFFERENTIAL <6X		
	1167586	Mixing Manifold – All ratios and products, 1,200 cP minimum viscosity, directly connects mix nozzles	
	1051662	Dispense Valve – MMA (All ratios)	
	ADHESIVE PARTS A/B VISCOSITY DIFFERENTIAL >6X		
	1079254	Dispense Valve – General-Purpose (All ratios)	
	1079256	Dispense Valve – MMA (All ratios)	
	VALVE OPTIONS		
	97141	Pinch Tube Valve (Provides positive shutoff at static mixer end, use with mixing manifold)	
	DURAPUMP™ HOSE KIT – 2 required for each dispense valve		
		1051692	Hose for Dispense Valve – 3/8" x 24" General-Purpose
1051670		Hose for Dispense Valve – 3/8" x 24" MMA	
1051669		Hose for Dispense Valve – 3/8" x 96" MMA	
1051694		Hose for Dispense Valve – 3/8" x 144" MMA	
1051668		DuraPump™ Heated Hose Option – 48"	
1051667		DuraPump™ Heated Hose Option – 96"	
1051666		DuraPump™ Heated Hose Option – 144"	
<p>All LOCTITE® DuraPump™ hose kits come complete with two fittings for connection to the DuraPump™ System and Dispense Valve.</p>			

PRODUCT	Item Number	Description
DURAPUMP™ RESERVOIR OPTIONS		
 <p><i>SHOWN: 2 Poly Tanks mounted on 1 Dual Tank Stand</i></p>	1051660	9.5 liter Poly Gravity Tank with Cover (Requires 1051651)
	1051659	7 liter Ni Plated Steel Gravity Tank with Cover (Requires 1051651)
	1051651	Dual Tank Stand (1 Required for each pair of Gravity Tanks)
	1051657	Disposable Desiccant Air Dryer Option
	1051656	Follower Plate with Handle Option (For Ni Plated Steel Tank Only)
	1051655	Agitator Assembly Option (For Ni Plated Steel Tank Only)
	1051654	Tank Heater and Controls Option (For Ni Plated Steel Tank Only)
	1051630	Low Level Sensing Option – Ni Plated Steel Tank (Programmable DuraPump™ Only) – 1 Sensor
	1051629	Low Level Sensing Option – Poly Tank (Programmable DuraPump™ Only) – 1 Sensor
	DURAPUMP™ CONTROL OPTIONS	
1051627	Hose Heat Controller – For 1 or 2 Heated Hoses	
1051695	Precision Hydraulic Flow Controller	

TWO-COMPONENT DISPENSING – AUTOMATIC DUAL CARTRIDGE

LOCTITE® 50 ML DUAL CARTRIDGE DISPENSER, FOR 4:1, 10:1 RATIO, B-STYLE MIX NOZZLES

Item Number: 1444133

LOCTITE® 50 ML DUAL CARTRIDGE DISPENSER, FOR 1:1, 2:1 RATIO, A-STYLE MIX NOZZLES

Item Number: 1444135

The LOCTITE® 50 ml Dual Cartridge Dispenser, when used in conjunction with any LOCTITE® Adhesive Dispensing Robot (sold separately) system, provides a total processing solution for applying small beads or drops. The dispenser also includes a unique, patent-pending, anti-drip valve. This disposable valve connects to the end of the mix nozzle and provides shutoff directly at the dispense tip, allowing immediate and crisp fluid on/off control. The dispenser mounts easily to the robot and can be programmed for any 3-axis application. It can also be used as a stationary dispenser with the use of a LOCTITE® Single Function Controller (item 97101).

Features:

- Independent cartridge pressure and actuation controls to fine-tune adhesive flow rate.
- Lightweight design; able to be used on any LOCTITE® Adhesive Dispensing Robot or as a stationary applicator.
- Dispenses adhesives up to 200,000 cP viscosities.
- Includes Dispense Needle Holder to insure repeatable needle positioning shot after shot.
- All pneumatic operation.

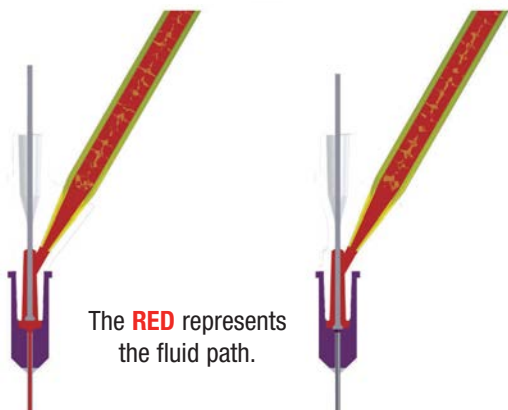
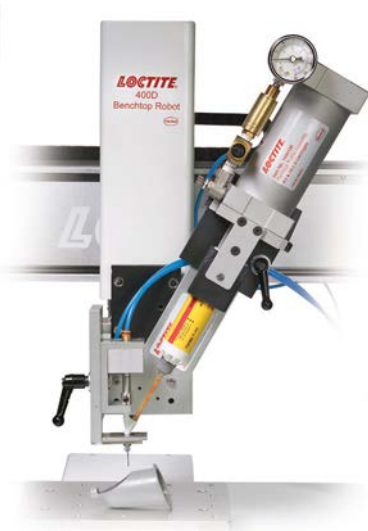

FLOW

NO FLOW

TECHNICAL SPECIFICATIONS

Dimensions	11" L x 14.8" H x 4.6" W	
Weight	5.3 lbs.	
Pneumatic Air Supply	40-80 psi	
Used to Dispense	All dual component adhesive products in 50 ml dual cartridges	
Package Types and Sizes	1444133	4:1, 10:1 B Style 50 ml Dual Cartridges
	1444135	1:1, 2:1 A style 50 ml Dual Cartridges
Parts Included	(1) 50 ml Pneumatic Dispenser (1) Needle Holder 23-27 Gauge	(1) Manual (1) Mounting Hardware to Robot
Required Accessories		

1444139 (500 pack) / 1445944 (100 pack) – Anti-drip Valve



1334299 (100 pack) – Mix Nozzles for 1:1, 2:1, A-style



1440017 (100 pack) – Mix Nozzles for 1:1, 2:1, B-style



1329200 (100 pack) – Mix Nozzles for 4:1, 10:1, B-style



*See ½", 1" or 1½" Stainless Steel Dispensing Needles on pages 63-64.

Handheld Applicators

LOCTITE® brand handheld applicators are ergonomically designed for the hand delivery of adhesives and fluids directly from their original package. Whether pneumatic or manual, each item is designed for the simple, clean, handheld dispensing of fluids, and to reduce waste and operator contact. Selection of a LOCTITE® brand handheld applicator is based on product type, package configuration and process requirements.



PRODUCT		Item Numbers	Used to Dispense	Package Types & Sizes	Viscosity Range	Type
BOTTLE DISPENSING – <i>The most popular handheld bottle top dispensers for LOCTITE® brand threadlockers and other adhesive products.</i>						
	LOCTITE® 50 ml / 250 ml Hand Pumps	98414	Retaining Compounds, Threadlockers	50 ml bottle	Low to Medium	Manual
		97001		250 ml bottle		
	LOCTITE® CA Volumetric Hand Pump	1506477	Cyanoacrylates	20 g or 1 fl. oz. bottle	0.009 to 0.002 grams	Manual
	LOCTITE® Soft Squeeze Bottles	98345	Cyanoacrylates	N/A	Low to Medium	Manual
		98346				
		98347				
SYRINGE DISPENSING – <i>Simple manual dispensers for low volume syringe applications.</i>						
	LOCTITE® 10 ml Gel CA Syringe Dispenser	1233800	Any product package in a standard 10 ml syringe	10 ml syringe	Low to High	Manual
	LOCTITE® 30 ml Manual Syringe Applicator	1544934	Any fluid in a 30 ml syringe, including 25 ml syringes	30 ml syringe	Low to High	Manual
	LOCTITE® 10 / 30 ml Syringe Manual Plungers	98192	Any fluid in a 10 ml syringe	10 ml syringe (3 pack)	Low to High	Manual
		98193	Any fluid in a 30 ml syringe	30 ml syringe (3 pack)		
TUBE DISPENSING – <i>Easy but effective tube dispensing.</i>						
	LOCTITE® 50 ml F Tube Squeeze Dispenser	1083845	Any 50 ml tube	50 ml tubes	Low to High	Manual
TWO-PART DISPENSING – <i>Simple and effective two-part dispensers to meet your lower precision dual cartridge application needs.</i>						
	LOCTITE® 50 ml Dual Cartridge Manual Applicators	98472	Two-Component Epoxies, Urethanes, Methacrylates	50 ml dual cartridge	Low to High	Manual
		1034026				
	LOCTITE® 50 ml Dual Cartridge Pneumatic Applicator	97042	Two-Component Epoxies, Urethanes, Methacrylates	50 ml dual cartridge	Low to High	Pneumatic
	LOCTITE® 50 ml S-Style Dual Cartridge Pneumatic Applicator	1493310	Two-Component Epoxies, Urethanes, Methacrylates, 10:1 ratio	50 ml dual cartridge	Low to High	Pneumatic
	LOCTITE® 200 ml / 400 ml Dual Cartridge Manual Applicators	983436	Two-Component Epoxies, Urethanes, Methacrylates	200 ml dual cartridge	High to Paste	Manual
		983438		400 ml dual cartridge		
		985246		490 ml dual cartridge		
	LOCTITE® 200 ml / 400 ml Dual Cartridge Pneumatic Applicators	983437	Two-Component Epoxies, Urethanes, Methacrylates	200 ml dual cartridge	High to Paste	Pneumatic
		983439		400 ml dual cartridge		
		985249		490 ml dual cartridge		
	LOCTITE® 400 ml Dual Cartridge Pneumatic Applicator	1500890	Two-Component Epoxies, Urethanes, Methacrylates	400 ml dual cartridge	High	Pneumatic
	LOCTITE® Fixmaster® Universal Dispenser	1372751	Two-Component Epoxies, Urethanes, Methacrylates	200 ml and 400 ml dual cartridges	High to Paste	Manual
	LOCTITE® Manual Cartridge Applicator 300 ml	1093940	Henkel Construction Adhesives, Caulking products in 10 oz. caulking tubes	300 ml cartridges	Medium to High	Manual
	LOCTITE® Dual Cartridge Manual Applicator 300 ml x 300 ml	1093981	Henkel Construction Adhesives, 2-Part Epoxy Adhesives	300 ml dual cartridges	Medium to High	Manual

BOTTLE DISPENSING

LOCTITE® 50 ML / 250 ML HAND PUMPS

Item Numbers: 97001 and 98414

Portable, precision, bottle-top applicators that thread directly on any 50 ml or 250 ml bottle of anaerobic product.

Features:

- Adjustable positive displacement, 0.01 ml to 0.04 ml of product.
- Allows user to control amount and positioning of the adhesive.
- Converts product package into a portable dispenser.
- Applicator nozzle accepts a variety of dispensing needles.
- Bottle stand greatly improves 50 ml bottle stability.



TECHNICAL SPECIFICATIONS	
Compatibility	LOCTITE® brand 50 ml or 250 ml anaerobic product bottles
Product Viscosity	Low to Medium
Dimensions (97001)	4" H x 5.75" W x 1.5" Diameter – Pump
Dimensions (98414)	4" H x 5.75" W x 1.5" Diameter – Pump 4.5" H x 3.75" W x 2.25" Diameter – Stand
Used to Dispense	Low Viscosity Thread Sealants, Retaining Compounds and Threadlockers
Parts Included	98414: (1) 50 ml Hand Pump and Stand (1) Needle Kit (1) Manual (1) 988506 – Hand Pump Washers (3 pack) 97001: (1) 250 ml Hand Pump (1) Needle Kit (1) Manual (1) 988506 – Hand Pump Washers (3 pack)
Additional Information	For Dispense Tips, see pages 63-64.

LOCTITE® CA VOLUMETRIC HAND PUMP

Item Number: 1506477

Precision cyanoacrylate dispensing with fingertip control. Get each and every adhesive drop placed exactly where you need it to go. This volumetric, handheld dispenser provides six repeatable shot sizes with its simple stroke adjustment mechanism, and requires no pneumatics, battery or electrical power.

Features:

- Precision cyanoacrylate dispensing from our smallest product bottles.
- Converts product package into a portable dispenser.
- Applicator nozzle accepts a variety of dispensing needles.
- Easy pull trigger and priming design.
- Lightweight and ergonomic design ensures minimal hand fatigue.
- Multiple preset dispense settings provide a range of repeatable shot sizes.
- Compatible with cyanoacrylates and LOCTITE® Flashcure® UV-cyanoacrylates.





TECHNICAL SPECIFICATIONS	
Dimensions	7.5" H x 7.75" W x 2.5" Diameter
Weight	282 g
Used to Dispense	Cyanoacrylates
Packaging Types and Sizes	20 g or 1 fl. oz. bottle
Viscosity Range	1 – 1,500 cP
Drop Size	0.002 – 0.009 g
Parts Included	1506478 – Fluid Element, Black 1506479 – Fluid Element, Clear
Additional Information	For Dispense Tips, see pages 63-64.

LOCTITE® SOFT SQUEEZE BOTTLES

Item Numbers: See chart

LOCTITE® Soft Squeeze Dispense Bottles are intended for use by customers who wish to download LOCTITE® brand cyanoacrylate adhesives from large containers to smaller, handheld packages. These soft, thin-walled polyethylene bottles are ideal for use at manual workstations. A variety of bottle sizes and cap styles are available. Bottles, caps, and dispense tips are sold separately.

TECHNICAL SPECIFICATIONS	
Product Viscosity	Low to Medium
Dimensions	98345 – 3.3" H x 1.5" Diameter
	98346 – 4.3" H x 1.9" Diameter
	98347 – 5.4" H x 2.4" Diameter
Used to Dispense	Cyanoacrylate Adhesives

PRODUCT	Item Number	Description
	98345	2 oz. Soft Squeeze Bottle (50 pack)
	98346	4 oz. Soft Squeeze Bottle (50 pack)
	98347	8 oz. Soft Squeeze Bottle (50 pack)
	98348	Dunce Cap with red sealer cap for 2 oz. bottle (50 pack)
	98349	Dunce Cap with red sealer cap for 4 oz. and 8 oz. bottles (50 pack)
	98350	Luer-Slip Cap for 2 oz. bottle (50 pack)
	98351	Luer-Slip Cap for 4 oz. and 8 oz. bottles (50 pack)

For additional information and the full line of equipment, visit www.equipment.loctite.com.

SYRINGE DISPENSING

LOCTITE® 10 ML GEL CA SYRINGE DISPENSER

Item Numbers: 1233800

The 10 ml Gel CA Syringe Dispenser is a handheld, manually operated dispenser for any product packaged in 10 ml syringes. This dispenser provides a convenient, cost-effective method to apply product.

Features:

- Pistol configuration for ease of application.
- Easy syringe loading.
- Smooth dispensing.
- Lightweight – only 120 grams



TECHNICAL SPECIFICATIONS	
Used to Dispense	Any product package in a standard 10 ml syringe
Package Types & Sizes	10 ml syringes
Viscosity Range	Low to High
Additional Information	For Syringe Accessories, see pages 68-69.

LOCTITE® 30 ML MANUAL SYRINGE APPLICATOR

Item Number: 1544934

Top-choice, handheld, manually operated dispenser.

Features:

- Pistol configuration for ease of application.
- Full-hand trigger minimizes operator fatigue.
- Easy syringe loading.
- Smooth dispensing.



TECHNICAL SPECIFICATIONS	
Used to Dispense	Any fluid in a 30 ml syringe, including 25 ml net fill syringes
Package Types & Sizes	30 ml syringes
Viscosity Range	Low to High
Parts Included	(1) 30 ml Manual Syringe Applicator (1) Manual (1) Plunger
Additional Information	For Dispense Tips, see pages 63-64.

LOCTITE® 10 ML / 30 ML TUBE DISPENSING MANUAL PLUNGERS

Item Numbers: 98192 and 98193

Economical/reusable manual plungers.



TECHNICAL SPECIFICATIONS	
Used to Dispense	All approved 10 ml and 30 ml syringes, including pre-packaged syringes with a 25 ml fill
Package Types & Sizes	10 ml and 30 ml syringes
Viscosity Range	Low to High
Additional Information	For Syringe Accessories, see pages 68-69.

LOCTITE® 50 ML F TUBE SQUEEZE DISPENSER

Item Number: 1083845

Top choice for dispensing all LOCTITE® products in 50 ml tubes.

Features:

- Effective bed dispensing.
- Virtually no product left in tube when empty.



TECHNICAL SPECIFICATIONS	
Used to Dispense	Any LOCTITE® product in 50 ml tube
Package Types & Sizes	50 ml tubes
Viscosity Range	Low to High
Parts Included	(1) 50 ml F Tube Squeeze Dispenser (1) Plunger (1) Nozzle Adapter

TWO-PART DISPENSING

LOCTITE® 50 ML DUAL CARTRIDGE MANUAL APPLICATORS

Item Numbers: 98472 and 1034026

Cost-effective applicators to apply two-part products in 50 ml cartridges.



TECHNICAL SPECIFICATIONS		
Item Number	98472	1034026
Used to Dispense	Two-Component Epoxies, Urethanes, Methacrylates	
Package Types & Sizes	50 ml dual manual cartridge	S-50 cartridge
Viscosity Range	Low to High	
Mix Ratios	1:1 / 2:1 / 4:1 / 10:1	10:1
Parts Included	(1) 50 ml Dual Cartridge Manual Applicator (1) 1:1 Plunger (1) 2:1 Plunger (1) Manual	(1) 50 ml, 10:1-S Cartridge Manual Applicator (1) 10:1-S Plunger
Additional Information	For Static Mix Nozzles & Accessories, see pages 65-67.	
Additional Accessories Sold Separately	984209: 4:1 Plunger 986086: 10:1 Plunger	1 Mix Nozzle available 1034575: 10:1-S Mix Nozzle
Replacement Plungers	983533: 1:1 Ratio 983534: 2:1 Ratio	1034024: 10:1 Ratio

LOCTITE® 50 ML DUAL CARTRIDGE PNEUMATIC APPLICATOR

Item Number: 97042 and 1493310

Pneumatic solution for higher viscosity products.

Features:

- Lightweight, well-balanced design for easy use.
- Versatile cartridge holder accepts dual 50 ml cartridges with 1:1, 2:1 and 10:1 ratios.



TECHNICAL SPECIFICATIONS		
Item Number	97042	1493310
Mix Ratios	1:1 / 2:1	10:1 (B-style only)
Dimensions	14.0" L x 7.6" H x 2.4" D	9.5" L x 9" H x 2.75" D
Weight	1.6 lbs.	1.75 lbs.
Air Supply	30 to 75 psi	20 to 80 psi
Air Supply Fitting	¼" NPT male	¼" to 6 mm tube
Used to Dispense	Two-Component Epoxies, Urethanes, Methacrylates	
Package Types & Sizes	50 ml dual cartridge	
Parts Included	(1) 50 ml Dual Cartridge Pneumatic Applicator (1) Manual	
Viscosity Range	Low to High	
Additional Information	For Static Mix Nozzles & Accessories, see pages 65-67.	

LOCTITE® 200 ML / 400 ML DUAL CARTRIDGE MANUAL APPLICATORS

Item Numbers: 983436, 983438 and 985246

Cost-effective choice for applying products in 200/400 ml cartridges.



TECHNICAL SPECIFICATIONS			
Item Number	983436	983438	985246
Viscosity Range	High to Paste		
Mix Ratios	1:1 / 2:1	1:1 / 2:1	10:1
Used to Dispense	Two-Component Epoxies, Urethanes, Methacrylates		
Package Types & Sizes	200 ml dual cartridge	400 ml dual cartridge	490 ml dual cartridge
Additional Information	For Static Mix Nozzles & Accessories, see pages 65-67.		
Additional Accessories Sold Separately			
984211 – LOCTITE® 4:1 Conversion Kit			

LOCTITE® 200 ML / 400 ML DUAL CARTRIDGE PNEUMATIC APPLICATORS

Item Numbers: 983437, 983439 and 985249

Pneumatic solution for higher viscosity products.



TECHNICAL SPECIFICATIONS			
Item Number	983437	983439	985249
Air Pressure Supply	125 psi (8.5 bar) maximum		
Viscosity Range	High to Paste		
Mix Ratios	1:1 / 2:1	1:1 / 2:1	10:1
Adhesive Components	2	2	2
Used to Dispense	Two-Component Epoxies, Urethanes, Methacrylates		
Package Types & Sizes	200 ml dual cartridge	400 ml dual cartridge	490 ml dual cartridge
Additional Information	For Static Mix Nozzles & Accessories, see pages 65-67.		
Additional Accessories Sold Separately			
984210 – LOCTITE® 4:1 Conversion Kit			

TWO-PART DISPENSING

LOCTITE® 400 ML DUAL CARTRIDGE PNEUMATIC APPLICATOR

Item Number: 1500890

Pneumatic solution for high viscosity products that require a 0-100 psi range capabilities.



TECHNICAL SPECIFICATIONS	
Air Pressure Supply	125 psi (8.5 bar) maximum
Viscosity Range	High
Mix Ratios	1:1 / 2:1
Adhesive Components	2
Used to Dispense	Two-Component Epoxies, Urethanes, Methacrylates
Package Types & Sizes	400 ml dual cartridge
Additional Information	For Static Mix Nozzles & Accessories, see pages 65-67.

LOCTITE® FIXMASTER® UNIVERSAL DISPENSER

Item Number: 1372751

Top-choice, handheld, manually operated dispenser designed for use with two-part adhesives packaged in 200 ml and 400 ml dual cartridges.



TECHNICAL SPECIFICATIONS	
Viscosity Range	High to Paste
Mix Ratios	1:1 / 2:1 / 4:1 / 10:1
Adhesive Components	2
Used to Dispense	Two-Component Epoxies, Urethanes, Methacrylates
Package Types & Sizes	200 ml and 400 ml dual cartridges
Additional Information	For Static Mix Nozzles & Accessories, see pages 65-67.

LOCTITE® DUAL CARTRIDGE MANUAL APPLICATOR 300 ML X 300 ML

Item Number: 1093981

Designed for use with epoxies and sealants packaged in dual 300 ml by 300 ml cartridges. Easily converts to accept 300 ml by 150 ml dual cartridges by changing disk plates. The mechanical advantage of a 26:1 thrust ratio allows for easy application of medium-to-high viscosity materials.



TECHNICAL SPECIFICATIONS	
Mix Ratios	1:1 / 2:1
Dimensions	14.25" L x 4.5" W
Handle Length	5"
Weight	4.25 lbs.
Used to Dispense	Henkel Construction Adhesives, 2-Part Epoxy Adhesives
Additional Information	For Static Mix Nozzles & Accessories, see pages 65-67.

Handheld Hot Melt Dispensers

LOCTITE® handheld hot melt applicators are state-of-the-art dispensing units designed for the application of hot melt adhesives. The model selected should be based on the type of hot melt being used, stick diameter and process requirements.



PRODUCT		Item Number	Stick Diameter	Dispense Melt Rate	Dispense Power	Dispense Temperature	Hot Melt Chemistry
1/2 INCH SUPERSTICK DISPENSERS							
	LOCTITE® 050A Hot Melt Dispenser	916282	1/2" Superstick Sticks	4 lbs./hour	Manual	195°C	EVA/Polyolefin
	LOCTITE® 050A-HT Hot Melt Dispenser	1597635	1/2" Superstick Sticks	4 lbs./hour	Manual	215°C	Polyamide
3/4 INCH MAXISTICK DISPENSERS							
	LOCTITE® 075 Hot Melt Dispenser	98033	3/4" Maxistick Sticks	9 lbs./hour	Manual	182°C	EVA
	LOCTITE® 075-LT Hot Melt Dispenser	98034		5 lbs./hour		121°C	CoolMelt™
1 3/4 INCH SPRAYPAC™ AND POLYSHOT DISPENSERS							
	LOCTITE® 175-AIR Pneumatic Dispenser	98036	1 3/4" Polyshot Sticks	8 lbs./hour	Electric	195°C	EVA/Polyolefin
	LOCTITE® 175-AIR-HT Pneumatic Dispenser	98040				215°C	
	LOCTITE® 175-SPRAY Pneumatic Dispenser	98037	1 3/4" SprayPac™ Sticks	8 lbs./hour	Electric	195°C	Polyamide
	LOCTITE® 175-SPRAY-HT Pneumatic Dispenser	98041				215°C	
	LOCTITE® 175 Manual Dispenser	98035	1 3/4" Polyshot Sticks	6.6 lbs./hour	Manual	195°C and 215°C**	EVA/Polyolefin and Polyamide
URETHANE DISPENSER							
	LOCTITE® Reactive Urethane Cartridge Dispenser	98011	N/A	3 lbs./hour	Air	121°C	Reactive Urethane

** The LOCTITE® 175 Dispenser (manual electric) is supplied with both temperature modules.

½ INCH SUPERSTICK DISPENSERS

LOCTITE® 050A / 050A-HT HOT MELT DISPENSERS

Item Numbers: 916282 and 1597635

Dispenses LOCTITE® industrial grade ½ in. stick.

Features:

- Lightweight and well-balanced, with ergonomically designed easy pull triggers for operator comfort and application control.
- Fixed precision thermostat temperature control for consistent heating.



Item 916282 –
For EVA and Polyolefins



Item 1597635 –
For Polyamide

TECHNICAL SPECIFICATIONS			
PRODUCT		LOCTITE® 050A	LOCTITE® 050A-HT
Item Number		916282	1597635
Required Utilities	Voltage	120 VAC; 60 Hz; single phase	
	Power	250 watts	
Nominal Stick Diameter		½" Superstick	
Size		2.0" W x 12.0" L x 6.5" H	3.0" W x 9.5" L x 8.5" H
Weight		1.25 lbs.	2.2 lbs.
Dispense Power		Manual	
Power Cord Length		6.0 ft. (72")	
Warm-Up Time		3 to 5 minutes	4 to 5 minutes
Dispense Melt Rate		4 lbs./hour	4.4 lbs./hour
Dispense Temperature		193°C	215°C
Hot Melt Chemistry		EVA and Polyolefin hot melts	Polyamide hot melts
Parts Included		(1) 050, 050-HT or 050A Hot Melt Applicator (1) Manual (1) Standard Nozzle (1) Plastic Stand	
Additional Information		For Hot Melt Nozzles & Accessories, see page 40.	

¾ INCH MAXISTICK DISPENSERS

LOCTITE® 075 / 075-LT HOT MELT DISPENSERS

Item Numbers: 98033 and 98034

Dispenses LOCTITE® industrial grade ¾ in. stick.

Features:

- Lightweight, well-balanced, and ergonomically designed for operator comfort and application control.
- Full-hand trigger for minimized operator fatigue.
- Completely enclosed heater housing for maximum safety.
- Fast heat up time for virtually immediate use.
- Highest output, handheld dispenser in its class.
- Fixed precision thermostat temperature control for consistent heating.
- Thermal fuse protection for additional safety.
- Multiple stick loading with a detachable top-mounted speed loader (included).



TECHNICAL SPECIFICATIONS			
PRODUCT		LOCTITE® 075	LOCTITE® 075-LT
Item Numbers		98033	98034
Required Utilities	Voltage	120 VAC; 60 Hz; 120V; 3.3 amp single phase	
	Power	400 watts	
Nominal Stick Diameter		¾" Maxistick	
Size		1.94" W x 12.5" L x 8.25" H	
Weight		1.9 lbs.	
Power Cord Length		6.5 ft. (78")	
Maximum Extension Cord		65 ft.	
Warm-Up Time		5 minutes	
Dispense Power		Manual	
Dispense Melt Rate		9 lbs./hour	5 lbs./hour
Dispense Temperature		182°C	121°C
Applicator Adhesive Capacity		0.12 lbs.	
Wire Cross-Section		16 a.w.g. minimum	
Hot Melt Chemistry		EVA hot melt sticks	LOCTITE® Hysol® CoolMelt™ EVA hot melt sticks
Parts Included		(1) 075 or 075-LT Applicator (1) Plastic Dispenser Stand (2) Stand-Off Wings	(1) Speed Loader (1) Standard Nozzle (1) Manual
Additional Information		For Hot Melt Nozzles & Accessories, see page 40.	

For additional information and the full line of equipment, visit www.equipment.loctite.com.

1¾ INCH SPRAYPAC™ & POLYSHOT DISPENSERS

LOCTITE® 175-AIR / 175-AIR-HT PNEUMATIC DISPENSERS

Item Numbers: 98036 and 98040

Industrial grade, handheld pneumatic hot melt applicator used for dispensing 1.75 in. diameter EVA and polyamide sticks. The operating temperature of the unit is set at 195°C. The dispense rate is controlled by the air pressure and the timing is controlled by the trigger mechanism.

Features:

- Pneumatically powered actuation to reduce operator fatigue.
- High melt rate for maximum output.



TECHNICAL SPECIFICATIONS			
PRODUCT		LOCTITE® 175-AIR	LOCTITE® 175-AIR-HT
Item Numbers		98036	98040
Required Utilities	Voltage	110/120 VAC; 50/60 Hz	
	Power	500 watts	
	Air Input	45 to 100 psi	
Nominal Stick Diameter		1¾" Polyshot	
Size		2.6" W x 12.1" L x 9.5" H	
Weight		3.89 lbs.	
Power Cord Length		10 ft. (120")	
Maximum Extension Cord		65 ft.	
Warm-Up Time		10 minutes	
Dispense Power		Electric	
Dispense Melt Rate		8.8 lbs./hour	
Dispense Temperature		195°C	215°C
Applicator Adhesive Capacity		0.125 lbs.	
Wire Cross-Section		16 a.w.g. minimum	
Hot Melt Chemistry		EVA hot melt sticks	Polyamide hot melts sticks
Parts Included		(1) 175-AIR or 175-AIR-HT Applicator (1) Plastic Stand (1) Valve Body Air Line Adapter (1) Standard Nozzle (1) Manual	
Additional Information		For Hot Melt Nozzles & Accessories, see page 40.	
Additional Accessories Sold Separately			
		 985397 – LOCTITE® Air Line Filter, Regulator/Gauge	

LOCTITE® 175-SPRAY / 175-SPRAY-HT PNEUMATIC DISPENSERS

Item Numbers: 98037 and 98041

Industrial grade, handheld pneumatic hot melt applicator used for dispensing 1.75 in. diameter spray EVA and polyamide sticks. An adjustable air pressure control can vary the spray pattern from narrow to a wide spiral spray.

Features:

- Adjustable flow control for tailoring the spray pattern.
- Patented spray technology for small or large spray pattern.
- Automatic end-of-cycle purge to prevent nozzle clogging.
- Pneumatically powered actuation to reduce operator fatigue.
- High melt rate for maximum output.



TECHNICAL SPECIFICATIONS			
PRODUCT		LOCTITE® 175-SPRAY	LOCTITE® 175-SPRAY-HT
Item Numbers		98037	98041
Required Utilities	Voltage	110/120 VA; 50/60 Hz	
	Power	500 watts	
	Air Input	45 to 100 psi	
Spray Pattern		Ultra-wide spray nozzle: 1.5" minimum / 6" maximum	
		Standard medium spray nozzle: 1.25" minimum / 5" maximum	
		Narrow spray nozzle: 0.5" minimum / 1.25" maximum	
Nominal Stick Diameter		1¾" SprayPac™ Sticks	
Size		2.6" W x 12.1" L x 9.5" H	
Weight		4 lbs.	
Power Cord Length		10 ft. (120")	
Maximum Extension Cord		65 ft.	
Warm-Up Time		10 minutes	
Dispense Power		Electric	
Dispense Melt Rate		8 lbs./hour	
Dispense Temperature		195°C	215°C
Applicator Adhesive Capacity		0.125 lbs.	
Wire Cross Section		16 a.w.g. minimum	
Hot Melt Chemistry		EVA spray hot melt sticks	Polyamide spray hot melt sticks
Parts Included		(1) 175-SPRAY or 175-SPRAY-HT Applicator (1) Plastic Stand (1) Valve Body Air Line Adapter (1) Manual (1) Standard Wide Spray Nozzle	
Additional Information		For Hot Melt Nozzles & Accessories, see page 40.	
Additional Accessories Sold Separately			
		 985397 – LOCTITE® Air Line Filter, Regulator/Gauge	

1¾ INCH SPRAYPAC™ & POLYSHOT DISPENSERS

LOCTITE® 175 MANUAL DISPENSER

Item Number: 98035

Industrial grade, handheld hot melt applicator used for dispensing 1.75 in. diameter without pneumatic assist. The unit includes a plug-in thermostat at 195°C for EVA hot melts and a plug-in thermostat at 215°C for polyamide hot melts.

Features:

- Includes two plug-in modules for dispensing both polyamide and EVA hot melts.
- Advanced electronic controller provides power saving mode when not in use for long periods of time.



TECHNICAL SPECIFICATIONS		
Required Utilities	Voltage	110/120 VAC; 50/60 Hz
	Power	400 watts
Nominal Stick Diameter	1.75" Polyshot Sticks	
Size	2.67" W x 12.25" L x 9.63" H	
Weight	2.65 lbs.	
Power Cord Length	10 ft. (120")	
Maximum Extension Cord	65 ft.	
Warm-Up Time	5 to 7 minutes	
Dispense Power	Manual	
Dispense Melt Rate	6.6 lbs./hour	
Dispense Temperature	195°C or 215°C	
Applicator Adhesive Capacity	0.125 lbs.	
Wire Cross Section	16 a.w.g. minimum	
Hot Melt Chemistry	EVA and polyamide hot melt sticks	
Parts Included	(1) 175 Applicator (1) Plastic Stand (1) Plug-In Module (195°C)	(1) Plug-In Module (215°C) (1) Standard Nozzle (1) Manual
Additional Information	For Hot Melt Nozzles & Accessories, see page 40.	

URETHANE DISPENSER

LOCTITE® REACTIVE URETHANE CARTRIDGE DISPENSER

Item Number: 98011

The 98011 handheld dispensing gun for 300 ml cartridges is used to manually dispense dots or beads of reactive polyurethane hot melts. The system includes a pressure-regulating stand with optional vertical application stand and foot switch for hands-free application.

Features:

- Rugged molded thermoset plastic housing for "cool-to-the-touch" operation up to 121°C.
- Fixed precision temperature: 121°C.
- Single cartridge loading.
- Direct nozzle cartridge mounting for quick cartridge change-over.



TECHNICAL SPECIFICATIONS		
Required Utilities	Voltage	120 VAC; 60 Hz; single phase
	Power	400 watts
	Air Input	80 psi air, filtered to 40 micron
Size	3.1" W x 12.5" L x 10.3" H	
Weight	3 lbs.	
Adhesive	Dispenses 300 cc aluminum cartridge	
Air Output	Maximum 90 psi	
Warm-Up Time	7 to 10 minutes	
Dispense Power	Air	
Dispense Melt Rate	3.5 lbs./hour	
Dispense Temperature	250°F (121°C)	
Applicator Adhesive Capacity	0.125 lbs.	
Hot Melt Chemistry	LOCTITE® Hysol® reactive urethane hot melts	
Parts Included	(1) Reactive Urethane Cartridge Dispenser (1) Base with Regulator and Gauge (1) 300 cc Cartridge Adapter (1) Heat-resistant Gloves (1) Tubing Assembly	(1) Wire Stand (1) Nozzle with Cap (1) Cartridge Piercer (1) Manual
Additional Information	For Hot Melt Nozzles & Accessories, see page 40.	





LOCTITE® BRAND HOT MELT NOZZLES & ACCESSORIES

PRODUCT	Item Number	Description	Used With
	1611450	Replacement Nozzle/Check Valve	1597635
	419115 (SINGLE PACK)	Adapter/Check Valves for Nozzles	98035, 98036, 98040
	916050 (5 PACK)		916282
	ANZ023N01	Standard Nozzle Adapter with Check Valve and Jam Nut	98033, 98034
	985225 (5 PACK)	1-Hole Nozzle 0.08" diameter cone tip (5 pack)	98033, 98034, 98035, 98036, 98040
	985110	2-Hole Nozzle 0.06" diameter x 0.39" spacing	98033, 98034, 98035, 98036, 98040, 98544, 98545
	985111	3-Hole Nozzle 0.06" diameter x 0.20" spacing	98033, 98034, 98035, 98036, 98040, 98544, 98545
	985112	Diagonal Extension Nozzle Tip = 0.14" diameter x 1.23" long	98033, 98034, 98035, 98036, 98040, 98544, 98545
	985113	Needle Extension Nozzle Tip = 0.05" diameter x 1.32" long	98033, 98034, 98035, 98036, 98040, 98544, 98545
	985114	Spreader Extension Nozzle Tip = (0.09" x 0.25") x 1.32" long	98033, 98034, 98035, 98036, 98040, 98544, 98545
	985115	L-Nozzle 0.06" diameter x 0.85" offset	98033, 98034, 98035, 98036, 98040, 98544, 98545
	985122	Standard Medium Spray Nozzle 1.25" to 5" diameter pattern	98037, 98041
	985211	Narrow Spray Nozzle 0.05" to 1.25" diameter pattern	98037, 98041
	985216	Ultra-Wide Spray Nozzle 1.5" to 6.0" diameter pattern	98037, 98041
	984261	Standard Adapter for 300 ml Cartridges	98011
	984262	Standard 1-Hole Nozzle 0.098" diameter cone tip, with integral check valve (includes protective cap)	98011
	984263	Adapter/Check Valve for Specialty Nozzles	98011
	984264	Needle Jet Nozzle Tip = 0.051" diameter x 1.26" long (requires 984263 adapter)	98011
	984268	3-Hole Nozzle 0.06" diameter x 0.20" spacing (requires 984263 adapter)	98011
	984272	Injection Needle Nozzle with Integral Check Valve Tip = 0.059" diameter x 0.197" long	98011
	985397	Air Line Filter, Regulator, 5 Micron Filter Gauge 0 to 150 psi	All Pneumatic Applicators

Handheld Valves

LOCTITE® brand handheld dispensing valves are used where ergonomic design for hand dispensing of fluids is desired. Designed for use with LOCTITE® brand controllers and reservoirs, these handheld valves use passive wetted components for universal compatibility with many fluids. Selection of a LOCTITE® brand handheld valve is based on the desired dispensing controls, the dispense principal of the delivery system and other process requirements.



PRODUCT	Item Number	Type	Viscosity Range	Dispense Patterns	Used to Dispense	Stroke Adjustment	Actuation	
LOW VISCOSITY CYANOACRYLATE APPLICATOR								
	LOCTITE® LV Handheld Applicator	97130	Pneumatic	Low	Drop, Dot, Bead	Instant Adhesives, Retaining Compounds, Threadlockers	Yes	Foot
GENERAL-PURPOSE APPLICATORS								
	LOCTITE® Manual Handheld Applicator	97111	Manual	Low to Medium	Drop, Dot, Bead	Light Cure Acrylics, Retaining Compounds, Threadlockers	Yes	Finger
	LOCTITE® Pneumatic Handheld Applicator	97112	Pneumatic	Low to Medium	Drop, Dot, Bead	Light Cure Acrylics, Retaining Compounds, Threadlockers	Yes	Foot
	LOCTITE® Pneumatic Handheld Applicator	97116	Pneumatic	Low to Medium	Drop, Dot, Bead	Light Cure Acrylics, Retaining Compounds, Threadlockers	Yes	Finger
PINCH TUBE APPLICATORS								
	LOCTITE® Vari-Drop™ Applicator	97131	Pinch Tube	Low to Medium	Drop, Dot, Bead	Instant Adhesives, Retaining Compounds, Threadlockers	Yes	Finger
		97132						

LOW VISCOSITY CYANOACRYLATE APPLICATOR

LOCTITE® LV HANDHELD APPLICATOR

Item Number: 97130

Our most precise handheld applicator for cyanoacrylate adhesives. Sleek ergonomic design provides terrific operator comfort and control.

Features:

- Dispenses low viscosity cyanoacrylates, anaerobic and other adhesives under 10,000 cP.
- Slim, ergonomic design greatly reduces hand fatigue.
- Forward closing to avoid air entrapment and potential premature curing of cyanoacrylates.
- Stroke adjustment for fine-tuning of dispense characteristics.
- Dispenses repeatable drop sizes down to 0.005 g.
- Easy repair/replacement of wetted components.

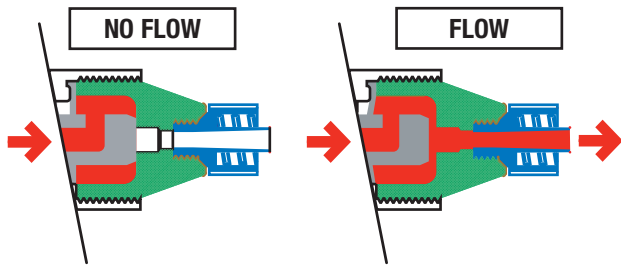







The RED represents the fluid path.

TECHNICAL SPECIFICATIONS

Type	Pneumatic
Viscosity Range	Low
Size	7" L x 1.6" Maximum Diameter (170 mm L x 40 mm Maximum Diameter)
Weight	5 oz. (140 g)
Maximum Cycle	2 shots per second
Port Size	Fluid Inlet – ¼" Tubing
Air Inlet	5/32" Tubing
Fluid Pressure	4 to 30 psi (0.25 to 2 bar)
Pneumatic Supply	Minimum: 60 psi (4.8 bar) / Maximum: 100 psi (7 bar)
Dispense Patterns	Drop, Dot, Bead
Used to Dispense	Instant Adhesives, Retaining Compounds, Threadlockers
Stroke Adjustment	Yes
Actuation	Foot
Parts Included	(1) 2 m Product Feed Line, PTFE-lined, ¼" OD (1) LV Handheld Applicator (1) 2 m Pneumatic Tubing (1) Needle Variety Kit (1) Silicone Grease (1) Manual
Additional Information	For Spare Parts & Accessories, see page 69. For Fluid Compatibility Selector Chart, see page 46.

Additional Accessories Sold Separately

 98090 – LOCTITE® Shot Miser™ Reservoir	 98501 – LOCTITE® Applicator Holder	 97101 – LOCTITE® Digital Dispense Controller
 1174337 – LOCTITE® Micro Dispense Scale	 1390321 / 1390322 – LOCTITE® Integrated Semiautomatic Controllers with Low Level Sensor	 982720 / 982723 / 982726 / 982727 – LOCTITE® Bond-A-Matic® Reservoirs



Dispense tips are required to complete your system. Check out page 63 to select from our wide assortment of dispense tips.

GENERAL-PURPOSE APPLICATORS

LOCTITE® MANUAL HANDHELD APPLICATOR

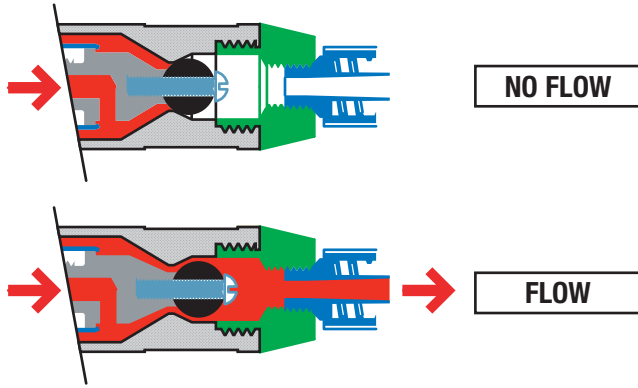

Item Number: 97111

Our versatile yet cost-effective pressure time dispense valve with fingertip dispense activation control.



The **RED** represents the fluid path.



TECHNICAL SPECIFICATIONS	
Type	Manual
Viscosity Range	Low to Medium
Size	1.12" D x 5.2" L x 2.74" W
Weight	3.5 oz. (99.2 g)
Air Input	60 psi minimum
Product Inlet	¼"
Wetted Components	Acetal Copolymer, PTFE, PTFE Coated Metal
Dispense Patterns	Drop, Dot, Bead
Used to Dispense	Light Cure Acrylics, Retaining Compounds, Threadlockers
Stroke Adjustment	Yes
Actuation	Foot
Parts Included	(1) Handheld Applicator (1) Applicator Grip (1) Trigger Lever (1) Needle Kit (1) Manual
Additional Information	For Spare Parts & Accessories, see page 69. For Fluid Compatibility Selector Chart, see page 46. For Dispense Tips, see pages 63-64.
Additional Accessories Sold Separately	
 98501 – LOCTITE® Applicator Holder	 982726 / 982727 – LOCTITE® Bond-A-Matic® Reservoirs
97220 – ⅜" Feed Line Kit	

GENERAL-PURPOSE APPLICATORS

LOCTITE® PNEUMATIC HANDHELD APPLICATOR

Item Number: 97112 – Foot Switch Activated

Step up to pneumatic dispense actuation support with either foot pedal or ergonomic design trigger control.



LOCTITE® PNEUMATIC HANDHELD APPLICATOR

Item Number: 97116 – Finger Switch Activated

Step up to pneumatic dispense actuation support with either foot pedal or ergonomic design trigger control.



Features of Pneumatic Handheld Applicators:

- Suck-back feature ensures accuracy and control.
- Dispenses products up to 15,000 cP with ¼ in. feed line (standard).
- Dispenses products up to 80,000 cP with ⅜ in. feed line (optional).
- Operational with manual, semiautomatic and automatic controllers.

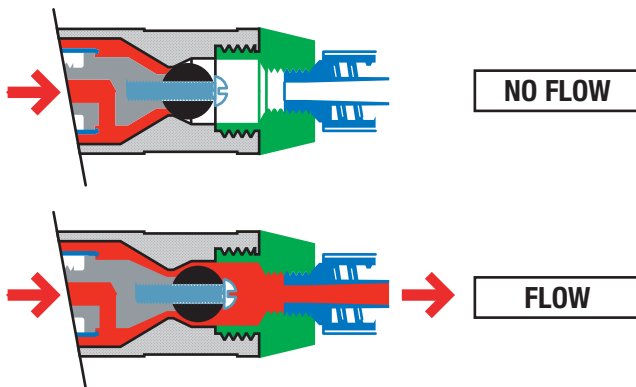

The **RED** represents the fluid path.

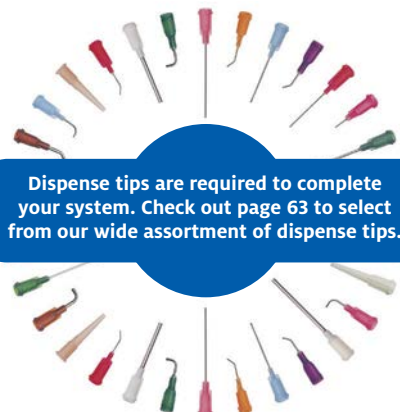





Dispense tips are required to complete your system. Check out page 63 to select from our wide assortment of dispense tips.

TECHNICAL SPECIFICATIONS

Type	Pneumatic	
Viscosity Range	Low to Medium	
Size	1.12" D x 5.2" L x 2.74" W	
Weight	97112: 4.9 oz. (138.9 g)	97116: 12 oz. (340 g)
Air Input	60 psi min.	
Product Inlet	¼"	
Wetted Components	Acetal Copolymer, PTFE, PTFE Coated Metal	
Dispense Patterns	Drop, Dot, Bead	
Used to Dispense	Light Cure Acrylics, Retaining Compounds, Threadlockers	
Stroke Adjustment	No	
Actuation	97112: Foot (Foot switch is not included with valve, but is included with all controllers.)	97116: Finger (Finger switch is included.)
Parts Included	(1) Handheld Applicator (1) Needle Kit	(1) Applicator Grip (1) Manual
Additional Information	For Spare Parts & Accessories, see page 69. For Fluid Compatibility Selector Chart, see page 46. For Dispense Tips, see pages 63-64.	

Additional Accessories Sold Separately

 98090 – LOCTITE® Shot Miser™ Reservoir	 98501 – LOCTITE® Applicator Holder	 97101 – LOCTITE® Digital Dispense Controller
 1174337 – LOCTITE® Micro Dispense Scale	 1390321 / 1390322 – LOCTITE® Integrated Semiautomatic Controllers with Low Level Sensor	 982720 / 982723 / 982726 / 982727 – LOCTITE® Bond-A-Matic® Reservoirs

PINCH TUBE APPLICATOR

LOCTITE® VARI-DROP™ APPLICATOR

Item Numbers: 97131 and 97132

Our lowest cost, handheld dispensing valve utilizing an effective pinch tube design, which can easily be exchanged out in a matter of minutes.

Features:

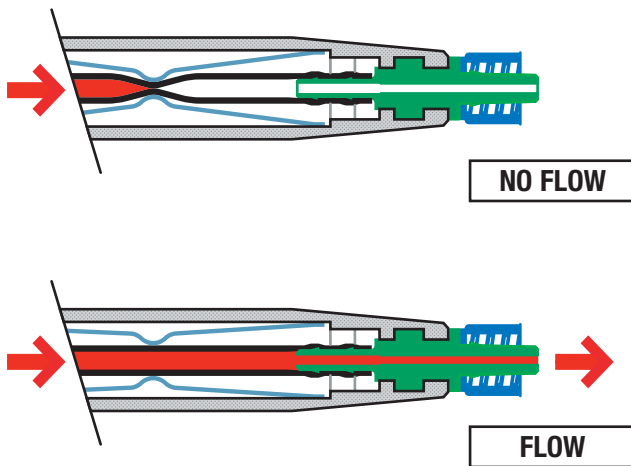

- The adjusting screw allows repeatable dispense from drops to heavy beads.
- Accepts a variety of dispensing needles to apply precise amounts of product.
- Low cost.
- Designed with light-blocking materials for light curing adhesives.
- Field serviceable.



The **RED** represents the fluid path.



Dispense tips are required to complete your system. Check out page 63 to select from our wide assortment of dispense tips.

TECHNICAL SPECIFICATIONS		
Type	Pinch Tube	
Viscosity Range	Low to Medium	
Size	5/8" H x 5/8" W x 6 1/4" L	
Weight	1.5 oz. (42.5 g)	
Air Input	100 psi	
Fluid Inlet	1/4" Tube	
Fluid Pressure	100 psi maximum	
Fluid Viscosity Range	100 to 80,000 cP	
Wetted Components	PTFE, Polyethylene	
Tubing with PTFE	97131: Yes 97132: No	
Used to Dispense	Instant Adhesives, Light Cure Acrylics, Retaining Compounds, Threadlockers	
Stroke Adjustment	No	
Actuation	Finger	
Parts Included	97131: (1) Vari-Drop™ Applicator (1) 7' x 1/4" OD PTFE-Lined Hose with Hose Guards (1) Needle Kit 97262 (1) Manual 97132: (1) Vari-Drop™ Applicator (1) Manual	
Additional Information	For Spare Parts & Accessories, see page 69. For Fluid Compatibility Selector Chart, see page 46. For Dispense Tips, see pages 63-64.	
Additional Accessories Sold Separately		
 98501 – LOCTITE® Applicator Holder	 982719 / 982722 – LOCTITE® Bond-A-Matic® 3000 Dispensers	97220 – 3/8" Feed Line Kit

LOCTITE® BRAND HANDHELD DISPENSING VALVE FLUID COMPATIBILITY CHART





PRODUCT	LOCTITE® LV Handheld Applicator	LOCTITE® Manual Handheld Applicator	LOCTITE® Pneumatic Handheld Applicator	LOCTITE® Pneumatic Handheld Applicator	LOCTITE® Vari-Drop™ Applicator
Item Number	97130	97111	97112	97116	97131 / 97132
Accelerators	✓	✓	✓	✓	✓
Acrylics		✓	✓	✓	✓
Activators	✓	✓	✓	✓	✓
Anaerobics	✓	✓	✓	✓	✓
Cyanoacrylates	✓				✓
Inks	✓	✓	✓	✓	✓
Oils		✓	✓	✓	✓
Paints		✓	✓	✓	✓
Primers	✓	✓	✓	✓	✓
Reagents	✓	✓	✓	✓	✓
Solvents	✓				✓
UV & Light Cure Fluids		✓	✓	✓	✓
UV Anaerobics		✓	✓	✓	✓
Water	✓				

Dispensing Valves

LOCTITE® brand dispensing valves are value-added, robust, dispensing valves for adhesive or fluid delivery. Each valve is uniquely designed to meet different manufacturing needs. These valves should be combined with a reservoir and/or a controller based on the chemistry and viscosity of the fluid being used and your specific process requirements.



PRODUCT	Item Number	Type	Viscosity Range	Dispense Patterns	Used to Dispense	Stroke Adjustment	Suck-Back
HIGH PRECISION VALVES							
	97113	High Precision	Low to Medium	Drop, Dot, Bead	Gel Instant Adhesives, Instant Adhesives, Retaining Compounds, Threadlockers	Yes	Yes
	97114						
	98084	High Precision	Low to Medium	Drop, Dot, Bead, Microdots	Light Cure Acrylics	Yes	No
HIGH PERFORMANCE DIAPHRAGM VALVES							
	1611449	High Performance Diaphragm	Low to Medium	Drop, Dot, Bead, Microdots	Instant Adhesives	Yes	No
	98009	High Performance Diaphragm	Low to Medium	Drop, Dot, Bead	Light Cure Acrylics, Retaining Compounds, Threadlockers	Yes	No
	98013	High Performance Diaphragm	Low to Medium	Drop, Dot, Bead	Instant Adhesives, Retaining Compounds, Threadlockers	Yes	No
	1730181	High Performance Diaphragm	Low to Medium	Drop, Dot, Bead	Silicones and Other Moisture Sensitive Adhesives	Yes	No
GENERAL DUTY DIAPHRAGM VALVES							
	97135	General Duty Diaphragm	0 to 2,500 cP	Drop, Dot, Bead	Light Cure Acrylics, Instant Adhesives, Retaining Compounds, Threadlockers	No	No
	97136		2,500 to 5,000 cP				
SPRAY VALVES							
	98520	Spray Valve	Low	Spray	Primers, Activators, Accelerators	Yes	No
JETTING VALVES							
	1850212	Jet Valve	1 to 400,000 cP	Drop, Dot, Bead	Light Cure Acrylates, Activators, Primers	No	No
HIGH VISCOSITY FLUID AND PASTE VALVES							
	986300	High Viscosity Fluid and Paste Valves	Medium to High	Drop, Bead	Anaerobic Gasketing, Retaining Compounds, Threadlockers	Yes	Yes
	1838885		10,000 -1,000,000 cP		Silicones, MS Polymers, Urethanes		Yes
	1153502		500,000 -2,000,000 cP		No		

HIGH PRECISION VALVES

LOCTITE® STATIONARY APPLICATOR VALVE

Item Numbers: 97113 and 97114

Our best pressure-time dispense valve with double-acting air to open/close for your most stringent, high volume dispensing applications.

Features:

- Slim, lightweight, patented seal-less dispense valve.
- Modular design of product shutoff valve and valve actuator provides on-line serviceability.
- Fail-safe – spring-assisted close.
- Suck-back feature eliminates product stringing.
- Double-acting cylinder allows adjustable opening and closing speed for process control.
- Cycle rate exceeds 36 per minute.
- Operational with pressure-time applications.
- Dispenses fluids up to 15,000 cP (item 97113) or 80,000 cP (item 97114).



Handheld Option

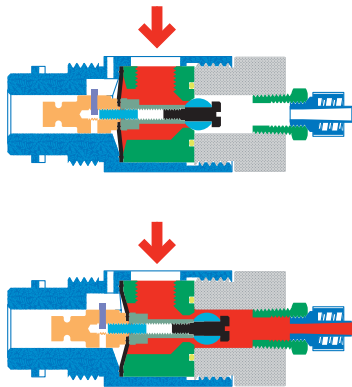

NO FLOW











The RED represents the fluid path.

FLOW

TECHNICAL SPECIFICATIONS

Type	High Precision	
Viscosity Range	Low to Medium	
Size	7.6" L x 2.4" H	
Weight	0.75 lbs.	
Maximum Fluid Pressure	80 psi	
Air Inlet Port	½" Tubing Fitting	
Air Inlet	60 to 80 psi/minute	
Product Inlet	97113: ¼" OD Tube	97114: ⅜" OD Tube
Fluid Outlet	¼" UNF, Tip Adapter, Luer-Lok Output Fitting	
Dispense Patterns	Drop, Dot, Bead	
Used to Dispense	Gel Instant Adhesives, Instant Adhesives, Retaining Compounds, Threadlockers	
Stroke Adjustment	Yes	
Suck-Back	Yes	
Valve Type	Pressure-Time Dispense	
Wetted Components	Acetal Copolymer, PTFE and PTFE Coated Metals	
Air Cylinder	Double-acting diaphragm cylinder / flow control of both ports / spring return for fail-safe function	
Parts Included	(1) Feed Line (1) Dispense Valve	(1) Anti-Bubbler Adapter and Sleeve (1) Needle Kit (1) Manual
Additional Information	For Spare Parts & Accessories, see page 69. For Fluid Compatibility Selector Chart, see pages 57-58. For Dispense Tips, see pages 63-64.	

Additional Accessories Sold Separately

 97152 – LOCTITE® Dual-Channel Automatic Controller	 1390321 / 1390322 – LOCTITE® Integrated Semiautomatic Controllers with Low Level Sensors	 982726 / 982727 – LOCTITE® Bond-A-Matic® Reservoirs
 97101 – LOCTITE® Digital Dispense Controller		 982720 / 982723 – LOCTITE® Bond-A-Matic® Reservoirs with Low Level Sensors
 1022006 – LOCTITE® Digital Multi-Functional Controller		 98022 – LOCTITE® 300 ml Cartridge Pusher
 1095801 – LOCTITE® External Mix Assembly, designed for positioning two (2) separate dispense valves (sold separately) in proper alignment for high-speed dispensing of a 2-part, externally mixed adhesive without the use of a static mix nozzle.		
 1176444 – Pistol Grip Trigger (Requires mounting bracket 97242 for use with 97113 / 97114)		 1174337 – LOCTITE® Micro Dispense Scale

HIGH PRECISION VALVES

LOCTITE® MICRO NEEDLE VALVE

Item Number: 98084

Provides precision adhesive dispensing all the way down to 0.0005 ml. No other LOCTITE® valve is that precise at such small dispense quantities.





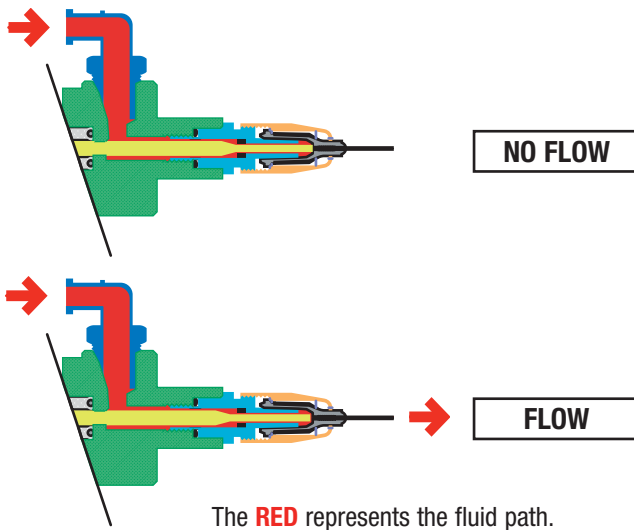

Features:

- Dispenses low- to medium-viscosity UV curing products down to a fraction of a microliter.
- Short opening stroke provides extremely fast, positive shutoff.
- External stroke control adjustment makes it easy for operator to fine-tune shot sizes.
- Compact design allows for mounting flexibility and easy integration into automated applications.
- Capable of connecting to syringe barrels as small as 5 ml to 30 ml.
- Change the Luer fitting to a tube fitting, and any size pressure reservoir can be used.
- Designed to be used with high precision stainless steel needles.



98084 – LOCTITE® Micro Needle with Handheld Option



TECHNICAL SPECIFICATIONS	
Type	High Precision
Viscosity Range	Low to Medium
Size	5" L x 1.1" D (127 mm L x 28.5 mm D)
Weight	8 oz. (227 g)
Maximum Fluid Pressure	100 psi (7 bar)
Fluid Inlet	1/8" NPT
Air Inlet	10-32 UNF-2B Male Luer-Lok
Pneumatic Supply	Minimum – 60 psi (4.8 bar) Maximum – 100 psi (7 bar)
Product Inlet	1/4" NPT
Fluid Outlet	1/4" UNF Luer-Lok Tip
Dispense Patterns	Drop, Dot, Bead
Used to Dispense	Light Cure Acrylics
Stroke Adjustment	Yes
Suck-Back	No
Valve Type	Pressure-Time Dispense
Wetted Components	Acetal Copolymer, Stainless Steel, PTFE
Parts Included	(1) Needle Variety Kit – Uses stainless steel needles only (1) Fluid Fitting, 1/8" NPT x 1/4" Tube (1) Product Feed Line, 1/4" (1) Air Line Tubing, 5 ft. (1) Micro Needle Valve (1) Manual
Additional Information	For Spare Parts & Accessories, see page 69. For Fluid Compatibility Selector Chart, see pages 57-58. For Dispense Tips, see pages 63-64.
Additional Accessories Sold Separately	
 <p>97152 – LOCTITE® Dual-Channel Automatic Controller</p>	 <p>1390321 / 1390322 – LOCTITE® Integrated Semiautomatic Controllers with Low Level Sensors</p>
 <p>1174337 – LOCTITE® Micro Dispense Scale</p>	 <p>982720 / 982723 / 982726 / 982727 – LOCTITE® Bond-A-Matic® Reservoirs</p>
 <p>1022006 – LOCTITE® Digital Multi-Functional Controller</p>	 <p>97101 – LOCTITE® Digital Dispense Controller</p>
<p>98099 – LOCTITE® Precision Filter and Regulator (required for use with all pressure-time dispense controllers, other than 97123) 985281 – LOCTITE® Bracket, 997569 – LOCTITE® Silicone Grease</p>	

LOCTITE® EQ VA10 MICRO DIAPHRAGM VALVE







Item Number: 1611449

The LOCTITE® EQ VA10 Micro Diaphragm Valve is a miniature dispensing valve designed to dispense precision drops and beads of low- to medium-viscosity adhesive. Its compact size allows for closer center-to-center spacing for multiple point dispensing in applications like needle bonding. Its lightweight feature allows for faster motion control movements when used on robot systems and can dispense at a faster frequency as compared to conventional valves. A tamper-resistant stroke control provides for high-resolution stroke adjustment .

Features:

- Stackable at 0.75" on center.
- Bubble-free, no-drip dispensing.
- Compact size and weight.
- High-resolution stroke adjustment.
- Sealless design.
- Fail-safe – air to open. Spring to close.
- UHMW polyethylene diaphragm.
- Fluid body material: 316 stainless steel
- Fitting – ¼" barbed type, 316 stainless steel
- Tamper-resistant stroke control.



TECHNICAL SPECIFICATIONS		
Type	High Precision Diaphragm	
Viscosity Range	Low to Medium	
Size	2.62" x 0.75"	
Weight	50 grams	
Maximum Fluid Pressure	70 psi	
Fluid Inlet	¼" Barbed	
Air Inlet	70 to 90 psi	
Product Inlet	¼" PTFE-Lined Tubing	
Fluid Outlet	¼"-28 UNF, Tip Adapter, Luer-Lok Output Fitting	
Dispense Patterns	Drop, Dot, Bead, Microdot	
Used to Dispense	Light Cure Adhesives, Cyanoacrylates, Primers/Activators, Silicones and Acrylics	
Stroke Adjustment	Yes	
Suck-Back	No	
Valve Type	Diaphragm	
Wetted Components	Chamber: Stainless Steel Diaphragm: Ultra-High Molecular Weight Polyethylene	
Parts Included	(1) 2 m Air Line Tubing (1) Valve Assembly (1) 2 m Product Tubing, (1) Instructional Manual ¼" OD PTFE-Lined (1) Tamper-Resistant (1) Needle Kit Stroke Key	
Additional Information	For Spare Parts & Accessories, see page 69. For Fluid Compatibility Selector Chart, see pages 57-58. For Dispense Tips, see pages 63-64.	
Additional Accessories Sold Separately		
 <p>97152 – LOCTITE® Dual-Channel Automatic Controller</p>	 <p>1390321 / 1390322 – LOCTITE® Integrated Semiautomatic Controllers with Low Level Sensors</p>	
 <p>97101 – LOCTITE® Digital Dispense Controller</p>	 <p>982726 / 982727 – LOCTITE® Bond-A-Matic® Reservoirs</p>	 <p>982720 / 982723 – LOCTITE® Bond-A-Matic® Reservoirs with Low Level Sensors</p>
 <p>1174337 – LOCTITE® Micro Dispense Scale</p>	 <p>1022006 – LOCTITE® Digital Multi-Functional Controller</p>	

HIGH PERFORMANCE DIAPHRAGM VALVES

LOCTITE® LIGHT CURE DISPENSE VALVE

Item Number: 98009

LOCTITE® CYANOACRYLATE DISPENSE VALVE

Item Number: 98013

LOCTITE® EQ VA15 DIAPHRAGM VALVE

Item Number: 1730181

With our high performance “workhorse” diaphragm valves for dispensing low-to-medium light curing (98009), cyanoacrylates (98013) or silicones and other moisture sensitive adhesives (1730181). You can expect reliable, long-term service and highly repeatable shot-to-shot performance for even your toughest high cycle rate requirements. These valves have a very small profile and simple design to facilitate quick field repairs.



Features of Dispense Valves:

- Compact size and weight.
- Adjustable fluid flow control.
- Fail-safe, air to open, spring close.
- Positive shutoff, no seals.
- Bubble-free, no-drip dispensing.
- Field serviceable.
- Easy cleaning without valve demounting.
- Cycle rate exceeds 500 per minute.

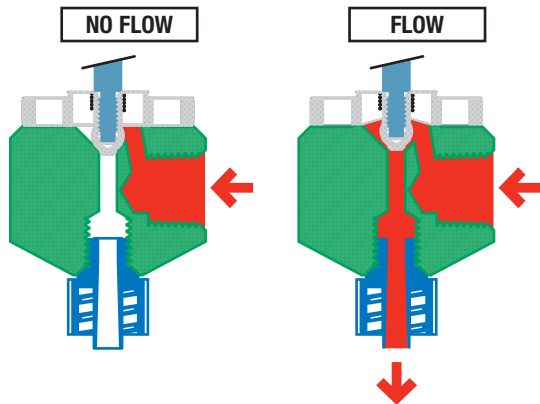

The RED represents the fluid path.

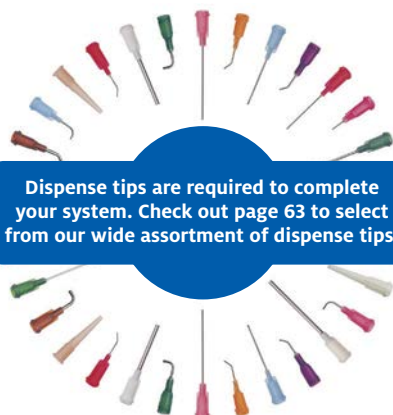

Dispense tips are required to complete your system. Check out page 63 to select from our wide assortment of dispense tips.

TECHNICAL SPECIFICATIONS

TECHNICAL SPECIFICATIONS	
Type	High Performance Diaphragm
Viscosity Range	Low to Medium
Size	3.090" x 1.060" Diameter
Weight	4.5 oz. (128 g)
Maximum Fluid Pressure	70 psi
Fluid Inlet	1/8" NPT
Fluid Outlet	1/4"-28 UNF, Tip Adapter, Luer-Lok Output Fitting
Air Inlet Port	1/4" Tube Fitting
Air Input	70 to 90 psi
Air Cylinder	Single Acting, Spring Return, Stroke Control, Aluminum, Hard Coated Finish
Dispense Patterns	Drop, Dot, Bead, Microdot
Used to Dispense	98009: Light Cure Acrylics, Retaining Compounds, Threadlockers 98013: Gel Instant Adhesives, Retaining Compounds, Threadlockers 1730181: Silicones and Other Moisture Sensitive Adhesives
Stroke Adjustment	Yes
Suck-Back	No
Valve Type	Diaphragm
Wetted Components	98009: Chamber: ACETAL Diaphragm: UHMW Irradiated Polyethylene 98013: Chamber: UHMW Polyethylene Diaphragm: UHMW Irradiated Polyethylene 1730181: Chamber: SS Diaphragm: UHMW Irradiated Polyethylene
Mounting Hole	(1) 10-32 UNF
Parts Included	(1) 5 ft. Air Line Tubing (attached to valve) (1) Needle Kit (1) 6 ft. Product Tubing, 1/4" OD, PTFE-Lined (1) Valve Mount Screw (1) Valve Assembly (1) Manual
Additional Information	For Spare Parts & Accessories, see page 69. For Fluid Compatibility Selector Chart, see pages 57-58. For Dispense Tips, see pages 63-64.

Additional Accessories Sold Separately

97152 – LOCTITE® Dual-Channel Automatic Controller	1390321 / 1390322 – LOCTITE® Integrated Semiautomatic Controllers with Low Level Sensors	97115 – LOCTITE® Electric RotorSpray
97101 – LOCTITE® Digital Dispense Controller	982726 / 982727 – LOCTITE® Bond-A-Matic® Reservoirs	982720 / 982723 – LOCTITE® Bond-A-Matic® Reservoirs with Low Level Sensors
1022006 – LOCTITE® Digital Multi-Functional Controller	98022 – LOCTITE® 300 ml Cartridge Pusher	
1176444 – Pistol Grip Trigger	1174337 – LOCTITE® Micro Dispense Scale	

For additional information and the full line of equipment, visit www.equipment.loctite.com.

GENERAL-PURPOSE DIAPHRAGM VALVES

LOCTITE® DIAPHRAGM VALVE

Item Numbers: 97135 and 97136







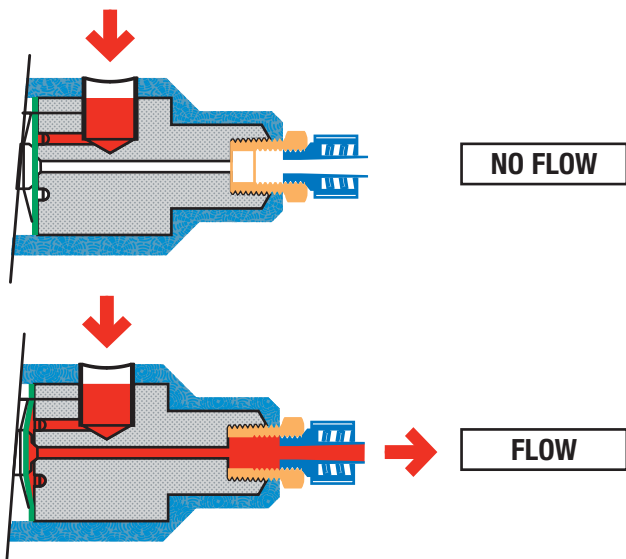

Our most economical PTFE diaphragm dispense valves that can be used to dispense lower viscosity adhesives. Perfect choice for anaerobic bore coating applications utilizing our LOCTITE® Electric RotorSpray and accessories.

Features:

- Cost-effective valve for use with pressure-time dispense systems.
- Modular design and floating diaphragm allow for easy cleaning or repair.
- Fail-safe, spring-assisted close.
- Internal components are made of PTFE to prevent premature curing.
- Flow rates can be increased with use of a 3/8 in. feed line.
- Available in low viscosity (item 97135) and medium viscosity (item 97136) versions.

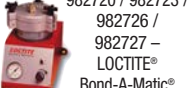

The RED represents the fluid path.

TECHNICAL SPECIFICATIONS		
Type	General Duty Diaphragm	
Viscosity Range	0 to 2,500 cP	2,500 to 5,000 cP
Size	5" L x 1.25" D (127 mm L x 32 mm D)	
Weight	10.5 oz. (300 g)	
Maximum Fluid Pressure	7 to 58 psi (0.5 to 4 bar)	
Fluid Inlet	1/4" Tubing or upgrade to 3/8" (Item 97220)	
Air Inlet	5/32" Tubing	
Pneumatic Supply	Minimum – 73 psi (5 bar)	Maximum – 100 psi (7 bar)
Product Inlet	97135: 1/4" OD	97136: 1/8" OD
Fluid Outlet	1/4" UNF Luer-Lok Tip	
Dispense Patterns	Drop, Dot, Bead	
Used to Dispense	Light Cure Acrylics, Retaining Compounds, Threadlockers	
Stroke Adjustment	No	
Suck-Back	No	
Valve Type	Pressure-Time Dispense	
Wetted Components	Acetal, Stainless Steel, PTFE-Coated Metals	
Parts Included	(1) Diaphragm Valve	(1) Product Feed Line, 1/4"
	(1) Needle Variety Kit	(1) Manual
Additional Information	For Spare Parts & Accessories, see page 69. For Fluid Compatibility Selector Chart, see pages 57-58. For Dispense Tips, see pages 63-64.	
Additional Accessories Sold Separately		
 98090 – LOCTITE® Shot Miser™ Reservoir	 97152 – LOCTITE® Dual-Channel Automatic Controller	 1022006 – LOCTITE® Digital Multi-Functional Controller
 97101 – LOCTITE® Digital Dispense Controller	 1390321 / 1390322 – LOCTITE® Integrated Semiautomatic Controllers with Low Level Sensors	 982720 / 982723 / 982726 / 982727 – LOCTITE® Bond-A-Matic® Reservoirs
97115 – LOCTITE® Electric RotorSpray		
97119 – LOCTITE® Advancing Slides		
I.D. Bore Coat Accessories		
 97152	 97115	 97119

SPRAY VALVES

LOCTITE® SPRAY VALVE

Item Number: 98520

LOCTITE® SPRAY VALVE CONTROLLER

Item Number: 1406023

The LOCTITE® Spray Valve and LOCTITE® Spray Valve Controller provide an effective solution for automatic spraying of low viscosity primers, accelerators and activators up to 1,200 cP with high precision and long-term reliability. You can count on consistent performance over a wide range of operating conditions, giving you spray coverage consistency shot after shot.

Features:

LOCTITE® Spray Valve

- High precision, short stroke, needle and seat design provide repeatable spray pattern performance.
- Air pressure and stroke adjustment allow a wide range of spray pattern coverage control.
- Full stainless steel body and wetted parts provide long-term performance and durability.
- Cycle rate up to 600 per minute.
- Easy cleaning and servicing.
- A 0.046 in. nozzle diameter (standard) provides consistent round, full-cone pattern.
- Optional 0.014 in. and 0.028 in. diameter nozzle kits for lower spray pattern applications.

LOCTITE® Spray Valve Controller

- Microprocessor-based, timed controller.
- Fully independent valve, open/close and atomization air supply.
- Three separate timed sequences – pre-spray, valve on, post-spray/valve off.
- Timed or manual mode with foot pedal control.
- All time modes maintained in memory with AC power disconnected.

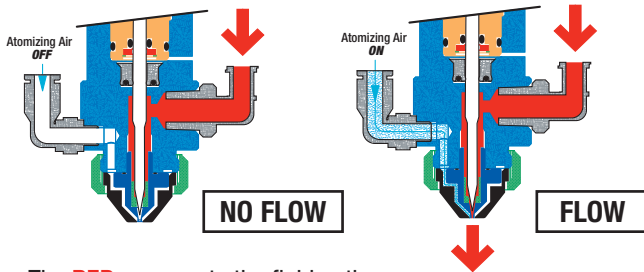

The **RED** represents the fluid path.



98520 – LOCTITE® Spray Valve with Handheld Option



1406023 – LOCTITE® Spray Valve Controller (See page 17)

TECHNICAL SPECIFICATIONS		
98520 – LOCTITE® Spray Valve		
Type	Spray Valve	
Viscosity Range	Up to 1,200 cP	
Air Pressure Supply	60 to 100 psi	
Fluid Inlet Port	1/8" NPT	
Weight	0.8 lbs. (385 g)	
Spray Height / Pattern Diameter	1"/0.25", 2"/0.50", 3"/0.75", 4"/1.5", 5"/3" (0.046 nozzle)	
Dispense Pattern	Spray – Circular	
Used to Dispense	Accelerators, Activators, Primers	
Stroke Adjustment	Yes	
Suck-Back	No	
Valve Type	Pressure-Time Dispense	
Wetted Components	304 Stainless Steel	
Parts Included	(1) Valve Mounting Bracket with screw (1) Valve Assembly (1) Fluid Line Assembly (1) Air Line Assembly (1) Operation Manual (1) Hex Key (1) Seat Removal Tool	
1406023 – LOCTITE® Spray Valve Controller		
Power Source	120 VAC	
Air Supply	1/8" Tube Fitting – 100 psi maximum	
Weight	5.5 lbs.	
Dimensions	2.5" H x 12.4" L x 7.6" D	
Parts Included	(1) Controller Unit & Power Cord (1) Foot Pedal (1) Air Supply Line & Filter – 4 ft.	
Additional Information	For Spare Parts & Accessories, see page 69. For Fluid Compatibility Selector Chart, see pages 57-58.	
Additional Accessories Sold Separately		
989268 – 0.014" Nozzle Kit 989269 – 0.028" Nozzle Kit 984621 – LOCTITE® Replacement Foot Switch	982720 / 982723 – LOCTITE® Bond-A-Matic® Reservoirs with Low Level Sensors	982726 / 982727 – LOCTITE® Bond-A-Matic® Reservoirs



LOCTITE® EQ VA30 JET VALVE

Item Number: 1850212

LOCTITE® EQ VA30 JET CONTROLLER

Item Number: 1850211

The VA30 Jet Valve and Controller are designed for fluid dispensing in the electronics, industrial, semiconductor and life science markets. It is unlike any other jet on the market because this non-contact jet dispensing product employs a unique diaphragm technology. The VA30 Jet Valve is extremely fast, can dispense on-the-fly, and is designed for robotic applications. The system is suited for dispensing a wide range of fluids for a variety of applications, and to ensure best product compatibility, the fluid path is made from ceramic and stainless steel and the diaphragm is made of a highly fluorinated elastomeric material.

Features:

LOCTITE® EQ VA30 Jet Valve and Jet Controller

- No fluid seals to clean or replace.
- Valve is field repairable, not necessary to return to factory for rebuild or repair.
- Integral heater with minimal fluid heated.
- Tungsten carbide or ceramic internal components for long life.
- Can apply multiple drops-per-location at a speed up to 300 drops/sec.
- Hard to dispense fluids can be dispensed reliably in volumes as small as 10 nanoliters.
- The drops can be dispensed into areas with clearance as small as 300µm without contamination of the surface.
- User can adjust drop size ± 20% from normal size allowing a wide range of adjustability.

EQ VA30 JET CONTROLLER:

Item Number: 1850211

- (1) EQ VA30 Jet Controller
- (1) Power Cable
- (1) Valve Connection Cable (15 pin Sub-D)
- (1) Robot Connection Cable (26 pin Sub-D)
- (1) 2 m Air Connection Tube 6mm Diameter
- (1) Operating Manual



EQ VA30 JET VALVE:

Item Number: 1850212

- (1) EQ VA30 Jet Valve
- (1) Diaphragm (FFKM black)
- (5) O-Rings
- (1) Syringe Air Connector for 30 or 50 cc
- (1) 1.5 m Air Connection Tube 6mm Diameter
- (5) Feed Tubes (black)
- (1) Adapter Ring for 10 cc Syringes



Nozzle Type (Order Separately):

- 75µm Nozzle Plate Item Number: 1872279 or
- 125µm Nozzle Plate 1871880 or
- 200µm Nozzle Plate 1871874

Spare Parts and Accessories

- Diaphragm FFKM (5 pack) 1871875
- O-Ring (10 pack) 1872538
- Feed Tubes Black (50 pack) 1871876
- Cleaning Kit for 75µm Nozzle 1871879
- Syringe Air Line Adapter (2 pack) 88678
- Cleaning Kit for 125µm Nozzle 1871878
- Cleaning Kit for 200µm Nozzle 1871877
- Air Cylinder Repair Kit 1874364
- Heater Repair Kit 1874363

TECHNICAL SPECIFICATIONS	
1850211 – LOCTITE® EQ VA30 Jet Valve Controller	
PARAMETER	SPECIFICATIONS
Size EQ VA30 Jet Valve w/o mounting bracket)	Dimensions: 152.5 mm H x 24.5 mm W x 341.4 mm D Weight: 3200 grams
Power	100-240 Vac, 50/60 Hz, 50 Watts maximum, single phase Fuse: 5 x 20 mm, Quick-Acting, 1 amp, 250 VAC
Input Air Pressure	<ul style="list-style-type: none"> • Source: 70 to 100 psi • Clean, dry air required • 40µm filter required • External pressure release device recommended 100 psi
Output Air Pressure	Jet: 35 psi to 90 psi Fluid: 40 psi Max
Nozzle Heater	<ul style="list-style-type: none"> • Heating, Room Temperature to 70°C Max <ul style="list-style-type: none"> • + or - 1.0°C @ 50°C • PID Control Using Platinum RTD • 24VDC, 5.7W, 100 ohm
Ambient Temperature	15°C to 50°C
Controller Interface	<ul style="list-style-type: none"> • LCD Display with Keypad • RS-232 Serial Port
Input/Output	26 pin DB Connector, Digital Inputs Pulled to GND
EQ VA30 Jet Valve Controller Software	Windows XP®, Windows Vista® and Windows® 7 or 8, Fluid Tables with Parameters, Programmable Drop Recipes
Ingress Protection	IP20 / TYPE 1 Protected against ingress of solid foreign objects greater than 12.5 mm. Not protected for ingress of water. Enclosure constructed for indoor use.
Altitude	2000 meters maximum (6652 ft)
System Integration	Designed for Robotic Applications

TECHNICAL SPECIFICATIONS	
1850212 – LOCTITE® EQ VA30 Jet Valve	
PARAMETER	SPECIFICATIONS
Size EQ VA30 Jet Valve w/o mounting bracket)	Dimensions: 90.3 mm H x 25.4 mm W x 82.0 mm D Weight: 400 grams
Drop Size Range 75 µm Nozzle 125 µm Nozzle 200 µm Nozzle	Typical, depends on material 5-25 µgrams 25-80 µgrams 80-200 µgrams
Speed: Refill Time: Dwell Time:	> 1.7 msec > 1.9 msec
Fluid Viscosity Range	1-400K mPas (cps)
Fluid Syringes	10, 30 and 55 cc
Input Air Pressure	Jet: 35 psi to 90 psi Fluid: 40 psi Max
Nozzle Heater	Heating, Room Temperature to 70°C Max + or - 1.0°C @ 50°C PID Control Using Platinum RTD 24VDC, 5.7W, 100 ohm
Ambient Temperature	15°C to 50°C

HIGH VISCOSITY FLUID AND PASTE VALVES

LOCTITE® POPPET VALVE

Item Number: 986300

Double-acting dispense valve that is used to dispense medium- to high-viscosity anaerobic gasketing products and structural acrylics. It features a suck-back capability and can operate at fluid pressures up to 650 psi. Delrin® valve body is normally used in conjunction with a Pump-A-Bead™ II 850 ml Dispenser System.

Features:

- Poppet design gives valve “suck-back” feature.
- Bayonet-type mounting of nozzles provides end location repeatability.
- Handles product pressures up to 625 psi.
- Positive mounting surface.
- High strength plastic material versions are specially treated to be inert to LOCTITE® brand products.



NO FLOW

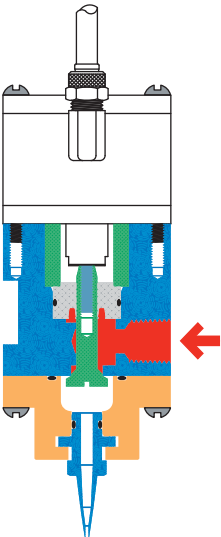

FLOW

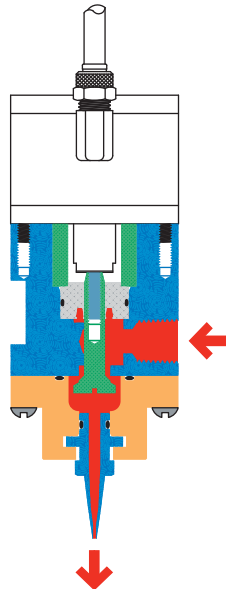

TECHNICAL SPECIFICATIONS

Type	High Viscosity Fluids and Pastes
Viscosity Range	Medium to High Anaerobics and Acrylics
Size	5.28" H x 2.00" D
Weight	1.3 lb. (0.59 kg) valve plus fittings and tubing
Maximum Fluid Pressure	Should not exceed 625 psi
Air Input	60 psi
Inlet	¼" NPT
Dispense Tip Style	986300: Bayonet Style
Used to Dispense	Anaerobic Gasketing, Retaining Compounds, Threadlockers
Dispense Patterns	Bead, Drop
Stroke Adjustment	Yes
Suck-Back	Yes
Valve Type	Pressure-Time Dispense
Wetted Components	Acetal Copolymer treated with a proprietary LOCTITE® brand process
Parts Included	(1) Acetal Copolymer Body (2) 4 ft. Control Air Tubing (1) 4 ft. Product Supply Tubing (1) Accessory Kit (1) Manual
Additional Information	For Spare Parts & Bayonet-type Nozzles, see page 69. For Fluid Compatibility Selector Chart, see pages 57-58. For Luer-Lok Dispense Tips, see pages 63-64.
Additional Accessories Sold Separately	
 986000 – LOCTITE® Pump-A-Bead™ II	

HIGH VISCOSITY FLUID AND PASTE VALVES

LOCTITE® EQ VA25 DISPENSE VALVE – 50 BAR

Item Number: 1838885

The perfect dispensing valve to complement our LOCTITE® Benchtop High Pressure Dispenser for 300 ml cartridges. High precision, double-acting dispense valve that is used to dispense medium- to high-viscosity silicones, MS polymers and urethane products.

Features:

- Lightweight and durable – can be mounted or comfortably handheld.
- Handles high viscosity adhesives up to 1,000,00 cP.
- Bubble-free, no-drip dispensing with suck-back control.
- High-resolution stroke adjustment.
- Double-acting – air to open/air to close for precision dispensing.

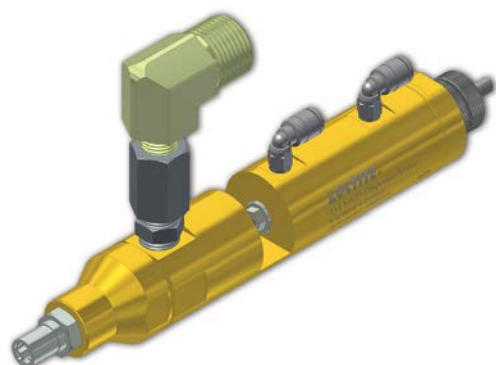

LOCTITE® HIGH PRESSURE DISPENSE VALVE – 150 BAR

Item Number: 1153502

Our top-of-the-line high pressure stainless steel dispense valve with double-acting valve actuation. It also can be used with our LOCTITE® Benchtop High Pressure Dispenser or with pail and drum pump applications, sold as part of our Special Products Line.

Features:

- Stainless steel valve ensures long-term, durable dispensing performance.
- Working fluid pressure up to 2,175 psi to accommodate high viscosity adhesives.
- Bubble-free, no-drip dispensing with positive needle valve shutoff.
- High resolution stroke adjustment.
- Double-acting open/close valve provides high level of dispensing precision.



TECHNICAL SPECIFICATIONS	
Type	High Viscosity Fluids and Pastes
Viscosity Range	10,000 to 1,000,000 cP
Pneumatic Supply	100 psi maximum
Pneumatic Air Quality	Filtered 10 micron, oil-free, non-condensing (Optional, use LOCTITE® Air Filter - Regulator 985397)
Dimensions	8.3" L x 1.22" D (200 mm x 31 mm)
Free-Flow Orifice	0.200" Diameter (5 mm)
Inlet Thread	½" – 14" BSPP with JIS 60" Core
Outlet Thread	Luer-Lok
Maximum Fluid Pressure	725 psi
Weight	1.2 lbs.
Stroke Adjustment	Yes
Suck-Back	Yes
Wetted Components	Aluminum
Parts Included	(1) High Pressure Valve (1) 2 M Air Line Tubing (1) Manual
Additional Information	For Fluid Compatibility Selector Chart, see pages 57-58. For Luer-Lok Dispense Tips, see pages 63-64.
Additional Accessories Sold Separately	
 <p>1046901 – LOCTITE® High Pressure 300 ml Benchtop Cartridge Dispenser</p>	

TECHNICAL SPECIFICATIONS	
Type	High Viscosity Fluids and Pastes
Viscosity Range	Approximately 500,000 to 2,000,000 cP
Pneumatic Supply	55 psi to 85 psi
Pneumatic Air Quality	Filtered 10 micron, oil-free, non-condensing (Optional, use LOCTITE® Air Filter - Regulator 985397)
Dimensions	6.220" L x 1.181" W x 1.181" H
Free-Flow Orifice	0.118" Diameter (3 mm)
Inlet Thread	¼" NPT Female
Outlet Thread	Luer-Lok
Max Fluid Pressure	2175 psi (150 bar)
Weight	1.5 lbs.
Stroke Adjustment	Yes
Suck-Back	No
Wetted Components	Stainless Steel
Parts Included	(1) High Pressure Valve (1) 2 M Air Line Tubing (1) Manual
Additional Information	For Fluid Compatibility Selector Chart, see pages 57-58. For Luer-Lok Dispense Tips, see pages 63-64.
Additional Accessories Sold Separately	
 <p>1046901 – LOCTITE® High Pressure 300 ml Benchtop Cartridge Dispenser</p>	

LOCTITE® BRAND VALVE & PUMP FLUID COMPATIBILITY CHART



PRODUCT	LOCTITE® EQ VA10 Micro Diaphragm Valve	LOCTITE® Light Cure Dispense Valve	LOCTITE® Cyanoacrylate Dispense Valve	LOCTITE® EQ VA15 Diaphragm Valve	LOCTITE® Micro Needle Valve
Item Numbers	1611449	98009	98013	1730181	98084
Accelerators	✓	✓	✓	✓	
Acrylics	✓	✓		✓	✓
Activators	✓	✓	✓	✓	
Anaerobics		✓	✓		
Anaerobic Gasketing					
Cyanoacrylates	✓		✓	✓	
Inks	✓	✓	✓	✓	✓
Lubricants	✓			✓	
Modified Silanes					
Nonabrasive Greases	✓			✓	
Oils	✓	✓	✓	✓	
One-Part Epoxies	✓			✓	
Paints	✓	✓	✓	✓	
Primers	✓	✓	✓	✓	
Reagents		✓	✓	✓	
Silicones	✓			✓	
Solvents	✓	✓	✓	✓	
UV & Light Cure Fluids	✓	✓		✓	✓
UV Anaerobics		✓			
Water	✓	✓	✓	✓	✓

LOCTITE® BRAND VALVE & PUMP FLUID COMPATIBILITY CHART (CONTINUED)



PRODUCT	LOCTITE® Diaphragm Valve	LOCTITE® Stationary Applicator Valve	LOCTITE® Spray Valve	LOCTITE® Poppet Valve	LOCTITE® EQ VA25 Dispense Valve – 50 Bar	LOCTITE® High Pressure Dispense Valve – 150 Bar
Item Numbers	97135 / 97136	97113 / 97114	98520	986300	1838885	1153502
Accelerators			✓			
Acrylics	✓	✓		✓		
Activators			✓			
Anaerobics	✓	✓		✓		
Anaerobic Gasketing				✓		
Cyanoacrylates	✓	✓				
Inks	✓	✓	✓			
Lubricants		✓	✓	✓	✓	✓
Modified Silanes					✓	✓
Nonabrasive Greases				✓		✓
Oils	✓	✓			✓	
One-Part Epoxies		✓		✓		✓
Paints		✓	✓			
Primers			✓			
Reagents			✓			
Silicones					✓	✓
Solvents			✓			
UV & Light Cure Fluids	✓	✓				
UV Anaerobics	✓	✓				
Water	✓		✓			

Anaerobic – Special Dispense Systems

LOCTITE® brand anaerobic dispense systems are designed to apply LOCTITE® anaerobic products for threadlocking, retaining and sealing in a wide range of applications from I.D. bore coating to gasket making.

LOCTITE® POSITIVE DISPLACEMENT PUMP

Item Number: 983330

The LOCTITE® Positive Displacement Pump features a seal-less design. It is specifically designed to dispense LOCTITE® brand threadlockers and retaining compounds in LOCTITE® Rotospray™ applications with a high degree of precision. The dispense capability of this pump is 0.02 cc to 0.4 cc. It has a modular design for easy maintenance. For LOCTITE® Rotospray™ applications, it is normally used with the LOCTITE® Digital Multi-Function Controller (item 1022006).



Features:

- Positive displacement.
- Pneumatically operated.
- Designed for compatibility with LOCTITE® brand Rotospray™ workstations.
- Modular design of product shutoff valve and valve actuator provides on-line serviceability.
- Cycle rate for low viscosity products exceeds 120 per minute.
- Small, easy-to-use design.
- Adjustable stroke to control the amount of material dispensed.
- Compatible with a wide range of fluids.
- Repeatable and consistent delivery of product.



LOCTITE® ROTOSPRAY™ 9000 APPLICATOR

The LOCTITE® Rotospray™ 9000 Applicator is a pneumatically powered applicator used for applying 360-degree beads of a fluid on the inside diameter of any surface or threaded hole. Common materials applied are retaining compounds, threadlockers, activators/primers and oils. Common applications are engine cup plug sealing, bearing retaining and motor magnet bonding. LOCTITE® Rotospray™ applicators can be used in a variety of applications and configurations, and are typically used in conjunction with the LOCTITE® Positive Displacement Pump (item 983330) and LOCTITE® 4 Liter Gravity Feed Reservoir (item 982880). If you have an application requiring an internal 360-degree bead, contact the Henkel technical information department at **1.800.LOCTITE** (562.8483), for the right LOCTITE® Rotospray™ applicator for your application.

TECHNICAL SPECIFICATIONS	
Type	Positive Displacement Pump
Viscosity Range	Low to Medium
Size	9.15" H x 1.88" D (maximum) / 2.6" W (with connections)
Weight	1.7 lbs.
Air Input	60 to 90 psi
Product Line Feed	3/8" OD before pump, 1/4" OD after pump
Fluid Capacity	0.02 cc to 0.40 cc per shot
Cycle Speed	2 cycles per second maximum (adjustable)
Dispense Patterns	Drop
Used to Dispense	Retaining Compounds, Threadlockers, Any single-component, non-moisture-curing, low- to medium-viscosity fluid (<100,000 cP)
Stroke Adjustment	Yes
Suck-Back	No
Valve Type	Positive Displacement
Wetted Components	Acetal Copolymer, Stainless Steel and PTFE Coated Metals
Parts Included	(1) Positive Displacement Pump (1) Feed Line Accessory Kit (1) Mounting Bracket (1) Air Line Kit (1) Manual
Additional Information	For Spare Parts & Accessories, see page 69. For Fluid Compatibility Selector Chart, see pages 57-58. For Dispense Tips, see pages 63-64.
Additional Accessories Sold Separately	
 1022006 – LOCTITE® Digital Multi-Function Controller	 982880 – LOCTITE® 4 Liter Gravity Feed Reservoir
 LOCTITE® Rotospray™ 9000 Applicator	

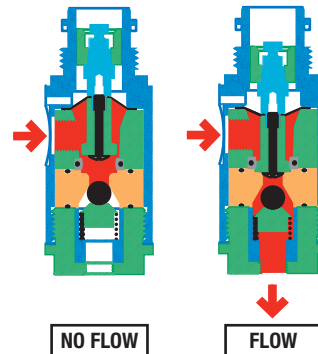

The RED represents the fluid path.

LOCTITE® PUMP-A-BEAD™ II DISPENSER

Item Number: 986000

The LOCTITE® Pump-A-Bead™ II is an all-pneumatic dispense system for pumping LOCTITE® anaerobic gasketing materials from 850 ml cartridges. A pneumatically-driven, reciprocating, positive displacement piston pump provides for consistent dispensing and ensures that air is not introduced into the product. This system is well suited for stationary or bead dispensing. The LOCTITE® Poppet Valve is also included and is ideal for dispensing continuous beads at high pressures.

Features:

- Air-driven, reciprocating, positive displacement piston pump.
- Poppet-type dispensing valve can be mounted onto a robotic arm.
- Anti-drip feature.
- Visual signal will indicate “Product Cartridge Empty.”
- Easily integrated into robotic dispensing stations.

Theory of Operation

A full cartridge of material is loaded into the system and the unit is switched to operate mode. Upon demand for dispensing, i.e., pneumatic signal, material is fed from the cartridge to an oscillating pump where the pressure is elevated to greater than 650 psi. Material is forced through a high-pressure hose to the dispense valve where it is dispensed onto the part.

TECHNICAL SPECIFICATIONS	
Air Input	All-pneumatic system, 60 to 100 psi, filtered to 40 microns
Product Viscosity	Medium to High
Compatible Materials	LOCTITE® brand deaerated anaerobic gasketing materials up to 1,000,000 cP viscosity
Pumping Rate	0.5 cc per second
Dimensions	16.3" H x 37.2" W x 9.3" D
Weight	80 lbs.
Used to Dispense	LOCTITE® brand Flange Sealants
Package Types & Sizes	850 ml cartridges
Parts Included	(1) Pump-A-Bead™ II (1) Poppet Valve Applicator (1) Manual
Additional Information	For Spare Parts & Accessories, see page 69.



THREAD SEALANT

LOCTITE® DIAL-A-SEAL® APPLICATOR

Item Number: 998400

The LOCTITE® Dial-A-Seal® Applicator is a touch actuated, all-pneumatic applicator for dispensing high viscosity LOCTITE® product onto threaded pipe fittings and nipples. The system has a quick turn turret that is equipped with cavities for 1/16, 1/8, 1/4, 3/8, 1/2, 3/4 and 1 inch male pipe threads. The unit accepts 50 ml or 250 ml tubes or 1 liter wide mouth bottles. The product dispense quantity can be adjusted with a rear adjustment knob. The upper limit per dispense cycle is 0.7 ml. It is recommended specifically for applying LOCTITE® PST® Thread Sealants, LOCTITE® Vibra-Seal®, and LOCTITE® Anti-Seize products.

Features:

- Applicator is fed directly from a 50 ml tube, 250 ml tube or 1 liter bottle.
- A quick turn turret is equipped with cavities for 1/16, 1/8, 1/4, 3/8, 1/2, 3/4 and 1 in. male pipe threads.
- Up to 0.7 ml of product can be dispensed per shot.
- Adjustable dispense volume.
- Suggested settings for each diameter fitting are preprinted on unit.

Theory of Operation

A turret head with a cavity for each size of pipe thread is attached to the output of an air actuated, positive displacement pump. The operator presses a fitting down into the correct cavity. The downward motion of the turret depresses a switch that actuates the pump. A metered amount of material is dispensed on the part.

TECHNICAL SPECIFICATIONS	
Air Input	Requires filtered (40 micron) lubricated air, 60 psi min.
Product Viscosity	Medium to High
Turret Sizes	1/16, 1/8, 1/4, 3/8, 1/2, 3/4 and 1" (NPT)
Dimensions	7.5" W x 12.2" L (Height with 50 ml tube = 14.4" / Height with 1 liter bottle = 16.7")
Used to Dispense	LOCTITE® 565™, 567™ and Vibra-Seal® Thread Sealants, and LOCTITE® brand Anti-Seize products
Package Types & Sizes	50 ml tube / 250 ml tube / 1 liter bottle
Parts Included	(1) LOCTITE® Dial-A-Seal® Applicator (2) Elbow Fittings (1) Stand for 1 Liter Bottle (1) Tube Vent (1) 1 Liter Bottle and Cap (1) Feed Tube (1) 50 ml Tube Adapter (1) Tube Adapter (1) Empty 50 ml Tube with Dispense Cap (1) Manual
Additional Information	For Spare Parts & Accessories, see page 69.



LOCTITE® HIGH PRECISION DISPENSE MONITORING SYSTEM







Item Number: 97211 (High Precision Dispense Monitor)

The LOCTITE® High Precision Dispense Monitoring System provides effective adhesive dispense monitoring. Pressure changes due to air entrapment, broken or blocked nozzles, or substrate contact can be effectively monitored by the system with a high degree of accuracy and repeatability. All out-of-tolerance dispense cycles result in error messages being displayed on the controller display.

Features: (When integrated with the LOCTITE® Dual-Channel Controller – item 97152)

Effective dispense monitoring to detect:

- Air bubbles.
- Clogged or broken dispense tips, or tip-substrate contact.
- Changes in amount of adhesive dispensed.
- Three pre-set dispense tolerances or customizable from 1 to 99%.
- PLC or PC integration to provide SPC data analysis.

TECHNICAL SPECIFICATIONS		
Power Input	24 VDC	
Power Output	1 to 10 VDC	
Dimensions	3" W x 5.5" H x 2.25" D	
Weight	0.5 lbs.	
Additional Accessories Sold Separately		
 98009 – LOCTITE® Light Cure Dispense Valve	 98013 – LOCTITE® Cyanoacrylate Dispense Valve	 97113 / 97114 – LOCTITE® Stationary Applicator Valves
 982726 / 982727 – LOCTITE® Bond-A-Matic® Reservoirs	 982720 / 982723 – LOCTITE® Bond-A-Matic® Reservoirs with Low Level Sensors	 1174337 – LOCTITE® Micro Dispense Scale

Required System Components Sold Separately	
 97152 – LOCTITE® Dual-Channel Automatic Controller	Provides dispense control and tolerance monitoring
97295 – Valve Adapter	Valve body adapter for LOCTITE® dispense valves (Item 97113 / 97114)
97200 – Valve Adapter	Valve body adapter for LOCTITE® dispense valves (Item 98009 / 98013)
8965008 – Sensor and Cable	Pressure sensor and cable for dispense valve interface
97211 – Signal Amplifier	1 required with each valve



Dispense Accessories

Henkel offers a comprehensive line of LOCTITE® brand dispense tips, static mix nozzles and syringe barrel components. High precision stainless steel, tapered polyethylene and flexible polypropylene tips all feature a positive locking, helical thread design to ensure the tip will stay intact during the toughest applications. A wide variety of static mix nozzles are available to meet your two-part adhesive dispensing needs. High-quality syringe barrels and components will ensure consistent single component adhesive dispensing needs are met.

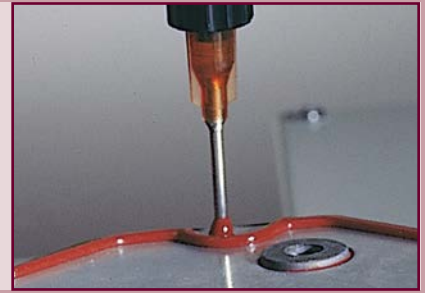

Consumables

HIGH PRECISION STAINLESS STEEL DISPENSE TIPS

¼ Inch Stainless Steel Tips Helical Thread



50 Pack Item Number	1,000 Pack Item Number	Hub Color	Gauge
830704	830703	Olive	14
98196	98197	Green	18
98198	98199	Pink	20
98200	98201	Purple	21
1585606	1585607	Blue	22
1635176	1635175	Orange	23
98624	98625	Red	25
98626	98627	Clear	27
98628	98629	Lavender	30
98114	98115	Yellow	32

½ Inch Stainless Steel Tips Helical Thread



50 Pack Item Number	1,000 Pack Item Number	Hub Color	Gauge
98163	98164	White	14
98165	98166	Amber	15
98167	98168	Green	18
98169	98170	Pink	20
98171	98172	Purple	21
98173	98174	Blue	22
98175	98176	Orange	23
98177	98178	Red	25
98179	98180	Light Grey	27

½ Inch Stainless Steel Tips Helical Thread



50 Pack Item Number	1,000 Pack Item Number	Hub Color	Gauge
1244444	—	Olive	14
98396	98397	Amber	15
98398	98399	Green	18
98400	98401	Pink	20
98424	98425	Purple	21
98402	98403	Blue	22
98611	98612	Orange	23
98404	98405	Red	25
1255059	1255058	Light Grey	27
1256848	1256497	Lavender	30

45° by ½ Inch Stainless Steel Tips Helical Thread



50 Pack Item Number	1,000 Pack Item Number	Hub Color	Gauge
98236	98237	White	14
98240	98241	Amber	15
98244	98245	Green	18
98248	98249	Pink	20
98252	98253	Purple	21
98256	98257	Blue	22
98260	98261	Orange	23
98264	98265	Red	25
98268	98269	Light Grey	27

1 Inch Stainless Steel Tips Helical Thread



50 Pack Item Number	1,000 Pack Item Number	Hub Color	Gauge
98216	98217	White	14
98218	98219	Amber	15
98220	98221	Black	16
98222	98223	Green	18
98224	98225	Pink	20
98226	98227	Purple	21
98228	98229	Blue	22
98230	98231	Orange	23
98232	98233	Red	25
98234	98235	Light Grey	27

90° by ½ Inch Stainless Steel Tips Helical Thread



50 Pack Item Number	1,000 Pack Item Number	Hub Color	Gauge
98238	98239	White	14
98242	98243	Amber	15
98246	98247	Green	18
98250	98251	Pink	20
98254	98255	Purple	21
98258	98259	Blue	22
98262	98263	Orange	23
98266	98267	Red	25
98270	98271	Light Grey	27

TAPERED DISPENSE TIPS

1/4 Inch Polyethylene Tapered Tips Helical Thread and UV Light Block Additive



50 Pack Item Number	1,000 Pack Item Number	Hub Color	Gauge
98385	98386	White	14
98387	98388	Grey	16
98389	98390	Green	18
98391	98392	Pink	20
98393	98394	Blue	22
98658*	98659*	Red	25
98660*	98661*	Clear	27

* New smaller gauge sizes.

FLEXIBLE DISPENSE TIPS

1/2 Inch Polypropylene Tips Helical Thread



50 Pack Item Number	1,000 Pack Item Number	Hub Color	Gauge
97229	98069	Amber	15
97230	98070	Green	18
97231	98071	Pink	20
97232	98082	Red	25

PRODUCT	Item Numbers	Description
	1146079 / 1146078	SS, PTFE-Lined, 25 Gauge (50/1,000 pack)
	1244443	SS, PTFE-Lined, 21 Gauge (50 pack)
	97233	Luer-Lok Adapter Kit, 20 Luer-Loks and 5 Adapters
	97248 / 98499	Tip Caps (50/1,000 pack)
	97261 / 98074	High Density Polyethylene, 15 Gauge, White (50/1,000 pack)
	97262	2 each of a variety of Helical Threaded 1/2" Stainless Steel Tips, Tapered Tips and Polypropylene Tips
	98652	Light-blocking Shield for Dispense Tips (10 pack)
	998390	Vari-Drop™ Applicator Brushes (10 pack)

CARTRIDGE ACCESSORIES

PRODUCT	Item Number	Description
	98446	Roller Assembly 1" wide band
	98448	Roller Assembly 2" wide band
	98447	Replacement Rollers 1" wide (3 pack)
	98449	Replacement Rollers 2" wide (3 pack)
	98610	3/4" wide x 3/8" NPT Dispense Nozzle (10 pack)
	1044246	Aero Nozzle for silicones in aerosol cans (10 pack)
	98128	Cartridge Dispense Tip: 1/4" male Semco Thread (10 pack)
	98371	Cartridge-Needle Adapter: (Female Luer x 1/4" male Semco Thread) Luer-Lok adapter for dispense needle attachment (5 pack)
	1147763	Cartridge-Dispense Valve Adapter Assembly Fischbach Thread x 1/4" male NPT

GENERAL-PURPOSE DISPENSE TIPS

1/2 Inch Stainless Steel Tips



50 Pack Item Number	1,000 Pack Item Number	Hub Color	Gauge
98208	98209	Olive	14
97225	98065	Amber	15
97226	98066	Green	18
97227	98067	Pink	20
98210	98211	Purple	21
98100	98080	Blue	22
98212	98213	Orange	23
97228	98068	Red	25
98214	98215	Clear	27

CHECK OUT OUR NEW AND IMPROVED GENERAL-PURPOSE DISPENSE TIPS. NOW WITH HELICAL THREADS AND SECURE PLASTIC BOX CONTAINERS.



GENERAL-PURPOSE TAPERED DISPENSE TIPS

1/4 Inch Polyethylene Tapered Tips



50 Pack Item Number	1,000 Pack Item Number	Hub Color	Gauge
98272	98273	Tan	14
97221	98061	Grey	16
97222	98062	Green	18
97223	98063	Pink	20
97224	98064	Blue	22

ADDITIONAL DISPENSE TIPS & ACCESSORIES

LOCTITE® SHOWCASE NEEDLE VARIETY KIT

Item Number: 98439



















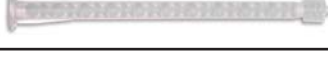

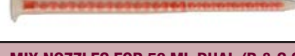

This kit contains five each of an assortment of high precision Stainless Steel Tips in various lengths and gauges. Tapered and Flexible Dispense Tips are also included. All Dispense Tips have helical thread Luer-Lok hubs for reliable locking.



CARTRIDGE ACCESSORIES

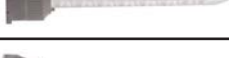

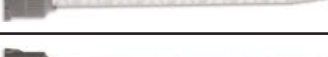
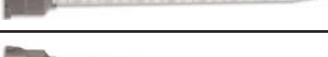









PRODUCT	Item Number	Description
	97215	Cartridge-Syringe Adapter: 1/4" Semco Thread x Female Luer, used for downloading
	98181	Cartridge-Tube Fitting Adapter: (1/4" FNPT x 1/4" male Semco Thread) used for connecting tube fittings to cartridges (984832 or 984833 also required and sold separately) (3 pack)
	984832	Tube Fitting: 1/4" male NPT x 1/4" feed tube (10 pack)
	982644	Cartridge Adapter: SS, (1/4" FNPT x 1/4" female Fischbach Thread), used for connecting tube fittings
	1045339	Cartridge-Needle Adapter: 1/4" NPT Thread x Female Luer - shown with 982644 for 1/4" Fischbach, for needle attachment (5 pack)
	1044247	Cartridge-Syringe Adapter: 1/4" MNPT x Female Luer shown with 982644 for 1/4" Fischbach, used for downloading (5 pack)

LOCTITE® BRAND STATIC MIX NOZZLES & ACCESSORIES

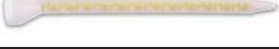

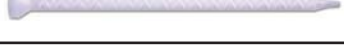
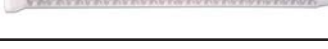



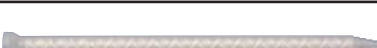
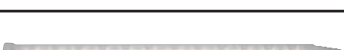



PRODUCT	Item Number	Package Quantity	Description
MIX NOZZLES FOR 50 ML DUAL (A STYLE) CARTRIDGES			
	778273 1405182	10 5,000	50 ml Square Mix Nozzle, Luer/Stepped Combo Tip, 3.25" overall length, 5.3 mm inner dimension, 16 elements; 1:1, 2:1 mix ratios.
	720227 826190	10 1,000	50 ml Square Mix Nozzle, Luer/Stepped Combo Tip, 4.5" overall length, 5.3 mm inner dimension, 24 elements; 1:1, 2:1, 4:1 mix ratios.
	98622 983509	10 2,000	50 ml Mix Nozzle, Slip-Luer, 5.9" overall length, 0.25" inner diameter, 20 elements; 1:1, 2:1 and 4:1 mix ratios. 
	98623 98364	10 2,000	50 ml Mix Nozzle, Stepped Tip-Luer, 5.9" overall length, 0.25" inner diameter, 20 elements; 1:1, 2:1 and 4:1 mix ratios. 
	720225	10	50 ml Mix Nozzle, Luer Tip, 6.0" overall length, 6.35 mm inner diameter, 21 elements; 1:1, 2:1, 4:1 mix ratios.
	720230 1116241	10 2,500	50 ml Mix Nozzle, Stepped Tip, 6.0" overall length, 6.35 mm inner diameter, 21 elements; 1:1, 2:1, 4:1 mix ratios.
	1145743 1143355	10 2,000	50 ml Mix Nozzle with Integral Needle Adapter, 5.9" overall length, 6.35 mm inner diameter, 20 elements; 1:1, 2:1 mix ratios.
	1259190	10	50 ml Round Mix Nozzle, Luer Tip, 4.7 mm inner diameter, 3.3" long, 16 elements; 1:1, 2:1 mix ratios.
	1334299	100	50 ml Mix Nozzle, Taper Tip, 3.0 mm inner diameter, 17 elements; 1:1, 2:1 – A Cartridges.
	720221 1061921	10 100	50 ml Mix Nozzle, 10:1 mix ratio, 17 elements at .213 ID, 13 elements at .157 ID, 5.87 m length
MIX NOZZLES FOR 50 ML DUAL (B & S STYLES) CARTRIDGES			
	1573156 1573154	10 1,000	50 ml Square Mix Nozzle, Taper Tip, 3.6" overall length, 5.3 mm inner dimension, 16 elements; 1:1, 2:1 mix ratios – B Cartridges.
	1573153 1573151	10 1,000	50 ml Square Mix Nozzle, Taper Tip, 4.8" overall length, 5.3 mm inner dimension, 24 elements; 1:1, 2:1 mix ratios – B Cartridges.
	1573141 1573142	10 1,000	50 ml Square Mix Nozzle, Taper Tip, 4.8" overall length, 5.3 mm inner dimension, 24 elements; 4:1, 10:1 mix ratios – B + S Cartridges.
	1197606	10	50 ml Mix Nozzle, Taper Tip, 2.4" overall length, 2.5 mm inner diameter, 16 elements; 1:1, 2:1 mix ratios – B Cartridges.
	1434516	5	50 ml CA Mix Nozzle, Taper Tip, 2.4" overall length, 2.5 mm inner diameter, 16 elements; 4:1, 10:1 mix ratios – B + S Cartridges.
	1440017	100	50 ml Mix Nozzle, Taper Tip, 3.0" overall length, 3.2 mm inner diameter, 16 elements; 1:1, 2:1 mix ratios – B Cartridges.
	1329200	100	50 ml Mix Nozzle, Taper Tip, 3.0" overall length, 3.2 mm inner diameter, 16 elements; 4:1, 10:1 mix ratio – B + S Cartridges.
	1440016	100	50 ml Mix Nozzle, Taper Tip, 3.8" overall length, 4.2 mm inner diameter, 16 elements; 1:1, 2:1 mix ratios – B Cartridges.
	1440018	100	50 ml Mix Nozzle, Taper Tip, 3.8" overall length, 4.2 mm inner diameter, 16 elements; 4:1, 10:1 mix ratios – B + S Cartridges.
	1573146 1573145	10 1,000	50 ml Mix Nozzle, Stepped Tip, 4.4" overall length, 5.4 mm inner diameter, 16 elements; 1:1, 2:1 mix ratios – B Cartridges.
	1573144 1573143	10 1,000	50 ml Mix Nozzle, Stepped Tip, 5.2" overall length, 6.5 mm inner diameter, 16 elements; 1:1, 2:1 mix ratios – B Cartridges.
	1573149 1573147	10 1,000	50 ml Mix Nozzle, Stepped Tip, 6.2" overall length, 6.5 mm inner diameter, 20 elements; 1:1, 2:1 mix ratios – B Cartridges.
	1034575	10	50 ml Mix Nozzle, Stepped Tip, 6.2" Overall Length, 6.5 mm inner diameter, 20 elements; 4:1, 10:1 mix ratio – B & S Cartridges.

For additional information and the full line of equipment, visit www.equipment.loctite.com.









LOCTITE® BRAND STATIC MIX NOZZLES & ACCESSORIES (CONTINUED)

PRODUCT	Item Number	Package Quantity	Description
MIX NOZZLES FOR 200 ML & 400 ML DUAL (C STYLE) CARTRIDGES			
	606052 804261	10 1,500	200/400 ml Square Mix Nozzle, Luer/Stepped Combo Tip, 5.0" overall length, 5.3 mm inner dimension, 24 elements; 1:1, 2:1, 4:1 mix ratios.
	720226 848088	10 1,000	200/400 ml Square Mix Nozzle, Stepped Tip, 5.1" overall length, 7.5 mm inner dimension, 24 elements; 1:1, 2:1 mix ratios.
	874905 875472	10 650	200/400 ml Square Mix Nozzle, Threaded Bell End, 114.5 mm inner dimension, 187 mm overall length, 24 elements; 1:1, 2:1 mix ratios.
	720173 1053262	10 2,000	200/400 ml Mix Nozzle, Stepped Tip, 7.3" overall length, 6.3 mm inner diameter, 24 elements; 1:1, 2:1 mix ratios.
	720174 720222	10 1,500	200/400 ml Mix Nozzle, Stepped Tip, 8.8" overall length, 8 mm inner diameter, 24 elements; 1:1, 2:1 mix ratios.
	720177 930705	10 1,000	200/400 ml Mix Nozzle, Stepped Tip, 10.9" overall length, 10 mm inner diameter, 24 elements; 1:1, 2:1 mix ratios.
	773794	50	200/400 ml Mix Nozzle, Stepped Tip, 7.4" overall length, 0.188" inner diameter, 32 elements; 1:1, 2:1 and 4:1 mix ratios.
	989518	10	200/400 ml Mix Nozzle, Stepped Tip, 9.0" overall length, 0.188" inner diameter, 48 elements; 1:1, 2:1 and 4:1 mix ratios.
	918088	10	200/400 ml Mix Nozzle, Luer Tip, Slip Luer, 9.5" overall length, 0.25" inner diameter, 32 elements; 1:1 and 2:1 mix ratios.
	1032026 1098256	10 1,200	200/400 ml Mix Nozzle, Stepped Tip, 11.3" overall length, 8 mm inner diameter, 32 elements; 1:1, 2:1 mix ratios.
	98672 98430	10 500	200/400 ml Mix Nozzle, Stepped Tip, 14.2" overall length, 9.3 mm inner diameter, 40 elements; 1:1, 2:1 mix ratios.
	98367	1,000	200/400 ml Mix Nozzle, Snap Tip, 9.3" overall length, 9.3 mm inner diameter, 24 elements; 1:1, 2:1 mix ratios.
	1228790	1,000	200/400 ml Mix Nozzle, Stepped Tip, 8.5" overall length, 13 mm inner diameter, 18 elements; 1:1, 2:1 mix ratios.
	243335	6	200/400 ml Mix Nozzle, Stepped Tip, 9.1" overall length, 13 mm inner diameter, 18 elements; 1:1, 2:1 mix ratios - Rapid Rubber.
	1065306	500	200/400 ml Mix Nozzle, Stepped Tip, 11.2" overall length, 9.3 mm inner diameter, 30 elements; 1:1, 2:1 mix ratios.
	1065313	500	200/400 ml Mix Nozzle, Stepped Tip, 11.6" overall length, 16.8 mm inner diameter, 24 elements; 1:1, 2:1 mix ratios.

LOCTITE® BRAND STATIC MIX NOZZLES & ACCESSORIES (CONTINUED)

PRODUCT	Item Number	Package Quantity	Description
MIX NOZZLES FOR 200 ML & 400 ML DUAL (F STYLE) CARTRIDGES			
	1573130 1573139	10 1,000	200/400 ml Square Mix Nozzle, Taper Tip, 5.2" overall length, 5.3 mm inner dimension, 24 elements; 1:1, 2:1 mix ratios – F Cartridges.
	1573133 1573140	10 1,000	200/400 ml Square Mix Nozzle, Stepped Tip, 5.4" overall length, 7 mm inner dimension, 24 elements; 1:1, 2:1 mix ratios – F Cartridges.
	1573132 1573134	10 1,000	200/400 ml Square Mix Nozzle, Stepped Tip, 7.1" overall length, 10.7 mm inner dimension, 24 elements; 1:1, 2:1 mix ratios – F Cartridges.
	1573135 1573131	10 1,000	200/400 ml Mix Nozzle, Stepped Tip, 7.6" overall length, 6.3 mm inner diameter, 24 elements; 1:1, 2:1 mix ratios – F Cartridges.
	1573138 1573136	10 1,000	200/400 ml Mix Nozzle, Stepped Tip, 9.2" overall length, 8 mm inner diameter, 24 elements; 1:1, 2:1 mix ratios – F Cartridges.
	1084255	10	200/400/490 ml Mix Nozzle, Stepped Tip, 9.2" overall length, 8 mm inner diameter, 24 elements; 4:1, 10:1 mix ratios – F Cartridges.
	1084092 1084093	10 900	200/400/490 ml Mix Nozzle, Stepped Tip, 11.2" overall length, 10 mm inner diameter, 24 elements; 4:1, 10:1 mix ratios – F Cartridges.
MIX NOZZLES FOR 300 ML SINGLE AXIS DUAL CARTRIDGES			
	1100962	3	300 ml Single-Axis Cartridge Mix Nozzle, Threaded Tip, 10" overall length, 11.2 mm inner diameter; 20 elements.
	1100963	3	300 ml Single-Axis Cartridge Mix Nozzle, Threaded Tip, 15.3" overall length, 14.3 mm inner diameter; 19 elements.
SPRAYABLE CERAMIC MIX NOZZLES			
	1248606	10	200/400 ml Spray Tip Mix Nozzle, 0.25" inner diameter, 24 elements for use with sprayable ceramic materials.
MIX NOZZLE ADAPTERS			
	720175 970655	10 2,000	Luer-Lok Adapter for 6 mm and 8 mm Stepped Tip Mix Nozzles, allows for Dispense Needle Attachment (10 pack). Mix Nozzles and Dispense Needles sold separately.

LOCTITE® BRAND SYRINGE ACCESSORIES

PRODUCT	Item Number	Description	Contents
	98656 98657 97208 97245	3 ml Syringe Air Line Adapter 5 ml Syringe Air Line Adapter 10 ml Syringe Air Line Adapter 30 ml and 55 ml Syringe Air Line Adapter	2 Air Line Adapters – Common to all part numbers (Syringe Barrel sold separately)
	984650	Air Line Filter for Syringe Dispensing to prevent product back-flow	1 Filter Assembly with 2 Hose Crimps
	97216	10 ml Syringe Starter Kit	5 Caps 5 Pistons 4 Clear Barrels 1 Black Barrel 5 Tips 1 Air Line Adapter
	97294	30 ml Syringe Starter Kit	
	98416	55 ml Syringe Starter Kit	
	97207	10 ml Clear Syringe Barrel Kit	20 Barrel Caps, 40 Pistons, 40 Barrels, 40 Barrel Tips
	97244	30 ml Clear Syringe Barrel Kit	10 Barrel Caps, 20 Pistons, 20 Barrels, 20 Barrel Tips
	98314	55 ml Clear Syringe Barrel Kit	5 Barrel Caps, 10 Pistons, 10 Barrels, 10 Barrel Tips
	97263	10 ml Black Syringe Barrel Kit for UV Adhesives	20 Barrel Caps, 40 Pistons, 40 Barrels, 40 Barrel Tips
	97264	30 ml Black Syringe Barrel Kit for UV Adhesives	10 Barrel Caps, 20 Pistons, 20 Barrels, 20 Barrel Tips
	98315	55 ml Black Syringe Barrel Kit for UV Adhesives	5 Barrel Caps, 10 Pistons, 10 Barrels, 10 Barrel Tips
	Various	Clear or Black 3, 5, 10, 30 and 55 ml Piston/ Syringe Combination Packages	See page 69 for Syringe and Piston options and item numbers.
	Various	Dark Amber Syringe and Piston options	Available upon request. Please contact your LOCTITE® Sales Representative or contact us at www.equipment.loctite.com .
	Various	LOCTITE® Manual Syringe Kits	Each kit contains Plunger, Stopper and Clear Barrel, unassembled. See page 69 for Syringe and Piston options and item numbers.
	98501	LOCTITE® Applicator Holder for 10 ml, 30 ml and 55 ml Syringe Barrels (Red)	1 Holder (Syringe Barrel and Air Line Adapter sold separately)

LOCTITE® BRAND SYRINGE ACCESSORIES (CONTINUED)

PRODUCT	Accessory Item Number	Description	Package Quantity	
LOCTITE® Pneumatic Syringe Barrel and Piston Kits (Dark Amber Syringes are also available in the same packages. Call 860.571.5174 for special orders.)	98479	3 ml Syringe Barrel and Piston, Natural	50	
	98480	3 ml Syringe Barrel and Piston, Natural	1,000	
	98481	3 ml Syringe Barrel and Piston, Black	50	
	98482	3 ml Syringe Barrel and Piston, Black	1,000	
	98483	5 ml Syringe Barrel and Piston, Natural	50	
	98484	5 ml Syringe Barrel and Piston, Natural	1,000	
	98485	5 ml Syringe Barrel and Piston, Black	50	
	98486	5 ml Syringe Barrel and Piston, Black	1,000	
	98487	10 ml Syringe Barrel and Piston, Natural	50	
	98488	10 ml Syringe Barrel and Piston, Natural	1,000	
	98489	10 ml Syringe Barrel and Piston, Black	50	
	98490	10 ml Syringe Barrel and Piston, Black	1,000	
	98491	30 ml Syringe Barrel and Piston, Natural	50	
	98492	30 ml Syringe Barrel and Piston, Natural	500	
	98493	30 ml Syringe Barrel and Piston, Black	50	
	98494	30 ml Syringe Barrel and Piston, Black	500	
	98495	55 ml Syringe Barrel and Piston, Natural	250	
	98496	55 ml Syringe Barrel and Piston, Natural	50	
	98497	55 ml Syringe Barrel and Piston, Black	50	
	98498	55 ml Syringe Barrel and Piston, Black	250	
	Pneumatic Syringe Barrel and Piston	98655	3 ml Syringe Barrel, Black	1,000
		98557	3 ml Syringe Barrel, Natural	1,000
		98576	5 ml Syringe Barrel, Black	1,000
		98559	5 ml Syringe Barrel, Natural	1,000
		98578	10 ml Syringe Barrel, Black	1,000
		98561	10 ml Syringe Barrel, Natural	1,000
		98122	30 ml Syringe Barrel, Black	500
		98563	30 ml Syringe Barrel, Natural	500
		98581	55 ml Syringe Barrel, Black	250
	98565	55 ml Syringe Barrel, Natural	250	
	Pneumatic Pistons Only	98125	3 ml Syringe Piston	1,000
		98584	5 ml Syringe Piston	1,000
		98127	10 ml Syringe Piston	1,000
98587		30 / 55 ml Syringe Piston	1,000	
LOCTITE® Manual Syringe Kits Each kit contains a plunger, stopper and barrel in the quantity indicated.	1180639	3 ml Clear Manual Syringe Kit	10	
	1176432	3 ml Clear Manual Syringe Kit	1,000	
	1180638	6 ml Clear Manual Syringe Kit	10	
	1176431	6 ml Clear Manual Syringe Kit	1,000	
	1180637	10 ml Clear Manual Syringe Kit	10	
	1180633	10 ml Clear Manual Syringe Kit	1,000	
	1180636	35 ml Clear Manual Syringe Kit	10	
	1180634	35 ml Clear Manual Syringe Kit	500	

Dispense Spare Parts

LOCTITE® BRAND DISPENSE SPARE PARTS

PARENT PRODUCT	Accessory Item Number	Description	Package Quantity
LOCTITE® Tubing	97970	3/8" Black PTFE-Lined Feed Tube	33 ft.
	97972	1/4" Black PTFE-Lined Feed Tube	33 ft.
	981821	1/4" Clear Polyethylene Feed Tube	33 ft.
	981866	3/8" Clear Polyethylene Feed Tube	33 ft.
	981994	1/4" Clear Nylon Feed Tube for Pump-A-Bead™ II	33 ft.
	984688	Silicone Tubing for Dispense Valve Purging (10 Pack)	1 ft.
986300 – LOCTITE® Poppet Valve, Acetal Copolymer Body	986025	Nozzle: 0.025" diameter	1
	986035	Nozzle: 0.035" diameter	1
	986060	Nozzle: 0.060" diameter	1
	986301	Valve Rebuild Kit	1

Robot Dispense Systems

Available in both Benchtop and SCARA model types, LOCTITE® brand robots are designed to simplify the dispensing of adhesives and sealants onto complex surface configurations. They allow manufacturers to repeatedly and reliably dispense patterns of liquid material on a programmed basis, resulting in improved process efficiencies, minimal material waste and reduced manufacturing costs.



Motion Control

ROBOT TYPES

Benchtop robots are beam or gantry style robots designed to be placed on a bench. These robots carry one or more parts that are captured in a fixture that is mounted on the work surface. Motion in the X axis is achieved by moving the work surface forward and backward. The Y and Z axes are achieved by moving the tool head left and right, and up and down, respectively, on the beam or gantry. When applicable, the fourth axis (R axis) is achieved by rotating the mounting shaft that protrudes from the tool head.

SCARA is an acronym for Selective Compliance Assembly Robot Arm. The robot is a multi-jointed arm that moves above the work surface. It must be mounted near the work surface by the user. The X and Y axes are achieved by changing the angles of the two arms. This creates a kidney-shaped dispensing area that is approximately 880 mm wide and 440 mm tall at the center. The Z axis is achieved by moving both arms up and down. On the 4-axis models, the R axis is achieved by rotating the mounting shaft that protrudes from the end of the arm.

For detailed dimension drawings of all benchtop robots, please visit the web at:

www.equipment.loctite.com

Just search on the part number you are interested in and scroll down to the product documentation.

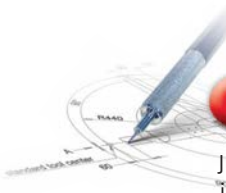

PRODUCT		LOCTITE® 200D BENCHTOP ROBOT	LOCTITE® 300D BENCHTOP ROBOT	LOCTITE® 400D BENCHTOP ROBOT	LOCTITE® 500D BENCHTOP ROBOT	LOCTITE® EQ RB20 500D DUAL BENCHTOP ROBOT	LOCTITE® EQ RB15 200D GANTRY ROBOT	LOCTITE® S440 SCARA-N ROBOT
ITEM NUMBER <i>(110 VOLT SYSTEMS)</i>	3-AXIS	1597107	1452395	1452396	1578317	1682223	1670898	1008351
	4-AXIS	-	-	-	-	N/A	N/A	1008338
TYPE		Benchtop	Benchtop	Benchtop	Benchtop	Benchtop	Gantry	SCARA
RANGE OF OPERATION	X AXIS	200 mm	300 mm	400 mm	500 mm	(2x) 250 mm	200 mm	Arm 1: 260 mm ± 90°
	Y AXIS	200 mm	320 mm	400 mm	500 mm	250 mm	200 mm	Arm 2: 180 mm ± 150°
	Z AXIS	50 mm	100 mm	150 mm	100 mm	500 mm	50 mm	100 mm
	R AXIS	-	-	-	-	N/A	N/A	± 360°
PORTABLE WEIGHT LIMITATIONS	WORK SURFACE	5.0 kg	10.0 kg	10.0 kg	10.0 kg	10.0 kg	N/A	N/A
	TOOL HEAD	2.0 kg	5.0 kg	5.0 kg	5.0 kg	5.0 kg	2.0 kg	5.0 kg
SPEED	PTP (X,Y) MAXIMUM	400 mm/s	600 mm/s	600 mm/s	600 mm/s	600 mm/s	400 mm/s	1500 mm/s
	PTP (Z) MAXIMUM	200 mm/s	320 mm/s	320 mm/s	320 mm/s	300 mm/s	200 mm/s	320 mm/s
	PTP (R)	-	-	-	-	N/A	N/A	10 to 1,000 °/s
ADDITIONAL INFORMATION		Please visit www.equipment.loctite.com for detailed drawings of all benchtop robots. Just search for the item number that you are interested in and scroll down to the product documentation.						

LOCTITE® 200D BENCHTOP ROBOT

Item Number: 1597107

The LOCTITE® 200D Series Benchtop Robot has a 200 mm by 200 mm range of operation. Eight different configurations, as shown in the chart, are available to meet your process requirements. This unit is fully compliant with Robotics Industry Association (RIA) safety guidelines. Programming accessories, dispensing equipment, integration cables and mounting hardware are sold separately.

Features:

- Designed for adhesive dispensing.
- Independent dispense On/Off purge control button on front panel allows adhesive to be purged from a dispense valve to prevent curing or for aiding initial setup. Great for purging of two-part materials that have a very short pot life. No special programming required.
- Integrated solution – plug and play accessories.
- Software utility program compensates for positional offsets when dispense needle tips or barrels are changed.
- Teach Pendant program storage capabilities allows dispense program to be easily transferred from robot to robot.
- Over-speed error indicator prevents robot from traveling too fast during the execution of the program.
- 100 programs, 4,000 points memory per program, compact flash card.
- Brush area function command allows the tip to “paint” a specifically designed area.
- Shortcut keys for common tasks.
- No programming experience required.



Integration Accessories

- Teach Pendant – 1328356

Your LOCTITE® 200D series includes one dispensing cable so you can hook up to any one of our following dispensing systems:

- LOCTITE® Solenoid Valve Module 12 V – 1328354.
- LOCTITE® Integrated Semiautomatic Dispensers – 1390321, 1390322.
- Precision Syringe Dispenser – 97006.
- Digital Syringe Dispenser – 883976 (Adapter Cable, item 1053227, also required).
- LOCTITE® Posi-Link™ Volumetric Syringe and Dual Cartridge Systems.
- LOCTITE® DuraPump™ Systems.

For additional integration, including low level signal operation, use:

- LOCTITE® D Series Interface Cable – 1329222.
 - 25-pin male “D shell” electrical connector that connects into rear of robot.
 - 3-pin female round connector that connects into robot.
 - 9-pin male “D shell” electrical connector that connects into Dispensing Unit or Solenoid Valve Module.
- LOCTITE® 24 Volt Interface Junction Box – 1461974.
- LOCTITE® Solenoid Valve Module for pneumatic control by the robot – 988000.

TECHNICAL SPECIFICATIONS		
Attribute		Value
Number of Controllable Axes		3
Range of Operation	X Axis	200 mm
	Y Axis	200 mm
	Z Axis	50 mm
Portable Weight	Work Surface	5.0 kg
	Tool Head	2.0 kg
Speed	PTP (X,Y) Max.	400 mm/s
	PTP (Z)	200 mm/s
Repeatability Accuracy	X, Y, Z Axis	± 0.04 mm
CPU		32 bit
Control Method		Point-to-Point or Continuous Path
Drive Method		3-phase stepping motor
I/O		8
Program Capacity		100 programs
Data Memory Capacity		4,000 points/program
Dimensions	Width, 3-Axis	350 mm
	Depth	330 mm
	Height, 3-Axis	490 mm
Weight		18 kg
Power Source – Auto Switching		95-250 VAC; 50/60 Hz
Power Consumption		150 VA
Working Environment	Temperature	0°C to 40°C
	Humidity	20% to 90% RH
Parts Included	(1) Robot (1) Power Cord (1) Dispense Cable (1) External Interlock Bypass Connector (1) CD-ROM Manual (1) Teach Pendant Cable (1) 30-55 ml Syringe Bracket and Mounting Screws	
Additional Information	Extensive Mounting Hardware options listed on page 79. See www.equipment.loctite.com for detailed dimension drawings.	

LOCTITE® 300D BENCHTOP ROBOT

Item Number: 1452395

The LOCTITE® 300D Series Benchtop Robot has a 300 mm by 320 mm range of operation. Eight different configurations, as shown in the chart, are available to meet your process requirements. This unit is fully compliant with Robotics Industry Association (RIA) safety guidelines. Programming accessories, dispensing equipment, integration cables and mounting hardware are sold separately.

Features:

- Designed for adhesive dispensing.
- Independent dispense On/Off purge control button on front panel allows adhesive to be purged from a dispense valve to prevent curing or for aiding initial setup. Great for purging of two-part materials that have a very short pot life. No special programming required.
- Integrated solution – plug and play accessories.
- Software utility program compensates for positional offsets when dispense needle tips or barrels are changed.
- Teach Pendant program storage capabilities allows dispense program to be easily transferred from robot to robot.
- Over-speed error indicator prevents robot from traveling too fast during the execution of the program.
- 100 programs, 4,000 points memory per program, compact flash card.
- Brush area function command allows the tip to “paint” a specifically designed area.
- Shortcut keys for common tasks.
- No programming experience required.



Integration Accessories

- Teach Pendant – 1328356

Your LOCTITE® 300D series includes one dispensing cable so you can hook up to any one of our following dispensing systems:

- LOCTITE® Solenoid Valve Module 24 V – 988000.
- LOCTITE® Integrated Semiautomatic Dispensers – 1390321, 1390322.
- Precision Syringe Dispenser – 97006.
- Digital Syringe Dispenser – 883976 (Adapter cable, 1053227, also required).
- LOCTITE® Posi-Link™ Volumetric Syringe and Dual Cartridge Systems.
- LOCTITE® DuraPump™ Systems.

For additional integration, including low level signal operation, use:

- LOCTITE® D Series Interface Cable – 1329222
 - 25-pin male “D shell” electrical connector that connects into rear of robot.
 - 3-pin female round connector that connects into robot.
 - 9-pin male “D shell” electrical connector that connects into Dispensing Unit or Solenoid Valve Module.
- LOCTITE® 24 Volt Interface Junction Box – 1461974.
- LOCTITE® Solenoid Valve Module for pneumatic control by the robot – 988000.

TECHNICAL SPECIFICATIONS		
Attribute		Value
Number of Controllable Axes		3
Range of Operation	X Axis	300 mm
	Y Axis	300 mm
	Z Axis	100 mm
Portable Weight	Work Surface	10.0 kg
	Tool Head	5.0 kg
Speed	PTP (X,Y) Max.	600 mm/s
	PTP (Z) Max.	320 mm/s
Repeatability Accuracy	X, Y, Z Axis	± 0.01 mm
CPU		32 bit
Control Method		Point-to-Point or Continuous Path
Drive Method		3-phase stepping motor
Program Capacity		100 programs
Data Memory Capacity		4,000 points/program
Dimensions	Width	485 mm
	Depth	500 mm
	Height, 3-Axis	600 mm
Weight		32 kg
Power Source – Auto Switching		95-250 VAC; 50/60 Hz
Power Consumption		150 VA
Working Environment	Temperature	0°C to 40°C
	Humidity	20% to 90% RH
Parts Included	(1) Robot (1) Power Cord (1) Dispense Cable (1) External Interlock Bypass Connector (1) CD-ROM Manual (1) Teach Pendant Cable (1) 30–55 ml Syringe Bracket and Mounting Screws	
Additional Information	Extensive Mounting Hardware options listed on page 79. See www.equipment.loctite.com for detailed dimension drawings.	

LOCTITE® 400D BENCHTOP ROBOT

Item Number: 1452396

The LOCTITE® 400D Series Benchtop Robot has a 400 mm by 400 mm range of operation. Eight different configurations, as shown in the chart, are available to meet your process requirements. This unit is fully compliant with Robotics Industry Association (RIA) safety guidelines. Programming accessories, dispensing equipment, integration cables and mounting hardware are sold separately.

Features:

- Designed for adhesive dispensing.
- Independent dispense On/Off purge control button on front panel allows adhesive to be purged from a dispense valve to prevent curing or for aiding initial setup. Great for purging of two-part materials that have a very short pot life. No special programming required.
- Integrated solution – plug and play accessories.
- Software utility program compensates for positional offsets when dispense needle tips or barrels are changed.
- Teach Pendant program storage capabilities allows dispense program to be easily transferred from robot to robot.
- Over-speed error indicator prevents robot from traveling too fast during the execution of the program.
- 100 programs, 4,000 points memory per program, compact flash card.
- Brush area function command allows the tip to “paint” a specifically designed area.
- Shortcut keys for common tasks.
- No programming experience required.

Integration Accessories

- Teach Pendant – 1328356

Your LOCTITE® 400D series includes one dispensing cable so you can hook up to any one of our following dispensing systems:

- LOCTITE® Solenoid Valve Module 24 V – 988000.
- LOCTITE® Integrated Semiautomatic Dispensers – 1390321, 1390322.
- Precision Syringe Dispenser – 97006.
- Digital Syringe Dispenser – 883976 (Adapter cable, 1053227, also required).
- LOCTITE® Posi-Link™ Volumetric Syringe and Dual Cartridge Systems.
- LOCTITE® DuraPump™ Systems.

For additional integration, including low level signal operation, use:

- LOCTITE® D Series Interface Cable – 1329222
 - 25-pin male “D shell” electrical connector that connects into rear of robot.
 - 3-pin female round connector that connects into robot.
 - 9-pin male “D shell” electrical connector that connects into Dispensing Unit or Solenoid Valve Module.
- LOCTITE® 24 Volt Interface Junction Box – 1461974.
- LOCTITE® Solenoid Valve Module for pneumatic control by the robot – 988000.



TECHNICAL SPECIFICATIONS		
Attribute		Value
Number of Controllable Axes		3
Range of Operation	X Axis	400 mm
	Y Axis	400 mm
	Z Axis	100 mm
Portable Weight	Work Surface	10.0 kg
	Tool Head	5.0 kg
Speed	PTP (X,Y) Max.	600 mm/s
	PTP (Z) Max.	320 mm/s
Repeatability Accuracy	X, Y, Z Axis	± 0.01 mm
CPU		32 bit
Control Method		Point-to-Point or Continuous Path
Drive Method		3-phase stepping motor
I/O		8
Program Capacity		100 programs
Data Memory Capacity		4,000 points/program
Dimensions	Width	584 mm
	Depth	600 mm
	Height	600 mm
Weight		40 kg
Power Source – Auto Switching		95-250 VAC; 50/60 Hz
Power Consumption		150 VA
Working Environment	Temperature	0°C to 40°C
	Humidity	20% to 90% RH
Parts Included	(1) Robot (1) Power Cord (1) Dispense Cable (1) External Interlock Bypass Connector (1) CD-ROM Manual (1) Teach Pendant Cable (1) 30–55 ml Syringe Bracket and Mounting Screws	
Additional Information	Extensive Mounting Hardware options listed on page 79. See www.equipment.loctite.com for detailed dimension drawings.	

LOCTITE® 500D BENCHTOP ROBOT

Item Number: 1578317

The LOCTITE® 500D Series Benchtop Robot has a 500 mm by 500 mm range of operation. Eight different configurations, as shown in the chart, are available to meet your process requirements. This unit is fully compliant with Robotics Industry Association (RIA) safety guidelines. Programming accessories, dispensing equipment, integration cables and mounting hardware are sold separately.

Features:

- Designed for adhesive dispensing.
- Independent dispense On/Off purge control button on front panel allows adhesive to be purged from a dispense valve to prevent curing or for aiding initial setup. Great for purging of two-part materials that have a very short pot life. No special programming required.
- Integrated solution – plug and play accessories.
- Software utility program compensates for positional offsets when dispense needle tips or barrels are changed.
- Teach Pendant program storage capabilities allows dispense program to be easily transferred from robot to robot.
- Over-speed error indicator prevents robot from traveling too fast during the execution of the program.
- 100 programs, 4,000 points memory per program, compact flash card.
- Brush area function command allows the tip to “paint” a specifically designed area.
- Shortcut keys for common tasks.
- No programming experience required.



Integration Accessories

- Teach Pendant – 1328356

Your LOCTITE® 500D series includes one dispensing cable so you can hook up to any one of our following dispensing systems:

- LOCTITE® Solenoid Valve Module 24 V – 988000.
- LOCTITE® Integrated Semiautomatic Dispensers – 1390321, 1390322.
- Precision Syringe Dispenser – 97006.
- Digital Syringe Dispenser – 883976 (Adapter cable, 1053227, also required).
- LOCTITE® Posi-Link™ Volumetric Syringe and Dual Cartridge Systems.
- LOCTITE® DuraPump™ Systems.

For additional integration, including low level signal operation, use:

- LOCTITE® D Series Interface Cable – 1329222
 - 25-pin male “D shell” electrical connector that connects into rear of robot.
 - 3-pin female round connector that connects into robot.
 - 9-pin male “D shell” electrical connector that connects into Dispensing Unit or Solenoid Valve Module.
- LOCTITE® 24 Volt Interface Junction Box – 1461974.
- LOCTITE® Solenoid Valve Module for pneumatic control by the robot – 988000.

TECHNICAL SPECIFICATIONS		
Attribute	Value	
Number of Controllable Axes	3 to 4	
Range of Operation	X Axis	500 mm
	Y Axis	500 mm
	Z Axis	100 mm
Portable Weight	Work Surface	10.0 kg
	Tool Head	5.0 kg
Speed	PTP (X,Y)	600 mm/s
	PTP (Z)	320 mm/s
	CP (X,Y, Z)	0.1 to 800 mm/s
Repeatability Accuracy	X, Y, Z Axis	± 0.01 mm, 3 Sigma
CPU	32 bit	
Control Method	Point-to-Point or Continuous Path	
Drive Method	3-phase stepping motor	
I/O	8 Inputs / 8 Outputs	
Program Capacity	100 programs	
Data Memory Capacity	4,000 points	
Dimensions	Width	685 mm
	Depth	701 mm
	Height, 3-Axis	599 mm
Weight	45 kg	
Power Source – Auto Switching	95-132 VAC; 150 Watt 180-250 VAC; 150 Watt	
Power Consumption	150 VA	
Working Environment	Temperature	0°C to 40°C
	Humidity	20% to 90% RH
Parts Included	(1) Robot (1) Power Cord (1) Dispense Cable (1) External Interlock Bypass Connector (1) CD-ROM Manual (1) Teach Pendant Cable (1) 30–55 ml Syringe Bracket and Mounting Screws	
Additional Information	Extensive Mounting Hardware options listed on page 79. See www.equipment.loctite.com for detailed dimension drawings.	
Additional Accessories Sold Separately	988000 – Solenoid Valve Module for pneumatic control by the robot	

LOCTITE® EQ RB20 500D DUAL BENCHTOP ROBOT

Item Number: 1682223

The LOCTITE® EQ RB20 500D Dual Benchtop Robot is identical to existing Loctite 500D robot, except it has two independent working tables on the Y-axis for increased throughput. The range of operation is 500 mm by 500 mm by 100 mm (X-Y-Z).

Features:

- Two Y-axes, increases throughput.
- No downtime from loading and unloading.
- Designed for adhesive dispensing.
- Greater load capacity than a pair of 200D robots.
- Independent dispense On/Off purge control button on front panel allows adhesive to be purged from a dispense valve to prevent curing or for aiding initial setup. No special programming required. Useful for setup and purging of two-part materials that have a very short pot life.
- Needle tip calibration available.
- 100 programs, 4,000 points memory per program.
- Teach Pendant program storage capabilities allows dispense program to be easily transferred from Robot to Robot.
- Low-cost robot has 3-axis control and 120 VAC or 220 VAC operation with a 24 VDC output signal.
- A wide variety of mounting hardware is available; see page 79.

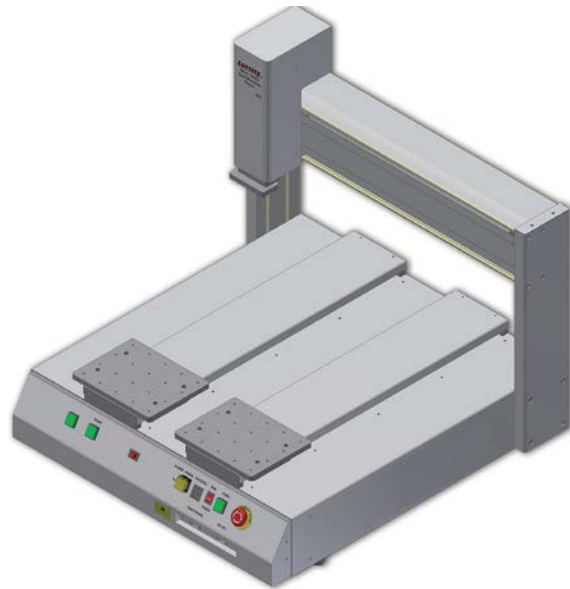

Programming

The Robot utilizes a specially designed, multi-line, Teach Pendant that allows for simple programming with user-friendly prompts. The Operating Manual provides step-by-step instructions for programming. No previous programming experience is required.

Integration Accessories (not included)

LOCTITE® brand cables and junction boxes provide plug-and-play Integration solutions for a variety of LOCTITE® dispensing systems.

- 1328356 Teach Pendant for 200D, 300D, 400D & 500D Benchtop Robots.
- 1461974 Robot I/O Junction Box for 200D, 300D, 400D & 500D Robots. Provides a convenient connection point between robots and up to 8 external devices including all LOCTITE® dispensers, UV Wands, LOCTITE® light curtains, LED cure systems, Posi-Link™ Volumetric Dispensing System. Allows multiple system integration simultaneously. This junction box accepts up to 8 inputs and 8 outputs, 24 VDC operation.
- 1569523 The Robot Needle Calibration Kit is designed to allow the user to quickly calibrate needle tip location after change over. The Kit is designed to work with LOCTITE® 24V D-Series Robots, which are equipped with software version H1.30 or higher.
- 1329222 Interface Cable for 200D, 300D, 400D & 500D Benchtop Robots.
- 988000 Solenoid Valve Module, 24 VDC operation for 200D, 300D, 400D & 500D General Purpose Benchtop Robots.

TECHNICAL SPECIFICATIONS		
Attribute	Value	
Dimensions	Width	685 mm
	Depth	715 mm
	Height, 3-Axis	670 mm
Weight	70 kg	
Load	Table	10.0 kg
	Z-Axis	5.0 kg
Maximum Speed	PTP (X,Y)	600 mm/s
	PTP (Z)	300 mm/s
Repeatability Accuracy	X, Y, Z Axis	±0.02 mm
Resolution	X, Y, Z Axis	0.02 mm
Data Memory Capacity	4,000 points	
Program Capacity	100 programs	
Program System	USB 2.0 Memory Stick	
CPU	32 bit	
Display	Teach Pendant LCD	
Drive System/Stepping Motor	Micro stepping 3-Phase	
Motion Control	PTP & CP	
Linear/Circular Interpolation	3 Axes	
I/O Signals	8 Inputs / 8 Outputs	
Teaching Method	Teach Pendant	
External Interface	RS232	
Power Supply	110~220 VAC 300W	
Working Temperature	10°C to 40°C	
Relative Humidity (no condensation)	20% to 90%	
Parts Included	(1) Robot (1) Power Cord (1) Dispense Cable (1) External Interlock Bypass Connector (1) CD-ROM Manual (1) Teach Pendant Cable (1) 30-55 ml Syringe Bracket and Mounting Screws	
Additional Information	Extensive Mounting Hardware options listed on page 79. See www.equipment.loctite.com for detailed dimension drawings.	

LOCTITE® EQ RB15 200D GANTRY ROBOT

Item Number: 1670898

The LOCTITE® EQ RB15 200D Gantry Robot has features and accessories that are custom tailored for adhesive dispensing processes. The gantry configuration makes it ideal for integration with automatic transfer lines and conveyors. It is compatible with a wide variety of LOCTITE® dispense valves, reservoirs and curing lights, and can be easily integrated to other external devices or systems when used with a LOCTITE® I-O Junction Box.

Features:

- Designed for adhesive dispensing.
- Compact design with remote controller configuration
- Teach Pendant programmable with easy-to-use programming software. Shortcut keys for common tasks.
- All programs are stored on the Teach Pendant, which allows dispense programs to be easily transferred from Robot to Robot.
- Up to 100 programs can be stored on the Teach Pendant.
- Independent dispense On/Off purge button on the front panel allows adhesive to be purged from a dispense valve to prevent curing and aid in the initial setup. No special programming required. Useful for setup and purging of two-part materials that have a very short pot life.
- Easily integrates with the LOCTITE® Needle Calibration Kit (#1569523) for precise dispense tip location.
- The LOCTITE® I-O Junction Box (#1461974), can be installed together with automatic conveyors and other production equipment.
- A wide variety of mounting hardware is available; see page 79.

Integration Accessories (not included)

LOCTITE® brand cables and junction boxes provide plug-and-play Integration solutions for a variety of LOCTITE® dispensing systems.

- 1328356 Teach Pendant for 200D, 300D, 400D & 500D Benchtop Robots.
- 1461974 Robot I/O Junction Box for 200D, 300D, 400D & 500D Robots. Provides a convenient connection point between robots and up to 8 external devices including all LOCTITE® dispensers, UV Wands, LOCTITE® light curtains, LED cure systems, Posi-Link™ Volumetric Dispensing System. Allows multiple system integration simultaneously. This junction box accepts up to 8 inputs and 8 outputs, 24 VDC operation.
- 1569523 The Robot Needle Calibration Kit is designed to allow the user to quickly calibrate needle tip location after change over. The Kit is designed to work with LOCTITE® 24V D-Series Robots, which are equipped with software version H1.30 or higher.
- 1329222 Interface Cable for 200D, 300D, 400D & 500D Benchtop Robots.
- 988000 Solenoid Valve Module, 24 VDC operation for 200D, 300D, 400D & 500D General Purpose Benchtop Robots.



TECHNICAL SPECIFICATIONS		
Attribute		Value
Working Area	Width	200 mm
	Depth	200 mm
	Height, 3-Axis	50 mm
Weight		16 kg
Load	Table	5.0 kg
	Z-Axis	2.0 kg
Maximum Speed	PTP (X,Y)	400 mm/s
	PTP (Z)	200 mm/s
Repeatability Accuracy	X, Y, Z Axis	±0.04 mm
Resolution	X, Y, Z Axis	0.02 mm
Data Memory Capacity		4,000 points
Program Capacity		100 programs
Program System		Compact Flash Card
Processor		32 bit
Display		Teach Pendant LCD
Drive System/Stepping Motor		Micro stepping 3-Phase
Motion Control		PTP & CP
Linear/Circular Interpolation		3 Axes
I/O Signals		8 Input / 8 Output
Teaching Method		Teach Pendant
External Interface		RS232
Power Supply		110~220 VAC 320W
Working Temperature		0°C to 40°C, 0°F to 104°F
Relative Humidity (no condensation)		20% to 90%
Dimensions (W x D x H mm)		250 x 300 x 130 Controller
		469 x 389 x 189 Robot
Parts Included	(1) Robot (1) Power Cord (1) Dispense Cable (1) External Interlock Bypass Connector (1) CD-ROM Manual (1) Teach Pendant Cable (1) 30–55 ml Syringe Bracket and Mounting Screws	
Additional Information	Extensive Mounting Hardware options listed on page 79. See www.equipment.loctite.com for detailed dimension drawings.	

LOCTITE® S440 SCARA-N ROBOT

The LOCTITE® S440 Series SCARA-N Robot provides maximum flexibility for complex dispensing applications. The robot features a multi-jointed arm that moves above the work surface. The robot dispensing area is a kidney-shaped area determined by the two arm lengths. Eight different configurations, as shown in the chart, are available to meet your process requirements. Programming accessories, dispensing equipment, cables and mounting hardware are sold separately.

Robot Configurations

Item Number	Description
1008351	SCARA-N, 440 mm, 3-axis, 110 V
1008340	SCARA-N, 440 mm, 3-axis, 110 V CE Rated
1008339	SCARA-N, 440 mm, 3-axis, 220 V
1008552	SCARA-N, 440 mm, 3-axis, 220 V CE Rated
1008338	SCARA-N, 440 mm, 4-axis, 110 V
1008337	SCARA-N, 440 mm, 4-axis, 110 V CE Rated
1008335	SCARA-N, 440 mm, 4-axis, 220 V CE Rated

Features:

- Integrated solution – plug and play.
- Low-cost operation and ownership.
- Compact size.
- Application-specific software.
- Teach Point programming.
- A 255-program, 30,000-point memory card.
- A wide variety of mounting hardware is available; see page 79.

Programming

Simple to program using either a multi-line backlit Teach Pendant with user-friendly prompts or Windows XP® software. The program allows for continuous path motion and automatically interpolates any line or arc in all axes. The manual provides step-by-step instructions for programming the robot. No previous experience is required.

Programming Accessories

The operations box is required. The specially designed, easy-to-use Teach Pendant is the preferred device for programming and operating the robot. A laptop computer loaded with the Teach Point Software can also be used as an alternative.

987512 – Operations Box 1015106 – Teach Pendant

989656 – LR-C Teach Point Software

Integration Accessories

LOCTITE® brand cables and junction boxes provide plug-and-play integration solutions for a variety of LOCTITE® dispensing systems. Single- or multiple-system's functionality can be easily accommodated.

98395 Interface Cable – SCARA Robots, 37 pin male D x multi. Use with all LOCTITE® Robots **single dispenser** integration. Integrates LOCTITE® Precision Syringe Dispenser (97006), Digital Syringe Dispenser (883976), Spray Controller (1406023), Integrated Semiautomatic Controllers (1390321 and 1390322), Benchtop Peristaltic Dispenser (98548), and Posi-Link™ Controller (98377). Also, a separate cable is provided for integration with LOCTITE® Robot Guarding Systems.

98549 Robot Interface Junction Box. Provides convenient connection point between robots and up to 12 external devices, including all LOCTITE® dispensers, UV Wands, LED cure systems, and third- party solenoids, grippers, etc. The Junction Box accepts up to seven inputs and five outputs, device status indicator lights with a view window, and a 500 ma/24 VDC power supply for powering third-party devices.

Cable for Connection of the Junction Box to the SCARA Robot is provided with Robot Interface Junction Box (98549).

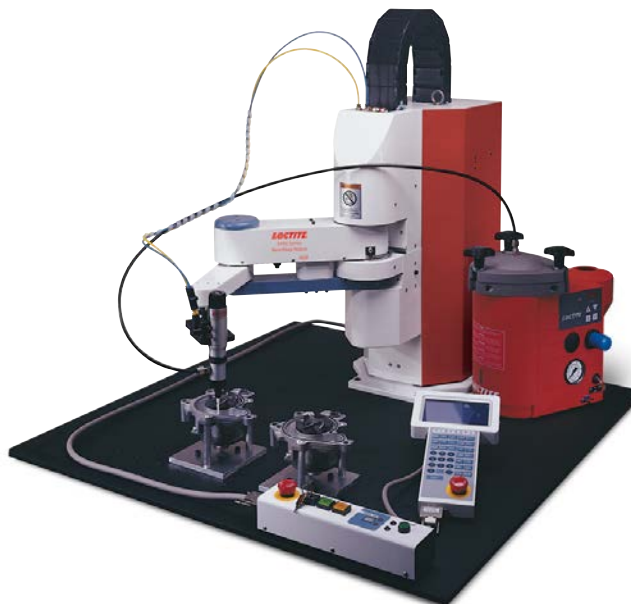

TECHNICAL SPECIFICATIONS		
Attribute	Value	
Number of Controllable Axes	3 to 4	
Range of Operation	X Axis	260 mm ± 90°
	Y Axis	180 mm ± 150°
	Z Axis	100 mm
	R Axis	± 360°
Portable Weight	Tool Head	5.0 kg
Speed	PTP (X,Y)	15 to 1,500 mm/s
	PTP (Z)	3.2 to 320 mm/s
	PTP (R)	1 to 1,000 °/s
	CP (X,Y, Z)	0.1 to 800 mm/s
Repeatability Accuracy	X, Y, Z Axis	± 0.01 mm
	R Axis	± 0.02°
CPU	32 bit	
Control Method	Point-to-Point or Continuous Path	
Drive Method	5-phase stepping motor	
I/O	16 + 8 + Safety	
Program Capacity	255 programs	
Data Memory Capacity	30,000 points	
Dimensions	Width	290 mm
	Depth	773 mm
	Height	840 mm
Weight	41 kg	
Power Source	110/220 VAC; 50/60 Hz	
Power Consumption	200 VA	
Working Environment	Temperature	0°C to 40°C
	Humidity	20% to 95% RH
Parts Included	(1) Power Cord (1) CD-ROM Manual	(1) Robot (1) I/O - S Short Plug
Additional Information	Extensive Mounting Hardware options listed on page 79. See www.equipment.loctite.com for detailed dimension drawings.	
Additional Accessories Sold Separately	988000 – Solenoid Valve Module for pneumatic control by the robot	

Dispense Stations

When a circular dispense pattern is required, LOCTITE® motion control systems offer robust performance at a lower cost than robotic dispense stations. They are simple to set up and operate, and their rugged construction makes them well-suited for harsh manufacturing environments.

In less complex applications and when a circular dispense pattern is required, these LOCTITE® systems offer a more economical choice than full robotic dispense stations.



LOCTITE® EQ RB10 ROTARY DISPENSE SYSTEM

Item Number: 1635546

The LOCTITE® EQ RB10 Rotary Dispense System is used for repetitive dispensing of circles or arcs. It is a fully integrated system that will directly control a cartridge or dispense valve and will operate any LOCTITE® Syringe Dispensing System. The rugged all-metal construction is designed for tough manufacturing environments and the all-digital control panel simplifies setup.

Features:

- Integrated Solution – plug and play with LOCTITE® Valves, Reservoirs and Syringe Systems.
- Digital Control of rotation, dispense start and stop and delays.
- Adjustable height, position, angle of dispense and advance slide speed.
- Reservoir low-level interface with cycle interruption and display message.
- Part position sensing allows orientation of adhesive bead start and end.
- Threaded and non-threaded mounting holes for fixtures.
- Operator lockout for supervisory control of settings.
- Dispense valve and syringe mounting hardware available.
- Accepts all LOCTITE® Robot Mounting hardware, see page 79.



VARIABLE	RANGE
Slide down time/ Turntable on	0.01 seconds to 99.99 seconds
Delay time before dispense	0.01 seconds to 99.99 seconds
Dispense time	0.01 seconds to 99.99 seconds

Required Separate Purchases

- Dispense valve, reservoir, syringe system or cartridge adapter.
- Valve/Syringe mounting bracket.
- Dispense needles.
- Fixture to locate part(s).

TECHNICAL SPECIFICATIONS		
Dispense Pattern	Circles or Arcs in a Circular Pattern	
Rotating Speed	0–999 Degrees	
Slide Stroke	0–2" (0 – 50 mm)	
Maximum Part Height	12" (305 mm)	
Maximum Part Weight	6 lbs. (2.7 kg)	
Dimensions	Width	12" (305 mm)
	Depth	8¾" (222 mm)
	Height	22" (559 mm) Minimum 25" (635 mm) Maximum
Weight	18.5 lbs. (8.4 kg)	
Air Input	Clean, dry air not to exceed 125 psig (8.5 bar), and filtered with a maximum of 50 micron.	
Power	Supply	110-230 VAC / 50-60 Hz.
	Internal	24 VDC
Parts Included	(1) Dispense System (1) Foot Switch (1) Power Supply with Cord (1) Instructional Manual	

LOCTITE® BRAND MOUNTING HARDWARE & GUARDING ENCLOSURES

Mounting Bracket Kits

Mounting bracket kits are used to grasp syringe barrels, LOCTITE® Posi-Link™ syringe and dual cartridge nests, 300 ml cartridges, dispense valves, and LEDs. Mounting rails or adapters are required to mount the brackets on the robot or dispense station.

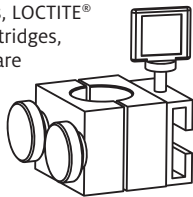

Item #	Description
98316	30 ml syringe mounting bracket kit
98318	300 ml cartridge mounting bracket kit
98326	98009 and 98013 valve mounting bracket kit
98327	97113 and 97114 valve mounting bracket kit
98406	983914 and 986300 poppet valve mounting bracket kit
98441	98520 spray and 98084 micro needle valve mounting bracket kit
98646	Universal syringe bracket for Posi-Link™
98647	50 ml dual cartridge bracket for Posi-Link™
1034030	CureJet™ mounting bracket kit
1638885	EQ VA10 mounting bracket

3, 5 and 10 ml Syringe Adapters

These adapters are inserted into the 30 ml syringe mounting bracket kit to adapt it for 3, 5 and 10 ml syringes. The 30 ml syringe mounting bracket (item 98316) must be purchased separately.

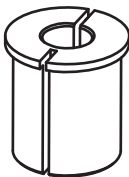

Item #	Description
98320	10 ml adapter for use with 98316
98321	5 ml adapter for use with 98316
98322	3 ml adapter for use with 98316

Mounting Adapter for All 4-Axis Robots

A mounting adapter is required when using LOCTITE® brand mounting hardware for all 4-axis robots. The mounting adapter includes a 360-degree rotation kit.

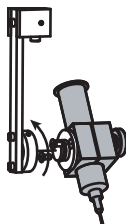

Item #	Description
98336	Mounting adapter for 4-axis robots

Complete Mounting Kits for 3-Axis SCARA Robots*

Complete mounting adapter kits hold the syringe, cartridge or valve, and position the dispense tip 60 mm from the end of the tool arm.

Item #	Description
98343	97113 and 97114 valve holder
98408	983914 and 986300 poppet valve holder

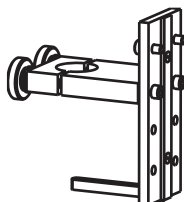

* These are sized for 25 gauge needles and must be modified by the user for larger gauge sizes.

Robot Needle Calibration Kit

Electronic system integrates with D-Series robots for precise, repeatable tip location.



Item #	Description
1569523	Robot Needle Calibration Kit

Z Height Adjustment Plate for 3-Axis Benchtop Robots

This plate allows you attach the mounting rails above or below the mounting bracket on the robot.

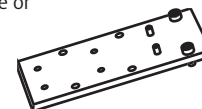

Item #	Description
98357	Z height adjustment plate

Mounting Rails for 3-Axis Benchtop Robots and Dispense Stations

A mounting rail is required when using LOCTITE® brand mounting hardware for all 3-axis Benchtop Robots and Dispense Stations.

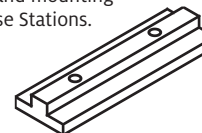

Item #	Description
98328	3/4" bar with two cap screws
98329	8/4" bar with two cap screws

Guarding Systems

FOR PLANTS REQUIRING HIGHER SAFETY LEVELS

- Light Curtain or Interlocked Sliding Door* on front
- Sturdy extruded aluminum frame
- Polycarbonate panels on left, right and rear
- Operator control panel mounted on front right
- Direct plug-in to robots



* Interlocked door model for Benchtop units only.











Item #	Description	Dimensions
989787	200 Series Slide Door Guarding System	22" W x 26" D x 27" H
989763	200 Series Light Curtain Guarding System	22" W x 24" D x 27" H
989788	300 Series Slide Door Guarding System	30" W x 32" D x 30" H
989771	300 Series Light Curtain Guarding System	30" W x 30" D x 30" H
989789	400/500 Series Slide Door Guarding System	32" W x 36" D x 35" H
989777	400/500 Series Light Curtain Guarding System	32" W x 38" D x 35" H
989852	SCARA Light Curtain Guarding System	48" W x 48" D x 36" H

Light Cure Solutions



Henkel offers the widest selection of light curing equipment available from any one company on the market today. Our LOCTITE® brand ensures you have the most innovative and dependable systems for all your light curing adhesive applications. Whether your process calls for a manual, semiautomatic or fully integrated automatic solution, you will find the LOCTITE® brand light curing device to meet your specific requirements. Please see the charts below, which summarize our complete line.









Light Cure



PRODUCT		Item Number	Wavelength	Options/Accessories
<i>LED Light Curing Devices – High-powered benchtop and portable systems for visible light cure adhesives, providing effective spot-curing solutions for both manual or integrated automatic systems.</i>				
	LOCTITE® 7700 LED Light Source	1427231	LED – 405 nm	OPTIONAL: Foot Switch – 98440; Holder – 98522; Radiometer Dosimeter for Visible LED and UVW Light – 1265282; Dosimeter Adapter – 1403405
	LOCTITE® 7700-HD LED Light Source	1427232		
	LOCTITE® Indigo® 7703 LED Light Source	806038	LED – Proprietary Indigo Wavelength	ONE OF THE FOLLOWING IS REQUIRED: Timer – 960356; PLC Cable – 8900550; Foot Switch – 97201; Pistol Grip Timer – 1003327
	LOCTITE® Indigo® 7703-HD LED Light Source	883979		
	LOCTITE® CureJet™ 375 LED	1369539	LED – 375 nm	Used with 1364033 or 1180632
	LOCTITE® CureJet™ 405 LED	1369538	LED – 405 nm	Used with 1364033 or 1180632
	LOCTITE® CureJet™ Indigo® LED	1369537	LED – Proprietary Indigo Wavelength	Used with 1364033 or 1180632
	LOCTITE® LED Controller	1364033	N/A	Used with all CureJet™ LEDs
	LOCTITE® CureJet™ Quad Controller	1180632	N/A	Used with all CureJet™ LEDs
	LOCTITE® LED Flood Controller	1359255	N/A	Used with 1167582, 1167589 or 1167593
	LOCTITE® LED Flood Cure, 375	1167582	LED – 375 nm	Used with 1359255 in conjunction with cable 1333333
	LOCTITE® LED Flood Cure, Indigo®	1167589	LED – Indigo Wavelength	Used with 1359255 in conjunction with cable 1333333
	LOCTITE® LED Flood Cure, 405	1167593	LED – 405 nm	Used with 1359255 in conjunction with cable 1333333
	LOCTITE® Single Line Array LED – Controller	1447728	N/A	Used with 1449336 or 1449337
	LOCTITE® Single Line Array LED – 365	1449337	LED – 365 nm	Used with 1447728
	LOCTITE® Single Line Array LED – 405	1449336	LED – 405 nm	Used with 1447728



* Up to four arrays may be used with Expansion Modules. Order item # 1488502.

PRODUCT		Item Number	Wavelength	Options/Accessories
Wand Systems – Three different spot curing systems with a range of wave lengths are ideal for both manual or integrated automatic systems.				
	LOCTITE® EQ CL10 Single LED Controller	1514636	LED-365 nm and 405 nm	Used with 1538499
	LOCTITE® EQ CL10 Quad LED Controller	1514634	LED-365 nm and 405 nm	Used with 1538499
	LOCTITE® EQ CL15 UV Wand system	1661548	100-watt High Pressure Mercury Arc – 250 to 450 nm	ONE OF THE FOLLOWING IS REQUIRED: Light Guide 5 mm x 1,500 mm – Item No. 951681 For other Light Guide options, visit www.equipment.loctite.com .

PRODUCT	Item Number	Lamp Type
CURE CHAMBERS & FLOOD SYSTEMS – These systems are ideal for batch processing. UV and alternate visible light bulb options are available.		
	LOCTITE® 7401 UV Chamber	98039 400 watt Metal Halide
	LOCTITE® 7411-S UV Flood System	98413 400 watt Metal Halide
	LOCTITE® Focused UV Flood Curing System	1113131 400 watt Metal Halide

PRODUCT	Item Number	Lamp Type
LIGHT METERS – UV and visible light cure systems. These meters provide precise and repeatable measurement of any LOCTITE® brand light cure system to ensure your process remains in control.		
	LOCTITE® Radiometer Dosimeter for UV LED and UV A/B Light	1390323 320 to 400 nm
	LOCTITE® Radiometer Dosimeter for Visible LED and UVV Light	1265282 350 to 500 nm
	LOCTITE® 7020 UV Spot Radiometer	1406024 280 to 400 nm / 3, 5 and 8 mm Light Guides

PRODUCT	Item Number	Lamp Type
CURE CONVEYORS – Can be used for either continuous or batch processing of assemblies.		
	LOCTITE® 7415 UV Benchtop Conveyor	98003 300 W/in. Electrodeless (Sold Separately)
	LOCTITE® UV Curing Conveyor	1241543 1,800 watt Medium Pressure Mercury Arc Lamp

HIGH INTENSITY LIGHT SOURCES – Can be used with our LOCTITE® ZETA® UV conveyors or integrated into a custom system with added shielding, cooling and venting (not included with these products).			
	LOCTITE® Electrodeless Lamp Assembly and Power Supply	98004 (208 VAC)	300 W/in. Electrodeless
	LOCTITE® Electrodeless Lamp Assembly and Power Supply	98005 (240 VAC)	300 W/in. Electrodeless
	LOCTITE® High Intensity Ultraviolet Sources	980160	1,500 watt Medium Pressure Mercury Arc Lamp

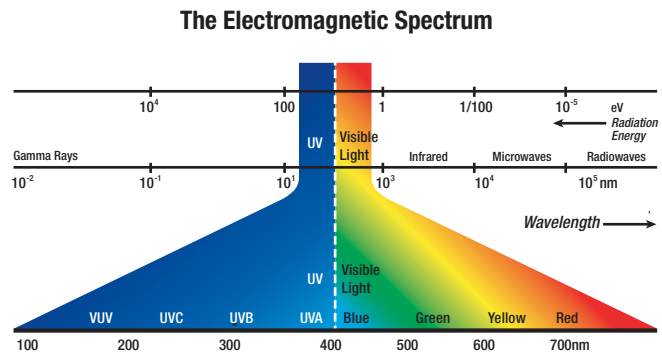

For proper eye protection, use LOCTITE® brand Safety Glasses.



98452 – UV & Visible Light Safety Glasses, Orange

LED Light Curing Devices

Henkel has introduced these new innovative and effective LED light curing devices. High power, portability, continuous-duty cycles and long LED life are some of the key reasons that make LOCTITE® brand LED light sources the optimal solution for many light curing adhesive applications.



LOCTITE® POINT LIGHT SOURCES

LOCTITE® 7700 LED LIGHT SOURCE

Item Number: 1427231



Light- to medium-duty
use cycles: <50% on time.

LOCTITE® INDIGO® 7703 LED LIGHT SOURCE

Item Number: 806038



Light- to medium-duty
use cycles: <50% on time.

These high-powered, fully portable, handheld light sources are capable of curing a variety of UV/visible adhesives in a matter of seconds. With the focused nature of this system's spectral output, 100% of the LED light output is within the usable curing spectrum of LOCTITE® adhesives. Part assembly heating is virtually eliminated. Lightweight and compact in size, these units provide extensive use flexibility for even the most crowded or hard-to-reach locations.

Features:

- Instant On/Off – no warm-up like traditional UV systems.
- LED life lasts up to 10 times longer than typical UV bulb units.
- Pinpoint tip allows close exposures even in the tightest locations.

See Intensity Profile
Graph on page 83.

LOCTITE® Light Cure Adhesives typically cured using:**

Item Number: 1427231

- | | | | | | | | |
|--------------------------------------|-----------------|---------|---------|---------|----------|---------|----------|
| • All LOCTITE® Flashcure® Adhesives† | • 3106™ (3321™) | • 3525™ | • 3526™ | • 3926™ | • 3943™ | • 3974™ | • 3979™† |
| • 3105™ (3311™) | • 3107™ (3341™) | • 3494™ | • 3921™ | • 3922™ | • 3924™ | • 3944™ | • 3971™† |
| | | | • 3924™ | • 3924™ | • 3972™† | • 5055™ | • 5056™ |

Item Number: 806038

- 3554™
- 3555™†
- 3556™†

OPERATIONAL OPTIONS

1427231 and 806038 operate on batteries or while plugged into AC power source.

Optional timer or foot switch
is also available.



960356 – LED Timer
Includes Foot Switch
97201 and (1) LED
Connection Cable





98440 –
Foot Switch

TECHNICAL SPECIFICATIONS

Item Number	1427231 – LOCTITE® 7700 LED Light Source	806038 – LOCTITE® Indigo 7703 LED Light Source
Dimensions	9" L x 1.1" W x 0.81" H	
Weight	0.5 lbs.	
Utilities	Batteries or Universal 110-240 V; 47-263 Hz	
Light Source	High-Powered LED	
Typical Intensity*	2.5-3.0 W/cm ² at 4 mm distance (See Intensity Profile Graph on page 80.)	
Spectral Output Range	380 to 415; Primary Peak 395 nm*	Proprietary

Additional Accessories Sold Separately

	98452 – LOCTITE® UV & Visible Light Safety Glasses (Removes all wavelengths 200 nm to 540 nm)
	1265282 – LOCTITE® Radiometer Dosimeter for Visible LED and UV Light
	98522 – LOCTITE® LED Holder
8900494 – Replacement Battery Kit 989620 – AC Battery Charger 1403405 – LOCTITE® Dosimeter Adapter 967055 – LED Protective Tip Covers (5 pack)	

* Values denote typical expected intensities and are not a fixed specification. Exact output measurement is dependent on the brand and calibration method of the meter used and normal variation of the Light Emitting Diodes. These measurements were made with a LOCTITE® Radiometer Dosimeter, 1265282. As with all applications, testing with your specific part and adhesive is recommended.

** Henkel recommends customers test all new adhesive applications under simulated or actual end-use conditions to ensure the adhesive meets or exceeds all required product specifications. This data was generated under highly controlled laboratory conditions, and may not represent actual assembly conditions.

† Tack-free.

For additional information and the full line of equipment, visit www.equipment.loctite.com.

LOCTITE® POINT LIGHT SOURCES

LOCTITE® 7700-HD LED LIGHT SOURCE

Item Number: 1427232



Heavy continuous duty cycles: Up to 100% on time.

LOCTITE® INDIGO® 7703-HD LED LIGHT SOURCE

Item Number: 883979



Heavy continuous duty cycles: Up to 100% on time.

These heavy-duty point light source LED models provide the same intensity and curing characteristics as the battery-powered 1427231 unit, but offer 100% on-time duty cycle capability. Ideal for process line integrations, these units also have alternate operational choices for cycle initiation to meet various processing requirements.

Features:

- Instant On/Off – no warm-up like traditional UV systems.
- LED life lasts up to 10 times longer than typical UV bulb units.
- Pinpoint tip allows close exposures even in the tightest locations.

7700 Series Intensity Profile*

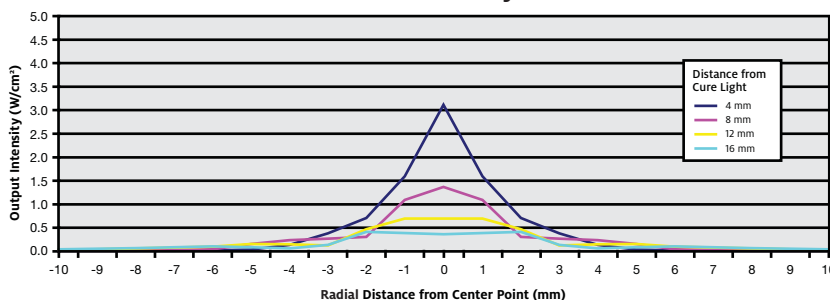

LOCTITE® Light Cure Adhesives typically cured using:**

Item Number: 1427232

- All LOCTITE® Flashcure® Adhesives†
- 3105™ (3311™)
- 3106™ (3321™)
- 3107™ (3341™)
- 3109™ (3349™)
- 3525™
- 3526™
- 3921™
- 3922™
- 3924™
- 3926™
- 3943™
- 3944™
- 3971™†
- 3972™†
- 3974™
- 3979™†
- 5055™
- 5056™

Item Number: 883979

- 3554™
- 3555™†
- 3556™†

OPERATIONAL OPTIONS

1427232 and 883979 require the choice of a foot switch, PLC cable, LED timer or pistol grip timer option in order to operate.

 97201 – Foot Switch	 960356 – LED Timer Includes Foot Switch 97201 and (1) LED Connection Cable	 1003327 – Pistol Grip and Timer	 8900550 – PLC Interface Cable Provides all start signal and diagnosis connection for a remote PLC.
 1102257 – Multiplexer Provides simultaneous on/off control for up to four individual 7700 HD series LEDs with either one Foot Switch or Timer unit. Requires (1) LED Connection Cable (884025) for each LED Cure Light. Order separately.		 1044301 – LED-HD Pistol Grip Battery Kit Converts 7700/7703-HD into a fully mobile tool. (Kit Includes Battery, Cap and Charger.)	

TECHNICAL SPECIFICATIONS

Item Number	1427232 – LOCTITE® 7700-HD LED Light Source	883979 – LOCTITE® Indigo 7703-HD LED Light Source
Dimensions	8.9" L x 1.4" W x 2.0" H	
Weight	0.75 lbs.	
Utilities	Universal 110-240 V; 47-263 Hz	
Light Source	High-Powered LED	
Typical Intensity*	2.5-3.0 W/cm ² at 4 mm distance (See Intensity Profile Graph above.)	
Spectral Output Range	380 to 415; Primary Peak 395 nm *	Proprietary

Additional Accessories Sold Separately

 98452 – LOCTITE® UV & Visible Light Safety Glasses (Removes all wavelengths 200 nm to 540 nm)	 1265282 – LOCTITE® Radiometer Dosimeter for Visible LED and UV Light
1403405 – LOCTITE® Dosimeter Adapter 967055 – LED Protective Tip Covers (5 pack)	

* Values denote typical expected intensities and are not a fixed specification. Exact output measurement is dependent on the brand and calibration method of the meter used and normal variation of the Light Emitting Diodes. These measurements were made with a LOCTITE® Radiometer Dosimeter, 1265282. As with all applications, testing with your specific part and adhesive is recommended.

** Henkel recommends customers test all new adhesive applications under simulated or actual end-use conditions to ensure the adhesive meets or exceeds all required product specifications. This data was generated under highly controlled laboratory conditions, and may not represent actual assembly conditions.

† Tack-free.

LOCTITE® CUREJET™ LED LIGHT SOURCES

LOCTITE® CUREJET™ 375 LED

Item Number: 1369539

Our new LOCTITE® CureJet™ LEDs are our highest power LED spot curing systems. This innovative design offers significantly wider cure area and curing intensity capability than our 7700 series spot LED devices, providing the ultimate in processing speeds. Choose the system based on the adhesive that is in use.

Features:

- A 100% on-time duty cycle.
- Unlike traditional arc lamps, 100% of LED light output is within the usable curing spectrum of LOCTITE® adhesives.
- Zero infrared emissions, reducing part heating (warping) to an absolute minimum.
- Instant On/Off – no warm-up like traditional UV systems.
- Manual or timed light exposures using an integrated control timer.
- LEDs last up to 10 times longer than typical UV bulb units, with negligible output decay during duty life.
- Internal LED diagnostics for each cycle, with visual and digital status outputs; connect via digital I/O port using optional PLC interface cable.
- Stackable with 25 mm center-to-center spacing.



Complete LOCTITE® CureJet™ Curing System

Controller	CureJet™ 375 LED	Interconnecting Cables
		
1364033	1369539	3 m 1370352 1 m 1370351

LOCTITE® Light Cure Adhesives typically cured using:**



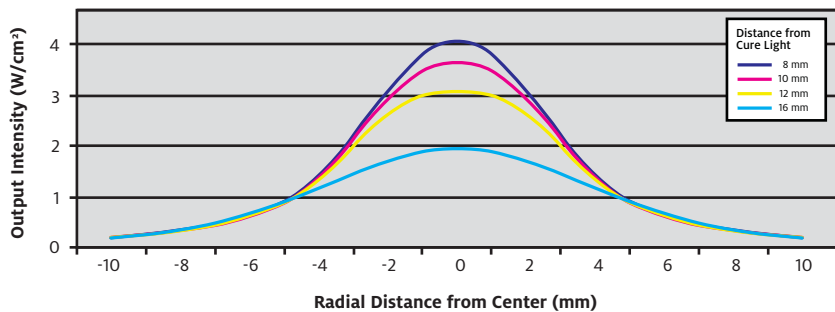

Item Number: 1369539

- | | | |
|-------------------|----------|----------|
| • All Flashcure®† | • 3492™ | • 3936™ |
| • 349™ | • 3493™ | • 3941™ |
| • 363™ | • 3494™ | • 3942™ |
| • 3108™ | • 3525™† | • 3943™ |
| • 3301™ | • 3526™† | • 3944™ |
| • 3311™ | • 3751™† | • 3971™† |
| • 3321™ | • 3761™† | • 3972™† |
| • 3336™ | • 3921™ | • 3974™ |
| • 3341™† | • 3922™ | • 3979™† |
| • 3491™ | • 3924™ | • 5055™ |
| | • 3926™ | • 5056™ |

CureJet™ 375 Intensity Profile*



TECHNICAL SPECIFICATIONS		
Item Number	1369539 – LOCTITE® CureJet™ 375 LED	1364033 – LOCTITE® LED Controller
Dimensions	25 mm W x 65 mm H x 270 mm L	260 mm W x 105 mm H x 260 mm L
Weight	0.4 kg	3.0 kg
Input Power	•	85/264 VAC; 50/60 Hz
Maximum Current	•	•
Typical Intensity*	3 W/cm ² at 8-12 mm distance (See Intensity Profile Graph.)	
Spectral Peak	Proprietary	•
Cure Light Status Outputs	Visual OK: Blue panel light on Digital OK: Dry contact closure	

Additional Accessories Sold Separately	
 98452 – LOCTITE® UV & Visible Light Safety Glasses (Removes all wavelengths 200 nm to 540 nm) [Recommended]	 1390323 – LOCTITE® Radiometer Dosimeter UV LED and UV A/B Light
 8900550 – PLC Interface Cable	1421420 – LOCTITE® CureJet™ LED Dosimeter Adapter
 1180632 – LOCTITE® Quad Controller	

* Values denote typical expected intensities and are not a fixed specification. Exact output measurement is dependent on the brand and calibration method of the meter used and normal variation of the Light Emitting Diodes. These measurements were made with a LOCTITE® Radiometer Dosimeter, 1390323. As with all applications, testing with your specific part and adhesive is recommended.

** Henkel recommends customers test all new adhesive applications under simulated or actual end-use conditions to ensure the adhesive meets or exceeds all required product specifications. This data was generated under highly controlled laboratory conditions, and may not represent actual assembly conditions.

† Tack-free.

LOCTITE® CUREJET™ LED LIGHT SOURCES

LOCTITE® CUREJET™ 405 LED

Item Number: 1369538

Our new LOCTITE® CureJet™ LEDs are our highest power LED spot curing systems. This innovative design offers significantly wider cure area and curing intensity capability than our 7700 series spot LED devices, providing the ultimate in processing speeds. Choose the system based on the adhesive that is in use.

Features:

- A 100% on-time duty cycle.
- Unlike traditional arc lamps, 100% of LED light output is within the usable curing spectrum of LOCTITE® adhesives.
- Zero infrared emissions, reducing part heating (warping) to an absolute minimum.
- Instant On/Off – no warm-up like traditional UV systems.
- Manual or timed light exposures using an integrated control timer.
- LEDs last up to 10 times longer than typical UV bulb units, with negligible output decay during duty life.
- Internal LED diagnostics for each cycle, with visual and digital status outputs; connect via digital I/O port using optional PLC interface cable.
- Stackable with 25 mm center-to-center spacing.



LOCTITE® CureJet™ shown with LED controller and cable sold separately

Complete LOCTITE® CureJet™ Curing System		
Single Controller	CureJet™ 405 LED	Interconnecting Cables
		
1364033	1369538	3 m or 1 m 1370352 or 1370351

LOCTITE® Light Cure Adhesives typically cured using:**



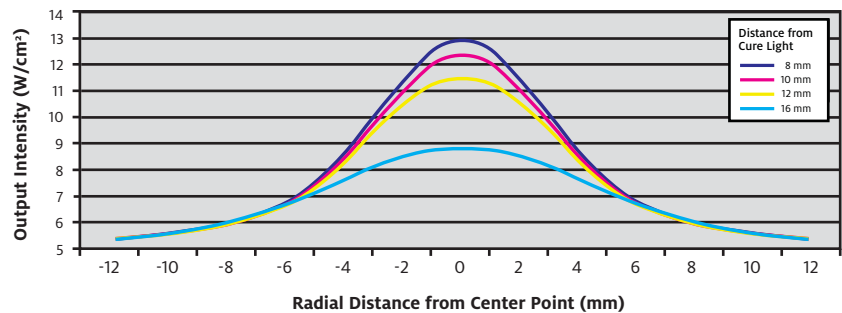

Item Number: 1369538

- | | | |
|-------------------|----------|----------|
| • All Flashcure®† | • 3555™† | • 3942™ |
| • 3301™ | • 3556™† | • 3943™ |
| • 3311™ | • 3751™† | • 3944™ |
| • 3321™ | • 3761™† | • 3971™† |
| • 3341™† | • 3921™ | • 3972™† |
| • 3494™ | • 3922™ | • 3974™ |
| • 3525™† | • 3924™ | • 3979™† |
| • 3526™ | • 3926™ | • 5055™ |
| • 3554™† | • 3936™ | • 5056™ |

CureJet™ 405 Intensity Profile*

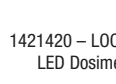

TECHNICAL SPECIFICATIONS		
Item Number	1369538 – LOCTITE® CureJet™ 405 LED	1364033 – LOCTITE® LED Controller
Dimensions	25 mm W x 65 mm H x 270 mm L	260 mm W x 105 mm H x 260 mm L
Weight	0.4 kg	3.0 kg
Input Power	•	85/264 VAC; 50/60 Hz
Maximum Current	•	•
Typical Intensity*	8.5-14 W/cm ² at 12 mm distance (See Intensity Profile Graph.)	
Spectral Peak	405 nm	•
Cure Light Status Outputs	Visual OK: Blue panel light on Digital OK: Dry contact closure	

Additional Accessories Sold Separately	
	98452 – LOCTITE® UV & Visible Light Safety Glasses (Removes all wavelengths 200 nm to 540 nm) [Recommended]
	1265282 – LOCTITE® Radiometer Dosimeter for Visible LED and UV Light
	8900550 – PLC Interface Cable
	1421420 – LOCTITE® CureJet™ LED Dosimeter Adapter
	1180632 – LOCTITE® Quad Controller

* Values denote typical expected intensities and are not a fixed specification. Exact output measurement is dependent on the brand and calibration method of the meter used and normal variation of the Light Emitting Diodes. These measurements were made with a LOCTITE® Radiometer Dosimeter, 1265282. As with all applications, testing with your specific part and adhesive is recommended.

** Henkel recommends customers test all new adhesive applications under simulated or actual end-use conditions to ensure the adhesive meets or exceeds all required product specifications. This data was generated under highly controlled laboratory conditions, and may not represent actual assembly conditions.

† Tack-free.

LOCTITE® CUREJET™ LED LIGHT SOURCES

LOCTITE® CUREJET™ INDIGO® LED

Item Number: 1369537

Our new LOCTITE® CureJet™ LEDs are our highest power LED spot curing systems. This innovative design offers significantly wider cure area and curing intensity capability than our 7700 series spot LED devices, providing the ultimate in processing speeds. Choose the system based on the adhesive that is in use.

Features:

- A 100% on-time duty cycle.
- Unlike traditional arc lamps, 100% of LED light output is within the usable curing spectrum of LOCTITE® adhesives.
- Zero infrared emissions, reducing part heating (warping) to an absolute minimum.
- Instant On/Off – no warm-up like traditional UV systems.
- Manual or timed light exposures using an integrated control timer.
- LEDs last up to 10 times longer than typical UV bulb units, with negligible output decay during duty life.
- Internal LED diagnostics for each cycle, with visual and digital status outputs; connect via digital I/O port using optional PLC interface cable.
- Stackable with 25 mm center-to-center spacing.



LOCTITE® CureJet™ shown with LED Controller and cable sold separately

Complete LOCTITE® CureJet™ Curing System

Controller	CureJet™ Indigo® LED	Interconnecting Cables
		
1364033	1369537	3 m or 1 m 1370352 or 1370351

LOCTITE® Light Cure Adhesives typically cured using:**



Item Number: 1369537

- 3553™†
- 3554™
- 3555™†
- 3556™†
- 3974™
- 3979™

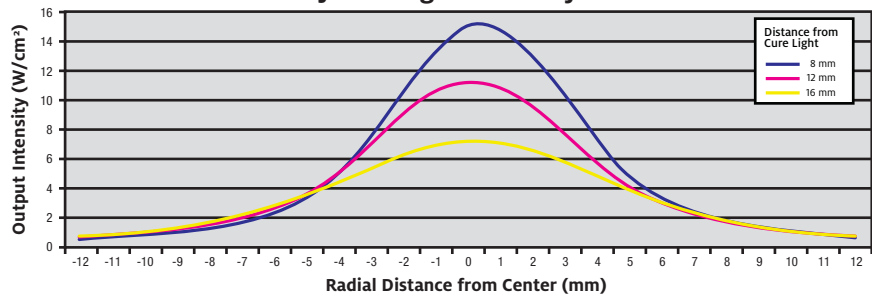
CureJet™ Indigo® Intensity Profile



TECHNICAL SPECIFICATIONS		
Item Number	1369537 – LOCTITE® CureJet™ Indigo® LED	1364033 – LOCTITE® LED Controller
Dimensions	25 mm W x 65 mm H x 270 mm L	260 mm W x 105 mm H x 260 mm L
Weight	0.4 kg	3.0 kg
Input Power	•	85/264 VAC; 50/60 Hz
Maximum Current	•	•
Typical Intensity*	9-13 W/cm ² at 12 mm distance (See Intensity Profile Graph.)	
Spectral Peak	Proprietary	•
Cure Light Status Outputs	Visual OK: Blue panel light on Digital OK: Dry contact closure	

Additional Accessories Sold Separately	
	98452 – LOCTITE® UV & Visible Light Safety Glasses (Removes all wavelengths 200 nm to 540 nm) [Recommended]
	1265282 – LOCTITE® Radiometer Dosimeter for Visible LED and UV Light
	8900550 – PLC Interface Cable
	1421420 – LOCTITE® CureJet™ LED Dosimeter Adapter

* Values denote typical expected intensities and are not a fixed specification. Exact output measurement is dependent on the brand and calibration method of the meter used and normal variation of the Light Emitting Diodes. These measurements were made with a LOCTITE® Radiometer Dosimeter, 1265282. As with all applications, testing with your specific part and adhesive is recommended.

** Henkel recommends customers test all new adhesive applications under simulated or actual end-use conditions to ensure the adhesive meets or exceeds all required product specifications. This data was generated under highly controlled laboratory conditions, and may not represent actual assembly conditions.

† Tack-free.

LOCTITE® CUREJET™ LED LIGHT SOURCES

LOCTITE® CUREJET™ QUAD CONTROLLER



Item Number: 1180632

The perfect solution when your application calls for multiple CureJet™ stations. This state-of-the-art controller is designed to provide individual programming and intensity control for one to four Curejets™ and is compatible for use with all our Curejets™, regardless of wavelength.

Features:

- Controls up to four channels of CureJet™ LED Spot Light Sources independently.
- Up to four channels can be activated with a single foot switch or each with its own foot switch.
- Each CureJet™ LED Light Source can be set to its own cure time.
- The intensity of each CureJet™ LED Light Source can be programmed from 1% to 100% intensity.
- Each channel can be programmed to turn on and off in a sequence, if desired.
- Ten different programs can be saved into memory.
- Each of the output channels is monitored and the output current is controlled to maintain a consistent intensity output of each Light Source.
- Controller monitors the temperature of each Light Source.
- Contains self-diagnosis with warning messages.
- Auto detection of different CureJet™ LED Light Sources.
- Interface I/O connectors for external automation.
- Front panel indicators show the channels that are enabled; when the LED Light Source is turned on; and if any faults or problems are evident.



TECHNICAL SPECIFICATIONS	
Item Numbers	1180632
Dimensions	9.3" H x 5.6" W x 7.1" D
Weight	10.9 lbs.
Input Voltage	88-264 VAC; 50/60 Hz.
Power Consumption	325 watts
Parts Included	(1) CureJet™ Quad Controller (1) Operator's Manual (1) AC Power Cord (1) Foot Switch – 97201
Additional Accessories Sold Separately	
 1370351 / 1370352 – Interconnecting Cables	 98452 – LOCTITE® UV & Visible Light Safety Glasses
 1369539 – LOCTITE® CureJet™ 375 LED 1369538 – LOCTITE® CureJet™ 405 LED 1369537 – LOCTITE® CureJet™ Indigo® LED	

LED Flood Systems

The LOCTITE® LED Flood Systems, consisting of a Controller, an LED Cure Array and connecting cable (each sold separately), produce a curing area of approximately 100 mm x 100 mm. These unique LED flood systems are designed for LOCTITE® UV/Visible cure adhesives. The expected life is over 20,000 hours with proper handling. Unlike traditional arc lamps, 100% of LED light output is within the usable cure spectrum of LOCTITE® adhesives. LED Cure Arrays consist of individually reflectorized LEDs creating a uniform cure area, and are available in either 375 nm, 405 nm or Indigo® nm wavelengths. The LED Cure Array wavelength is selected according to the curing requirements of the adhesive.



LOCTITE® LED FLOOD CONTROLLER

Item Number: 1359255

LOCTITE® LED FLOOD CURE, 375

Item Number: 1167582

LOCTITE® LED FLOOD CURE, 405

Item Number: 1167593

LOCTITE® LED FLOOD CURE, INDIGO®

Item Number: 1167589

This LOCTITE® Flood Array consists of 144 individually reflectorized LEDs for creating a uniform curing area at 375 nm, 405 nm or Indigo® wavelengths. The Flood Array produces a curing area of 100 mm x 100 mm. The expected life is over 20,000 hours with proper handling.

Features:

- Manual On/Off operation via the foot switch (supplied).
- Timed On/Off control via the built-in timer on the front panel, 0.1 to 99.9 seconds.
- Indicator lights on the front panel of the Controller provide visual confirmation that the LEDs are in or out of their acceptable range.
- Automated control via a customer-supplied PLC.
- End of Cycle signal and Error Relay signal available via output connector.
- Optimized to emit at the specific wavelength of 375, 405 and Indigo® Wavelength.
- Optimal curing distance: 50 mm.
- 100% duty cycle.
- Instant On/Off (no warm-up time required like traditional arc lamp systems).
- Stackable on 100 mm center-to-center spacing to create a limitless blanket of light.
- Energy-efficient LEDs produce little wasted energy.
- Cold Light: LEDs produce zero infrared emissions, reducing part heating and warping.
- Lasts up to 10 times longer than traditional arc lamps, with negligible output decay during duty cycle.



LEFT: LOCTITE® LED Flood Controller
BELOW: LOCTITE® LED Flood Cure



Complete LOCTITE® LED Flood Cure System

Controller



1359255

LED Flood Cure



1167582, 1167593
and 1167589

Connecting Cable



1333333

TECHNICAL SPECIFICATIONS

Item Number	1359255 – LOCTITE® LED Flood Controller		
Dimensions	14.4" L (365 mm) x 12.2" W (310 mm) x 5.3" H (135 mm)		
Weight	7.7 lbs. (3.5 kg)		
Input Power	90-260 V.A.C., 47-63 Hz.		
Power Consumption	Approximately 350 watts		
Parts Included	(1) Foot Switch (1) Operating Manual (1) AC Power Cord		
Item Number	1167582 – LOCTITE® LED Flood Cure, 375	1167593 – LOCTITE® LED Flood Cure, 405	1167589 – LOCTITE® LED Flood Cure, Indigo®
Dimensions	6" L (152 mm) x 4" W (100 mm) x 4.5" H (114 mm)		
Weight	Approx. 4 lbs. (1.8 kg)		
Compliance	ROHS		

LOCTITE® Light Cure Adhesives typically cured using:*

Item Number: 1167582





- All Flashcure®†
- 3301™
- 3311™
- 3321™
- 3336™
- 3341™†
- 3494™
- 3525™†
- 3526™
- 3751™
- 3761™
- 3921™
- 3922™
- 3924™
- 3926™
- 3936™
- 3941™
- 3942™
- 3943™
- 3944™
- 3971™†
- 3972™†
- 3974™
- 3979™
- 5055™
- 5056™
- 5240™

Item Number: 1167593

- 3301™
- 3311™
- 3321™
- 3341™†
- 3494™
- 3525™†
- 3526™
- 3554™†
- 3555™†
- 3556™†
- 3751™
- 3761™
- 3921™
- 3922™
- 3924™
- 3926™
- 3936™
- 3941™
- 3942™
- 3943™
- 3944™
- 3971™†
- 3972™†
- 3974™
- 3979™
- 5055™
- 5056™
- 5240™

Item Number: 1167589

- 3554™
- 3555™
- 3556™

Additional Accessories Sold Separately		
Radiometer	Use With	Requires
 <p>1390323 – LOCTITE® Radiometer Dosimeter for UV LED and UV A/B Light</p>	 <p>1167582 – LOCTITE® LED Flood Cure, 375</p>	N/A
 <p>1265282 – LOCTITE® Radiometer Dosimeter for Visible LED and UV Light</p>	 <p>1167593-(405) / 1167589-(Indigo) – LOCTITE® LED Flood Cure</p>	1403403 – Adapter/Filter for Visible Arc Lamps.

* Henkel recommends customers test all new adhesive applications under simulated or actual end-use conditions to ensure the adhesive meets or exceeds all required product specifications. This data was generated under highly controlled laboratory conditions, and may not represent actual assembly conditions.

†Tack-free.

LOCTITE® SINGLE LINE ARRAY LED SYSTEM

LOCTITE® SINGLE LINE ARRAY LED – CONTROLLER

Item Number: 1447728

LOCTITE® SINGLE LINE ARRAY LED – 365

Item Number: 1449337

LOCTITE® SINGLE LINE ARRAY LED – 405

Item Number: 1449336

Our LOCTITE® LED Line Cure system provides high power adhesive curing control for high speed product lines while ensuring minimal space intrusion into the process. Multiple LED Arrays can be stacked tightly together to accommodate your process. The system also includes a small upright controller for up to four LED heads, providing independent time for each LED Array that is installed.

Features:

- Highly focused LED Array provides effective curing intensity across a 5 mm x 80 mm cross-sectional area.
- Super long life, 20,000-hour LEDs are instant On/Off with virtually no part heating.
- Optional Cure Booster Lens Assembly available to increase intensity up to 2x.
- Optimize cure time for up to four individual Arrays with just one controller.
- LED temperature and voltage monitoring alarms are displayed visually on the controller or can be integrated into PLC interface.
- Stackable side-by-side to accommodate process requirements.
- Can be run with a 100% duty cycle.



Complete LOCTITE® LED Line Cure System

Quad Controller



1447728

LED Line Cure



1449337 or 1449336

Connection Cable







2.1 m
1483245

LOCTITE® Light Cure Adhesives typically cured using:*

Item Number: 1449337

- | | | | |
|-------------------|----------|----------|----------|
| • All Flashcure®† | • 3341™ | • 3921™† | • 3944™ |
| • 349™ | • 3491™ | • 3922™ | • 3971™† |
| • 349™ | • 3492™ | • 3924™ | • 3972™† |
| • 363™ | • 3493™ | • 3926™ | • 3974™ |
| • 3108™ | • 3494™ | • 3936™ | • 3979™ |
| • 3301™ | • 3526™ | • 3941™ | • 5055™ |
| • 3311™ | • 3751™† | • 3942™ | • 5056™ |
| • 3321™ | • 3761™† | • 3943™ | • 5240™ |
| • 3336™ | | | |

Additional Accessories Sold Separately		
Radiometer	Use With	Requires
 1390323 – LOCTITE® Radiometer Dosimeter UV LED and UV A/B Light	 1449337 – LOCTITE® Single Line Array LED – 365	N/A
 1265282 – LOCTITE® Radiometer Dosimeter for Visible LED and UUV Light	 1449336 – LOCTITE® Single Line Array LED – 405	1403403 – Adapter/Filter for Visible Arc Lamps.
376746 – Protection Gloves, white 1500901 – Lens System to boost the intensity		
For proper eye protection, use LOCTITE® brand Safety Glasses.		98452 – UV & Visible Light Safety Glasses, Orange

TECHNICAL SPECIFICATIONS		
Item Number	1447728 – LOCTITE® Single Line Array LED – Controller	
Dimensions	5.9" W x 8.8" H x 10.2" D	
Weight	5.25 lbs.	
Input Power	90-260 V AC, 47-63 Hz	
Power Consumption	150 watts	
Recommended Operating Temperature	+50°F to +104°F	
Item Number	1449337 – LOCTITE® Single Line Array LED – 365	1449336 – LOCTITE® Single Line Array LED – 405
Dimensions	3.15" L x 1.49" H x 0.9" W	
Weight	0.6 lbs.	
Typical Intensity	600 mw/cm ² @ 20 mm distance	400 mw/cm ² @ 20 mm distance
Optimum Cure Distance	5-20mm	
Curing Area	5 mm x 80 mm	
Recommended Operating Temperature	+50°F to +104°F	

* Henkel recommends customers test all new adhesive applications under simulated or actual end-use conditions to ensure the adhesive meets or exceeds all required product specifications. This data was generated under highly controlled laboratory conditions, and may not represent actual assembly conditions.

† Tack-free.

Wand Systems

LOCTITE® EQ CL10 SINGLE LED CONTROLLER

Item Numbers: 1514636

LOCTITE® EQ CL10 QUAD LED CONTROLLER

Item Numbers: 1514634

LOCTITE® EQ CL10 6 MM LED HEAD 2.7 M

Item Numbers: 1538499 – 365 nm
1746633 – 405 nm

The LOCTITE® EQ CL10 LED System is a wand style LED spot light source with heads that emit light at 365 nm. It is ideal for both manual work stations as well as integration into automated production lines. The EQ CL10 can be operated in a continuous light output mode or programmed output mode with programmable light output intensity and time. Unlike traditional mercury arc wand systems the targeted wavelength of the EQ CL10 LEDs prevents thermal damage or harmful effects to objects being illuminated. Its low power consumption makes it an energy-saving and environmentally friendly light source compared to mercury arc lamps and, unlike mercury arc systems, does not require routine light guides or lamp replacements.

Features:

LOCTITE® EQ CL10 Single LED Controller

- Instant On/Off capabilities; no warm-up time required as compared to mercury arc lamp UV Wand systems.
- LED head can be programmed for UV intensity and exposure time.
- Temperature feedback prevents LED head overheating.
- Over 20,000 working hours.
- No IR emission resulting in low temperature curing. Will not damage parts due to heat emission.
- Up to 90% energy savings, compared with mercury arc lamps.
- Small LED head for hand held or fixed fixture applications.
- Foot switch actuated or PLC remote control.
- Low maintenance cost.

LOCTITE® EQ CL10 Quad LED Controller

- Instant On/Off capabilities; no warm-up time required as compared to mercury arc lamp UV Wand systems.
- Up to four (4) heads that can be operated independently or simultaneously in either continuous output mode or in an up to 10-step program mode with independent time and intensity settings for each head.
- Cycling can be initiated with the Start/Stop button on the front panel; a foot switch (included); or via a PLC connection with an external start signal.
- Each LED head can be programmed independently with an up to 10-step program of light intensity and exposure time.
- Provides five programming modes (constant intensity; pulsed; step; optical; manual).
- Each channel is adjustable and can be controlled separately.
- Temperature feedback prevents LED heads overheating.
- Over 20,000 working hours.
- No IR emission resulting in low temperature curing. Will not damage parts due to heat emission.
- Up to 90% energy savings, compared with mercury arc lamps.
- Small LED head for handheld or fixed fixture applications.
- Low maintenance cost.

For proper eye protection, use LOCTITE® brand Safety Glasses.



98452 – UV & Visible Light Safety Glasses, Orange



LOCTITE® EQ CL10 Single LED Controller

LOCTITE® EQ CL10 Quad LED Controller

Complete LOCTITE® EQ CL10 Curing System

Single LED Controller



1514636

Quad LED Controller



1514634

LED Heads (1-4)



1538499 – 365 nm
1746633 – 405 nm

TECHNICAL SPECIFICATIONS

Item Numbers		1514636	1514634
Modes	Timer	Intensity: 0%–100%, Timer: 0.1–999.9 sec.	Intensity: 0%–100%, Time: 0.1–999.9 sec.
	Manual	Intensity: 0%–100%, Timer: Manual Control	Intensity: 0%–100%, Time: Manual control.
	Step	—	10 steps, each step can define intensity and time independently.
Power Supply		AC 100-240V 50/60 Hz	100-220 VAC; 50/60 Hz Max. 1.5 amps
Power Consumption		15 Watts	30 Watts
Cooling Method		Natural Cooling	
Temperature Range		Operating: +5°C to 40°C, Storage: -15°C to +65°C	
Weight		0.6 Kg	2 Kg
Wavelength		365 nm or 405 nm	
Replacement Parts			
1538496 – EQ CL10 365 nm; 6mm LED Lens		1750074 – EQ CL10 405 nm; 6mm LED Lens	

Additional Accessories Sold Separately



97201 – Foot Switch

Radiometer	Use With	Requires
<p>1390323 – LOCTITE® Radiometer Dosimeter for UV LED and UV A/B Light</p>	<p>1538499 – LOCTITE® EQ CL10 6 mm LED Head 2.7 m 365 nm</p>	<p>1403402 – Adapter for EQ CL 10 LED heads (1538499 – 365 nm) (1746633 – 405 nm)</p>
<p>1265282 – LOCTITE® Radiometer Dosimeter for Visible LED and UV Light</p>	<p>1746633 – LOCTITE® EQ CL10 6 mm LED Head 2.7 m 405 nm</p>	<p>1403402 – Adapter for EQ CL 10 LED heads (1538499 – 365 nm) (1746633 – 405 nm)</p>

LOCTITE® EQ CL15 UV WAND SYSTEMS

Item Numbers: 1661548

The LOCTITE® EQ CL15 Wand Systems utilize a 100 watt high-pressure mercury arc lamp with a universal power supply and a liquid-filled light wand. They can be operated manually or in the timed mode and are capable of interfacing with a PLC controlled circuit.

Features:

- Powerful mercury arc lamp provides up to 15W/cm².*
- Manual, timed or cycle shutter operation.
- Complete cycle control – settable parameters include:
 - UV exposure time, (shutter open).
 - Dwell time, (shutter closed).
 - Number of cycles, (continuous cycling).
- “Lamp On” is indicated by relay contact output.
- Can be operated from an external PLC.
- Small footprint and lightweight, (7½ lbs.).
- Shutter is operated by a reliable rotary solenoid.
- Lamp is disabled if the enclosure lid is removed.
- Light guide interlock safety switch prevents accidental UV exposure if the light guide is not installed Internal dichroic mirror minimizes the transmission of heat caused by “waste energy,” while allowing critical UV light to pass.
- Provides excellent depth-of-cure capabilities due to its high UV output.
- Ideal for interface with automated assembly lines via the dry-contact closure 9-pin connector located on rear project.



LIGHT GUIDE OPTIONS – UV WANDS

Description	Dimensions	Item Numbers			
		Single Pole	2 Pole	3 Pole	4 Pole
Standard§	3 mm x 1000 mm	N/A†	983684	98596	98597
	5 mm x 1000 mm	983677	N/A†	N/A†	N/A†
	5 mm x 1500 mm	951681	N/A†	N/A†	N/A†

§ Available enhanced UVC wands require optional filter kit to optimize tack-free surface cure. (Call for details).

† Multi-pole guides are only available with 3 mm diameter poles.

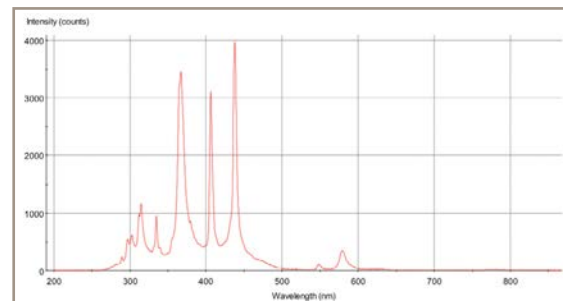

Typical Light Guide Cure Areas

983677: ¼" to ½" diameter

983684: ⅛" to ¼" diameter

951681: ¼" to ½" diameter

For proper eye protection, use LOCTITE® brand Safety Glasses.



98452 – UV & Visible Light Safety Glasses, Orange

TECHNICAL SPECIFICATIONS

Item Numbers		1661548
Power Supply		90-264 VAC; 50-60 Hz
Warm-Up Time		90 seconds
Dimensions		12.5" W x 9.75" D x 5.5" H
Weight		7 lbs.
Optimized Spectral Output Range		UVA, B, C
UV Output Characteristics	Typical**	Up to 15 W/cm ² (using 5 mm x 1,000 mm light guide)*
	UV Spectral Range	250 to 450 nm
Parts Included		(1) LOCTITE® EQ CL15 UV Wand System (1) Ultraviolet Protection Glasses (1) Line Cord (1) UV Lamp (1) Foot Pedal (1) Manual
Replacement Parts		1664246 – EQ CL15 Replacement Lamp

Additional Accessories Sold Separately



1406024 – 7020 UV Spot Radiometer

* Output with a new lamp installed and measured with a LOCTITE® 7020 UV Spot Radiometer, item #1406024

** Denoted values are typical expected intensity and are not a fixed specification. Exact output measurement is dependent on the brand and calibration method of the meter used plus normal variation of arc lamps. Condition and straightness of light guide will also affect output. Comparisons of different light sources should only be made using a common meter. Do not evaluate by published data.

Cure Chambers & Flood Systems

LOCTITE® brand chamber and flood systems are modular low- and medium-intensity ultraviolet and high-intensity visible light-emitting units designed for the batch curing of light curing adhesives and coatings. Selection of a LOCTITE® brand chamber and flood system is based on the required intensity of light and cure area.



LOCTITE® CURE CHAMBERS

LOCTITE® 7401 UV CHAMBER

Item Number: 98039

The LOCTITE® 7401 UV Chamber provides a reliable and economical design for UV curing and is well-suited for most production operations. Excellent for use in confined bond line applications, this medium-intensity light source can be used for adhesive applications where high-intensity output is not necessary.

Features:



- Contains a 4 in., 400 watt metal halide bulb.
- Designed to emit in the UVA region.
- Curing area of 8 in. x 8 in., and a maximum part height of 4 in.
- Operator's hands have no direct exposure to UV energy.
- Expected UV lamp life of 1,000 hours with proper handling and maintenance.
- Convenient pull-out drawer to process parts.
- Viewing window to observe assemblies in process.
- The work surface is covered by a special silicone rubber pad to resist UV deterioration and chemical attack.

Theory of Operation

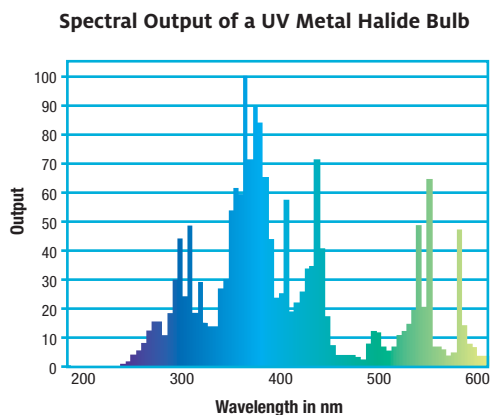
The unit is operated by simply placing the assembly into the cure drawer, closing the drawer, and allowing exposure for the desired time. A viewing window allows monitoring of the curing process.



TECHNICAL SPECIFICATIONS	
Utilities	120 VAC; 8 amps; 60 Hz
Lamp Type, (Visible and UV enhanced)	400 watt Metal Halide
Dimensions	11.5" H x 10.75" W x 20.1" D
Weight	39 lbs.
Parts Included	(1) 7401 UV Chamber (1) Pair Cotton Gloves (1) UV Protective Eyewear (1) Power Cord (1) Manual
Replacement Parts	97246 – LOCTITE® UV Lamp - 400 watt Metal Halide

Additional Accessories Sold Separately		
Radiometer	Use With	Requires
 1390323 – LOCTITE® Radiometer Dosimeter for UV LED and UV A/B Light	97246 – LOCTITE® UV Lamp - 400 watt Metal Halide	N/A
 1265282 – LOCTITE® Radiometer Dosimeter for Visible LED and UVV Light	983050* – LOCTITE® Visible Light Enhanced Metal Halide Bulb	1403403 – Adapter/Filter for Visible Arc Lamps

* Optional replacement bulb.

LOCTITE® FLOOD SYSTEMS

LOCTITE® 7411-S UV FLOOD SYSTEM

Item Number: 98413

The LOCTITE® 7411-S UV Flood System is designed for use in a wide range of bonding, potting, tacking and sealing applications. Because of its reliability and simplicity, it is well-suited for most production operations. The LOCTITE® ZETA® 7411-S can accept multiple part sizes. An optional timed control shutter (as displayed) or visible enhanced metal halide lamp are also available.

Features:

- Contains a 4 in., 400 watt metal halide bulb*.
- Optimized to emit in the UVA region.
- Typical curing area of 8 in. x 8 in.
- Expected UV lamp life of 1,000 hours with proper handling and maintenance.
- Power supply can be separated from the lamp base assembly.
- Lamp height is adjustable to a maximum height of 11¾ in. from pad.
- Contains a glass filter to reduce the short and medium wavelength lamp emissions.
- The work surface is covered by a special silicone rubber pad to resist UV deterioration and chemical attack.



Shown with 98420 – Optional Shutter Assembly

Theory of Operation

The operator places the assembly to be bonded into the cure area, allows the assembly to be exposed for the proper time, and manually removes the cured assembly. In addition, the light source can be pulled from the power supply and mounted over a conveyor belt for a more automated use of the equipment.

Spectral Output of a UV Metal Halide Bulb

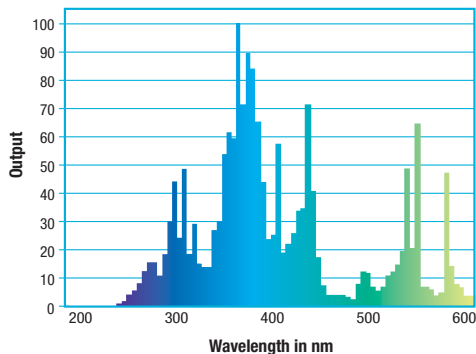

For proper eye protection, use LOCTITE® brand Safety Glasses.



98452 – UV & Visible Light Safety Glasses, Orange



TECHNICAL SPECIFICATIONS

Utilities	120 VAC; 8 amps; 60 Hz
Lamp Type, (Visible and UV enhanced)	400 watt Metal Halide
Dimensions	27.0" H x 12.7" W x 14.0" D
Weight	37 lbs.
Parts Included	(1) Reusable Shipping Box Foam Packaging (1) Height Adjustment for Reflector Housing (1) Reflector Housing with Flexible UV Curtain Shield Attached (1) UV Protective Eyewear (1) Cotton Gloves (1) UV Power Supply (1) Power Cord (1) Manual
Replacement Parts	984967 – LOCTITE® Replacement Silicone Work Surface 988159 – LOCTITE® Replacement Filter Glass 988173 – LOCTITE® Replacement Light Blocking Curtain 97246 – LOCTITE® UV Lamp - 400 watt Metal Halide 983050* – LOCTITE® Visible Light Enhanced Metal Halide Bulb

Additional Accessories Sold Separately



98420 – LOCTITE® Time Controlled Shutter

Radiometer	Use With	Requires
 1390323 – LOCTITE® Radiometer Dosimeter for UV LED and UV A/B Light	97246 – LOCTITE® UV Lamp - 400 watt Metal Halide	N/A
 1265282 – LOCTITE® Radiometer Dosimeter for Visible LED and UV Light	983050* – LOCTITE® Visible Light Enhanced Metal Halide Bulb	1403403 – Adapter/Filter for Visible Arc Lamps

* Optional replacement bulb.

LOCTITE® FOCUSED UV FLOOD CURING SYSTEM

Item Number: 1113131

The LOCTITE® Focused UV Flood Curing System is designed for use in a wide range of bonding, potting, tacking and sealing applications. Because of its reliability and simplicity, it is well-suited for most production operations. The system irradiates medium power, long wave and ultraviolet light, focused over a 2 in. x 4 in. work area. All operational components are conveniently contained in one portable unit. The comfortable handle provides for easy handheld use or the unit can be mounted, making use of threaded mounting holes on the top side. An optional headrest assembly is also available to keep the unit off a benchtop surface.

Features:

- Focused UV light source with up to three times the intensity of our 7411-S unit over a 2 in. x 4 in. work area.
- Optimized to emit in the UVA region.
- Complete curing system in one portable assembly.
- Includes Standby Mode to increase bulb life and temperature impact of the work area.
- Constant lamp power regulation, with convenient 120 VAC line operation.
- Optional Headrest Assembly to keep off benchtop surface when not in use.



Theory of Operation

The unit can be either handheld or mounted for the specific curing application. After warm-up, the part to be cured is placed under the lamp for the predetermined required amount of exposure time. To minimize heat buildup and extend bulb life, the unit can be switched into a standby mode.



Shown with optional Headrest Assembly

TECHNICAL SPECIFICATIONS	
Utilities	120 VAC, 60 Hz single phase
Lamp Type, (Visible and UV enhanced)	400 watt Metal Halide
Dimensions	7.6" L x 4.5" W x 8.1" H
Weight	4.5 lbs.
Parts Included	(1) Head Lamp Assembly (1) Power Cord (1) UV Protective Eyewear (1) Pair Cotton Gloves (1) Operator's Manual (1) Reusable Shipping Box and Foam Packaging
Replacement Parts	97246 – LOCTITE® UV Lamp - 400 watt Metal Halide

Additional Accessories Sold Separately		
Radiometer	Use With	Requires
 1390323 – LOCTITE® Radiometer Dosimeter for UV LED and UV A/B Light	97246 – LOCTITE® UV Lamp - 400 watt Metal Halide	N/A
 1265282 – LOCTITE® Radiometer Dosimeter for Visible LED and UV Light	983050* – LOCTITE® Visible Light Enhanced Metal Halide Bulb	1403403 – Adapter/Filter for Visible Arc Lamps

* Optional replacement bulb.

For proper eye protection, use LOCTITE® brand Safety Glasses.



98452 – UV & Visible Light Safety Glasses, Orange

Cure Conveyors

LOCTITE® brand cure conveyors are used for continuous or batch processing of assemblies. Each conveyor has a unique set of features designed to meet the challenges associated with benchtop curing of light curing adhesives and coatings. Selection of a LOCTITE® brand cure conveyor is based on the part size and the required lamp for optimum cure.



LOCTITE® 7415 UV BENCHTOP CONVEYOR

Item Number: 98003

The LOCTITE® 7415 UV Benchtop Conveyor offers variable speed adjustment for low- to medium-volume production, and is designed for use with an electrodeless bulb and a parabolic reflector to create a uniform cure area. The lamp assembly, conveyor and power supply are ordered separately. The system can be integrated into an automatic or semiautomatic production line for cure-on-demand assembly.



Features:

- Conveyor speeds from 3.3 to 23 ft. per minute or 0.3 to 7.2 ft. per minute.
- Typical curing area width of 6 in.
- Lamp orientation and height are adjustable for variable cure focal points.
- Integrated modular blower for lamp cooling.



TECHNICAL SPECIFICATIONS	
Conveyor Utilities	117 VAC single phase, 1 amp, 50-60 Hz or can be configured for 230 VAC single phase
98004* Power Supply Utilities	208 VAC single phase; 18 amps; 50/60 Hz
98005* Power Supply Utilities	240 VAC single phase; 18 amps; 50/60 Hz
Maximum Part Size	7.5" W x 3" H
Conveyor Size	27.4" H x 42" W x 20" D
Conveyor Weight	85 lbs.
Power Supply Size	8" H x 19.9" W x 23" D
Useful Cure Area	6" x 6"
Optimized Spectral Output Range	UVA, B, C*
Parts Included	(1) LOCTITE® 7415 UV Benchtop Conveyor* (1) Ultraviolet Protection Glasses (1) Manual

* The lamp assembly is sold separately; see the Light Sources section on pages 96-97 for more details.

Additional Accessories Sold Separately		
983464 – LOCTITE® Sight Shield, Snap In, Box End Style		983462 – LOCTITE® Exhaust Plenum
Radiometer	Use With	Requires
 1390323 – LOCTITE® Radiometer Dosimeter for UV LED and UV A/B Light	983469 – LOCTITE® D Bulb - 300 W/in. 983470 – LOCTITE® H Bulb - 300 W/in.	N/A
 1265282 – LOCTITE® Radiometer Dosimeter for Visible LED and UVV Light	983471 – LOCTITE® V Bulb - 300 W/in.	1403403 – Adapter/Filter for Visible Arc Lamps

LOCTITE® UV CURING CONVEYOR

Item Number: 1241543

The LOCTITE® UV Curing Conveyor is a benchtop, ultraviolet curing conveyor used to cure light curing adhesives and coatings. This conveyor has a medium-pressure mercury arc lamp that produces high-intensity ultraviolet energy in the UVA, UVB and UVC spectral region. This system can be integrated into an automatic or semiautomatic production line for cure-on-demand assembly.

Features:

- A 6 in., medium-pressure mercury arc lamp.
- Lamp height can be adjusted to vary intensity.
- Variable bulb wattage: 150 or 300 watts per inch to accommodate heat-sensitive applications.
- Optimized to emit in the UVA, UVB and UVC regions.
- Typical curing width 6% in. with 6 in. maximum part height.
- Expected UV bulb life of 1,000 hours with proper handling and maintenance.
- Variable conveyor speed up to 30 ft. per minute.
- Vacuum hold-down for lightweight substrates.



Spectral Output of a Medium-Pressure Mercury Arc Bulb

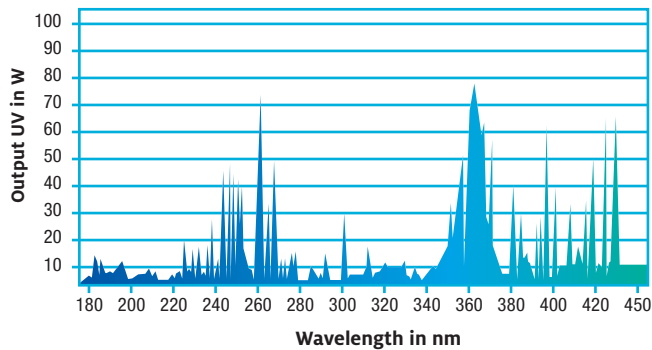

TECHNICAL SPECIFICATIONS

Input Power Required	120 VAC; 1 phase; 50/60 Hz; fused for 21 amps
Power Consumption at 300 W/in. Setting	Approximately 2,200 watts
Belt	304 stainless steel wire
Maximum Part Weight	3 lbs.
Belt Speed Range (minimum to maximum)	0 to 30 ft./minute
Lamp	1,800 watt Medium Pressure Mercury Arc Lamp
Maximum Part Cross Section	6" H x 6.625" W
Dimensions	34" H x 54" W x 30" D
Weight	80 lbs.
Parts Included	(1) LOCTITE® UV Curing Conveyor (1) Ultraviolet Lamp (1) Ultraviolet Protection Glasses (1) Pair of Cotton Gloves (1) Manual
Replacement Bulb	983091 – Replacement 6" UV Bulb – 300 W/in.

Additional Accessories Sold Separately



1390323 – LOCTITE® Radiometer Dosimeter
UV LED and UV A/B Light

High Intensity Light Sources

Our light sources and power supplies provide high-intensity ultraviolet light for curing light cure adhesives and coatings. These units are designed to be integrated into a LOCTITE® brand conveyor system, or used when the end user provides the conveyor and shielding requirements. Selection of a light source and power supply is based on the bulb type, electrical requirements and the desired part movement.

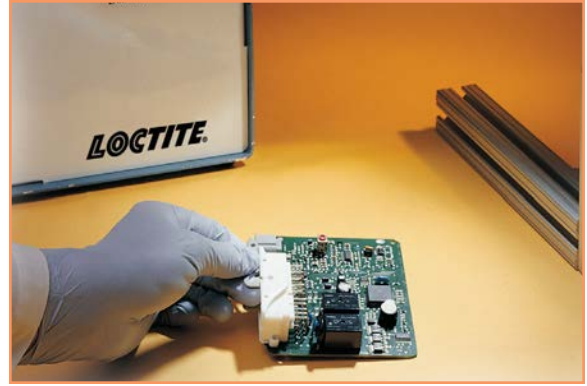

LOCTITE® ELECTRODELESS LAMP ASSEMBLY AND POWER SUPPLY

Item Numbers: 98004 – 208 VAC single phase, 18 amps, 50/60 Hz

Item Numbers: 98005 – 240 VAC single phase, 18 amps, 50/60 Hz

The LOCTITE® Electrodeless Lamp Assembly comes equipped with a long life 6 in. "H" bulb. The light source is compatible with "D," "V," "H" and "H+" bulbs to tailor the spectral output of the light to the application. Selection of the 98004 or 98005 is based on the electrical capabilities available to the end user. The LOCTITE® Electrodeless Lamp Assembly is typically used with the LOCTITE® 7415 UV Benchtop Conveyor.

Features:



- Designed for use with the LOCTITE® 7415 UV Benchtop Conveyor.
- Electrodeless bulb technology provides high intensity output.
- The system is shipped standard with an "H" bulb, but will accept "D," "V" or "H+" bulbs to fine-tune lamp spectral output.
- Expected UV bulb life of 5,000 hours of the "H" bulb, with proper handling and maintenance.
- High UV output with low IR output results in less heat to the substrate.

Theory of Operation

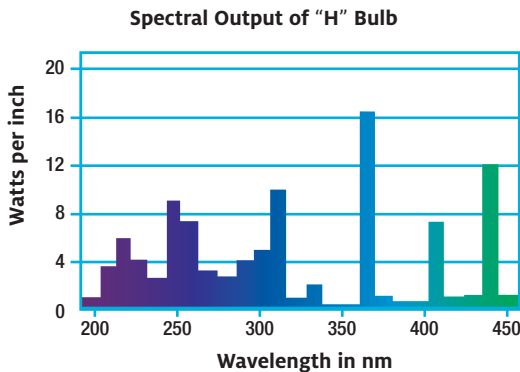
An operator will assemble parts with a light curing adhesive or coating and manually or automatically place the part under the lamp for cure. Shielding is obtained through the use of this assembly with a LOCTITE® 7415 Benchtop Conveyor. If used elsewhere, shielding must be provided by the customer.



TECHNICAL SPECIFICATIONS		
Power Supply	98004	208 VAC single phase; 18 amps; 50/60 Hz
	98005	240 VAC single phase; 18 amps; 50/60 Hz
Lamp	Fusion H Bulb – 300 W/in.	
Dimensions	19.9" H x 6.6" W x 10.3" D	
Parts Included	(1) Fusion Lamp Assembly and Power Supply (1) Manual	
Replacement Bulb	983470 – Fusion H Bulb – 300 W/in.	

Additional Accessories Sold Separately		
Radiometer	Use With	Requires
 1390323 – LOCTITE® Radiometer Dosimeter for UV LED and UV A/B Light	983469 – LOCTITE® D Bulb - 300 W/in. 983470 – LOCTITE® H Bulb - 300 W/in.	N/A
 1265282 – LOCTITE® Radiometer Dosimeter for Visible LED and UVV Light	983471 – LOCTITE® V Bulb - 300 W/in.	1403403 – Adapter/Filter for Visible Arc Lamps

LOCTITE® HIGH INTENSITY ULTRAVIOLET SOURCES

Item Numbers: 980160

The LOCTITE® High Intensity Ultraviolet Sources are designed for a wide range of applications using ultraviolet curing adhesives and coatings. With the proper shielding, cooling and venting (not included with this product), this light source can be integrated into both prototype and production applications. This unit is designed specifically for the users who want to integrate their own shielding, cooling, venting and mounting systems into a production line.

Features:

- Contains a 5 in., 300 watts/inch medium-pressure mercury vapor bulb – Item Number 980161.
- Variable bulb wattage: 200 or 300 watts/in.
- Designed to emit in the UVA and UVB regions.
- Typical curing area of 4.5 in. x 6 in.
- Expected UV bulb life of 1,000 hours with proper handling and maintenance.

Theory of Operation

To assemble a component with a UV curing adhesive or coating, place and remove the part manually or automatically under the light source. Customers will provide their own mounting, shielding, cooling and venting for this unit.

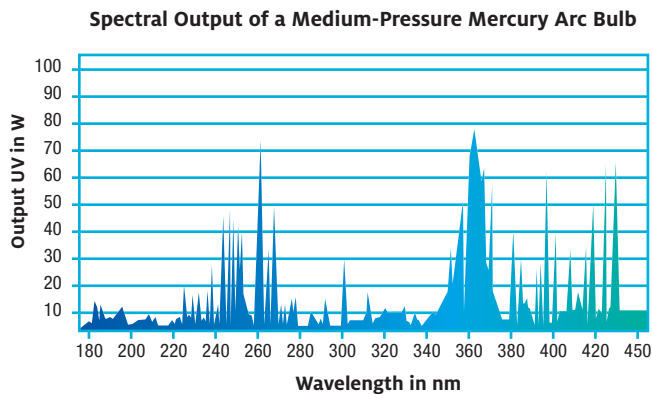

For proper eye protection, use LOCTITE® brand Safety Glasses.



98452 – UV & Visible Light Safety Glasses, Orange



TECHNICAL SPECIFICATIONS	
Power Supply	115 VAC; 60 Hz; 15 amp
Power Consumption	2,000 Watts
Lamp	300 watt Medium Pressure Mercury Arc Lamp
Lamp Unit Size	15.18" L x 8.7" W x 7.4" H
Power Supply Size	15.0" L x 14.7" W x 12.1" H
Lamp Unit Weight	9 lbs.
Power Supply Weight	45 lbs.
Parts Included	(1) High-Intensity UV Source (1) Ultraviolet Protection Glasses (1) Manual
Replacement Bulb	980161 – Replacement 5" UV Bulb – 300 W/in.

Additional Accessories Sold Separately	
	1390323 – LOCTITE® Radiometer Dosimeter for UV LED and UV A/B Light

AssureCure® System

Light cure adhesive technology was introduced more than 20 years ago and has gained use in a wide range of assembly and coating applications.

Although significant improvements have been introduced over this time – such as faster cure times, lower light intensity requirements, and enhanced physical and chemical resistance characteristics – the ability to verify the degree of cure has been the greatest challenge.

Henkel Corporation has introduced a revolutionary new technology designed to quantitatively and cost-effectively assess the degree of cure of light cure adhesives. A simple in-line process, the LOCTITE® AssureCure® System includes new adhesive technology, fiber optic light sources, a light detector unit, and software that ties into the users' PC or PLC.

LOCTITE® ASSURECURE® SYSTEM

Item Numbers: See Chart

The LOCTITE® AssureCure® Monitoring System is designed to detect, measure, analyze, record and provide a degree of cure metric relative to the transition of specially formulated adhesives from a liquid to a solid (cured).

Features:

Quantifiable Degree of Cure of Light Cure Adhesives

- Confirm cure
- Reduce in-process QC testing
- Reduce scrapped parts and resources
- Increase production speeds

AssureCure® Small System Size

- Easy fit into existing production lines
- Minimal space required

Connection to Existing PLCs

- Allows for go/no-go decision
- Data recording

ISO™ 10993 Biocompatible Adhesives

- Suitable for disposable medical device assembly

Fluorescent in Uncured and Cured State

- Confirmation of adhesive presence and location parts

Verification of System Accuracy:

The data from the AssureCure® system has been compared directly to proven off-line methods to confirm when an adhesive has cured, including physical and analytical testing. The comparative results show exceptional correlation between the AssureCure® output and pull-strength testing, as well as with infrared analysis of the adhesive.

Adhesives:

AssureCure® light cure adhesives can be provided in a range of viscosities, physical properties and package configurations.

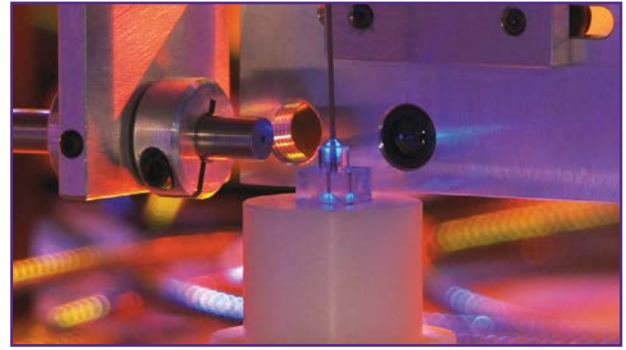

PRODUCT	Item Number	Function
Interface Module with LED Light Source	1470727	Measures, analyzes and records multiple optical measurements
Light Source Fiber	Single - 1470724	Transmits light to adhesive bond line (up to 4 points)
	Double - 1470728	
	Triple - 1470729	
	Quad - 1470730	
Detector Fiber	1470771	Directs adhesive's optical response to Optic Module
Optic Module	1471134	Analyzes multiple optical measurements
Optic Processor	1470726	Accepts input from multiple optic modules and provides output to PC/PLC

Additional Accessories Sold Separately		
Radiometer	Use With	Requires
 1265282 – LOCTITE® Radiometer Dosimeter for Visible LED and UVW Light	AssureCure® Light Sources:	1527709 – Adapter for AssureCure® Light Sources (1470724, 1470728, 1470729, 1470730)
	Single - 1470724	
	Double - 1470728	
	Triple - 1470729	
	Quad - 1470730	

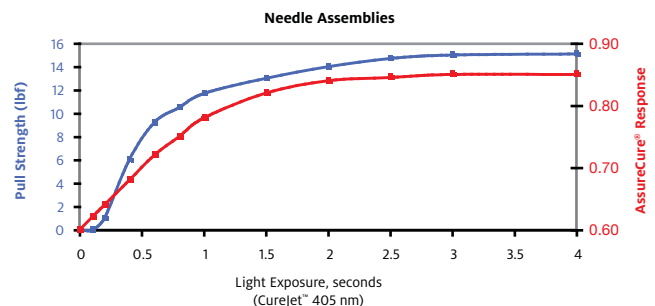

Light Meters

Henkel offers several light meters designed to consistently measure the output of our UV and visible light cure equipment.

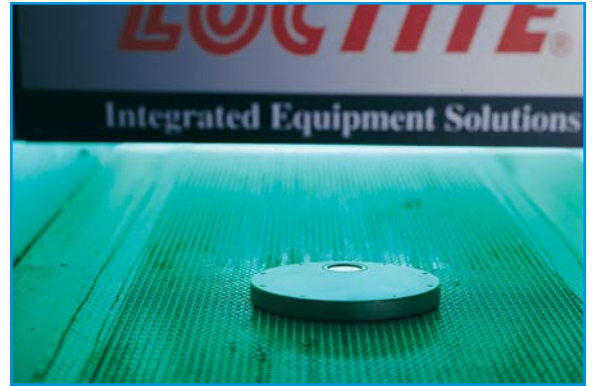

LOCTITE® RADIOMETER DOSIMETER FOR UV LED AND UV A/B LIGHT

Item Number: 1390323

LOCTITE® RADIOMETER DOSIMETER FOR VISIBLE LED AND UVV LIGHT

Item Number: 1265282

The LOCTITE® Radiometer Dosimeters are an industry first for measurement of LED Light Curing devices. The flat response curve makes these Radiometer Dosimeters uniquely qualified to measure narrow band wavelengths of LED Light Curing devices (see graphs below). They can also be used with traditional arc-lamps in Curing Chambers, Conveyors and Flood Lamps. This unit combines the all-in-one exposure, intensity measurement and profile memory capabilities into one device.

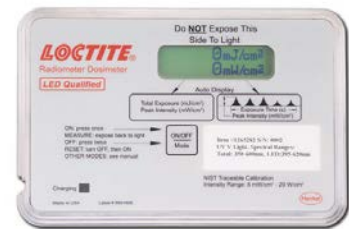

Features:

- Solid-state detector and ultra-stable amplifier technology to give lower noise, greater speed and higher accuracy.
- Digital display of peak intensity and total exposure.
- Graphical display of intensity versus time.
- Baseline profile reference plot allows on-the-spot comparison of the current performance of the curing unit with baseline.
- Built-in rechargeable batteries with charger included.

Radiometer Dosimeter includes:

- Instruction sheet #8901810
- AC charger
- Carry case
- Calibration certificate

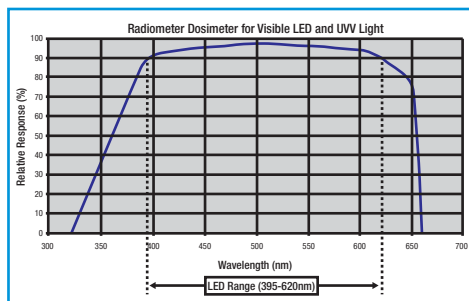
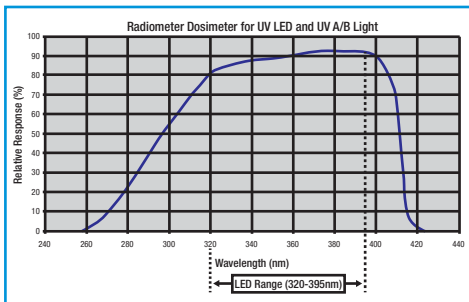

TECHNICAL SPECIFICATIONS		
Item Number	1390323 – LOCTITE® Radiometer Dosimeter for UV LED and UVV Light	1265282 – LOCTITE® Radiometer Dosimeter for Visible LED and UVV Light
Operating Temperature	0°C to 75°C internal temperature Note: Tolerates much higher external temperatures for short periods; audible alarm indicates when temperature is too high.	
Automatic Shutoff	5 minutes (if no buttons are pressed)	
Display	4 digit LCD	
Spectral Range, Total	280 to 405 nm	350 to 660 nm
Spectral Range, LED	320 to 395 nm	395 to 620 nm
Dimensions	160 mm L x 110 mm W x 12 mm D	
Weight	8.6 oz. (245 g)	
Typical Battery Life	Typical time between charges – 4 hours use	
Case Material	Aluminum, stainless steel	
Intensity Dosage Range	5 mW/cm ² – 20 W/cm ²	

Additional Accessories Sold Separately	
1421420 – adapter for CureJet™ 405 LED (1369538), CureJet™ Indigo® LED (1369537) and CureJet™ 375 LED (1369539)	
1403401 – adapter for 405 CureJet™ LED (976420) and Indigo® CureJet™ LED (1369537)	
1403405 – adapter for 7700, 7703, 7700-HD and 7703-HD LEDs	
1403403 – adapter/filter for Visible Arc Lamps. Includes a band-pass filter to limit the upper end of the wavelength being measured to 520 nm. LOCTITE® brand visible-cure adhesives react to wavelengths below 520 nm.	
1403402 – adapter for EQ CL 10 LED heads (1538499-365 nm) (1746633-405 nm)	
1527709 – adapter for AssureCure® Light Sources (1470724, 1470728, 1470729, 1470730)	

LOCTITE® 7020 UV SPOT RADIOMETER

Item Number: 1406024

The LOCTITE® 7020 UV Spot Radiometer is a self-contained, electro-optic instrument designed to measure and display the UV power density (irradiance) emitted by a UV spot curing system. The units displayed are watts per square centimeter. Decreased radiant power related to the degradation of UV lamps, light guides and reflectors can result in declines in process efficiency or incomplete curing of LOCTITE® light cure products.

The Radiometer is designed to provide the operator with instant feedback as to the performance of the spot-curing system based upon changes in the irradiance.



Features:

- Measure light guide degradation.
- Optimize multi-pole light guide positioning.
- Determine proper intensity required for curing various materials.
- Meets ISO™*-9000 requirements.
- Includes adapters for 3 mm, 5 mm and 8 mm size light guides.

TECHNICAL SPECIFICATIONS	
Range	0 to 20 Watts per square cm
Resolution	10 mW/cm ²
Display	3.5 mm digital LCD
Display Time	2.5 to 5 minutes
Spectral Range	320 to 390 nm (UVA region)
Power Source	Lithium Battery Stick
Battery Life	12,500 hours continuous operation (over 100,000 readings)
Overall Dimensions	163 mm long (6.42") x 53.6 mm diameter (2.11")
Weight	12.8 oz.
Case Material	Aluminum, polyester and quartz
Parts Included	(1) Calibration Certificate (1) Carrying Case (1) Instruction Sheet

* ISO = The International Organization for Standardization.

Index by Item Number

ITEM NO.	PRODUCT DESCRIPTION	PAGE NUMBER(S)	ITEM NO.	PRODUCT DESCRIPTION	PAGE NUMBER(S)
ANZ023N01	LOCTITE® Standard Nozzle Adapter/ Check Valve/Jam Nut.....	40	97970	LOCTITE® ¾" Black PTFE-Lined Feed Tube.....	69
39633	200/400 ml Mix Nozzle, Stepped Tip, 9.1" overall length, 13 mm inner diameter.....	66	97972	LOCTITE® ¼" Black PTFE Lined Feed Tube.....	69
88678	Syringe Air Line Adapter (2 pack).....	54	98003	LOCTITE® 7415 UV Benchtop Conveyor.....	81, 96
97001	LOCTITE® Hand Pump, 250 ml.....	31, 32	98004	LOCTITE® Electrodeless Lamp Assembly and Power Supply, 208 VAC single phase, 18 amps, 50/60 Hz.....	81, 96, 98
97006	LOCTITE® Precision Syringe Dispensing System.....	8, 11, 71, 72, 73, 74, 77	98005	LOCTITE® Electrodeless Lamp Assembly and Power Supply, 240 VAC single phase, 18 amps, 50/60 Hz.....	81, 96, 98
97042	LOCTITE® 50 ml Dual Cartridge Pneumatic Applicator.....	31, 34	98009	LOCTITE® Light Cure Dispense Valve.....	7, 17, 18, 19, 47, 51, 57, 62, 79
97101	LOCTITE® Digital Dispense Controller.....	15, 18, 21, 30, 42, 44, 48, 49, 50, 51, 52	98011	LOCTITE® Reactive Urethane Cartridge Dispenser.....	36, 39, 40
97111	LOCTITE® Manual Hand Held Applicator.....	41, 43, 46	98013	LOCTITE® Cyanoacrylate Dispense Valve.....	7, 17, 18, 19, 47, 51, 57, 62, 79
97112	LOCTITE® Pneumatic Hand Held Applicator, Foot Switch Activated.....	41, 44, 46	98022	LOCTITE® 300 ml Cartridge Pusher.....	20, 21, 48, 51
97113	LOCTITE® Stationary Applicator Valve.....	7, 17, 18, 19, 47, 48, 58, 62, 79	98033	LOCTITE® 075 Hot Melt Dispenser.....	36, 37, 40
97114	LOCTITE® Stationary Applicator Valve.....	7, 17, 18, 19, 47, 48, 58, 62, 79	98034	LOCTITE® 075-LT Hot Melt Dispenser.....	36, 37, 40
97115	LOCTITE® Electric Rotor Spray.....	15, 16, 51, 52	98035	LOCTITE® 175 Manual Dispenser.....	36, 39, 40
97116	LOCTITE® Pneumatic Hand Held Applicator, Finger Switch Activated.....	41, 44, 46	98036	LOCTITE® 175-AIR Pneumatic Dispenser.....	36, 38, 40
97119	LOCTITE® Advancing Slide (100 mm Stroke).....	15, 16, 52	98037	LOCTITE® 175-SPRAY Pneumatic Dispenser.....	36, 38, 40
97120	Air Supply Filter/Regulator.....	25	98039	LOCTITE® 7401 UV Chamber.....	81, 93
97130	LOCTITE® LV Hand Held Applicator.....	18, 19, 41, 42, 46	98040	LOCTITE® 175-AIR-HT Pneumatic Dispenser.....	36, 38, 40
97131	LOCTITE® Vari-Drop™ Applicator.....	41, 45, 46	98041	LOCTITE® 175-SPRAY-HT Pneumatic Dispenser.....	36, 38, 40
97132	LOCTITE® Vari-Drop™ Applicator.....	7, 41, 45, 46	98050	LOCTITE® Foot Pedal Dispenser.....	8, 12
97135	LOCTITE® Diaphragm Valve.....	47, 52, 58	98061	1¼" Polyethylene Tapered Tips, 16 Gauge, Grey, 1,000 pack.....	64
97136	LOCTITE® Diaphragm Valve.....	47, 52, 58	98062	1¼" Polyethylene Tapered Tips, 18 Gauge, Green, 1,000 pack.....	64
97141	LOCTITE® Pinch Tube Valve.....	24, 29	98063	1¼" Polyethylene Tapered Tips, 20 Gauge, Pink, 1,000 pack.....	64
97152	LOCTITE® Dual-Channel Automatic Controller.....	15, 16, 48, 49, 50, 51, 52, 62	98064	1¼" Polyethylene Tapered Tips, 22 Gauge, Blue, 1,000 pack.....	64
97200	LOCTITE® Valve Body Adapter for 98009 and 98013 Dispense Valves.....	62	98065	½" Stainless Steel Tips, 15 Gauge, Amber, 1,000 pack.....	64
97201	LOCTITE® Foot Switch Assembly.....	13, 25, 80, 82, 83, 87, 91	98066	½" Stainless Steel Tips, 18 Gauge, Green, 1,000 pack.....	64
97207	LOCTITE® 10 ml Clear Syringe Barrel Kit.....	68	98067	½" Stainless Steel Tips, 20 Gauge, Pink, 1,000 pack.....	64
97208	LOCTITE® 10 ml Syringe Air Line Adapter.....	11, 12, 68	98068	½" Stainless Steel Tips, 25 Gauge, Red, 1,000 pack.....	64
97211	LOCTITE® High Precision Monitor.....	16, 62	98069	1½" Polypropylene Tips Helical Thread, 15 Gauge, Amber, 1,000 pack.....	64
97215	LOCTITE® Cartridge-Syringe Adapter.....	64	98070	1½" Polypropylene Tips Helical Thread, 18 Gauge, Green, 1,000 pack.....	64
97216	LOCTITE® 10 ml Syringe Starter Kit.....	11, 12, 68	98071	1½" Polypropylene Tips Helical Thread, 20 Gauge, Pink, 1,000 pack.....	64
97220	LOCTITE® ¾" Feed Line Kit.....	43, 45, 52	98074	LOCTITE® High Density Polyethylene, 15 Gauge, White, 1,000 pack.....	64
97221	1¼" Polyethylene Tapered Tips, 16 Gauge, Grey, 50 pack.....	64	98080	½" Stainless Steel Tips, 22 Gauge, Blue, 1,000 pack.....	64
97222	1¼" Polyethylene Tapered Tips, 18 Gauge, Green, 50 pack.....	64	98082	1½" Polypropylene Tips Helical Thread, 25 Gauge, Red, 1,000 pack.....	64
97223	1¼" Polyethylene Tapered Tips, 20 Gauge, Pink, 50 pack.....	64	98083	LOCTITE® Fluorescence Detector.....	17
97224	1¼" Polyethylene Tapered Tips, 22 Gauge, Blue, 50 pack.....	64	98084	LOCTITE® Micro Needle Valve.....	47, 49, 57, 79
97225	½" Stainless Steel Tips, 15 Gauge, Amber, 50 pack.....	64	98090	LOCTITE® Shot Miser™ 1 Liter Reservoir.....	15, 19, 42, 44, 52
97226	½" Stainless Steel Tips, 18 Gauge, Green, 50 pack.....	64	98099	LOCTITE® Precision Filter and Regulator.....	49
97227	½" Stainless Steel Tips, 20 Gauge, Pink, 50 pack.....	64	98100	½" Stainless Steel Tips, 22 Gauge, Blue, 50 pack.....	64
97228	½" Stainless Steel Tips, 25 Gauge, Red, 50 pack.....	64	98114	¼" Stainless Steel Tips Helical Thread, 32 Gauge, Yellow, 50 pack.....	63
97229	1½" Polypropylene Tips Helical Thread, 15 Gauge, Amber, 50 pack.....	64	98115	¼" Stainless Steel Tips Helical Thread, 32 Gauge, Yellow, 1,000 pack.....	63
97230	1½" Polypropylene Tips Helical Thread, 18 Gauge, Green, 50 pack.....	64	98122	LOCTITE® 30 ml Pneumatic Syringe Barrel, Black, 500 pack.....	69
97231	1½" Polypropylene Tips Helical Thread, 20 Gauge, Pink, 50 pack.....	64	98125	LOCTITE® 3 ml Pneumatic Syringe Piston, 1,000 pack.....	69
97232	1½" Polypropylene Tips Helical Thread, 25 Gauge, Red, 50 pack.....	64	98127	LOCTITE® 10 ml Pneumatic Syringe Piston, 1,000 pack.....	69
97233	LOCTITE® Luer-Lok Adapter Kit.....	64	98128	LOCTITE® Cartridge Dispense Tip.....	64
97244	LOCTITE® 30 ml Clear Syringe Barrel Kit.....	68	98163	1½" Stainless Steel Tips Helical Thread, 14 Gauge, White, 50 pack.....	63
97245	LOCTITE® 30/55 ml Syringe Air Line Adapter.....	11, 12, 68	98164	1½" Stainless Steel Tips Helical Thread, 14 Gauge, White, 1,000 pack.....	63
97246	LOCTITE® UV Lamp - 400 watt Metal Halide.....	93, 94, 95	98165	1½" Stainless Steel Tips Helical Thread, 15 Gauge, Amber, 50 pack.....	63
97248	LOCTITE® Tip caps, 50 pack.....	64	98166	1½" Stainless Steel Tips Helical Thread, 15 Gauge, Amber, 1,000 pack.....	63
97261	LOCTITE® High Density Polyethylene, 15 Gauge, White, 50 pack.....	64	98167	1½" Stainless Steel Tips Helical Thread, 18 Gauge, Green, 50 pack.....	63
97262	LOCTITE® Needle Assortment Kit.....	45, 64	98168	1½" Stainless Steel Tips Helical Thread, 18 Gauge, Green, 1,000 pack.....	63
97263	LOCTITE® 10 ml Black Syringe Barrel Kit for UV Adhesives.....	68	98169	1½" Stainless Steel Tips Helical Thread, 20 Gauge, Pink, 50 pack.....	63
97264	LOCTITE® 30 ml Black Syringe Barrel Kit for UV Adhesives.....	68	98170	1½" Stainless Steel Tips Helical Thread, 20 Gauge, Pink, 1,000 pack.....	63
97294	LOCTITE® 30 ml Syringe Starter Kit.....	11, 12, 68	98171	1½" Stainless Steel Tips Helical Thread, 21 Gauge, purple, 50 pack.....	63
97295	LOCTITE® Valve Body Adapter for 97113 and 97114 Dispense Valves.....	62	98172	1½" Stainless Steel Tips Helical Thread, 21 Gauge, Purple, 1,000 pack.....	63
97541	LOCTITE® Replacement Tube Inserts, 10 pack.....	24	98173	1½" Stainless Steel Tips Helical Thread, 22 Gauge, Blue, 50 pack.....	63
			98174	1½" Stainless Steel Tips Helical Thread, 22 Gauge, Blue, 1,000 pack.....	63

ITEM NO.	PRODUCT DESCRIPTION	PAGE NUMBER(S)
98175	1½" Stainless Steel Tips Helical Thread, 23 Gauge, Orange, 50 pack	63
98176	1½" Stainless Steel Tips Helical Thread, 23 Gauge, Orange, 1,000 pack ...	63
98177	1½" Stainless Steel Tips Helical Thread, 25 Gauge, Red, 50 pack.....	63
98178	1½" Stainless Steel Tips Helical Thread, 25 Gauge, Red, 1,000 pack	63
98179	1½" Stainless Steel Tips Helical Thread, 27 Gauge, Light Grey, 50 pack	63
98180	1½" Stainless Steel Tips Helical Thread, 27 Gauge, Light Grey, 1,000 pack	63
98181	LOCTITE® Cartridge-Tube Fitting Adapter.....	64
98192	LOCTITE® 10 ml Tube Dispensing Manual Plunger.....	31, 33
98193	LOCTITE® 30 ml Tube Dispensing Manual Plunger.....	31, 33
98196	¼" Stainless Steel Tips Helical Thread, 18 Gauge, Green, 50 pack	63
98197	¼" Stainless Steel Tips Helical Thread, 18 Gauge, Green, 1,000 pack	63
98198	¼" Stainless Steel Tips Helical Thread, 20 Gauge, Pink, 50 pack.....	63
98199	¼" Stainless Steel Tips Helical Thread, 20 Gauge, Pink, 1,000 pack.....	63
98200	¼" Stainless Steel Tips Helical Thread, 21 Gauge, Purple, 50 pack.....	63
98201	¼" Stainless Steel Tips Helical Thread, 21 Gauge, Purple, 1,000 pack.....	63
98208	½" Stainless Steel Tips, 14 Gauge, Olive, 50 pack	64
98209	½" Stainless Steel Tips, 14 Gauge, Olive, 1,000 pack	64
98210	½" Stainless Steel Tips, 21 Gauge, Purple, 50 pack.....	64
98211	½" Stainless Steel Tips, 21 Gauge, Purple, 1,000 pack.....	64
98212	½" Stainless Steel Tips, 23 Gauge, Orange, 50 pack.....	64
98213	½" Stainless Steel Tips, 23 Gauge, Orange, 1,000 pack	64
98214	½" Stainless Steel Tips, 27 Gauge, Clear, 50 pack	64
98215	½" Stainless Steel Tips, 27 Gauge, Clear, 1,000 pack	64
98216	1" Stainless Steel Tips Helical Thread, 14 Gauge, White, 50 pack.....	63
98217	1" Stainless Steel Tips Helical Thread, 14 Gauge, White, 1,000 pack.....	63
98218	1" Stainless Steel Tips Helical Thread, 15 Gauge, Amber, 50 pack.....	63
98219	1" Stainless Steel Tips Helical Thread, 15 Gauge, Amber, 1,000 pack.....	63
98220	1" Stainless Steel Tips Helical Thread, 16 Gauge, Black, 50 pack.....	63
98221	1" Stainless Steel Tips Helical Thread, 16 Gauge, Black, 1,000 pack.....	63
98222	1" Stainless Steel Tips Helical Thread, 18 Gauge, Green, 50 pack	63
98223	1" Stainless Steel Tips Helical Thread, 18 Gauge, Green, 1,000 pack	63
98224	1" Stainless Steel Tips Helical Thread, 20 Gauge, Pink, 50 pack.....	63
98225	1" Stainless Steel Tips Helical Thread, 20 Gauge, Pink, 1,000 pack.....	63
98226	1" Stainless Steel Tips Helical Thread, 21 Gauge, Purple, 50 pack.....	63
98227	1" Stainless Steel Tips Helical Thread, 21 Gauge, Purple, 1,000 pack.....	63
98228	1" Stainless Steel Tips Helical Thread, 22 Gauge, Blue, 50 pack.....	63
98229	1" Stainless Steel Tips Helical Thread, 22 Gauge, Blue, 100 pack.....	63
98230	1" Stainless Steel Tips Helical Thread, 23 Gauge, Orange, 50 pack	63
98231	1" Stainless Steel Tips Helical Thread, 23 Gauge, Orange, 1,000 pack	63
98232	1" Stainless Steel Tips Helical Thread, 25 Gauge, Red, 50 pack.....	63
98233	1" Stainless Steel Tips Helical Thread, 25 Gauge, Red, 1,000 pack.....	63
98234	1" Stainless Steel Tips Helical Thread, 27 Gauge, Light Grey, 50 pack.....	63
98235	1" Stainless Steel Tips Helical Thread, 27 Gauge, Light Grey, 1,000 pack	63
98236	45° by ½" Stainless Steel Tips Helical Thread, 14 Gauge, White, 50 pack	63
98237	45° by ½" Stainless Steel Tips Helical Thread, 14 Gauge, White, 1,000 pack	63
98238	90° by ½" Stainless Steel Tips Helical Thread, 14 Gauge, White, 50 pack	63
98239	90° by ½" Stainless Steel Tips Helical Thread, 14 Gauge, White, 1,000 pack	63
98240	45° by ½" Stainless Steel Tips Helical Thread, 15 Gauge, Amber, 50 pack	63
98241	45° by ½" Stainless Steel Tips Helical Thread, 15 Gauge, Amber, 1,000 pack	63
98242	90° by ½" Stainless Steel Tips Helical Thread, 15 Gauge, Amber, 50 pack	63

ITEM NO.	PRODUCT DESCRIPTION	PAGE NUMBER(S)
98243	90° by ½" Stainless Steel Tips Helical Thread, 15 Gauge, Amber, 1,000 pack	63
98244	45° by ½" Stainless Steel Tips Helical Thread, 18 Gauge, Green, 50 pack	63
98245	45° by ½" Stainless Steel Tips Helical Thread, 18 Gauge, Green, 1,000 pack	63
98246	90° by ½" Stainless Steel Tips Helical Thread, 18 Gauge, Green, 50 pack	63
98247	90° by ½" Stainless Steel Tips Helical Thread, 18 Gauge, Green, 1,000 pack	63
98248	45° by ½" Stainless Steel Tips Helical Thread, 20 Gauge, Pink, 50 pack	63
98249	45° by ½" Stainless Steel Tips Helical Thread, 20 Gauge, Pink, 1,000 pack	63
98250	90° by ½" Stainless Steel Tips Helical Thread, 20 Gauge, Pink, 50 pack	63
98251	90° by ½" Stainless Steel Tips Helical Thread, 20 Gauge, Pink, 1,000 pack	63
98252	45° by ½" Stainless Steel Tips Helical Thread, 21 Gauge, Purple, 50 pack	63
98253	45° by ½" Stainless Steel Tips Helical Thread, 21 Gauge, Purple, 1,000 pack	63
98254	90° by ½" Stainless Steel Tips Helical Thread, 21 Gauge, Purple, 50 pack	63
98255	90° by ½" Stainless Steel Tips Helical Thread, 21 Gauge, Purple, 1,000 pack	63
98256	45° by ½" Stainless Steel Tips Helical Thread, 22 Gauge, Blue, 50 pack	63
98257	45° by ½" Stainless Steel Tips Helical Thread, 22 Gauge, Blue, 1,000 pack	63
98258	90° by ½" Stainless Steel Tips Helical Thread, 22 Gauge, Blue, 50 pack	63
98259	90° by ½" Stainless Steel Tips Helical Thread, 22 Gauge, Blue, 1,000 pack	63
98260	45° by ½" Stainless Steel Tips Helical Thread, 23 Gauge, Orange, 50 pack	63
98261	45° by ½" Stainless Steel Tips Helical Thread, 23 Gauge, Orange, 1,000 pack	63
98262	90° by ½" Stainless Steel Tips Helical Thread, 23 Gauge, Orange, 50 pack	63
98263	90° by ½" Stainless Steel Tips Helical Thread, 23 Gauge, Orange, 1,000 pack	63
98264	45° by ½" Stainless Steel Tips Helical Thread, 25 Gauge, Red, 50 pack	63
98265	45° by ½" Stainless Steel Tips Helical Thread, 25 Gauge, Red, 1,000 pack	63
98266	90° by ½" Stainless Steel Tips Helical Thread, 25 Gauge, Red, 50 pack	63
98267	90° by ½" Stainless Steel Tips Helical Thread, 25 Gauge, Red, 1,000 pack	63
98268	45° by ½" Stainless Steel Tips Helical Thread, 27 Gauge, Light Grey, 50 pack	63
98269	45° by ½" Stainless Steel Tips Helical Thread, 27 Gauge, Light Grey, 1,000 pack	63
98270	90° by ½" Stainless Steel Tips Helical Thread, 27 Gauge, Light Grey, 50 pack	63
98271	90° by ½" Stainless Steel Tips Helical Thread, 27 Gauge, Light Grey, 1,000 pack	63
98272	1¼" Polyethylene Tapered Tips, 14 Gauge, Tan, 50 pack	64
98273	1¼" Polyethylene Tapered Tips, 14 Gauge, Tan, 1,000 pack	64
98314	LOCTITE® 55 ml Clear Syringe Barrel Kit.....	68
98315	LOCTITE® 55 ml Black Syringe Barrel Kit for UV Adhesives.....	68
98316	LOCTITE® 30 ml Syringe Mounting Bracket Kit	79
98318	LOCTITE® 300 ml Cartridge Mounting Bracket Kit.....	79

ITEM NO.	PRODUCT DESCRIPTION	PAGE NUMBER(S)	ITEM NO.	PRODUCT DESCRIPTION	PAGE NUMBER(S)
98319A	LOCTITE® 300 ml Pneumatic Cartridge Dispensing Retainer.....	20, 22	98406	LOCTITE® Poppet Valve Mounting Bracket Kit	79
98320	LOCTITE® Syringe Adapter	79	98408	Poppet Valve Holder	79
98321	LOCTITE® Syringe Adapter	79	98413	LOCTITE® 7411-S UV Flood System	81, 94
98322	LOCTITE® Syringe Adapter	79	98414	LOCTITE® 50 ml Hand Pump.....	31, 32
98326	LOCTITE® Valve Mounting Bracket Kit	79	98416	LOCTITE® 55 ml Syringe Starter Kit	11, 12, 68
98327	LOCTITE® Valve Mounting Bracket Kit	79	98420	LOCTITE® Time Controlled Shutter	94
98328	LOCTITE® Mounting Rails for 3-Axis Benchtop Robots and Dispense Stations	79	98424	½" Stainless Steel Tips Helical Thread, 21 Gauge, Purple, 50 pack.....	63
98329	LOCTITE® Mounting Rails for 3-Axis Benchtop Robots and Dispense Stations	79	98425	½" Stainless Steel Tips Helical Thread, 21 Gauge, Purple, 1,000 pack.....	63
98336	LOCTITE® Mounting Adapter for 4-Axis Robots	79	98430	LOCTITE® 200/400 ml Mix Nozzle, 500 pack	66
98343	97113 and 97114 Valve Holder.....	79	98439	LOCTITE® Showcase Needle Variety Kit	64
98345	LOCTITE® Soft Squeeze Bottles, 2 fl. oz.....	31, 32	98440	Foot Switch.....	80, 82
98346	LOCTITE® Soft Squeeze Bottles, 4 fl. oz.....	31, 32	98441	LOCTITE® Micro Needle Valve Mounting Bracket Kit	79
98347	LOCTITE® Soft Squeeze Bottles, 8 fl. oz.....	31, 32	98444	LOCTITE® 50 ml Square Mix Nozzle, 10 pack	65
98348	LOCTITE® Dunce Cap for 2 oz. Bottle, 50 pack.....	32	98445	LOCTITE® Light Cure Acrylic Adhesive Dispensing System.....	14
98349	LOCTITE® Dunce Cap for 4 oz. and 8 oz. Bottle, 50 pack	32	98446	LOCTITE® Roller Assembly 1" wide band	64
98350	Luer-Slip Cap for 2 oz. Bottle, 50 pack.....	32	98447	LOCTITE® Replacement Rollers 1" wide, 3 pack.....	64
98351	Luer-Slip Cap for 4 oz. and 8 oz. Bottles, 50 pack.....	32	98448	LOCTITE® Roller Assembly 2" wide band	64
98357	LOCTITE® Z Height Adjustment Plate for 3-Axis Benchtop Robot	79	98449	LOCTITE® Replacement Rollers 2" wide, 3 pack.....	64
98364	LOCTITE® 50 ml Mix Nozzle, 2,000 pack	65	98452	LOCTITE® UV & Visible Light Safety Glasses, Orange	81, 82, 83, 84, 85, 86, 87, 90, 91, 92, 94, 95, 99
98367	LOCTITE® 200/400 ml Snap Tip Mix Nozzle, 1,000 pack.....	66, 92	98454	LOCTITE® 50 ml Mix Nozzle, 10 pack	65
98371	LOCTITE® Cartridge-Needle Adapter	64	98455	LOCTITE® 50 ml Mix Nozzle, 10 pack	65
98373	LOCTITE® 200/400 ml Square Mix Nozzle, 10 pack	66	98456	LOCTITE® 200/400 ml Mix Nozzle, 10 pack	66
98374	LOCTITE® 200/400 ml Square Mix Nozzle, 1,500 pack.....	66	98457	LOCTITE® 200/400 ml Mix Nozzle, 10 pack	66
98377	LOCTITE® Posi-Link™ Controller.....	9, 10, 23, 24, 77	98458	LOCTITE® Luer-Lok® Adapter	67
98378	LOCTITE® Posi-Link™ 5-25 Actuator	9, 10	98464	LOCTITE® 200/400 ml Mix Nozzle, 1,500 pack.....	66
98379	LOCTITE® Posi-Link™ 10-50 Actuator	9, 10, 23, 24	98472	LOCTITE® 50 ml Dual Cartridge Manual Applicator	31, 34
98385	¼" Polyethylene Tapered Tips Helical Thread and UV Light Block Additive, 14 Gauge, White, 50 pack.....	64	98473	LOCTITE® 50 ml Square Mix Nozzle, 10 pack	65
98386	¼" Polyethylene Tapered Tips Helical Thread and UV Light Block Additive, 14 Gauge, White, 1,000 pack.....	64	98474	LOCTITE® 200/400 ml Square Mix Nozzle, 10 pack.....	66
98387	¼" Polyethylene Tapered Tips Helical Thread and UV Light Block Additive, 16 Gauge, Grey, 50 pack.....	64	98479	LOCTITE® 3 ml Pneumatic Syringe Barrel and Piston Kit, Natural, 50 pack	69
98388	¼" Polyethylene Tapered Tips Helical Thread and UV Light Block Additive, 16 Gauge, Grey, 1,000 pack.....	64	98480	LOCTITE® 3 ml Pneumatic Syringe Barrel and Piston Kit, Natural, 1,000 pack	69
98389	¼" Polyethylene Tapered Tips Helical Thread and UV Light Block Additive, 18 Gauge, Green, 50 pack	64	98481	LOCTITE® 3 ml Pneumatic Syringe Barrel and Piston Kit, Black, 50 pack	69
98390	¼" Polyethylene Tapered Tips Helical Thread and UV Light Block Additive, 18 Gauge, Green, 1,000 pack	64	98482	LOCTITE® 3 ml Pneumatic Syringe Barrel and Piston Kit, Black, 1,000 pack	69
98391	¼" Polyethylene Tapered Tips Helical Thread and UV Light Block Additive, 20 Gauge, Pink, 50 pack.....	64	98483	LOCTITE® 5 ml Pneumatic Syringe Barrel and Piston Kit, Natural, 50 pack	69
98392	¼" Polyethylene Tapered Tips Helical Thread and UV Light Block Additive, 20 Gauge, Pink, 1,000 pack.....	64	98484	LOCTITE® 5 ml Pneumatic Syringe Barrel and Piston Kit, Natural, 1,000 pack	69
98393	¼" Polyethylene Tapered Tips Helical Thread and UV Light Block Additive, 22 Gauge, Blue, 50 pack.....	64	98485	LOCTITE® 5 ml Pneumatic Syringe Barrel and Piston Kit, Black, 50 pack	69
98394	¼" Polyethylene Tapered Tips Helical Thread and UV Light Block Additive, 22 Gauge, Blue, 1,000 pack.....	64	98486	LOCTITE® 5 ml Pneumatic Syringe Barrel and Piston Kit, Black, 1,000 pack	69
98395	LOCTITE® Interface Cable for Benchtop Robots.....	77	98487	LOCTITE® 10 ml Pneumatic Syringe Barrel and Piston Kit, Natural, 50 pack	69
98396	½" Stainless Steel Tips Helical Thread, 15 Gauge, Amber, 50 pack.....	63	98488	LOCTITE® 10 ml Pneumatic Syringe Barrel and Piston Kit, Natural, 1,000 pack	69
98397	½" Stainless Steel Tips Helical Thread, 15 Gauge, Amber, 1,000 pack.....	63	98489	LOCTITE® 10 ml Pneumatic Syringe Barrel and Piston Kit, Black, 50 pack	69
98398	½" Stainless Steel Tips Helical Thread, 18 Gauge, Green, 50 pack	63	98490	LOCTITE® 10 ml Pneumatic Syringe Barrel and Piston Kit, Black, 1,000 pack	69
98399	½" Stainless Steel Tips Helical Thread, 18 Gauge, Green, 1,000 pack	63	98491	LOCTITE® 30 ml Pneumatic Syringe Barrel and Piston Kit, Natural, 50 pack	69
98400	½" Stainless Steel Tips Helical Thread, 20 Gauge, Pink, 50 pack.....	63	98492	LOCTITE® 30 ml Pneumatic Syringe Barrel and Piston Kit, Natural, 500 pack	69
98401	½" Stainless Steel Tips Helical Thread, 20 Gauge, Pink, 1,000 pack.....	63	98493	LOCTITE® 30 ml Pneumatic Syringe Barrel and Piston Kit, Black, 50 pack	69
98402	½" Stainless Steel Tips Helical Thread, 22 Gauge, Blue, 50 pack.....	63	98494	LOCTITE® 30 ml Pneumatic Syringe Barrel and Piston Kit, Black, 500 pack	69
98403	½" Stainless Steel Tips Helical Thread, 22 Gauge, Blue, 1,000 pack.....	63			
98404	½" Stainless Steel Tips Helical Thread, 25 Gauge, Red, 50 pack.....	63			
98405	½" Stainless Steel Tips Helical Thread, 25 Gauge, Red, 1,000 pack.....	63			

ITEM NO.	PRODUCT DESCRIPTION	PAGE NUMBER(S)	ITEM NO.	PRODUCT DESCRIPTION	PAGE NUMBER(S)
98495	LOCTITE® 55 ml Pneumatic Syringe Barrel and Piston Kit, Natural, 250 pack	69	98661	1¼" Polyethylene Tapered Tips Helical Thread and UV Light Block Additive, 27 Gauge, Clear, 1,000 pack	64
98496	LOCTITE® 55 ml Pneumatic Syringe Barrel and Piston Kit, Natural, 50 pack	69	98667	LOCTITE® 200/400 ml Square Mix Nozzle, 10 pack	66
98497	LOCTITE® 55 ml Pneumatic Syringe Barrel and Piston Kit, Black, 50 pack	69	98668	LOCTITE® 200/400 ml Square Mix Nozzle, 500 pack	66
98498	LOCTITE® 55 ml Pneumatic Syringe Barrel and Piston Kit, Black, 250 pack	69	98672	LOCTITE® 200/400 ml Mix Nozzle, 10 pack	66
98499	LOCTITE® Tip Caps, 1,000 pack	64	98687	LOCTITE® Nozzle Adapter/Check Valve	40
98501	LOCTITE® Applicator Holder	6, 10, 11, 12, 42, 43, 44, 45, 68	132922	LOCTITE® Robot Interface Cable	25
98520	LOCTITE® Spray Valve	17, 47, 53, 58, 79	142646	¼" PTFE Lined Tube	25
98521	LOCTITE® Spray Controller	53	200022	LOCTITE® Empty 1 lb. HDPE Bottle	7, 19
98522	LOCTITE® LED Holder	80, 82	243335	LOCTITE® 200/400 ml Mix Nozzle, 6 pack	66
98544	LOCTITE® Hysol™ 050 Hot Melt Applicator	40	250052	LOCTITE® Soft Press Hand Held Pneumatic Applicator	20, 22
98545	LOCTITE® Hysol™ 050-HT Hot Melt Dispenser	40	376746	LOCTITE® Protection Gloves, White	90
98548	LOCTITE® Benchtop Peristaltic Dispenser	5, 6, 77	419115	LOCTITE® Nozzle Adapter/Check Valve, Single pack	40
98549	LOCTITE® Robot Interface Junction Box	77	606052	LOCTITE® 200/400 ml Mix Nozzle, 10 pack	66
98557	LOCTITE® 3 ml Pneumatic Syringe Barrel, Natural, 1,000 pack	69	720173	LOCTITE® 200/400 ml Mix Nozzle, 10 pack	66
98559	LOCTITE® 5 ml Pneumatic Syringe Barrel, Natural, 1,000 pack	69	720174	LOCTITE® 200/400 ml Mix Nozzle, 10 pack	66
98561	LOCTITE® 10 ml Pneumatic Syringe Barrel, Natural, 1,000 pack	69	720175	LOCTITE® Luer-Lok Adapter, 10 pack	67
98563	LOCTITE® 30 ml Pneumatic Syringe Barrel, Natural, 500 pack	69	720177	LOCTITE® 200/400 ml Mix Nozzle, 10 pack	66
98565	LOCTITE® 55 ml Pneumatic Syringe Barrel, Natural, 250 pack	69	720221	LOCTITE® 50 ml Mix Nozzle, 10 pack	65
98576	LOCTITE® 5 ml Pneumatic Syringe Barrel, Black, 1,000 pack	69	720222	LOCTITE® 50 ml Square Mix Nozzle, 1,500 pack	66
98578	LOCTITE® 10 ml Pneumatic Syringe Barrel, Black, 1,000 pack	69	720225	LOCTITE® 50 ml Mix Nozzle, 10 pack	65
98581	LOCTITE® 55 ml Pneumatic Syringe Barrel, Black, 250 pack	69	720226	LOCTITE® 200/400 ml Square Mix Nozzle, 10 pack	66
98584	LOCTITE® 5 ml Pneumatic Syringe Piston, 1,000 pack	69	720227	LOCTITE® 50 ml Square Mix Nozzle, 10 pack	65
98587	LOCTITE® 30/55 ml Pneumatic Syringe Piston, 1,000 pack	69	720230	LOCTITE® 50 ml Mix Nozzle, 10 pack	65
98595	LOCTITE® 7703 LED Light Source	80, 82	773794	LOCTITE® 50 ml Mix Nozzle, 50 pack	66
98610	LOCTITE® ¾" wide x ¾" NPT Dispense Nozzle, 10 pack	64	778273	LOCTITE® 50 ml Square Mix Nozzle, 10 pack	65
98611	½" Stainless Steel Tips Helical Thread, 23 Gauge, Orange, 50 pack	63	804261	LOCTITE® 200/400 ml Mix Nozzle, 1,500 pack	66
98612	½" Stainless Steel Tips Helical Thread, 23 Gauge, Orange, 1,000 pack	63	806038	LOCTITE® Indigo® 7703 LED Light Source	80, 82
98622	LOCTITE® 50 ml Mix Nozzle, 10 pack	65	826190	LOCTITE® 50 ml Square Mix Nozzle, 1,000 pack	65
98623	LOCTITE® 50 ml Mix Nozzle, 10 pack	65	830703	¼" Stainless Steel Tips Helical Thread, 14 Gauge, Olive, 1,000 pack	63
98624	¼" Stainless Steel Tips Helical Thread, 25 Gauge, Red, 50 pack	63	830704	¼" Stainless Steel Tips Helical Thread, 14 Gauge, Olive, 50 pack	63
98625	¼" Stainless Steel Tips Helical Thread, 25 Gauge, Red, 1,000 pack	63	848088	LOCTITE® 200/400 ml Square Mix Nozzle, 1,000 pack	66
98626	¼" Stainless Steel Tips Helical Thread, 27 Gauge, Clear, 50 pack	63	883976	LOCTITE® Digital Syringe Dispensing System	8, 12, 22, 71, 72, 73, 74, 77
98627	¼" Stainless Steel Tips Helical Thread, 27 Gauge, Clear, 1,000 pack	63	883979	LOCTITE® 7703-HD LED Light Source	80, 83
98628	¼" Stainless Steel Tips Helical Thread, 30 Gauge, Lavender, 50 pack	63	874905	LOCTITE® 200/400 ml Square Mix Nozzle, 10 pack	66
98629	¼" Stainless Steel Tips Helical Thread, 30 Gauge, Lavender, 1,000 pack	63	875472	LOCTITE® 200/400 ml Square Mix Nozzle, 650 pack	66
98632	LOCTITE® 50 ml Square Mix Nozzle, 1,000 pack	65	901459	LOCTITE® Vertical Syringe Stand	11, 12
98639	LOCTITE® Posi-Link™ 10-50 Actuator, 10 ml	10	916050	LOCTITE® Nozzle Adapter/Check Valve, 5 pack	40
98640	LOCTITE® Posi-Link™ 10-50 Actuator, 25 ml	10	916282	LOCTITE® 050A Hot Melt Dispenser	36, 37, 40
98641	LOCTITE® Posi-Link™ 50 ml Dual Cartridge Nest, 1:1 / 2:1	24	918088	LOCTITE® 200/400 ml Mix Nozzle, 10 pack	66
98642	LOCTITE® Posi-Link™ 50 ml Dual Cartridge Nest, 10:1	24	930705	LOCTITE® 200/400 ml Mix Nozzle, 1,000 pack	66
98643	LOCTITE® Posi-Link™ 5-25 Actuator, 5 ml	10	960356	LOCTITE® LED Cure Timer	80, 82, 83
98644	LOCTITE® Posi-Link™ 5-25 Actuator, 10 ml	10	967055	LOCTITE® LED Protective Tip Covers, 5 pack	82, 83
98645	LOCTITE® Posi-Link™ 5-25 Actuator, 25 ml	10	970655	LOCTITE® Luer-Lok® Adapter	67
98646	LOCTITE® Universal Syringe Bracket for Posi-Link™	79	980160	LOCTITE® High Intensity Ultraviolet Sources, 115 VAC; 60 Hz; 15 amp .81, 99 Replacement 5" UV Bulb – 300 W/in.	99
98647	LOCTITE® 50 ml Dual Cartridge Bracket for Posi-Link™	79	980161	LOCTITE® ¼" Clear Polyethylene Feed Tube	69
98652	LOCTITE® Light-blocking Shield for Dispense Tips, 10 pack	64	981821	LOCTITE® ⅜" Clear Polyethylene Feed Tube	69
98653	LOCTITE® 200/400 ml Square Mix Nozzle, 1,000 pack	66	981866	LOCTITE® ¼" Clear Nylon Feed Tube for Pump-A-Bead™	69
98655	LOCTITE® 3 ml Pneumatic Syringe Barrel, Black (1,000 pack)	69	981994	LOCTITE® Cartridge Adapter	64
98656	LOCTITE® 3 ml Syringe Air Line Adapter	11, 12, 68	982644	LOCTITE® Bond-A-Matic® 3000 Dispenser	5, 7, 45
98657	LOCTITE® 5 ml Syringe Air Line Adapter	11, 12, 68	982719	LOCTITE® Bond-A-Matic® 3000 Reservoir, 0 to 15 psi	15, 16, 17, 18, 19, 42, 44, 48, 49, 50, 51, 52, 53, 62
98658	1¼" Polyethylene Tapered Tips Helical Thread and UV Light Block Additive, 25 Gauge, Red, 50 pack	64	982720	LOCTITE® Bond-A-Matic® 3000 Reservoir, 0 to 100 psi	15, 16, 17, 18, 19, 42, 44, 48, 49, 50, 51, 52, 53, 62
98659	1¼" Polyethylene Tapered Tips Helical Thread and UV Light Block Additive, 25 Gauge, Red, 1,000 pack	64	982722	LOCTITE® Bond-A-Matic® 3000 Reservoir, 0 to 15 psi	15, 17, 18, 19, 42, 43, 44, 48, 49, 50, 51, 52, 53, 62
98660	1¼" Polyethylene Tapered Tips Helical Thread and UV Light Block Additive, 27 Gauge, Clear, 50 pack	64	982723	LOCTITE® Bond-A-Matic® 3000 Reservoir, 0 to 15 psi	15, 17, 18, 19, 42, 43, 44, 48, 49, 50, 51, 52, 53, 62

ITEM NO.	PRODUCT DESCRIPTION	PAGE NUMBER(S)	ITEM NO.	PRODUCT DESCRIPTION	PAGE NUMBER(S)
982727	LOCTITE® Bond-A-Matic® 3000 Reservoir, 0 to 100 psi	15, 17, 18, 19, 42, 43, 44, 48, 49, 50, 51, 52, 53, 62	988173	LOCTITE® Replacement Light Blocking Curtain	94
982880	LOCTITE® 4 Liter Gravity Feed Reservoir	59	988896	LOCTITE® Syringe Finger Switch	10, 11, 12
983050	LOCTITE® Visible Wavelength Lamp Option	93, 94, 95	989038	LCA Tubing Adhesive Applicator Bushing, 2 mm	14
983091	LOCTITE® Replacement 6" UV Bulb	97	989039	LCA Tubing Adhesive Applicator Bushing, 3 mm	14
983330	LOCTITE® Positive Displacement Pump	15, 59	989040	LCA Tubing Adhesive Applicator Bushing, 4 mm	14
983436	LOCTITE® 200 ml Dual Cartridge Manual Applicator	31, 34	989041	LCA Tubing Adhesive Applicator Bushing, 5 mm	14
983437	LOCTITE® 200 ml Dual Cartridge Pneumatic Applicator	31, 34	989042	LCA Tubing Adhesive Applicator Bushing, 6 mm	14
983438	LOCTITE® 400 ml Dual Cartridge Manual Applicator	31, 34	989268	LOCTITE® 0.014" Nozzle Kit	17, 53
983439	LOCTITE® 400 ml Dual Cartridge Pneumatic Applicator	31, 34	989269	LOCTITE® 0.028" Nozzle Kit	17, 53
983462	LOCTITE® Exhaust Plenum	96	989347	LOCTITE® Adapter for 250 ml Squeeze Tubes	22
983464	LOCTITE® Sight Shield, Snap In, Box End Style	96	989516	LOCTITE® 200/400 ml Mix Nozzle, 50 pack	66
983469	LOCTITE® Fusion D Bulb	96, 98	989518	LOCTITE® 200/400 ml Mix Nozzle, 10 pack	66
983470	LOCTITE® Fusion H Bulb	96, 98	989620	LOCTITE® AC Battery Charger	82
983471	LOCTITE® V Bulb - 300 W/in.	96, 98	989656	LOCTITE® LR-C Teach Point Software for LOCTITE® Benchtop Robots	77
983509	LOCTITE® 50 ml Mix Nozzle, 2,000 pack	65	989763	LOCTITE® 200 Series Light Curtain Guarding System	79
983533	LOCTITE® Replacement 50 ml Applicator Plunger, 1:1 Ratio	34	989771	LOCTITE® 300 Series Light Curtain Guarding System	79
983534	LOCTITE® Replacement 50 ml Applicator Plunger, 2:1 Ratio	34	989777	LOCTITE® 400/500 Series Light Curtain Guarding System	79
983914	Poppet Valve Mounting Bracket Kit	79	989787	LOCTITE® 200 Series Slide Door Guarding System	79
984209	LOCTITE® Optional 50 ml Applicator Plunger, 4:1 Ratio	34	989788	LOCTITE® 300 Series Slide Door Guarding System	79
984210	LOCTITE® 4:1 Conversion Kit	34	989789	LOCTITE® 400/500 Series Slide Door Guarding System	79
984211	LOCTITE® 4:1 Conversion Kit	34	989852	LOCTITE® SCARA Light Curtain Guarding System	79
984261	LOCTITE® Standard Adapter for 300 ml Cartridge	40	994480	LOCTITE® Reservoir Liner	7, 19
984262	LOCTITE® Standard 1-Hole Nozzle	40	997569	LOCTITE® Silicone Grease	49
984263	LOCTITE® Adapter/Check Valve for Specialty Nozzles	40	998353	LOCTITE® Reservoir Liner	19
984264	LOCTITE® Needle Jet Nozzle	40	998390	LOCTITE® Vari-Drop™ Applicator Brushes, 10 pack	64
984268	LOCTITE® 3-Hole Nozzle	40	998400	LOCTITE® Dial-A-Seal® Applicator	61
984272	LOCTITE® Injection Needle Nozzle	40	1003327	LOCTITE® Pistol Grip and Timer	80, 83
984621	LOCTITE® Replacement Foot Switch	53	1008335	LOCTITE® S440 Series SCARA-N Robot, 440 mm, 4 Axis, 220 V CE Rated	77
984650	LOCTITE® Air Line Filter for Syringe Dispensing	68	1008337	LOCTITE® S440 Series SCARA-N Robot, 440 mm, 4 Axis, 110 V CE Rated	77
984688	LOCTITE® Silicone Tubing for Dispense Valve Purging, 10 Pack	69	1008338	LOCTITE® S440 SCARA-N Robot, 4 Axis	70, 77
984691	LOCTITE® Advancing Slide (2" Stroke)	15	1008339	LOCTITE® S440 Series SCARA-N Robot, 440 mm, 3 Axis, 220 V	77
984832	LOCTITE® Tube Fitting: ¼" male NPT x ¼" feed tube, 10 pack	64	1008340	LOCTITE® S440 Series SCARA-N Robot, 440 mm, 3 Axis, 110 V CE Rated	77
984833	LOCTITE® Tube Fitting: ¼" male NPT x ⅜" feed tube, 10 pack	64	1008351	LOCTITE® S440 SCARA-N Robot, 3-Axis	70, 77
984967	LOCTITE® Replacement Silicone Work Surface	94	1008552	LOCTITE® S440 Series SCARA-N Robot, 440 mm, 3 Axis, 220 V CE Rated	77
985110	LOCTITE® 2-Hole Nozzle	40	1015106	LOCTITE® Teach Pendant	77
985111	LOCTITE® 3-Hole Nozzle	40	1022006	LOCTITE® Digital Multi-Functional Controller	15, 17, 21, 48, 49, 50, 51, 52, 59
985112	LOCTITE® Diagonal Extension Nozzle	40	1032026	LOCTITE® 200/400 ml Mix Nozzle, 10 pack	66
985113	LOCTITE® Needle Extension Nozzle	40	1034024	LOCTITE® Replacement 50 ml Applicator Plunger, 10:1 Ratio	34
985114	LOCTITE® Spreader Extension Nozzle	40	1034026	LOCTITE® 50 ml Dual Cartridge Manual Applicator, S-50 Cartridge	31, 34
985115	LOCTITE® L-Nozzle	40	1034030	LOCTITE® LED Mounting Bracket Kit	79
985122	LOCTITE® Standard Medium Spray Nozzle	40	1034575	LOCTITE® 50 ml-B Mix Nozzle, 10 pack	34, 65
985211	LOCTITE® Narrow Spray Nozzle	40	1041620	LOCTITE® DuraPump™ Pneumatic Meter Mix System for MMA Chemistry	28
985216	LOCTITE® Ultra-Wide Spray Nozzle	40	1041633	LOCTITE® DuraPump™ Pneumatic Meter Mix System	28
985225	LOCTITE® 1-Hole Nozzle	40	1041635	LOCTITE® DuraPump™ Programmable Meter Mix System	27
985246	LOCTITE® 400 ml Dual Cartridge Manual Applicator	31, 34	1041636	LOCTITE® DuraPump™ Pneumatic Meter Mix System for MMA Chemistry	28
985249	LOCTITE® 400 ml Dual Cartridge Pneumatic Applicator	31, 34	1041637	LOCTITE® DuraPump™ Pneumatic Meter Mix System	28
985281	LOCTITE® Bracket	49	1041638	LOCTITE® DuraPump™ Programmable Meter Mix System	27
985397	LOCTITE® Air Filter, Regulator, Gauge	13, 38, 40	1041639	LOCTITE® DuraPump™ Programmable Meter Mix System	27
986000	LOCTITE® Pump-A-Bead™ II Dispenser	55, 60	1041641	LOCTITE® DuraPump™ Pneumatic Meter Mix System	28
986025	Nozzle: 0.025" Diameter for LOCTITE® Poppet Valve (986300)	69	1041643	LOCTITE® DuraPump™ Pneumatic Meter Mix System	28
986035	Nozzle: 0.035" Diameter for LOCTITE® Poppet Valve (986300)	69	1041644	LOCTITE® DuraPump™ Programmable Meter Mix System	27
986060	Nozzle: 0.060" Diameter for LOCTITE® Poppet Valve (986300)	69	1041647	LOCTITE® DuraPump™ Pneumatic Meter Mix System for MMA Chemistry	28
986086	LOCTITE® Optional 50 ml Applicator Plunger, 10:1 Ratio	34	1041648	LOCTITE® DuraPump™ Pneumatic Meter Mix System	28
986300	LOCTITE® Poppet Valve	47, 55, 58, 69, 79	1041649	LOCTITE® DuraPump™ Programmable Meter Mix System	27
986301	Valve Rebuild Kit for LOCTITE® Poppet Valve (986300)	69	1044246	LOCTITE® Aero Nozzle for Silicones in aerosol cans, 10 pack	64
987512	LOCTITE® Operations Box	77			
988000	LOCTITE® Solenoid Valve Module	71, 72, 73, 74, 75, 76, 77			
988159	LOCTITE® Replacement Filter Glass for 98413	94			

1044247	LOCTITE® Cartridge-Syringe Adapter	64	1176444	LOCTITE® Pistol Grip Trigger	48, 51
1044249	LOCTITE® Cable Connector Plug Kit	17	1180632	LOCTITE® CureJet™ Quad Controller	80, 84, 85, 87
1044301	LOCTITE® LED-HD Pistol Grip Battery Kit	83	1180633	LOCTITE® 10 ml Clear Manual Syringe Kit, 1,000 pack	69
1045339	LOCTITE® Cartridge-Needle Adapter	64	1180634	LOCTITE® 35 ml Clear Manual Syringe Kit, 500 pack	69
1046901	LOCTITE® High Pressure 300 ml Benchtop Cartridge Dispenser	20, 21, 56	1180636	LOCTITE® 35 ml Clear Manual Syringe Kit, 10 pack	69
1049138	LOCTITE® High Pressure Dispense Valve - 50 Bar	47, 56, 58	1180637	LOCTITE® 10 ml Clear Manual Syringe Kit, 10 pack	69
1051627	LOCTITE® Hose Heat Controller	29	1180638	LOCTITE® 6 ml Clear Manual Syringe Kit, 10 pack	69
1051629	LOCTITE® Low Level Sensing Option – Poly Tank	29	1180639	LOCTITE® 3 ml Clear Manual Syringe Kit, 10 pack	69
1051630	LOCTITE® Low Level Sensing Option – Ni Plated Steel Tank	29	1195937	LOCTITE® Compact Rotor Pump Controller	25
1051651	LOCTITE® Dual Tank Stand	29	1196160	LOCTITE® Compact Rotor Pump Dispenser	25
1051654	LOCTITE® Tank Heater and Controls Option	29	1197606	LOCTITE® 50 ml Mix Nozzle, Taper Tip, 2.4"	65
1051655	LOCTITE® Agitator Assembly Option	29	1228790	LOCTITE® 200/400 ml Stepped Tip Mix Nozzle	66
1051656	LOCTITE® Follower Plate with Handle Option	29	1233800	LOCTITE® 10 ml Gel CA Syringe Dispenser	31, 33
1051657	LOCTITE® Disposable Desiccant Air Dryer Option	29	1241543	LOCTITE® UV Curing Conveyor	81, 97
1051659	LOCTITE® 7 Liter Ni Plated Steel Gravity Tank with Cover	29	1244443	SS, PTFE-Lined, 21 Gauge, 50 pack	64
1051660	LOCTITE® 9.5 liter Poly Gravity Tank with Cover	29	1244444	½" Stainless Steel Tips Helical Thread, 14 Gauge, Olive, 50 pack	63
1051662	LOCTITE® Dispense Valve – MMA	29	1248606	LOCTITE® 200/400 ml Spray Tip Mix Nozzle	67
1051666	LOCTITE® DuraPump™ Heated Hose Option – 144"	29	1255058	½" Stainless Steel Tips Helical Thread, 27 Gauge, Light Grey, 1,000 pack	63
1051667	LOCTITE® DuraPump™ Heated Hose Option – 96"	29	1255059	½" Stainless Steel Tips Helical Thread, 27 Gauge, Light Grey, 50 pack	63
1051668	LOCTITE® DuraPump™ Heated Hose Option – 48"	29	1256497	½" Stainless Steel Tips Helical Thread, 30 Gauge, Lavender, 1,000 pack	63
1051669	LOCTITE® Hose for Dispense Valve – ¾" x 96" MMA	29	1256848	½" Stainless Steel Tips Helical Thread, 30 Gauge, Lavender, 50 pack	63
1051670	LOCTITE® Hose for Dispense Valve – ¾" x 24" MMA	29	1259190	LOCTITE® 50 ml Round Mix Nozzle, 10 pack	65
1051692	LOCTITE® Hose for Dispense Valve – ¾" x 24" General-Purpose	29	1265282	LOCTITE® Radiometer Dosimeter for Visible LED and UV Light	81, 82, 83, 85, 86, 98, 101
1051694	LOCTITE® Hose for Dispense Valve – ¾" x 144" MMA	29	1328354	LOCTITE® Solenoid Valve Module, 12 v	71
1051695	LOCTITE® Precision Hydraulic Flow Controller	29	1328356	LOCTITE® Teach Pendant	71, 72, 73, 74, 75, 76
1053227	LOCTITE® Adapter Cable	71, 72, 73, 74	1328358	LOCTITE® 12 Volt Interface Junction Box	71
1053262	LOCTITE® 200/400 ml Mix Nozzle, 2,000 pack	66	1329200	LOCTITE® 50 ml Mix Nozzle, Taper Tip, 3.0", 100 pack	30, 65
1061921	LOCTITE® 50 ml Mix Nozzle, 100 pack	65	1329222	Interface Cable	71, 72, 73, 74, 75, 76
1065306	200/400 ml Mix Nozzle, Stepped Tip, 11.2"	66	1333333	LOCTITE® Connecting Cable	80, 88
1065313	200/400 ml Mix Nozzle, Stepped Tip, 11.6"	66	1334299	LOCTITE® 50 ml Mix Nozzle, 100 pack	30, 65
1079254	LOCTITE® Dispense Valve – General-Purpose	29	1335000	Sealing Set with Housing	25
1079256	LOCTITE® Dispense Valve – MMA	29	1335041	Stator with Housing	25
1083845	LOCTITE® 50 ml F Tube Squeeze Dispenser	31, 33	1335042	Pump Unit without Motor	25
1084092	LOCTITE® 200/400-F ml Cartridge Mix Nozzle	67	1335043	Repair Kit	25
1084093	LOCTITE® 200/400-F ml Cartridge Mix Nozzle	67	1359255	LOCTITE® LED Flood Controller	80, 88
1084255	LOCTITE® 200/400 ml 4:1 Cartridge Mix Nozzle	67	1364033	LOCTITE® LED Controller	80, 84, 85, 86
1093940	LOCTITE® Manual Cartridge Applicator 300 ml	20, 31	1369537	LOCTITE® CureJet™ Indigo® LED	80, 86, 87, 101
1093981	LOCTITE® Dual Cartridge Manual Applicator 300 ml x 300 ml	31, 35	1369538	LOCTITE® CureJet™ 405 LED	80, 85, 87, 101
1095801	LOCTITE® External Mix Assembly	48	1369539	LOCTITE® CureJet™ 375 LED	80, 84, 87
1098256	LOCTITE® 200/400 ml Mix Nozzle, 1,200 pack	66	1370351	LOCTITE® Interconnecting Cable, 1 m	84, 85, 86, 87
1100962	LOCTITE® 300 ml Single-Axis Cartridge Mix Nozzle	67	1370352	LOCTITE® Interconnecting Cable, 3 m	84, 85, 86, 87
1100963	LOCTITE® 300 ml Single Axis Cartridge Mix Nozzle	67	1372751	LOCTITE® Fixmaster® Universal Dispenser	31, 35
1102257	LOCTITE® Multiplexer	83	1390321	LOCTITE® Integrated Semiautomatic Dispenser, 0 to 100 psi	5, 7, 42, 44, 48, 49, 50, 51, 52, 71, 72, 73, 74, 77
1113131	LOCTITE® Focused UV Flood Curing System	81, 95	1390322	LOCTITE® Integrated Semi-Automatic Dispenser, 0 to 15 psi	5, 7, 42, 44, 48, 49, 50, 51, 52, 71, 72, 73, 74, 77
1116241	LOCTITE® 50 ml Mix Nozzle, 2,500 pack	65	1390323	LOCTITE® Radiometer Dosimeter for UV LED and UV A/B Light	81, 84, 89, 90, 91, 93, 94, 95, 96, 97, 98, 99, 101
1143355	LOCTITE® 50 ml Mix Nozzle with Integral Needle Adapter, 2,000 pack	65	1403401	LOCTITE® Dosimeter adapter for 405 CureJet™ LED (976420) and Indigo® CureJet™ LED (976418)	91, 101
1145743	LOCTITE® 50 ml Mix Nozzle with Integral Needle Adapter, 10 pack	65	1403402	Adapter for EQ CL 10 LED Heads	91, 101
1146078	LOCTITE® Stainless Steel, PTFE Lined, 25 Gauge, 1,000 pack	64	1403403	LOCTITE® Adapter/Filter for Visible Arc Lamps	89, 90, 93, 94, 95, 96, 98, 101
1146079	LOCTITE® Stainless Steel, PTFE Lined, 25 Gauge, 50 pack	64	1403405	LOCTITE® Dosimeter Adapter	80, 82, 83, 101
1147763	LOCTITE® Cartridge-Dispense Valve Adapter Assembly Fischbach Thread x ¼" male NPT	64	1405182	LOCTITE® 50 ml Square Mix Nozzle, 5,000 pack	65
1153502	LOCTITE® High Pressure Dispense Valve -150 Bar	47, 56, 58	1406023	LOCTITE® Spray Valve Controller	15, 17, 53, 77
1167582	LOCTITE® LED Flood Cure, 375	80, 88, 89	1406024	LOCTITE® 7020 UV Spot Radiometer	81, 92, 102
1167586	LOCTITE® Mixing Manifold – All ratios and products	29	1421420	LOCTITE® Dosimeter Adapter for LOCTITE® CureJet™ 405 LED (1369538), LOCTITE® CureJet™ Indigo® LED (1369537) and LOCTITE® CureJet™ 375 LED (1369539)	84, 85, 86, 101
1167589	LOCTITE® LED Flood Cure, Indigo®	80, 88, 89			
1167593	LOCTITE® LED 405 nm Cure Array	80, 88, 89			
1174337	LOCTITE® Micro Dispense Scale	6, 10, 11, 12, 17, 18, 42, 44, 48, 49, 50, 51, 62, 89			
1176431	LOCTITE® 6 ml Clear Manual Syringe Kit, 1,000 pack	69			
1176432	LOCTITE® 3 ml Clear Manual Syringe Kit, 1,000 pack	69			

1427231	LOCTITE® 7700 LED Light Source.....	80, 82	1573141	LOCTITE® 50 ml Square Mix Nozzle, Taper Tip, 4.8" , 10 count.....	65
1427232	LOCTITE® 7700-HD LED Light Source.....	80, 83	1573142	LOCTITE® 50 ml Square Mix Nozzle, Taper Tip, 4.8" , 1,000 count.....	65
1434516	LOCTITE® 50 ml CA Mix Nozzle, 5 pack.....	65	1573143	LOCTITE® 50 ml Mix Nozzle, Stepped Tip, 5.2" , 1,000 count.....	65
1440016	LOCTITE® 50 ml Mix Nozzle, 100 pack.....	65	1573144	LOCTITE® 50 ml Mix Nozzle, Stepped Tip, 5.2" , 10 count.....	65
1440017	LOCTITE® 50 ml Mix Nozzle, 100 pack.....	30, 65	1573145	LOCTITE® 50 ml Mix Nozzle, Stepped Tip, 4.4" , 1,000 count.....	65
1440018	LOCTITE® 50 ml Mix Nozzle, 100 pack.....	65	1573146	LOCTITE® 50 ml Mix Nozzle, Stepped Tip, 4.4".....	65
1444133	LOCTITE® 50 ml Dual Cartridge Dispenser, 4/10:1 B.....	30	1573147	LOCTITE® 50 ml Mix Nozzle, Stepped Tip, 6.2" , 1,000 count.....	65
1444135	LOCTITE® 50 ml Dual Cartridge Dispenser, 1/2:1 A.....	30	1573149	LOCTITE® 50 ml Mix Nozzle, Stepped Tip, 6.2" , 10 count.....	65
1444139	LOCTITE® Anti-drip Valve, 500 pack.....	30	1573151	LOCTITE® 50 ml Square Mix Nozzle, Taper Tip, 4.8" , 1,000.....	65
1445944	LOCTITE® Anti-drip Valve, 100 pack.....	30	1573153	LOCTITE® 50 ml Square Mix Nozzle, Taper Tip, 4.8".....	65
1447728	LOCTITE® Single Line Array LED – Controller.....	80, 88, 90	1573154	LOCTITE® 50 ml Square Mix Nozzle, Taper Tip, 4.8".....	65
1449336	LOCTITE® Single Line Array LED – 405.....	80, 90	1573156	LOCTITE® 50 ml Square Mix Nozzle.....	65
1449337	LOCTITE® Single Line Array LED – 365.....	80, 90	1578317	LOCTITE® 500D Benchtop Robot.....	70, 74
1452395	LOCTITE® 300D Benchtop Robot.....	70, 72	1585606	¼" Stainless Steel Tips Helical Thread, 22 Gauge, Blue, 50 pack.....	63
1452396	LOCTITE® 400D Benchtop Robot.....	70, 73	1585607	¼" Stainless Steel Tips Helical Thread, 22 Gauge, Blue, 1,000 pack.....	63
1461974	LOCTITE® 24 Volt Interface Junction Box.....	71, 72, 73, 74, 75, 76	1597107	LOCTITE® 200D Benchtop Robot.....	70, 71
1464916	LOCTITE® 30 ml PUR™ Controller.....	8, 13	1597635	LOCTITE® 050A-HT Hot Melt Dispenser.....	36, 37, 40
1464917	LOCTITE® 30 ml PUR™ Pre Heater.....	8, 13	1611449	LOCTITE® EQ VA10 Micro Diaphragm Valve.....	17, 18, 19, 47, 50, 57
1464918	LOCTITE® 30 ml PUR™ Dispense Head.....	8, 13	1611450	LOCTITE® Replacement Nozzle/Check Valve.....	40
1470724	LOCTITE® AssureCure® Light Sources, Single.....	100, 101	1635175	¼" Stainless Steel Tips Helical Thread, 23 Gauge, Orange, 1,000 pack.....	63
1470726	LOCTITE® AssureCure® Optic Processor.....	100	1635176	¼" Stainless Steel Tips Helical Thread, 23 Gauge, Orange, 50 pack.....	63
1470727	LOCTITE® AssureCure® Interface Module with LED Light Source.....	100	1635546	LOCTITE® EQ RB10 Rotary Dispense System.....	78
1470728	LOCTITE® AssureCure® Double Light Source Fiber.....	100, 101	1638885	LOCTITE® EQ VA10 Mounting Bracket.....	79
1470729	LOCTITE® AssureCure® Triple Light Source Fiber.....	100, 101	1661548	LOCTITE® EQ CL15 UV Wand Systems.....	81, 92
1470730	LOCTITE® AssureCure® Quad Light Source Fiber.....	100, 101	1664246	LOCTITE® CL15 Replacement Lamp.....	92
1470771	LOCTITE® AssureCure® Detector Fiber.....	100	1667508	LOCTITE® SD15 Heat Controller.....	13
1471134	LOCTITE® AssureCure® Optic Module.....	100	1667509	LOCTITE® SD15 Tip Heater.....	13
1483245	LOCTITE® Connection Cable, Length 2.1 m.....	90	1670898	LOCTITE® EQ RB15 200 D Gantry Robot.....	70, 76
1483249	Needle–All SS, ½" 18G.....	13	1681289	Stator with Housing.....	25
1483250	Needle–All SS, ½" 20G.....	13	1681290	Repair Kit.....	25
1483262	Needle–All SS, ½" 21G.....	13	1681291	Pump Unit without Motor.....	25
1483264	Needle–All SS, ½" 23G.....	13	1682223	LOCTITE® EQ RB20 500 D Dual Benchtop Robot.....	70, 75
1483265	Needle–All SS, ½" 25G.....	13	1714379	LOCTITE® EQ HD10 Pneumatic 300 ml Cartridge Dispenser.....	20, 22
1493310	LOCTITE® 50 ml S-Style Dual Cartridge Pneumatic Applicator.....	31, 34	1730181	LOCTITE® EQ VA15 Diaphragm Valve.....	47, 51, 57
1500889	Needle–All SS, ½" 19G.....	13	1741601	LOCTITE® Compact Micro Rotor Pump Dispenser 1.0.....	25
1500890	LOCTITE® 400 ml Dual Cartridge Pneumatic Applicator.....	31, 35	1746633	LOCTITE® EQ CL10 6 mm LED Head 2.7 m – 405 nm.....	91, 101
1500901	LOCTITE® Lens System to Boost Intensity.....	90	1750074	LOCTITE™ EQ CL10 405 nm; 6mm LED Lens.....	91
1506477	LOCTITE® CA Volumetric Handpump.....	31, 32	1838885	LOCTITE™ EQ VA25 Dispense Valve - 50 Bar.....	47, 56, 58
1506478	LOCTITE® Fluid Element, Black.....	32	1850211	LOCTITE® EQ VA30 Jet Controller.....	54
1506479	LOCTITE® Fluid Element, Clear.....	32	1850212	LOCTITE® EQ VA30 Jet Valve.....	47, 54
1514629	LOCTITE® EQ SD10 Digital Syringe Dispenser.....	8, 11	1871874	200µm Nozzle Plate.....	54
1514634	LOCTITE™ EQ CL10 Quad LED Controller.....	81, 91	1871875	Diaphragm FFKM (5 pack).....	54
1514636	LOCTITE™ EQ CL10 Single LED Controller.....	81, 91	1871876	Feed Tubes Black (50 pack).....	54
1527709	Adapter for AssureCure® Light Sources.....	100, 101	1871877	Cleaning Kit for 200µm Nozzle.....	54
1528963	Pressure Sensor.....	25	1871878	Cleaning Kit for 125µm Nozzle.....	54
1538496	LOCTITE™ EQ CL10 365 nm; 6mm LED Lens.....	91	1871879	Cleaning Kit for 75µm Nozzle.....	54
1538499	LOCTITE™ EQ CL10 6 mm LED Head 2.7 m.....	91, 101	1871880	125µm Nozzle Plate.....	54
1544934	LOCTITE® 30 ml Manual Syringe Applicator.....	31, 33	1872279	75µm Nozzle Plate.....	54
1562190	Sensor Extension Cord.....	25	1872538	O-Ring, 10 pack.....	54
1569523	LOCTITE® Robot Needle Calibration Kit.....	75, 76, 79	1874363	Heater Repair Kit.....	54
1573130	LOCTITE® 200/400 ml 1:1 Square Mix Nozzle.....	67	1874364	Air Cylinder Repair Kit.....	54
1573131	LOCTITE® 200/400 ml 1:1 Mix Nozzle.....	67	8900494	LOCTITE® Replacement Battery Kit.....	82
1573132	LOCTITE® 200/400 ml 1:1 Square Mix Nozzle.....	67	8900550	LOCTITE® PLC Interface Cable.....	17, 80, 83, 84, 85, 86
1573133	LOCTITE® 200/400 ml 1:1 Square Mix Nozzle.....	67	8965008	LOCTITE® Pressure Sensor and Cable for Dispense Valve Interface.....	62
1573134	LOCTITE® 200/400 ml 1:1 Square Mix Nozzle.....	67			
1573135	LOCTITE® 200/400 ml 1:1 Mix Nozzle.....	67			
1573136	LOCTITE® 200/400 ml 1:1 Mix Nozzle.....	67			
1573138	LOCTITE® 200/400 ml 1:1 Mix Nozzle.....	67			
1573139	LOCTITE® 200/400 ml 1:1 Square Mix Nozzle.....	67			
1573140	LOCTITE® 200/400 ml 1:1 Square Mix Nozzle.....	67			

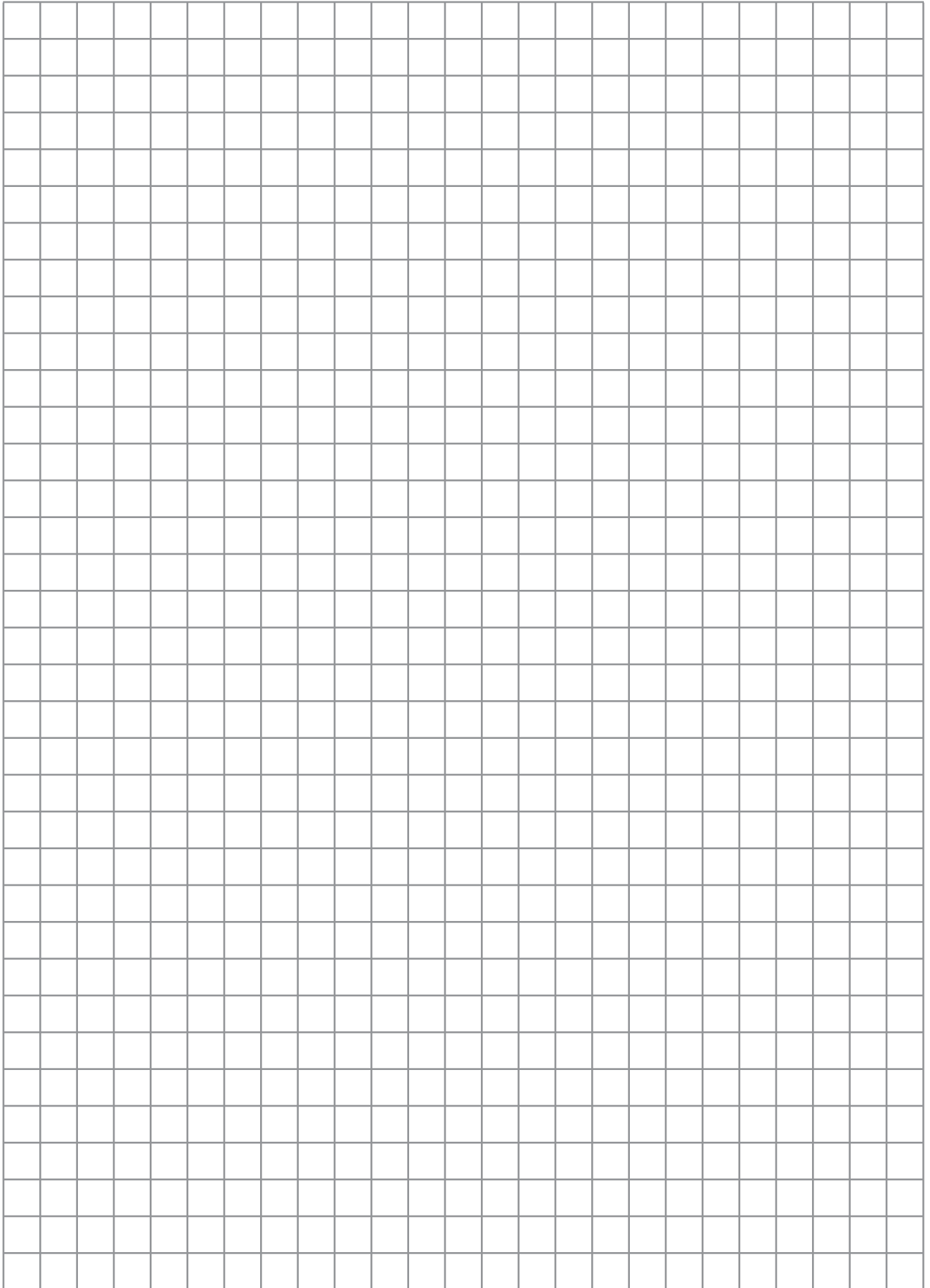

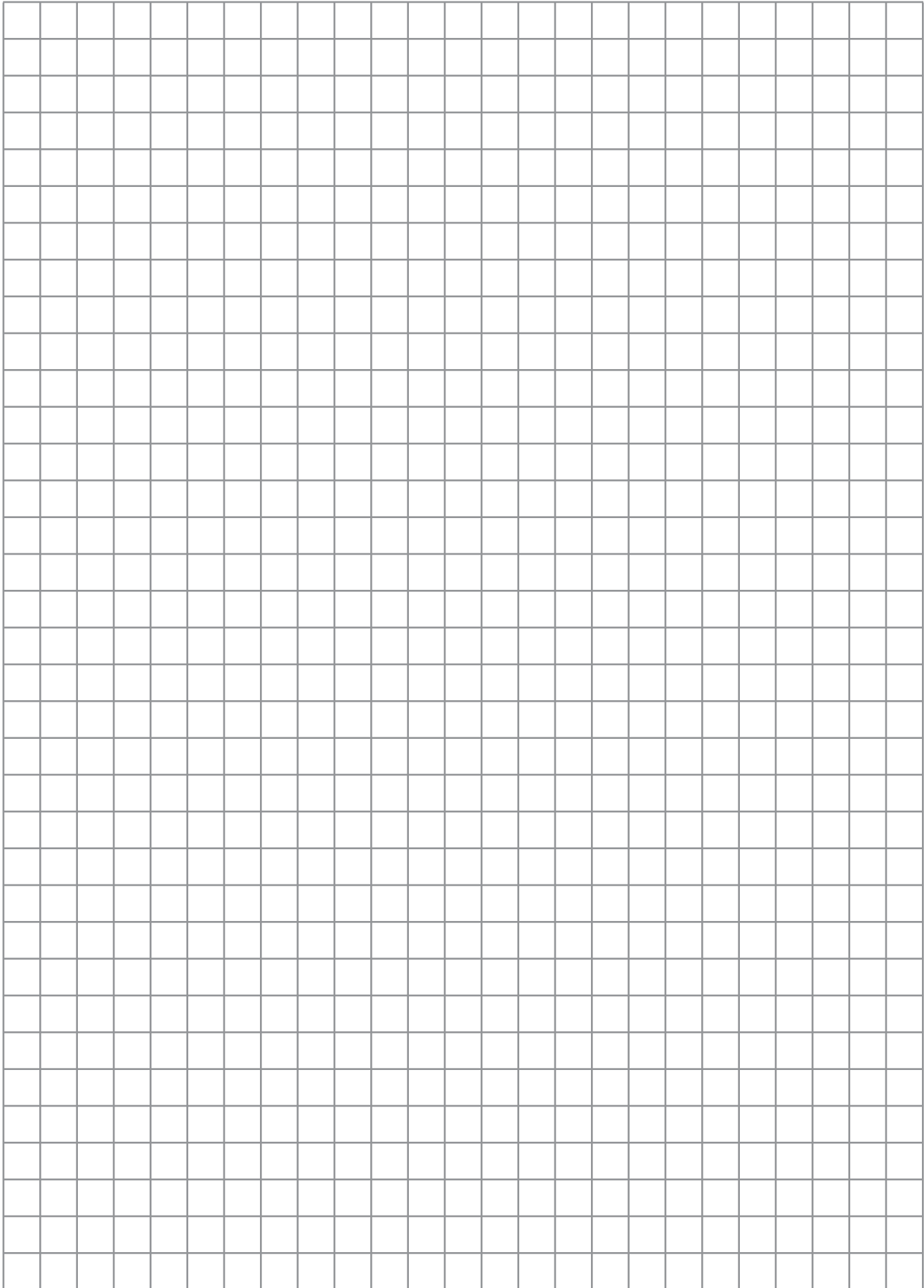



The Equipment Sourcebook 2014 – Volume 10

Visit us on the web at
www.equipment.loctite.com
for additional information,
diagrams, products and
our full line of equipment.

Visit us on the web at
www.henkelna.com/loctite
for immediate access to:

- Distributor Information
- Material Safety Data Sheets
- Technical Data Sheets
- Product Application Assistance
- Literature and our NEW e-Catalog

LOCTITE® is the
preferred choice
for high performance
adhesive and sealant
solutions for industrial
manufacturing
and maintenance.

Henkel Corporation

Engineering Adhesives

One Henkel Way

Rocky Hill, CT 06067

U.S.A.

www.henkelna.com/industrial

www.henkelna.com/loctite

U.S.A.

For your local LOCTITE® Adhesive and Sealant Specialist, the nearest authorized LOCTITE® product distributor, to place an order, to arrange an in-plant seminar or for technical product assistance, call: 1.800.LOCTITE (562.8483).

HENKEL CORPORATION

Engineering Adhesives
One Henkel Way
Rocky Hill, Connecticut 06067
Tel: 860.571.5100
Fax: 860.571.5465
www.henkelna.com/industrial
www.henkelna.com/loctite

CANADA

For your local LOCTITE® Adhesive and Sealant Specialist, for your nearest authorized LOCTITE® product distributor, to place an order, to arrange an in-plant seminar, or for technical product assistance, call: 1.800.263.5043 (within Canada).

HENKEL CANADA CORPORATION

2515 Meadowpine Blvd.
Mississauga, Ontario, Canada L5N 6C3
Tel: 1.800.263.5043 (within Canada)
Tel: 905.814.6511
Fax: 905.814.5391
www.loctite.ca

MEXICO & CENTRAL AMERICA

For your local LOCTITE® Adhesive and Sealant Specialist, for your nearest authorized LOCTITE® product distributor, to place an order, to arrange an in-plant seminar or for technical product assistance, call: 01.800.436.5357 (within Mexico); 506.2277.4868 (within Costa Rica).

HENKEL CAPITAL, S.A. DE C.V. (MEXICO)

Boulevard Magnocentro No. 8 Piso 2
Central Urbano Interlomas
52760 Huixquilucan, Estado de México
Technical Product Assistance: Tel: 52.55.3300.3669
To place an order: Tel: 52.55.3300.3644
Fax: 52.55.3300.3019
www.loctite.com.mx

HENKEL COSTA RICA LTDA.

De la Lovable, 100m Sur/50m Oeste
San Joaquín de Flores
Heredia, Costa Rica
Tel: 506.2277.4868 (within Costa Rica)
Tel: 506.2277.4800
Fax: 506.2277.4883
www.loctite.com.mx

SOUTH AMERICA

For your local LOCTITE® Adhesive and Sealant Specialist, for your nearest authorized LOCTITE® product distributor, to place an order, to arrange an in-plant seminar, or for technical product assistance, contact:

HENKEL LTDA. (BRAZIL)

Rua Karl Huller, 136 -
Jd. Canhema, Diadema
São Paulo, Brasil 09941-410
Tel: 0800.704.2334 (within Brazil)
Tel: 55.11.3205.8955
Fax: 55.11.3205.8887
www.loctite.com.br

HENKEL ARGENTINA S.A.

Nicola's Avellaneda 1357
(BI642EYA) San Isidro
Buenos Aires, Argentina
Tel: 0800.888.0213 (within Argentina)
Tel: 54.11.4001.0100
Fax: 54.11.4001.0158
www.loctite.com.ar

HENKEL CHILE LTDA.

Av. Laguna Sur 9551
Pudahuel
Santiago, Chile: C.P. 9060987
Tel: 800.223005 (within Chile)
Tel: 56.2.381.7200
Fax: 56.2.381.7811
www.loctite.cl

HENKEL COLOMBIANA S.A.

Calle 17 No. 68B-81
Bogotá D.C., Colombia
Tel: 01.800.01.14173 (within Colombia)
Tel: 571.423.9000
Fax: 571.425.1331
www.loctite.com.co

HENKEL VENEZOLANA S.A.

Zona Industrial Pruinca
Calle 2 Parcela 31 y 32
Guacara – Edo Carabobo, Venezuela
Tel: 0.800.10.07714 (within Venezuela)
Tel: 5824.5.560.2611
Fax: 5824.5.560.2660
www.loctite.com.ve