

# Keysight Technologies

## Accessories Selection Guide

### For Impedance Measurements

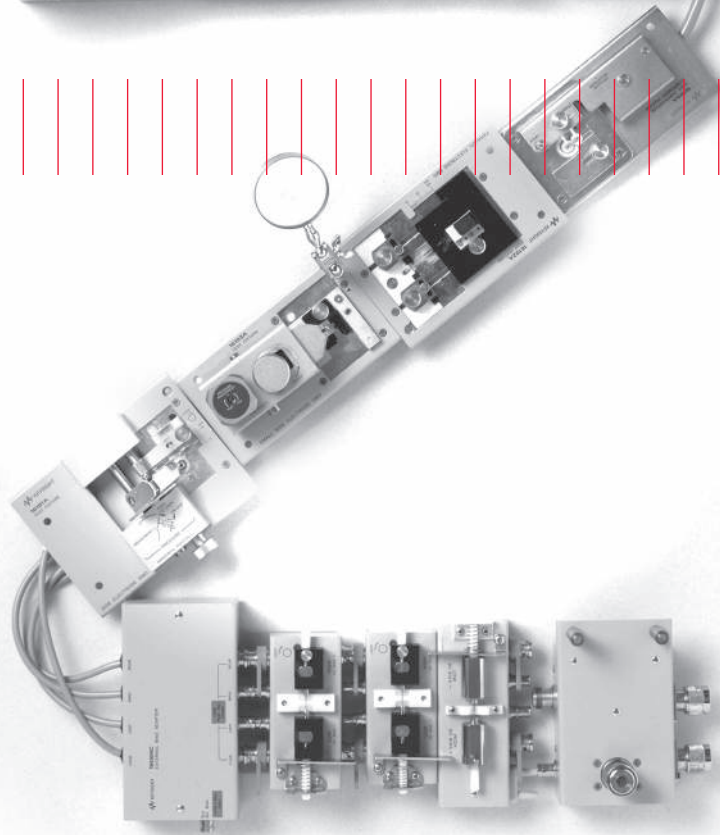

Selection Guide

# Table of Contents

Introduction	1
1. What are Keysight Accessories?	1
2. Types of Accessories	1
3. The Benefits of Keysight Accessories	2
4. ISO 9000 Quality Management	2
Tips for Selecting Appropriate Accessories	3
1. Selection by Measurement Application	3
2. Compatibility with Measurement Instruments	3
3. Frequency, DC Bias, and Operating Temperature/Humidity	4
4. DUT (Device Under Test) Dimensions	4
5. Open & Short Repeatability and Proportional Error	4
6. Furnished Accessories	4
7. Terminal Adapters	5
Accessory Catalogue	6
Applicable Frequency Ranges	6
Accessories Organization	7
Up to 110 MHz (4-Terminal Pair)	8
Lead Components:	
16047A Test Fixture	9
16047E Test Fixture	10
16060A Transformer Test Fixture	11
SMD:	
16034E Test Fixture	12
16034G Test Fixture	13
16034H Test Fixture	14
16044A Test Fixture	15-16
16334A Tweezers Contact Test Fixture	17
Other Components (Varying in Size or Shape):	
16089A Large Kelvin Clip Leads	18
16089B Medium Kelvin Clip Leads	18
16089C Kelvin IC Clip Leads	19
16089D Kelvin Alligator Clip Leads	19
Port/Cable Extension:	
16048A Test Leads	20
16048D Test Leads	20
16048E Test Leads	21
16048G Test Leads	22
16048H Test Leads	22

# Table of Contents

Probes:		
	42941A Impedance Probe Kit	23
DC Bias Accessories:		
	16065A 200 Vdc External Voltage Bias Fixture	24
	16065C 40 Vdc External Voltage Bias Adapter	24
Material:		
	16451B Dielectric Test Fixture	25-28
	16452A Liquid Dielectric Test Fixture	29-30
Up to 3 GHz (7 mm)		31
Lead Components:		
	16092A Spring Clip Test Fixture	32
SMD:		
	16192A Parallel Electrode SMD Test Fixture	33-34
	16194A High Temperature Component Test Fixture	35-36
	16196A Parallel Electrode SMD Test Fixture	37-39
	16196B Parallel Electrode SMD Test Fixture	40-41
	16196C Parallel Electrode SMD Test Fixture	42-43
	16196D Parallel Electrode SMD Test Fixture	44-45
	16197A Bottom Electrode SMD Test Fixture	46-48
DC Bias Accessories:		
	16200B External DC Bias Adapter	49
Material:		
	16453A Dielectric Material Test Fixture	50
	16454A Magnetic Material Test Fixture	51-52
DC (High Resistance)		53
SMD & Lead Components:		
	16339A Component Test Fixture	54
SMD:		
	16118A Tweezers Test Fixture	55

Other Components (Varying in Size, Shape or Grounded):		
	16117B Low Noise Test Leads	56
	16117C Low Noise Test Leads	57
Material:		
	16008B Resistivity Cell	58-59
Other Accessories		
	16190B Performance Test Kit	60
	16380A Standard Capacitor Set	61
	16380C Standard Capacitor Set	62
	42030A Four-Terminal Pair Standard Resistor Set	63
	42090A Open Termination	64
	42091A Short Termination	64
Appendix		
	The Concept of a Test Fixture's Additional Error	65
	1. System Configuration for Impedance Measurement	65
	2. Measurement System Accuracy	65-67
	3. New Market Trends and the Additional Error for Test Fixtures	67-70
	Error Compensation	71
	1. Open/short Compensation	71
	2. Open/short/load Compensation	71
	3. Electrical Length Compensation	72
	4. Cable Length Compensation	73
	Measurement Repeatability	73
Index		74
	Test Fixture Selection By SMD Size	75
	Accessories vs. Instruments Matrix	76
Keysight Web Resources	77	

# Introduction

When a device under test (DUT) is measured, a test fixture must be used to connect the instrument to the DUT. A test fixture is an interface specifically designed to connect the instrument and the contact tips of the DUT.

## 1. What are Keysight Technologies Accessories?

Keysight Technologies offers a variety of accessories suitable for many applications. They are designed to make measurements simple and reliable. For example, a mechanically and electrically precise test fixture is required to measure the impedance of SMD components. For this measurement, Keysight offers dedicated SMD fixtures for impedance measurement instruments that minimize the measurement errors. Also, specially designed fixtures for other specific applications (such as DC bias test, dielectric material test, and others.) are available. Keysight accessories facilitate a shorter time-to-market with increased confidence by providing accurate and repeatable measurements.

## 2. Types of Accessories

Keysight accessories can be divided into the following five categories:

### Test Fixtures

A test fixture is used to hold the electronic components or materials (physically and electrically) for the measurements. Keysight offers various kinds of 4-Terminal Pair test fixtures and 7 mm test fixtures. Some of them connect directly to the measurement instrument, while others require adapters.

### Test Leads

Test leads are used to extend the measurement ports from the UNKNOWN terminals of the instrument to the DUT. Using a flexible test lead, a DUT that cannot be held with test fixtures can be measured regardless of its size or shape. The test leads can also be used as cable extensions when the test sample is located away from the measurement instrument.

### Probes

Probes are helpful in measuring components which are already connected to PC boards or have one terminal grounded.

### Adapters

Adapters are used to adapt the dedicated circuits between the instrument and the test fixtures. The 42942A is a terminal conversion adapter that can convert a 4-Terminal Pair configuration to a 7 mm configuration. The 16065C is an external DC bias adapter that can apply DC bias to the DUT from an external DC bias source.

### Others

Also available are DC bias accessories and performance test equipment.

# Introduction

## 3. The Benefits of Keysight Accessories

Each accessory is designed to ensure highly accurate measurements without degrading the performance of the measurement instrument.

- Minimum residual error preserves the accuracy of the measurement instruments.
- Clearly defined error compensation allows easy calculation of error corrections.
- Strict measurement specifications, such as test frequencies and signal levels provide safe and accurate measurements.

This document introduces a group of Keysight accessories that are well suited for the following measurement instruments:

### LCR Meters:

- 4263B 100 Hz/120 Hz/1 kHz/10 kHz/100 kHz LCR Meter –
- 4284A\* 20 Hz - 1 MHz Precision LCR Meter
- E4980A 20 Hz - 2 MHz Precision LCR Meter
- 4285A 75 kHz - 30 MHz Precision LCR Meter
- 4287A\* 1 MHz - 3 GHz RF LCR Meter
- E4982A 1 MHz - 3 GHz LCR Meter

### Capacitance Meters

- 4268A\* 120 Hz/1 kHz Capacitance Meter
- 4279A\* 1 MHz C-V Meter
- 4288A\* 1 kHz/1 MHz Capacitance Meter
- E4981A Capacitance Meter

### Resistance Meters

- 4339B\* DC High Resistance Meter
- 4349B\* DC 4-ch High Resistance Meter

### Impedance Analyzers

- 4291B\* 1 MHz - 1.8 GHz RF Impedance/Material Analyzer
- 4294A 40 Hz - 110 MHz Precision Impedance Analyzer
- E4991A 1 MHz - 3 GHz RF Impedance/Material Analyzer

### Network Analyzer

- E5061B-3L5 LF-RF Network Analyzer

\* denotes the instrument is obsolete.

## 4. ISO 9000 Quality Management

ISO 9000 is a set of international standards for quality management and quality assurance. These standards were developed with the goal of documenting and implementing effective quality systems within companies. ISO standards are consistent with Keysight's quality system; in fact, the standards within Keysight Technologies' Quality Maturity System (QMS) exceed the intent of ISO 9000.

## Tips for Selecting Appropriate Accessories

The following topics comprise a helpful guideline for selecting an appropriate accessory for the measurement instrument to be used.

### 1. Selection by Measurement Application

Keysight accessories can be used in a wide variety of measurement applications. These applications range from basic measurements (such as impedance measurements for discrete devices) to advanced measurements (such as measurement of resistivities or dielectric constants.)

### 2. Compatibility with Measurement Instruments

Test fixtures/leads are compatible with the measurement instruments when they have the same type of terminal configuration and useable measurement frequency range. The measurement instruments described in this guide are divided into the following three categories based on frequency.

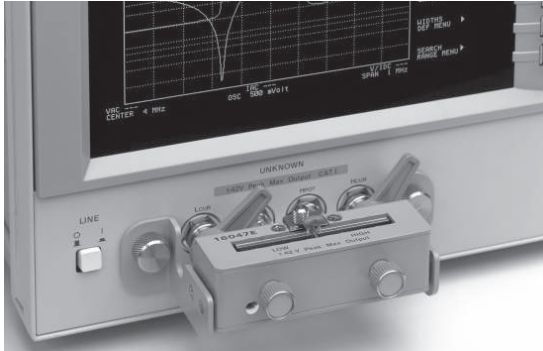
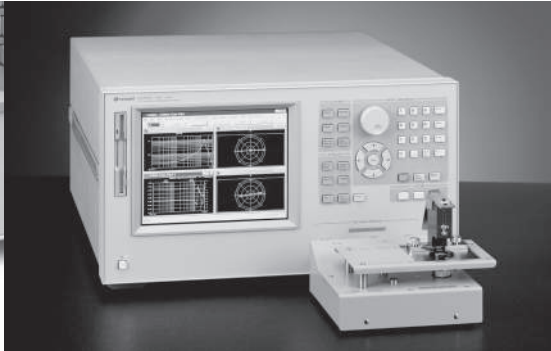
Frequency Range	Up to 110 MHz (Terminal Configuration: 4-Terminal Pair)	Up to 3 GHz (Terminal Configuration: 7 mm)
		
Measurement Instruments	4263B, 4268A, 4279A, 4284A, 4285A, 4288A, 4294A, E4980A, E4981A	4291B, 4294A + 42942A, E5061B-3L5 w/Opt. 005 + 16201A, 4287A, E4982A, E4991A Any 4TP instruments (excluding 4294A) + 16085B

Frequency	DC (High Resistance Measurement)
	
Measurement Instruments	4339B, 4349B

## Tips for Selecting Appropriate Accessories

### 3. Frequency, DC Bias, and Operating Temperature/Humidity

Each of the Keysight accessories has its own specific operating range. Any measurement performed outside this range can increase residual errors and can cause problems. Be sure that your measurement environment fits the accessory's specific operating range. In the case of humidity, Keysight's accessories can operate at a relative humidity of 95% or less at 40°C. (These same requirements apply to most LCR Meters and Impedance Analyzers.) When the ambient temperature is not approximately 40°C, use an accessory that has no condensation on its surface.

### 4. DUT (Device Under Test) Dimensions

The DUT can vary from chip components, axial/radial leads, or ICs to general electrical materials. Select a test fixture/lead that is suitable for the shape and size of your components or materials.

### 5. Open & Short Repeatability and Proportional Error

Since a test fixture induces an additional error when measuring, the total measurement error is the sum of the measurement instrument's measurement accuracy and the fixture's additional error. Generally, a test fixture's additional error consists of three terms: open repeatability, short repeatability and proportional error. Open and short repeatability exhibit the error factors of the open and short residual impedances which affect the measurements of extremely high and low impedances respectively. Proportional error exhibits the error factor, which is proportional to the value of the impedance being measured. For more details on this subject, please refer to the Appendix.

### 6. Furnished Accessories

Each test fixture is shipped with a manual and various other accessories needed for measuring. For example, the 42941A impedance probe kit is furnished with a pin probe, an adapter (BNC-SMB), 3 spare pins, a carrying case and an operation and service manual.



## Tips for Selecting Appropriate Accessories

### 7. Terminal Adapters

Terminal Adapters convert the instruments terminal configuration into a 7 mm terminal configuration. This means that instruments that do not have a 7 mm terminal connector can use test fixtures with a 7 mm terminal connector. The 42942A converts a 4-Terminal Pair configuration into a 7 mm terminal connector, which can only be used with the 4294A.

#### 42942A Terminal Adapter



**Dimensions (approx.):** 190(W) x 55(H) x 140 (D) [mm]

**Weight (approx.):** 800 g

**Applicable Instrument:** 4294A

**Frequency:** 40 Hz to 110 MHz

**Maximum Voltage:**  $\pm 42$  V peak max. (AC +DC)

**Operating Temperature:** 0°C to 40°C

**Furnished Accessories:**

Description	P/N	Qty.
Carrying Case	42942-60011	1
Operation and Service Manual	42942-90020	1

**Options:**

42942A-700: Add 7mm open/short/load set

Description	P/N	Qty.
Open Termination	04191-85302	1
Short Termination	04191-85300	1
Load Termination	04291-60043	1

# Accessories Catalogue

## Applicable Frequency Ranges

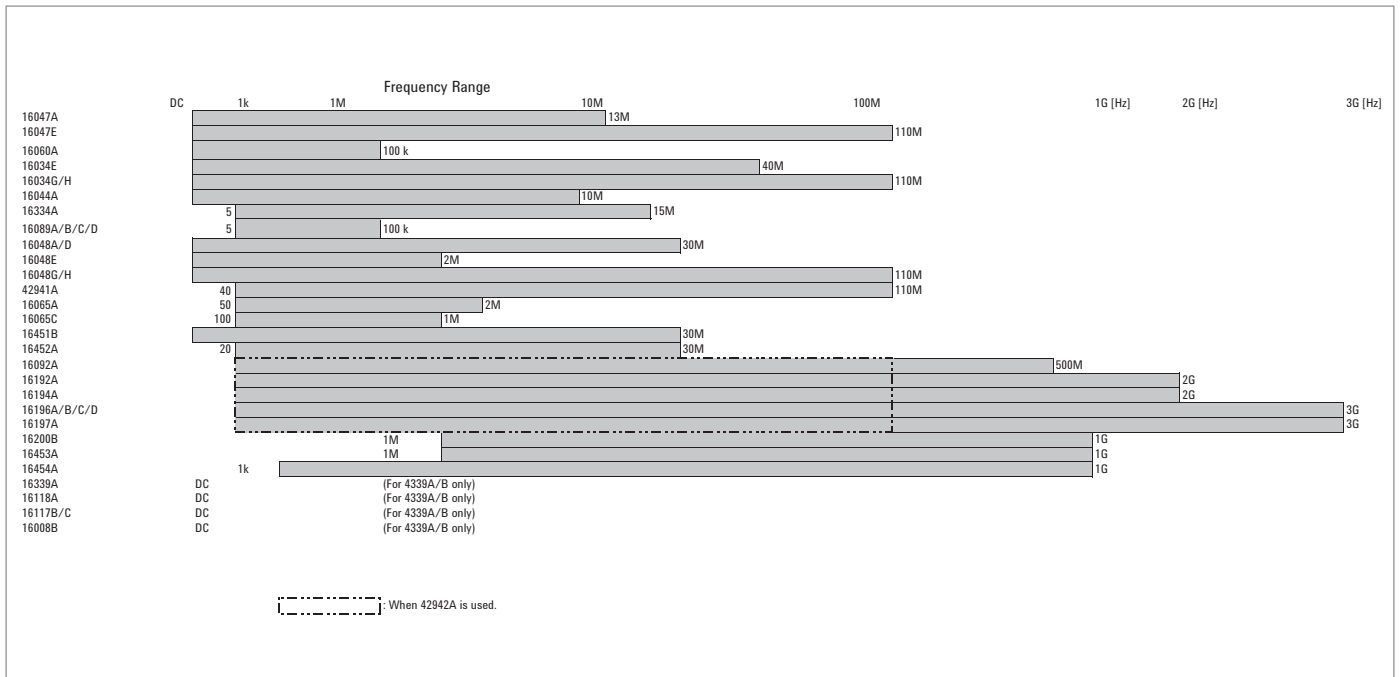

# Accessories Catalogue

## Accessories Organization

This document is organized by measurement frequency and DUT to enable quick selection of an appropriate test fixture for a particular measurement application. The following tables show the various categories in each primary group:

### Up to 110 MHz (Terminal Configuration: 4-Terminal Pair)

Lead components	16047A/E, 16060A
SMD components	16034E/G/H, 16044A, 16334A
Other components	16089A/B/C/D
Port/Cable extension	16048A/D/E/G/H
DC bias accessories	16065A/C
Material	16451B, 16452A

### Up to 3 GHz (Terminal Configuration: 7 mm Connector)

Lead components	16092A,16194A
SMD components	16092A, 16192A, 16194A, 16196A/B/C/D, 16197A
DC bias accessories	16200B
Material	16453A, 16454A

### DC (High Resistance Measurement)

Lead components	16339A
SMD components	16118A, 16339A
Other components	16117B/C
Material	16008B

### Other Accessories

Miscellaneous	16190B, 16380A/C, 42060A, 42090/1A
---------------	------------------------------------

# Up to 110 MHz (4-Terminal Pair)

Test Fixtures (4-Terminal Pair) for Impedance Measurements up to 110 MHz

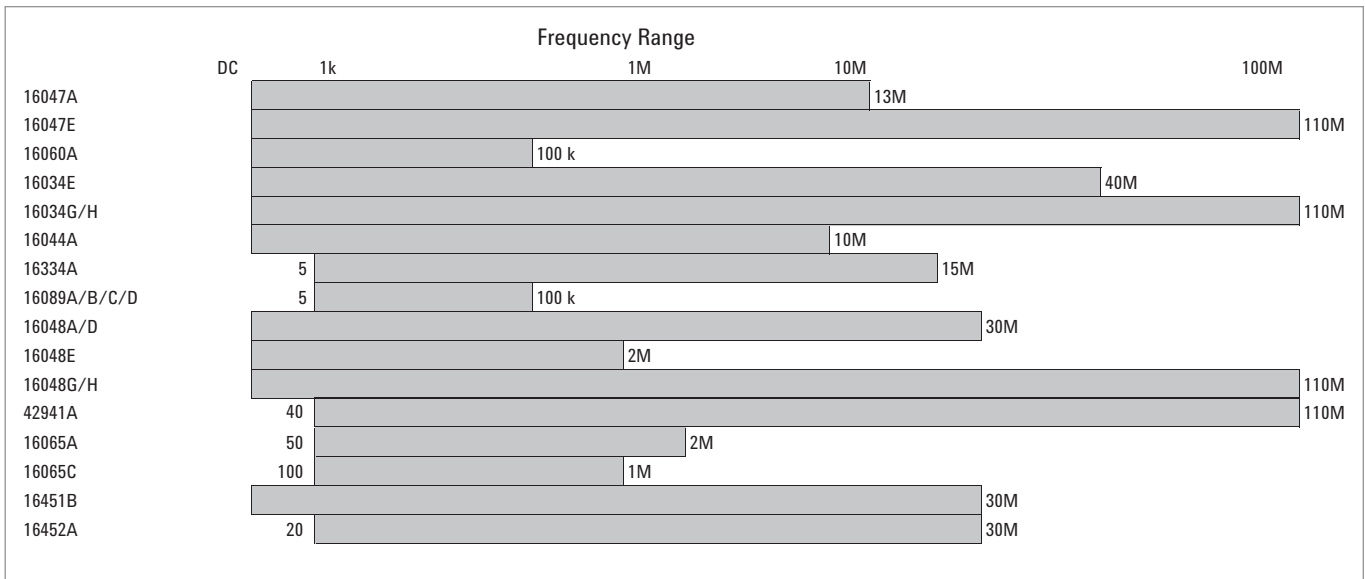

## Applicable Instrument

Frequency Range	Up to 110 MHz (Terminal Configuration: 4-Terminal Pair)	Up to 3 GHz (Terminal Configuration: 7 mm)
Measurement Instruments	4263B, 4268A, 4279A, 4284A, 4285A, 4288A, 4294A, E4980A, E4981A	4291B, 4294A + 42942A, E5061B-3L5 w/Opt. 005 + 16201A, 4287A, E4982A, E4991A Any 4TP instruments (excluding 4294A) + 16085B

Frequency	DC (High Resistance Measurement)
Measurement Instruments	4339B, 4349B

# Up to 110 MHz (4-Terminal Pair) Lead Components

## 16047A Test Fixture

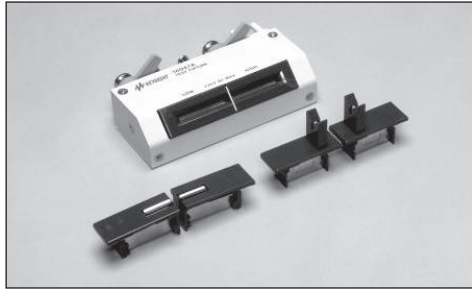

**Terminal Connector:** 4-Terminal Pair, BNC

**DUT Connection:** 4-Terminal

**Dimensions (approx.):**

124 (W) x 31 (H) x 62 (D) mm

**Weight (approx.):** 205 g

**Additional Error:**

Type of Error	Impedance
Proportional Error	$\pm 5 \times (f/10)^2$

f: [MHz]

**Description:** This test fixture is designed for impedance evaluation of axial/radial lead type devices. The 16047A employs Kelvin contacts which realize a wide impedance measurement range. The contact tip can be changed according to the device shape.

**Applicable Instruments:** 4263B, 4268A\*, 4279A\*, 4288A\*, E4980A, E4981A, (4284A\*, 4285A, 4294A)\*\*

\* denotes the instrument is obsolete.

\*\* applicable in a limited frequency range.

**Frequency:** DC to 13 MHz

**Maximum Voltage:**  $\pm 42$  V peak max. (AC+DC)

**Operating Temperature:** 0°C to 55°C

**DUT Size:** See figure with module sizes.

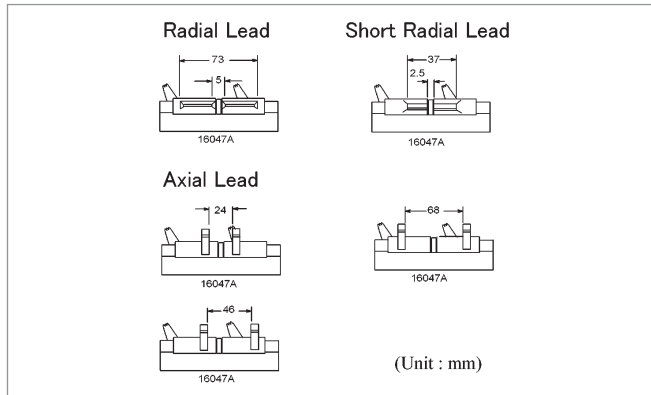

16047A module sizes

### Furnished Accessories:

Description	P/N	Qty.
Module For Axial Lead	16061-70022	2
Module For Radial Lead mounting on fixture	16061-70021	2
Module For Short Radial Lead	16047-65001	2
Operating Note	16047-90011	1

Each module size for the 16047A is shown above.

### Option:

16047A-701: Add Shorting Plate P/N 16047-00640

**Compensation and Measurement:** Select one of these modules suitable for the DUT's shape. Open and short compensations are recommended before measurement. Short compensation is performed by shorting the contacts of the test fixture with a shorting plate. After performing open and short compensations, the DUT is connected to the test fixture.

### P/N 16047-00640

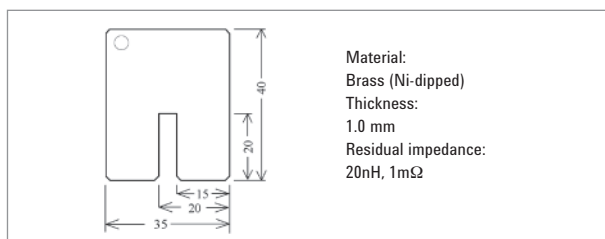

Shorting plate

## Up to 110 MHz (4-Terminal Pair) Lead Components

### 16047E Test Fixture

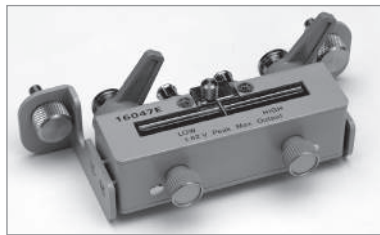

**Terminal Connector:** 4-Terminal Pair, BNC

**DUT Connection:** 2-Terminal

**Dimensions (approx.):**

135 (W) x 40 (H) x 65 (D) [mm]

**Weight (approx.):** 200 g

**Additional Error:**

Type of Error	Impedance
Proportional Error $f \leq 15$ MHz	$0.2 \times (f/10)^2$ [%]
Proportional Error $f > 15$ MHz	$4 \times (f/100)$ [%]
Open Repeatability	$2n + 10 \mu \times (f/100)$ [S]
Short Repeatability	$2m + 600 m \times (f/100)$ [ $\Omega$ ]

f: [MHz]

**Description:** This test fixture is designed for impedance evaluation of lead type devices up to 110 MHz. A guard terminal is available for three terminal devices and a shorting plate comes secured on this fixture.

**Applicable Instruments:** 4263B, 4268A\*, 4279A\*, 4284A\*, 4285A, 4288A\*, 4294A, E4980A, E4981A, E5061B-3L5 with Opt. E5061B-005

\* denotes the instrument is obsolete.

**Frequency:** DC to 110 MHz

**Maximum Voltage:**  $\pm 42$  V peak max.(AC+DC)

**Operating Temperature:**  $-20^\circ\text{C}$  to  $75^\circ\text{C}$

**DUT Size:** See figure below with 16047E's electrode size.

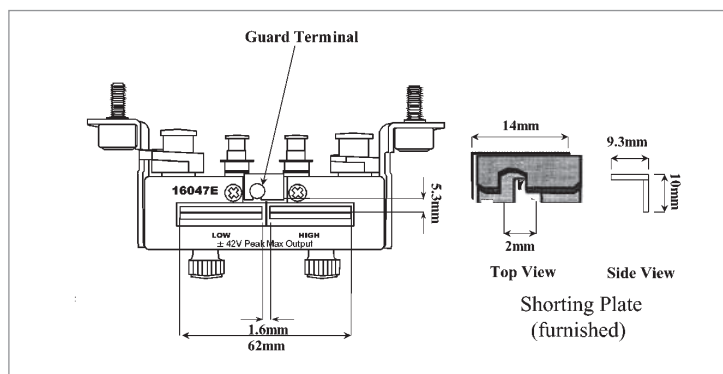

#### Furnished Accessories:

Description	P/N	Qty.
Angle (right-side)	16047-01221	1
Angle (left-side)	16047-01222	1
Screws	0515-1229	4
Shorting Plate	16047-00621	1
Operating and Service Manual	16047-90040	1

**Compensation and Measurement:** Open and short compensations are recommended before measurement. Short compensation is performed by shorting the contacts of the test fixture with a shorting plate. After performing open and short compensations, the DUT is connected to the test fixture. The following figures show how compensation and measurement are performed.

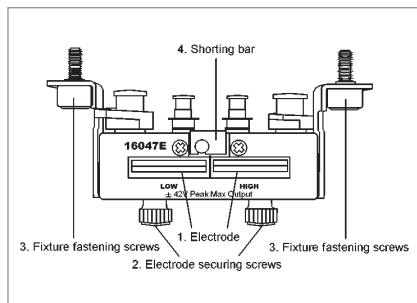

Test fixture overview

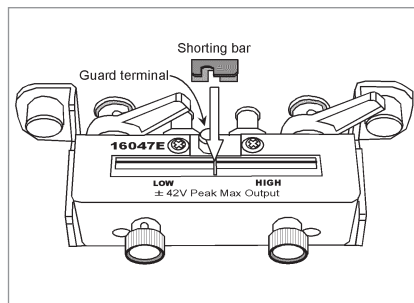

Connecting a shorting plate

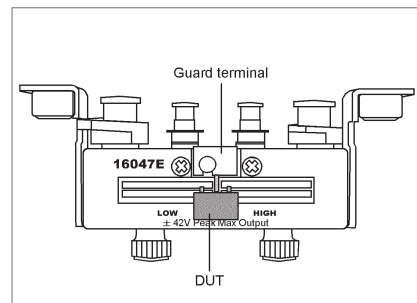

Measuring 3-Terminal device

# Up to 110 MHz (4-Terminal Pair) Lead Components

## 16060A Transformer Test Fixture



**Terminal Connector:** 4-Terminal Pair, BNC

**DUT Connection:**

2-Terminal for L measurement

3-Terminal for N, M measurement

See figure below for more information.

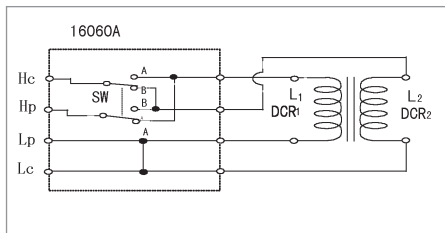

**Dimensions (approx.):**

90 (W) x 35 (H) x 90 (D) [mm]

**Cable Length (approx.):** 25cm

**Weight (approx.):** 300 g

**Additional Error:** The additional error is negligible when compared to the instrument's accuracy.

**Description:** This test fixture provides a convenient means of measuring a transformer's self-inductance, mutual inductance, turns-ratio, and DC resistance in the frequency range of DC to 100 kHz, as appropriate for each measurement.

**Applicable Instruments:** 4263B with Option 4263B-001

**Frequency:** DC to 100 kHz

**Operating Temperature:** 0°C to 55°C

**DUT Size:** The lead wire of the transformer should not have a diameter greater than 4 mm, otherwise the alligator clip will not be able to clamp onto it properly.

**Furnished Accessories:**

Description	P/N	Qty.
Test Leads (black), Alligator clip to BNC(m)	16060-61601	2
Test Leads (red), Alligator clip to BNC(m)	16060-61602	2
Operation and Service Manual	16060-90000	1

**Compensation and Measurement:** Open compensation is recommended before measurement. Open compensation is performed by connecting the alligator clips of "A" and "B" terminals together and separating them from the likewise connected alligator clips of the COMMON terminals. After performing open compensation, the transformer is connected to the test fixture. The "A" and "B" terminals are connected to the high terminals of the transformer. The COMMON terminals are connected to the low terminals of the transformer. The following figures show how compensation and measurement are performed.

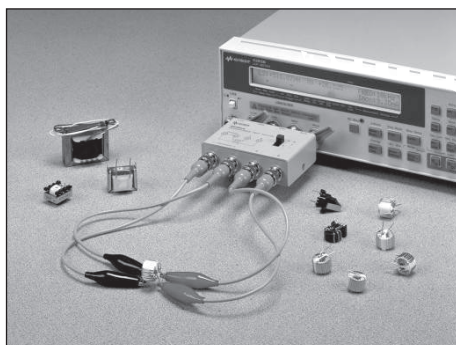

4263B with 16060A

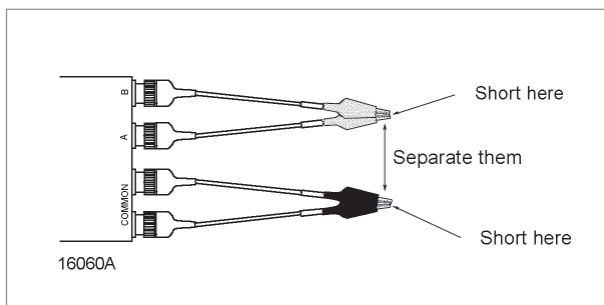

Open compensation

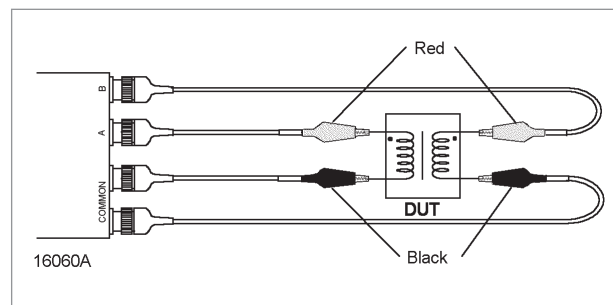

Connecting a transformer

# Up to 110 MHz (4-Terminal Pair) SMD

## 16034E Test Fixture

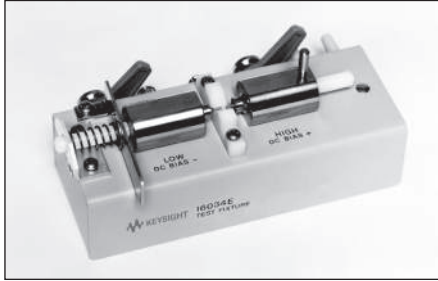

**Terminal Connector:** 4-Terminal Pair, BNC

**DUT Connection:** 2-Terminal

**Dimensions (approx.):**

128 (W) x 60 (H) x 71 (D) [mm]

**Weight (approx.):** 270 g

**Additional Error:**

Type of Error	Impedance
Proportional Error	$\pm 1.5 \times (f/10)^2$

f: [MHz]

**Description:** This test fixture is designed for impedance evaluations of SMD. The minimum SMD size that this fixture is adapted to evaluate is 1.6(L) x 0.8(W) [mm].

**Applicable Instruments:** 4263B, 4268A\*, 4279A\*, 4284A\*, 4285A, 4288A\*, E4980A, E4981A, E5061B-3L5 with Opt. E5061B-005 (4294A)\*\*

\* denotes the instrument is obsolete.

\*\* applicable in a limited frequency range.

**Frequency:** DC to 40 MHz

**Maximum Voltage:**  $\pm 42$  V peak max. (AC+DC)

**Operating Temperature:** 0°C to 55°C

**DUT Size:** See figure below

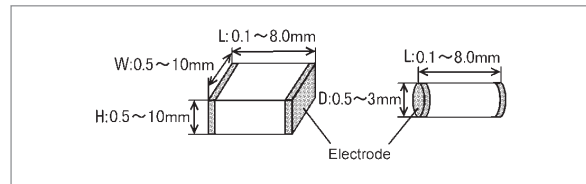

### Furnished Accessories:

Description	P/N	Qty.
Operating Manual	16034-90041	1

**Compensation and Measurement:** Open and short compensations are recommended before measurement. Open compensation is performed by separating the high and low electrodes from each other. The separation should be equivalent in size to the DUT's width. Short compensation is performed by contacting the high and low electrodes together. After performing open and short compensations, the DUT is inserted into the test fixture. The following figures show how compensation and measurement are performed.

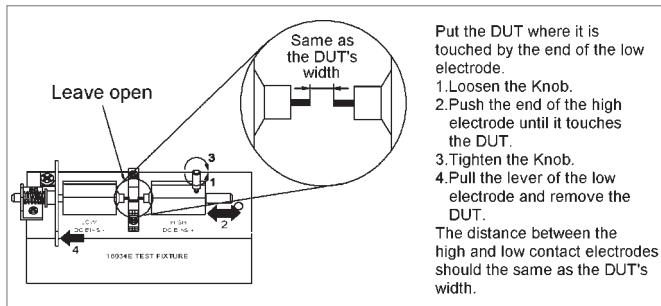

Open compensation

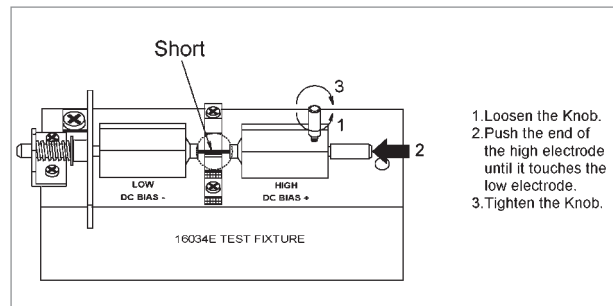

Short compensation

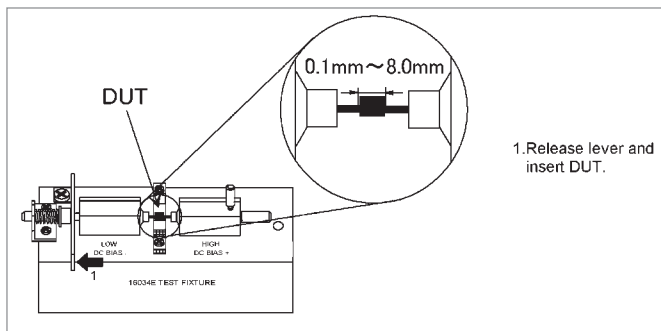

Inserting a DUT

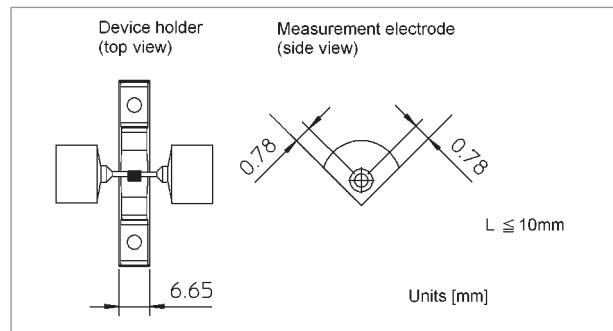

Electrode dimensions



# Up to 110 MHz (4-Terminal Pair) SMD

## 16034G Test Fixture

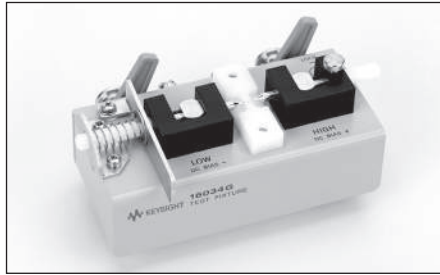

**Terminal Connector:** 4-Terminal Pair, BNC

**DUT Connection:** 2-Terminal

**Dimensions (approx.):**

120(W) x 50(H) x 70(D) [mm]

**Weight (approx.):** 200 g

**Additional Error:**

Type of Error	Impedance
Proportional Error	$0.5 \times (f/10)^2$ [%]
Open Repeatability	$5 + 500 \times (f/10)$ [nS]
Short Repeatability	$10 + 13 \times (f/10)$ [mΩ]

f: [MHz]



4284A with 16034G

**Description:** This test fixture is designed for impedance evaluations of SMD. The minimum SMD size that this fixture is adapted to evaluate is 0.6(L) x 0.3(W) [mm].

**Applicable Instruments:** 4263B, 4268A\*, 4279A\*, 4284A\*, 4285A, 4288A\*, 4294A, E4980A, E4981A, E50613-3L5 with Opt. E5061B-005

\* denotes the instrument is obsolete.

**Frequency:** DC to 110 MHz

**Maximum Voltage:** ±42 V peak max. (AC+DC)

**Operating Temperature:** 0°C to 55°C

**DUT Size:** See figure below

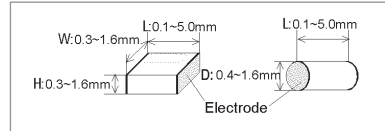

### Furnished Accessories:

Description	P/N	Qty.
Case for 100 Ω SMD Resistance	1540-0692	1
100Ω Chip Resistor	0699-2488	10
Operating Manual	16034-90011	1

**Compensation and Measurement:** Open and short compensations are recommended before measurement. When measuring above 3 MHz, load compensation is also recommended. Open compensation is performed by separating the high and the low electrodes from each other. The separation size should be equivalent to the DUT's width. Short compensation is performed placing the high and low electrodes in contact together. Load compensation is performed by using the furnished 100 Ω SMD chip resistor. After performing open, short and load compensations, the DUT is inserted into the test fixture. The following figures show how compensation and measurement are performed.

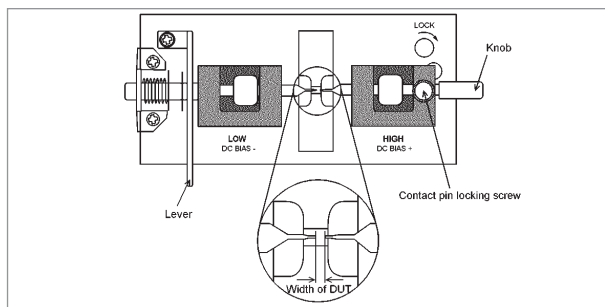

Open compensation

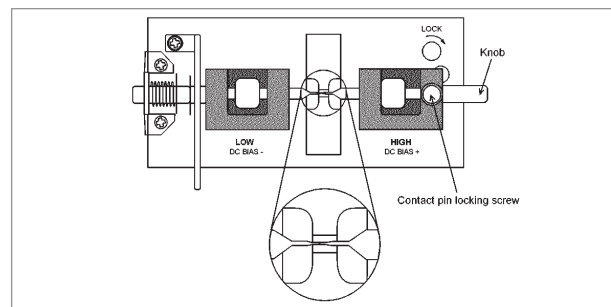

Short compensation

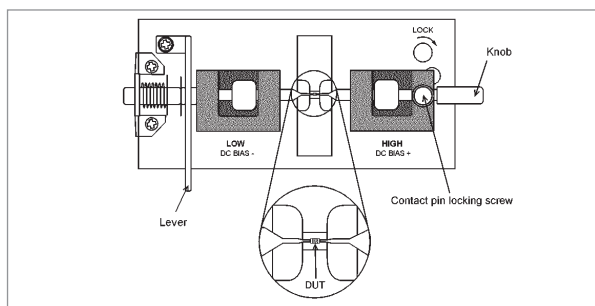

DUT measurement

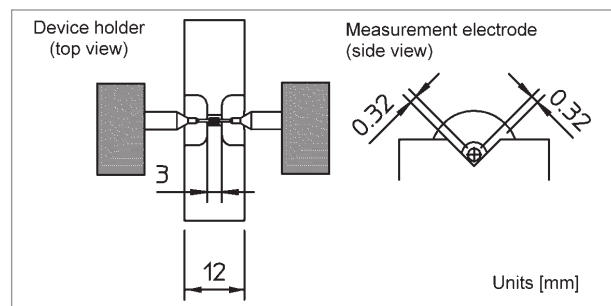

Dimensions

## Up to 110 MHz (4-Terminal Pair) SMD

### 16034H Test Fixture

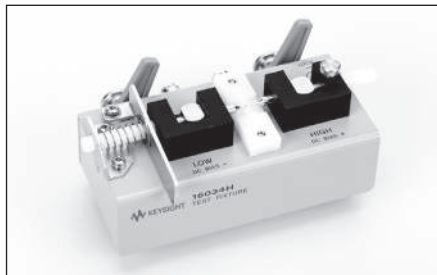

**Terminal Connector:** 4-Terminal Pair, BNC

**DUT Connection:** 2-Terminal

**Dimensions (approx.):**

120(W) x 50(H) x 70(D) [mm]

**Weight (approx.):** 200 g

**Additional Error:**

Type of Error	Impedance
Proportional Error	$0.5 \times (f/10)^2$ [%]
Open Repeatability	$5 + 500 \times (f/10)$ [nS]
Short Repeatability	$10 + 13 \times (f/10)$ [mΩ]

f: [MHz]

**Description:** This test fixture is designed for impedance evaluations of array-type SMD. The minimum SMD size that this fixture is adapted to evaluate is 1.6(L) x 0.8(W) [mm]. Since the tip of the measurement electrodes are very thin and the device holder is extremely flat, the device can be shifted and the measurement electrodes can contact the each elements of the array-type component.

**Applicable Instruments:** 4263B, 4268A\*, 4279A\*, 4284A\*, 4285A, 4288A\*, 4294A, E4980A, E4981A, E5061B-3L5 with Opt. E5061B-005

\* denotes the instrument is obsolete.

**Frequency:** DC to 110 MHz

**Maximum Voltage:** ±42 V peak max. (AC+DC)

**Operating Temperature:** 0°C to 55°C

**DUT Size:** See figure below

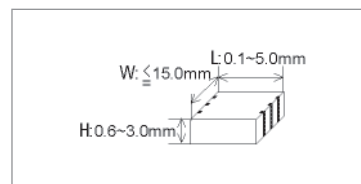

#### Furnished Accessories:

Description	P/N	Qty.
Case for 100 Ω SMD Resistance	1540-0692	1
100Ω Chip Resistor	0699-2488	10
Operating Manual	16034-90012	1

**Compensation and Measurement:** Open and short compensations are recommended before measurement. When measuring above 3 MHz, load compensation is also recommended. Open compensation is performed by separating the high and the low electrodes from each other. The separation should be equivalent in size to the DUT's width. Short compensation is performed by placing the high and low electrodes in contact together. Load compensation is performed by using the furnished 100 Ω SMD chip resistor. After performing open, short and load compensations, the DUT is inserted into the test fixture. Refer to the 16034G figures to see how compensation and measurement are performed.

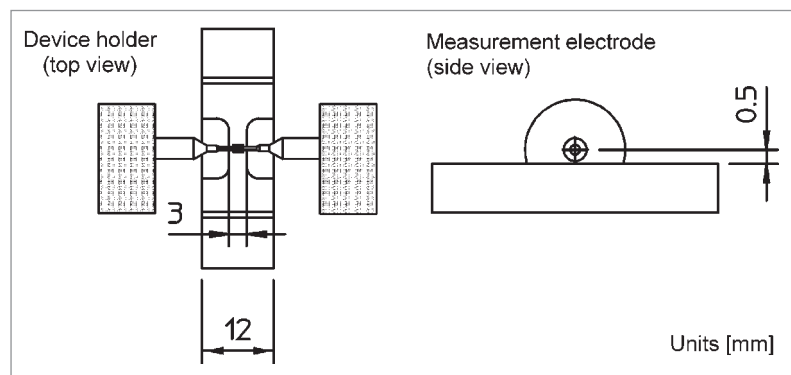

Electrode dimensions

## Up to 110 MHz (4-Terminal Pair) SMD

### 16044A Test Fixture

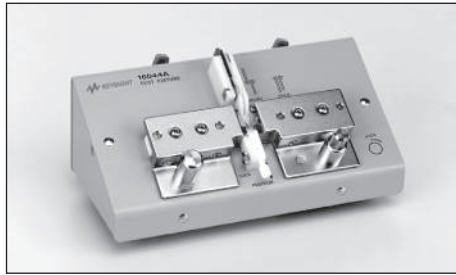

**Terminal Connector:** 4-Terminal Pair, BNC

**DUT Connection:** 4-Terminal

**Dimensions (approx.):**

160(W) x 70(H) x 98(D) [mm]

**Weight (approx.):** 550 g

**Additional Error:**

Type of Error	Impedance
Proportional Error	$2 \times (f/10)^2$ [%]
Open Repeatability	$1.5 + 200 \times (f/10)$ [nS]
Short Repeatability	$1.5 + 40 \times (f/10)$ [mΩ]

f: [MHz]

**Description:** This test fixture is designed for impedance evaluations of low impedance SMD. The minimum SMD size that this fixture is adapted to evaluate is 1.6(L) x 0.8(W) [mm]. The 16044A has a Kelvin (4-Terminal) contact, which ensures repeatable measurements. It is also equipped with a mechanism for easily performing open and short compensation.

**Applicable Instruments:** 4263B, 4268A\*, 4279A\*, 4284A\*, 4288A\*, 4338B\*, E4980A, E4981A, (4285A, 4294A)\*\*

\* denotes the instrument is obsolete.

\*\* applicable in a limited frequency range.

**Frequency:** DC to 10 MHz

**Maximum Voltage:** ±40 V peak max (AC+DC)

**Operating Temperature:** 0 °C to 55 °C

**DUT Size:** See figure below

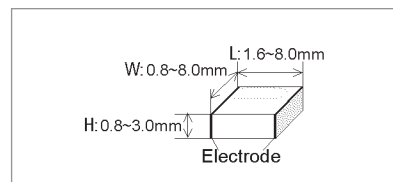

#### Furnished Accessories:

Description	P/N	Qty.
Cleaning Rod	5182-7586	1
Operating and Service Manual	16044-90020	1

To maintain the measurement precision, it is recommended that contact pins be replaced approximately every 50,000 times (supplementary value).

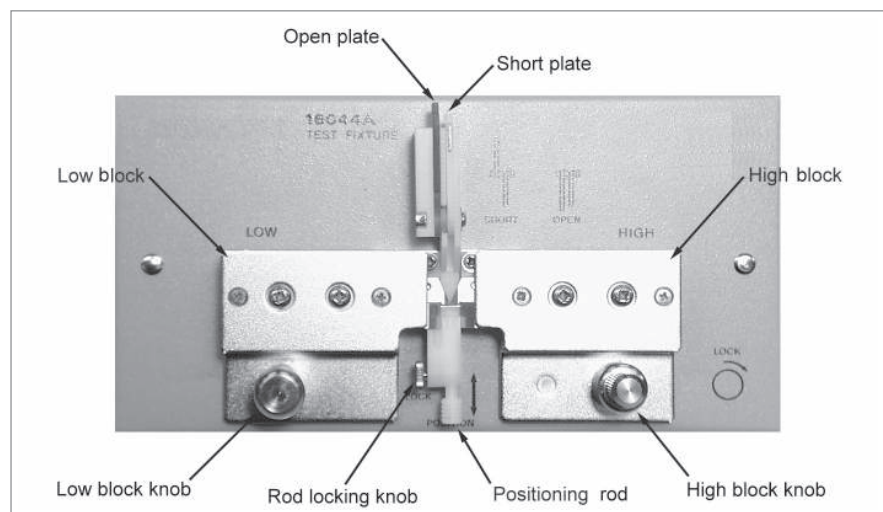

Test fixture overview

# Up to 110 MHz (4-Terminal Pair) SMD

**Compensation and Measurement:** Open and short compensations are recommended before measurement. Short compensation is performed by bringing down the shorting plate (which is already on the fixture) to short all 4 terminals. Open compensation is performed by bringing down both the open plate and the shorting plate to separate the high terminals from the low terminals. After performing open and short compensations, the DUT is inserted into the test fixture. The figures below show how compensation and measurement are performed.

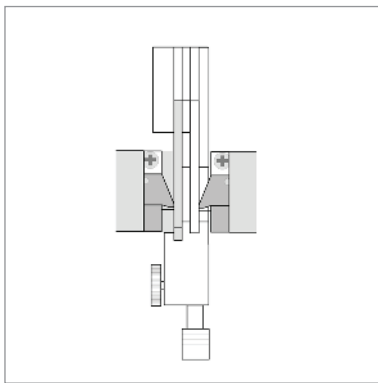

Open compensation

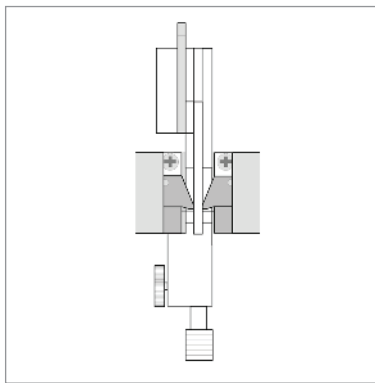

Short compensation

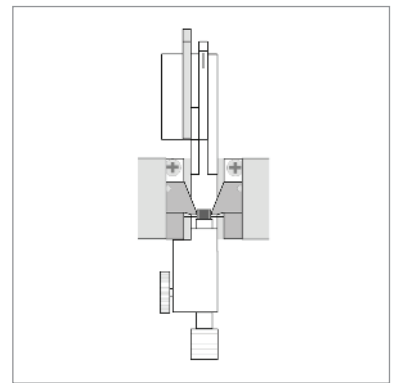

Inserting a DUT

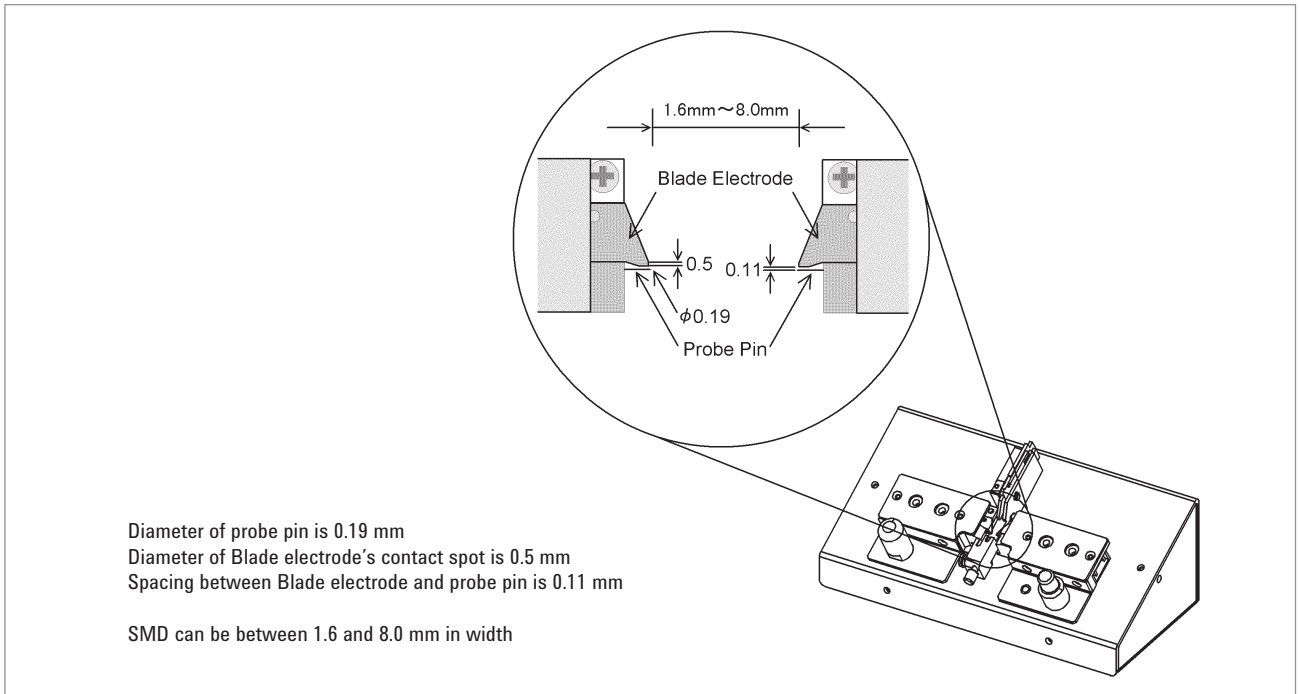

Electrode dimensions

## Up to 110 MHz (4-Terminal Pair) SMD

### 16334A Tweezers Contact Test Fixture

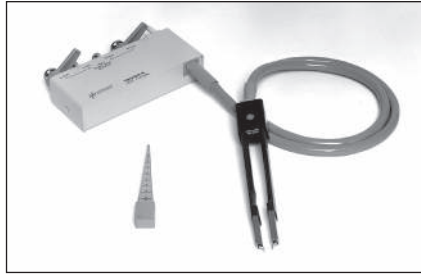

**Terminal Connector:** 4-Terminal Pair, BNC

**DUT Connection:** 2-Terminal

**Cable Length (approx.):** 1m (from BNC connectors to the top of tweezers)

**Weight (approx.):** 290 g

**Additional Error:**

Type of Error	Impedance
Proportional Error	$\pm 2 \times (f/10)^2$

f: [MHz]

**Description:** This test fixture is designed for impedance evaluations of SMD. The minimum SMD size that this fixture is adapted to evaluate is 1.6(L) x 0.8(W) [mm]. The tweezers' contacts on this fixture makes it easy to hold the DUT.

**Applicable Instruments:** 4263B, 4268A\*, 4279A\*, 4284A\*, 4288A\*, E4980A, E4981A, (4285A, 4294A)\*\*

\* denotes the instrument is obsolete.

\*\* applicable in a limited frequency range.

**Frequency:** 5 Hz to 15 MHz

**Maximum Voltage:**  $\pm 42$  V peak max. (AC+DC)

**Operating Temperature:** 0°C to 55°C

**DUT Size:**  $\leq 10$  mm (width)

See figure below

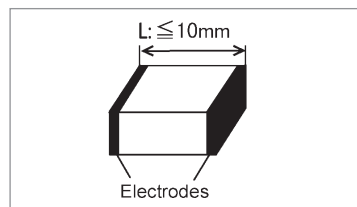

#### Furnished Accessories:

Description	P/N	Qty.
Compensation Block	16334-60001	1
Operating Note	16334-90000	1

**Compensation and Measurement:** Open and short compensations are recommended before measurement. Open and short compensations are performed by using the furnished compensation block. After performing open and short compensations, the DUT is sandwiched by the tweezers' contacts and is measured.

## Up to 110 MHz (4-Terminal Pair) Other Components

### 16089A Large Kelvin Clip Leads



**Terminal Connector:**

4-Terminal Pair, BNC

**DUT Connection:** 4-Terminal

**Cable Length (approx.):**

0.94m (from connector to clip's tip)

**Weight (approx.):** 300 g

**Additional Error:** The additional error is negligible when compared to the instrument's accuracy.

**Description:** This test fixture makes it possible to measure odd-shaped components that cannot be measured with conventional fixtures. It is equipped with two insulated Kelvin clips.

**Applicable Instruments:** 4263B, 4268A\*, (4284A\*, 4285A, 4288A\*, 4294A, E4980A, E4981A)\*\*

\* denotes the instrument is obsolete.

\*\* applicable in a limited frequency range.

**Frequency:** 5 Hz to 100 kHz

**Maximum Voltage:**  $\pm 42$  V peak max. (AC+DC)

**Operating Temperature:** 0°C to 55°C

**DUT Size:**

See figure below

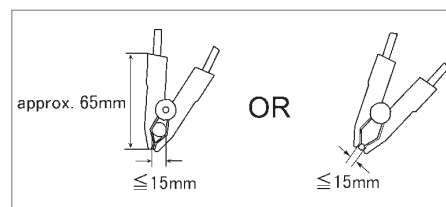

**Furnished Accessories:**

Description	P/N	Qty.
Operating and Service Manual	16089-90020	1

**Compensation and Measurement:** Open and short compensations are recommended before measurement. For open compensation, do not connect the Kelvin clips to anything. Short compensation is performed by holding a shorting plate with the Kelvin clips. After performing open and short compensations, the DUT is held with the Kelvin clips.

### 16089B Medium Kelvin Clip Leads



**Terminal Connector:** 4-Terminal Pair, BNC

**DUT Connection:** 4-Terminal

**Cable Length (approx.):**

0.94m (from connector to clip's tip)

**Weight (approx.):** 300 g

**Additional Error:** The additional error is negligible when compared to the instrument's accuracy.

**Description:** This test fixture makes it possible to measure odd-shaped components that cannot be measured with conventional fixtures. It is equipped with two insulated Kelvin clips.

**Applicable Instruments:** 4263B, 4268A\*, (4284A\*, 4285A, 4288A\*, 4294A, E4980A, E4981A)\*\*

\* denotes the instrument is obsolete.

\*\* applicable in a limited frequency range.

**Frequency:** 5 Hz to 100 kHz

**Maximum Voltage:**  $\pm 42$  V peak max. (AC+DC)

**Operating Temperature:** 0°C to 55°C

**DUT Size:** See figure below

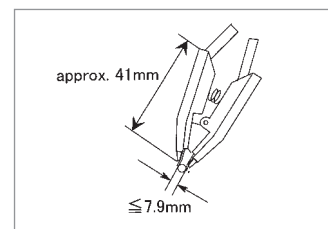

**Furnished Accessories:**

Description	P/N	Qty.
Operating and Service Manual	16089-90020	1

**Compensation and Measurement:** Open and short compensations are recommended before measurement. For open compensation, do not connect the Kelvin clips to anything. Short compensation is performed by connecting the Kelvin clips together. After performing open and short compensations, the DUT is held with the Kelvin clips.

## Up to 110 MHz (4-Terminal Pair) Other Components

### 16089C Kelvin IC Clip Leads

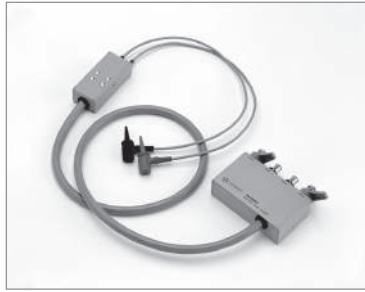

**Terminal Connector:** 4-Terminal Pair, BNC

**DUT Connection:** 4-Terminal

**Cable Length (approx.):**

1.3m (from connector to clip's tip)

**Weight (approx.):** 300 g

**Additional Error:** The additional error is negligible when compared to the instrument's accuracy.

**Description:** This test fixture makes it possible to measure odd-shaped components that cannot be measured with conventional fixtures. It is equipped with two insulated Kelvin clips.

**Applicable Instruments:** 4263B, 4268A\*, (4284A\*, 4285A, 4288A\*, 4294A, E4980A, E4981A)\*\*

\* denotes the instrument is obsolete.

\*\* applicable in a limited frequency range.

**Frequency:** 5 Hz to 100 kHz

**Maximum Voltage:**  $\pm 42$  V peak max. (AC+DC)

**Operating Temperature:** 0°C to 55°C

**DUT Size:**

See figure below

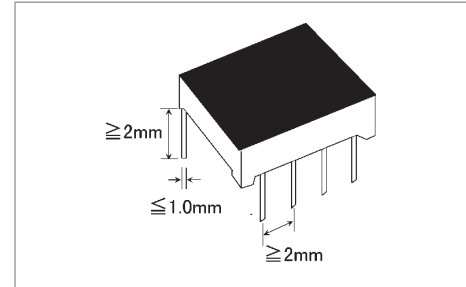

#### Furnished Accessories:

Description	P/N	Qty.
Operating and Service Manual	16089-90020	1

**Compensation and Measurement:** Open and short compensations are recommended before measurement. For open compensation, do not connect the Kelvin clips to anything. Short compensation is performed by connecting the Kelvin clips together. After performing open and short compensations, the DUT is held with the Kelvin clips.

### 16089D Kelvin Alligator Clip Leads



**Terminal Connector:** 4-Terminal Pair, BNC

**DUT Connection:** 4-Terminal

**Cable Length (approx.):**

0.94m (from connector to clip's tip)

**Weight (approx.):** 460 g

**Additional Error:** The additional error is negligible when compared to the instrument's accuracy.

**Description:** This test fixture makes it possible to measure odd-shaped components that cannot be measured with conventional fixtures. It is equipped with four alligator clips.

**Applicable Instruments:** 4263B, 4268A\*, (4284A\*, 4285A, 4288A\*, 4294A, E4980A, E4981A)\*\*

\* denotes the instrument is obsolete.

\*\* applicable in a limited frequency range.

**Frequency:** 5 Hz to 100 kHz

**Maximum Voltage:**  $\pm 42$  V peak max. (AC+DC)

**Operating Temperature:** 0°C to 55°C

**DUT Size:** diameter of DUT's leads  $\leq 5$  mm

#### Furnished Accessories:

Description	P/N	Qty.
Operating and Service Manual	16089-90020	1

**Compensation and Measurement:** Open and short compensations are recommended before measurement. For open compensation, do not connect the alligator clips to anything. Short compensation is performed by holding a shorting plate with the alligator clips. Make sure that the alligator clips with the "V" markers are next to each other. After performing open and short compensations, the DUT is held with the alligator clips. Connect the same color test clips to the same terminal of the DUT and have the clips with "V" markers be closer to the DUT.

## Up to 110 MHz (4-Terminal Pair) Port/Cable Extension

### 16048A Test Leads



**Terminal Connector:** 4-Terminal Pair, BNC

**Cable Length (approx.):**

0.94m (from connector to cable tip)

**Cable Tip:** BNC (male)

**Weight (approx.):** 315 g

**Additional Error:** For detailed information, refer to the measurement instrument's specifications.

**Description:** The test leads extend the measurement port with a 4-Terminal Pair configuration. It is provided with a BNC female connector board to allow the attachment of user-fabricated test fixtures.

**Applicable Instruments:** 4263B, 4268A\*, 4279A\*, 4284A\*, 4285A, 4288A\*, E4980A, E4981A

\* denotes the instrument is obsolete.

**Frequency:** DC to 30 MHz

**Maximum Voltage:**  $\pm 42$  V peak max. (AC+DC)

**Operating Temperature:** 0°C to 55°C

**Furnished Accessories:**

Description	P/N	Qty.
Terminal Board with BNC(f)x4	16032-60001	1
Operating Manual	16089-90001	1

**Compensation and Measurement:** Cable length compensation is recommended before measurement. Set the instrument's cable length compensation function to 1 m.

### 16048D Test Leads



**Terminal Connector:** 4-Terminal Pair, BNC

**Cable Length (approx.):**

1.89 m (from connector to cable tip)

**Cable Tip:** BNC (male)

**Weight (approx.):** 460 g

**Additional Error:** For detailed information, refer to the measurement instrument's specifications.

**Description:** The test leads extend the measurement port with a 4-Terminal Pair configuration. It is provided with a BNC female connector board to allow the attachment of user-fabricated test fixtures.

**Applicable Instruments:** 4263B, 4268A\*, 4279A\*, 4284A\*<sup>1</sup>, 4285A, 4288A\*, E4980A, E4981A

\* denotes the instrument is obsolete.

1. Requires Option 006.

**Frequency:** DC to 30 MHz

**Maximum Voltage:**  $\pm 42$  V peak max. (AC+DC)

**Operating Temperature:** 0°C to 55°C

**Furnished Accessories:**

Description	P/N	Qty.
Terminal Board with BNC(f)x4	16032-60001	1
Operating Manual	16048-90031	1

**Compensation and Measurement:** Cable length compensation is recommended before measurement. Set the instrument's cable length compensation function to 2 m.



## Up to 110 MHz (4-Terminal Pair) Port/Cable Extension

### 16048E Test Leads



**Terminal Connector:** 4-Terminal Pair, BNC

**Cable Length (approx.):** 3.8 m(from connector to cable tip)

**Cable Tip:** BNC (male)

**Weight (approx.):** 690 g

**Additional Error:** For detailed information, refer to the measurement instrument's specifications.

**Description:** The test leads extend the measurement port with a 4-Terminal Pair configuration. It is provided with a BNC female connector board to allow the attachment of user-fabricated test fixtures.

**Applicable Instruments:** 4263B, 4284A\*<sup>1</sup>, E4980A

\* denotes the instrument is obsolete.

1. Requires Option 006.

**Frequency:** DC to 2 MHz

**Maximum Voltage:**  $\pm 42$  V peak max. (AC+DC)

**Operating Temperature:** 0°C to 55°C

**Furnished Accessories:**

Description	P/N	Qty.
Terminal Board with BNC(f)x4	16032-60001	1
Operating Manual	16048-90041	1

**Compensation and Measurement:** Cable length compensation is recommended before measurement. Set the instrument's cable length compensation function to 4 m.

## Up to 110 MHz (4-Terminal Pair) Port/Cable Extension

### 16048G Test Leads

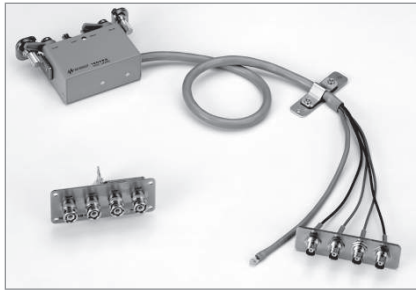

**Terminal Connector:** 4-Terminal Pair, BNC

**Cable Length (approx.):** 1 m

**Cable Tip:** BNC (female)

**Weight (approx.):** 460 g

**Additional Error:** For detailed information, refer to the operation manual or the specifications of 4294A.

**Description:** The test leads extend the measurement port with a 4-Terminal Pair configuration. It is provided with a BNC male connector board to allow the attachment of user-fabricated test fixtures.

**Applicable Instrument:** 4294A

**Frequency:** DC to 110 MHz

**Maximum Voltage:**  $\pm 42$  V peak max. (AC+DC)

**Operating Temperature:**  $-20^{\circ}\text{C}$  to  $150^{\circ}\text{C}$

**Furnished Accessories:**

Description	P/N	Qty.
Mounting Plate	NA	1
Operating and Service Manual	16048-90050	1

#### Options:

16048G-001: Add BNC Bracket\* (P/N 16048-60003)

\* Here the BNC Bracket refers to the terminal board with four BNC (m) connectors.

**Compensation and Measurement:** Adapter setup is recommended before measurement. In the adapter setup menu, select 4TP 1M. Then use the  $100\ \Omega$  resistor furnished with the 4294A to perform phase compensation and load data measurement.

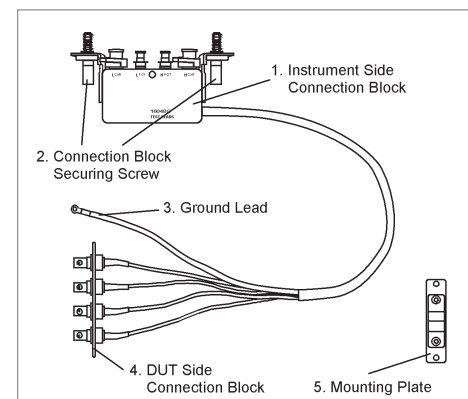

Test fixture overview

### 16048H Test Leads

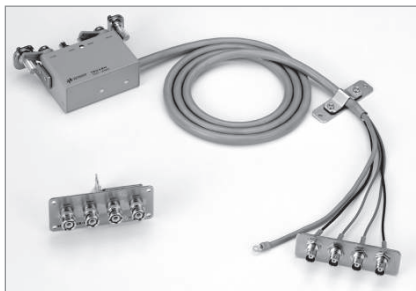

**Terminal Connector:** 4-Terminal Pair, BNC

**Cable Length (approx.):** 2 m

**Cable Tip:** BNC (female)

**Weight (approx.):** 690 g

**Additional Error:** For detailed information, refer to the operation manual or the specifications of 4294A.

**Description:** The test leads extend the measurement port with a 4-Terminal Pair configuration. It is provided with a BNC male connector board to allow the attachment of user-fabricated test fixtures.

**Applicable Instrument:** 4294A

**Frequency:** DC to 110 MHz

**Maximum Voltage:**  $\pm 42$  V peak max. (AC+DC)

**Operating Temperature:**  $-20^{\circ}\text{C}$  to  $150^{\circ}\text{C}$

**Furnished Accessories:**

Description	P/N	Qty.
Mounting Plate	NA	1
Operating and Service Manual	16048-90050	1

#### Options:

16048H-001: Add BNC Bracket\* (P/N 16048-60003)

\* Here the BNC Bracket refers to the terminal board with four BNC (m) connectors.

**Compensation and Measurement:** Adapter setup is recommended before measurement. In the adapter setup menu, select 4TP 2M. Then use the  $100\ \Omega$  resistor furnished with the 4294A to perform phase compensation and load data measurement.

# Up to 110 MHz (4-Terminal Pair) Probes

## 42941A Impedance Probe Kit



**Terminal Connector:** 4-Terminal Pair, BNC

**Cable Length (approx.):** 1.5 m

**Weight (approx.):** 2400 g

**Basic Measurement Accuracy:** ±1%

For detailed information, refer to the operation manual or the specifications of 4294A.

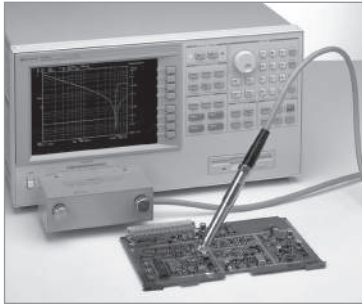

4294A with 42941A

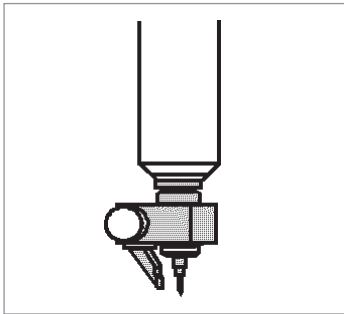

Open compensation

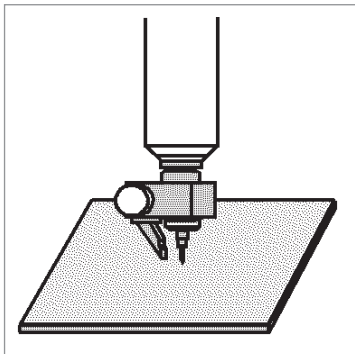

Short compensation

**Description:** This impedance probe kit is designed for use with the 4294A. It provides the capability to perform in-circuit measurements (printed circuit patterns, the input/output impedance of circuits, etc.) with better accuracy and wider impedance coverage from 40 Hz to 110 MHz. DUTs can be connected by either using the pin probe, the clip lead (alligator clip adapter) or the BNC adapter. All probe adapter can be used from 40 Hz to 110 MHz. The pin probe is best for in-circuit, board-mounted components, The clip lead is for components too large for the pin probe. The BNC adapter is used to connect circuits or networks equipped with BNC connectors.

**Applicable Instrument:** 4294A

**Frequency:** 40 Hz to 110 MHz

**Maximum Voltage:** ±42 V peak max. (AC+DC)

**Operating Temperature:** -20°C to +75°C (probe only)

**Furnished Accessories:**

Description	P/N	Qty.
Pin Probe	42941-60002	1
Adapter BNC-SMA	1250-2375	1
Spare Pin Set (3 ea.)	42941-60004	1
3.5 mm SHORT	1250-2840	1
3.5 mm LOAD	0955-1105	1
Clip lead	8121-0003	1
Ground lead	04193-61679	1
Carrying case	42941-60011	1
Operating and Service Manual	42941-90010	1

**Compensation and Measurement:** Adapter setup and compensation is required before measurement. In the Adapter setup menu, select PROBE 42941A. Use the furnished 3.5 mm short and load standards. The open condition can be created by not connecting the probe to anything. Perform phase compensation, short and load data measurements. For compensation, open and short compensation is recommended. Short compensation is performed by shorting the probe. To short the probe it is recommended to use a shorting device with gold-plated surfacing (which provides stable contact resistance).

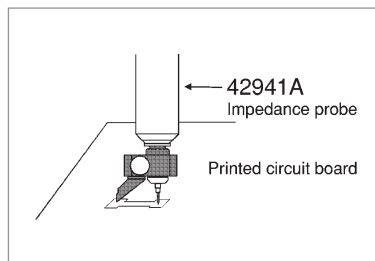

In-circuit measurement

## Up to 110 MHz (4-Terminal Pair) DC Bias Accessories

### 16065A 200Vdc External Voltage Bias Fixture



**Terminal Connector:** 4-Terminal Pair, BNC  
**DUT Connection:** 4-Terminal  
**External Bias Input connector:** High Voltage BNC(f)  
**Dimensions (approx.):** 180(W) x 120(H) x 200(D) [mm]  
**Cable Length (approx.):** 40 cm  
**Weight (approx.):** 1500 g



High Voltage BNC(f) connector for external bias input  
 BNC(f) connector for voltage monitor output

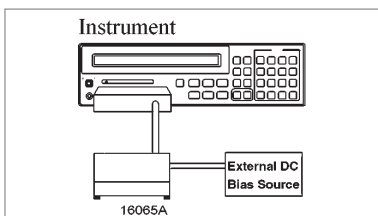

LCR meter with 16065A

### 16065C 40Vdc External Voltage Bias Adapter



**Terminal Connector:** 4-Terminal Pair, BNC  
**External Bias Input connector:** BNC(f)  
**Dimensions (approx.):** 160(W) x 50(H) x 150(D) [mm]  
**Cable Length (approx.):** 210 mm  
**Weight (approx.):** 450 g

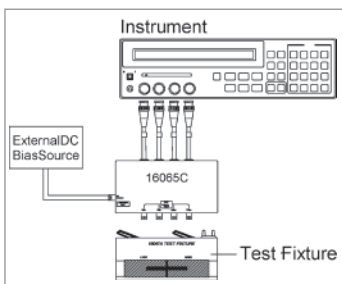

LCR meter with 16065C

**Description:** This test fixture makes it possible to measure a DUT with up to  $\pm 200$  V DC bias. The same modules of 16047A can be used to allow measurements of axial/radial lead components.

**Applicable Instruments:** 4263B, 4268A\*, 4279A\*, 4288A\*, E4981A (4284A\*, 4285A, 4294A, E4980A)\*\*

\* denotes the instrument is obsolete.

\*\* applicable in a limited frequency range.

**Frequency:** 50 Hz to 2 MHz

**Maximum DC Bias:**  $\pm 200$  V DC max. /15 V peak AC max.

Blocking Capacitor of 5.6  $\mu$ F is connected in with the Hc terminal.

**Operating Temperature:** 0°C to 55°C

**DUT Size:** See the 16047A figure with module sizes.

**Furnished Accessories:**

Description	P/N	Qty.
Module For Axial Lead	16061-70022	1
Module For Radial Lead mounting on fixture	16061-70021	1
Module For Short Radial Lead	16047-65001	1
Shorting Bar	16047-00640	1
Operating and Service Manual	16065-90011	1

**Compensation and Measurement:** Open, short and load compensations are recommended before measurement. Short compensation is performed by shorting the contacts of the test fixture with a shorting plate as described for the 16047A. Load compensation is performed by inserting a known standard device. After performing open, short and load compensations, the DUT is connected to the test fixture.

**Description:** This adapter is designed to operate specifically with the 4263B, 4268A\*, 4288A\* and the E4981A. By connecting an external DC voltage source to this adapter, a bias voltage of up to  $\pm 40$  V can be supplied to a DUT. The DUT can be inserted by connecting any direct attachment 4-Terminal Pair test fixture to the adapter.

**Applicable Instruments:** 4263B, 4268A\*, 4288A\*, E4981A

**Frequency:** 100 Hz to 1 MHz

**Maximum DC Bias:**  $\pm 42$  V peak max. (AC+DC)

Blocking Capacitor of 100  $\mu$ F is connected in series with the Hc terminal.

**Operating Temperature:** 0 °C to 55 °C

**Applicable Fixtures:** 16034E/G/H, 16044A, 16047A/D\*/E, 16048A/B\*/D/E, 16089A/B/C/D/E\*

\* denotes the instrument is obsolete.

**Furnished Accessories:**

Description	P/N	Qty.
Operating and Service Manual	16065-90020	1

**Compensation and Measurement:** Open and short compensations are recommended before measurement. Short compensation is performed by shorting the contacts of the test fixture that is in use. After performing open and short compensations, the DUT is connected to the test fixture.

# Up to 110 MHz (4-Terminal Pair) Material

## 16451B Dielectric Test Fixture

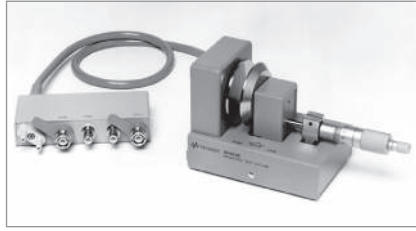

**Terminal Connector:** 4-Terminal Pair, BNC  
**Dimension (approx.):** See page 29  
**Cable Length (approx.):**  
 0.8 m (from connector to electrodes)  
**Weight (approx.):** 3700 g  
**Measurement Accuracy**

$$\epsilon'_r \text{ accuracy } \left( \frac{\Delta \epsilon'_r}{\epsilon'_r} \right)$$

$$\tan \delta < 0.1 :$$

$$A_z + 0.04 f^2 \epsilon'_{rm} \epsilon_0 \left( \frac{\pi \left( \frac{d}{2} \right)^2}{t} \right) + \frac{100 (\epsilon'_{rm} - 1)}{(\epsilon'_{rm} - \frac{t}{0.01})} [\%]$$

$\epsilon''$  Loss Tangent Accuracy ( $\Delta \tan \delta$ )  
 $\tan \delta < 0.1 : A_d + E_a + E_b$

$$E_a = 0.005 + 0.0004 f^2 \epsilon'_{rm} \epsilon_0 \left( \frac{\pi \left( \frac{d}{2} \right)^2}{t} \right)$$

$$E_b = \frac{\tan \delta}{100} \frac{\Delta \epsilon'_{rm}}{\epsilon'_{rm}}$$

### (supplemental performance characteristics):

f: measured frequency [Hz]  $f \leq 30\text{MHz}$

$\epsilon'_{rm}$ : measured permittivity

$\tan \delta$ : measured dissipation factor

$\epsilon_0$ : permittivity of air  $8.854 \times 10^{-12} [\text{F/m}]$

d: diameter of electrode {A,B}

t: thickness of material [mm]

A<sub>z</sub>: Impedance measurement error of instrument

A<sub>d</sub>: D measurement error of instrument

The material is assumed to be ideally flat.

The above equation is applicable for electrodes A and B when using the contacting electrode method.

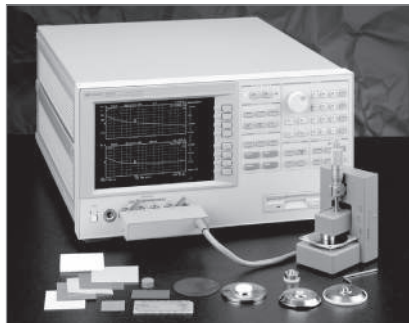

4294A with 16451B

**Description:** The 16451B is used to evaluate the dielectric constant of solid dielectric materials accurately, and complies with ASTM D150. The 16451B employs the parallel plate method, which sandwiches the material between two electrodes to form a capacitor. LCR meter or an Impedance Analyzer is then used to measure the capacitance created from the fixture. A measurement block diagram of the parallel plate method is shown below:

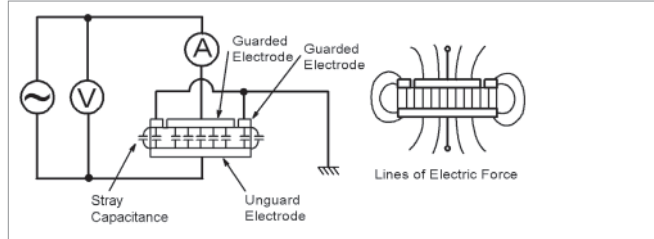

Parallel plate method

Notice the stray capacitance, which is formed on the test material as shown in the figure above. The guard electrode helps to eliminate the stray capacitance at the edge of the electrode.

## Basic Measurement Accuracy (including the 4294A):

Typical Permittivity ( $\epsilon'$ ) Measurement Accuracy:

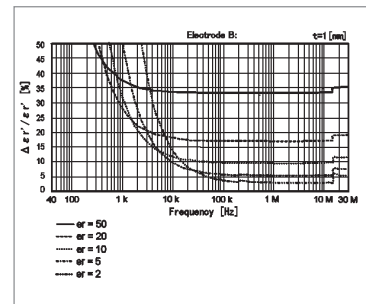
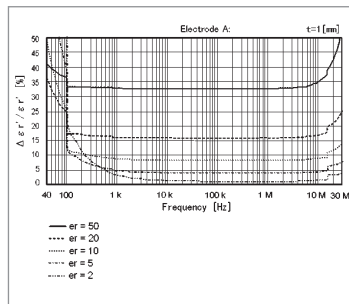

Typical Loss Tangent ( $\tan \delta$ ) Measurement Accuracy:

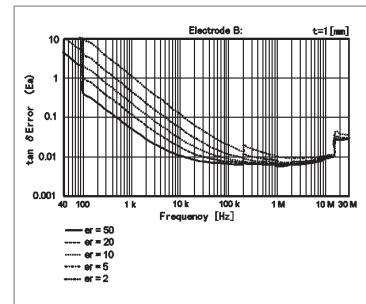
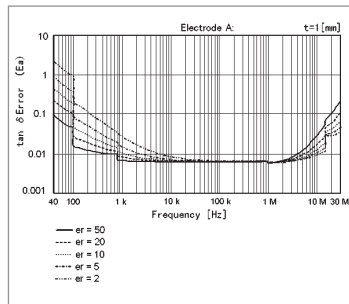

4294A Measurement Settings:

1. Osc level : 500 mV
2. BW: 5
3. Adapter setup : 1 m
4. Compensation : Open, short and load

# Up to 110 MHz (4-Terminal Pair) Material

**Applicable Instruments:** 4263B, 4268A\*, 4279A\*, 4284A\*, 4285A, 4288A\*, E4980A, E4981A, (4294A)\*\*

\* denotes the instrument is obsolete.

\*\* applicable in a limited frequency range.

**Frequency:** DC to 30 MHz

**Maximum Voltage:**  $\pm 42$  V peak max. (AC+DC)

**Operating Temperature:** 0°C to 55°C

## Material Size:

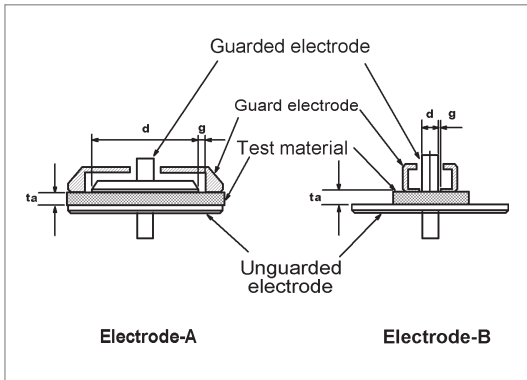

Electrodes for contacting electrode method (Rigid Metal Electrode)

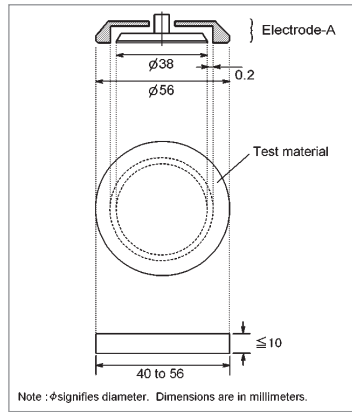

Material size for electrode-A

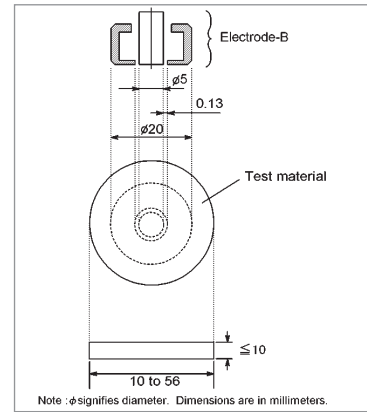

Material size for electrode-B

Equipped with Electrodes A and B for flat and smooth materials.

Electrode Type	Diameter of MUT	Thickness of MUT	Diameter of Electrode	Max. Frequency
A	40 mm ~ 56 mm	$t \leq 10$ mm	38 mm	30 MHz
B	10 mm ~ 56 mm	$t \leq 10$ mm	5 mm	30 MHz

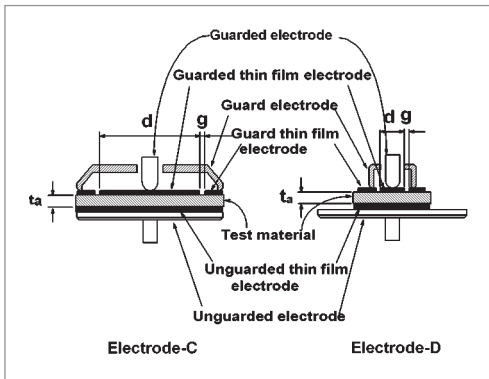

Electrodes for contacting electrode method (Thin Film Electrode)

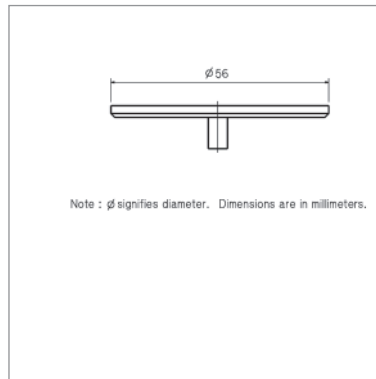

Material size for electrode-C

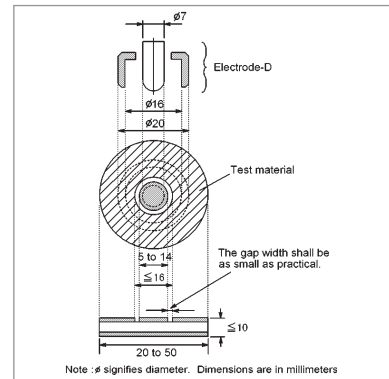

Material size for electrode-D

Equipped with Electrodes C and D for rough or extremely thin materials.

Electrode Type	Diameter of MUT	Thickness of MUT	Diameter of Electrode	Max. Frequency
C	56 mm	$t \leq 10$ mm	5 ~ 50 mm	30 MHz
D	20 mm ~ 56 mm	$t \leq 10$ mm	5 ~ 14 mm	30 MHz

\* diameter of applied thin film electrode

# Up to 110 MHz (4-Terminal Pair) Material

## Furnished Accessories:

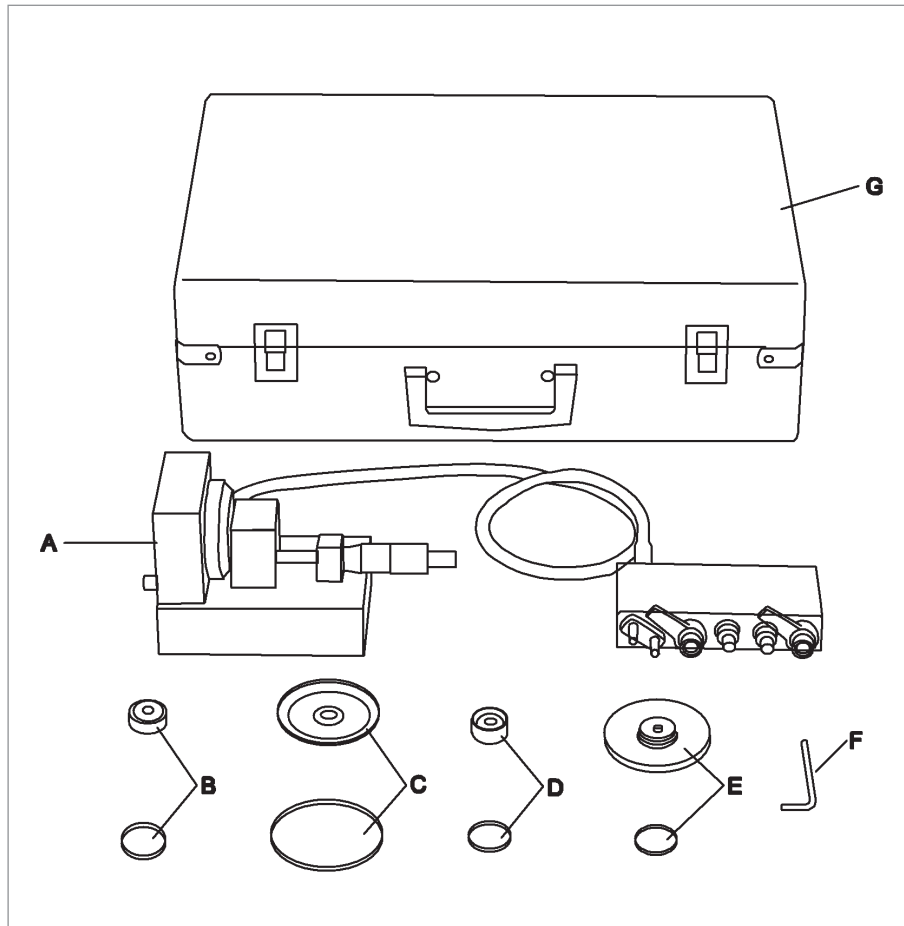

Description	P/N	Qty.	
Test Fixture including Electrode-A, unguarded electrode and cover	N/A	1	A
Electrode-B and cover	16451-60013	1	B
Electrode-C and cover	16451-60012	1	C
Electrode-D and cover	16451-60014	1	D
Attachment for error compensation and cover	16451-60021	1	E
Hex key (for replacing electrodes)	5188-4452	1	F
Carrying Case	16451-60001	1	G

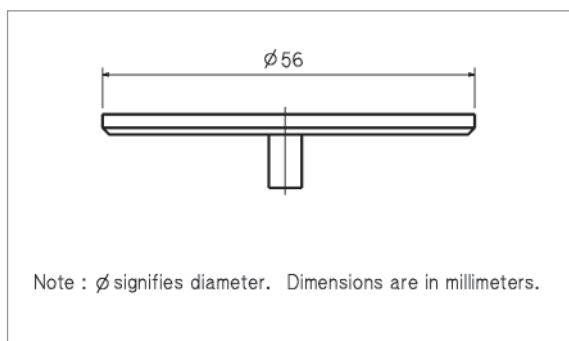

Dimensions of unguarded electrode

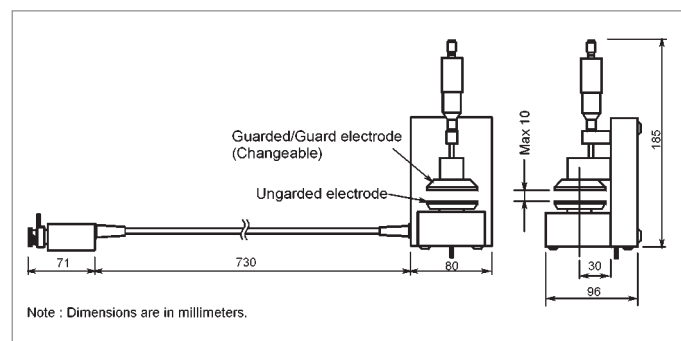

Dimensions of fixture assembly

## Up to 110 MHz (4-Terminal Pair) Material

**Compensation and Measurement:** There are three measurement methods for the 16451B. They are the Contacting Electrode Method (used with 16451B's rigid metal electrode, without any electrodes on the material under test), the Contacting Electrode Method (used with thin film electrodes made on the material under test), and the Non-Contacting Electrode (Air Gap method). Select the suitable measurement method and the suitable electrode for the material under test according to the following table.

**Summary of Measurement Method**

Measurement Method	Contacting Electrode Method (used with Rigid metal electrode)	Contacting Electrode Method (used with thin film electrode)	Non-contacting Electrode Method
Accuracy	Low		High
Operation	Simple		Complex
Applicable Materials	Thick, solid and smooth materials	Materials on which thin film can be applied without changing its characteristics	Thick, and soft materials Rough materials also

Open and short compensations are recommended in combination with the cable length compensation before measurement. When measuring above 5 MHz with the 4285A or the 4294A\*, load compensation is also recommended. First, set the instrument's cable length compensation function to 1 m. Then, open and short compensation is performed by using the furnished electrode attachment. Load compensation is performed, by preparing a working standard. After performing open, short and load compensations, the MUT is sandwiched by the parallel electrodes and the capacitance is measured. Relative permittivity is calculated from the measured capacitance in the following manner:

$$\epsilon_r = \frac{t_a \times C_p}{\pi \times \left(\frac{d}{2}\right)^2 \times \epsilon_o}$$

- $\epsilon_r$  : Relative permittivity
- $C_p$  : Capacitance (measurement data)
- $\epsilon_o$  :  $8.854 \times 10^{-12}$  [F/m]
- $t_a$  : Average thickness of test material
- $d$  : Diameter of guarded electrode

\* For more information on load compensation with the 4294A, refer to section 6 calibration of the 4294A operation manual (Fixture Compensation when the 16451B is used) and section 13 of the 4294A programming manual (Measuring Dielectric Materials).



# Up to 110 MHz (4-Terminal Pair) Material

## 16452A Liquid Dielectric Test Fixture

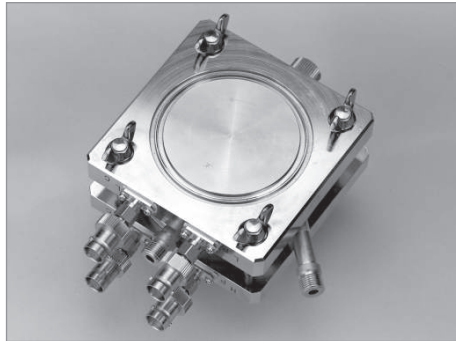

**Terminal Connector:** 4-Terminal Pair, SMA  
**Dimensions (approx.):** 85(H) x 85(W) x 37(D) [mm]  
**Weight (approx.):** 1400 g  
**Measurement Accuracy:** A + B + C [%]

Error A [%]

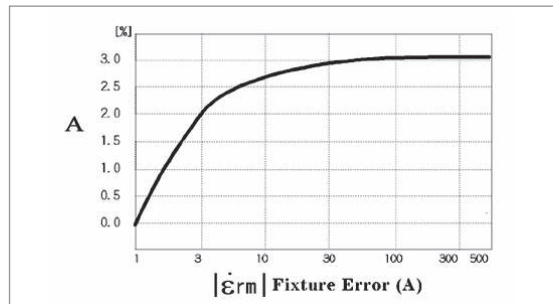

Error B [%]

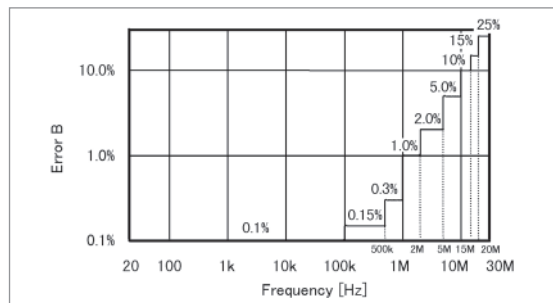

Error C [%] = Measurement Error of Instrument



LCR meter with 16452A

**Description:** This test fixture provides accurate dielectric constant and impedance measurements of liquid materials. The 16452A employs the parallel plate method, which sandwiches the liquid material between two electrodes to form a capacitor. A LCR meter or an impedance analyzer is then used to measure the capacitance created from the fixture.

**Applicable Instruments:** 4263B, 4284A\*, 4285A, E4980A, (4294A)\*\*

\* denotes the instrument is obsolete.

\*\* applicable in a limited frequency range.

**Frequency:** 20 Hz to 30 MHz

**Operating Temperature:** -20°C to 125°C

**Maximum Voltage:** 30 Vrms

**Material Capacity:** Required sample liquid capacity depends on the gap of the electrodes.

Gap of electrodes	0.3 mm	0.5 mm	1 mm	2 mm
Air capacitance	34.9 pF ±25%	21.2 pF ±15%	10.9 pF ±10%	5.5 pF ±10%
Sample liquid capacity	3.4 ml	3.8 ml	4.8 ml	6.8 ml
Applicable frequency	20 Hz - 30 MHz			

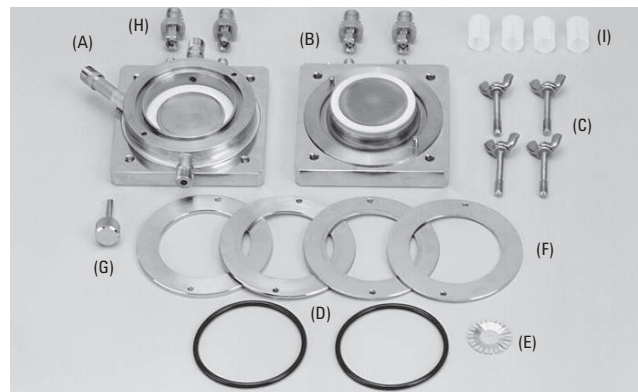

### Furnished Accessories:

Description	P/N	Qty.
Shorting Plate	16092-08010	1 E
O-ring for Liquid Outlet	0905-1277	1 D
Spacer (1.3 mm thickness)	16452-00601	1 F
Spacer (1.5 mm thickness)	16452-00602	1 F
Spacer (2.0 mm thickness)	16452-00603	1 F
Spacer (3.0 mm thickness)	16452-00604	1 F
Lid of Liquid Outlet 16452-24002	1	G
SMA-BNC Adapter 1250-1200	4	H
Waterproof Cap for BNC Connector	1252-5821	4 I
Carrying Case	16452-60111	1 -
Operation and Service Manual	16452-90020	1 -
Angle Iron of Stand Body for Fixture Stand	16452-01201	2 -
Screw of Stand Body or Fixture Stand	0515-0914	4 -
Screw for Fixture Stand	0515-0914	4 -
Stand Foot	16452-00611	1 -
Electrode (High and Low)	NA	2 A.B

Requires the following interface cables to connect to a measurement instrument. Select accordingly to the required temperature conditions.

Temperature	Model# or P/N	Cable length (approx.)
0°C to 55°C	16048A	0.94 m
-20°C to 150°C	16048G* for 4294A only	1 m
-20°C to 150°C	16048H* for 4294A only	2 m

\* Four BNC(m) to BNC(m) adapters (P/N 1250-0216) are needed to connect the 16048G/H and 16452A.

# Up to 110 MHz (4-Terminal Pair) Material

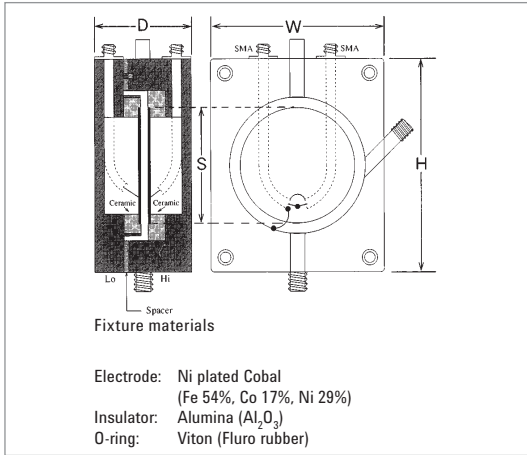

Test fixture overview

**Compensation and Measurement:** Short compensation is recommended in combination with the cable length compensation before measurement. First, set the instrument's cable length compensation function to 1 m. Then, short compensation is performed by using the furnished shorting plate. Open compensation is not performed, but its values are used in the dielectric constant equation as shown below:

$$\epsilon_r = a \left( \frac{C_p}{C_o} - j \frac{1}{\omega C_o R_p} \right)$$

- $a$ : Correction coefficient
- $\epsilon_r$ : Relative dielectric constant
- $C_p$ : Liquid capacitance (measurement data)
- $C_o$ : Air capacitance (measurement data) or open compensation data
- $R_p$ : Equivalent parallel resistance (measurement data)
- $\omega$ : Angular frequency ( $\omega=2\pi f$ )

The following figures below show how compensation and measurement is performed.

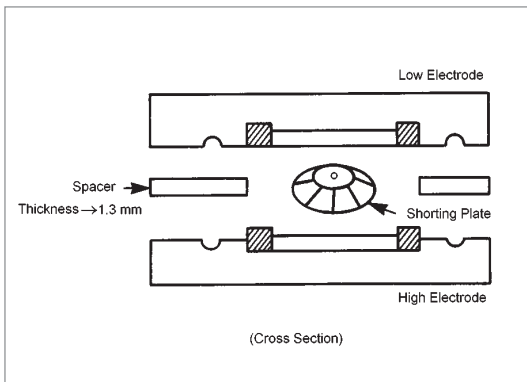

Short compensation

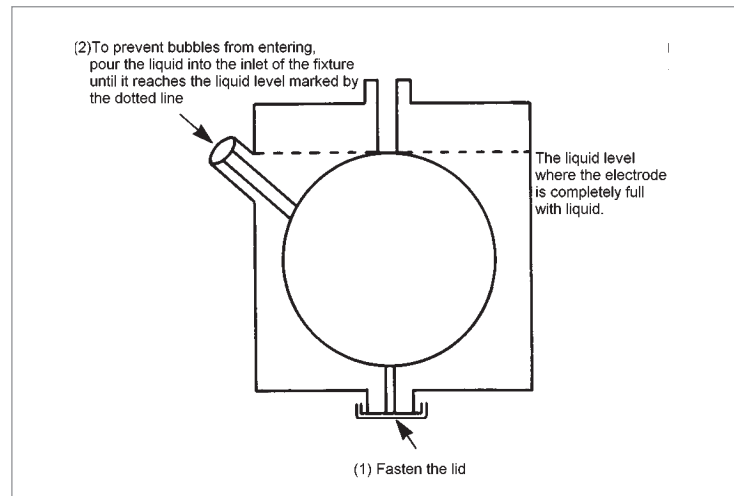

Pouring the liquid into the fixture

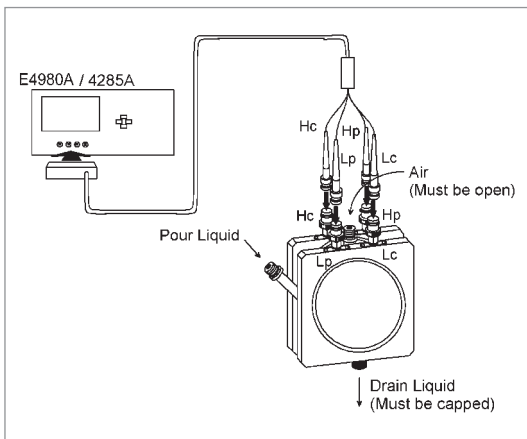

Method of connection

Note: the 16452A is not capable of measuring salt or ionic solutions or other liquids with bulk conductivity due to the electrode polarization phenomenon.

Keysight is not responsible for any damage (e.g., corrosion, smear) to the 16452A caused by the reaction between the liquid under test and the 16452A.

# Up to 3 GHz (7 mm)

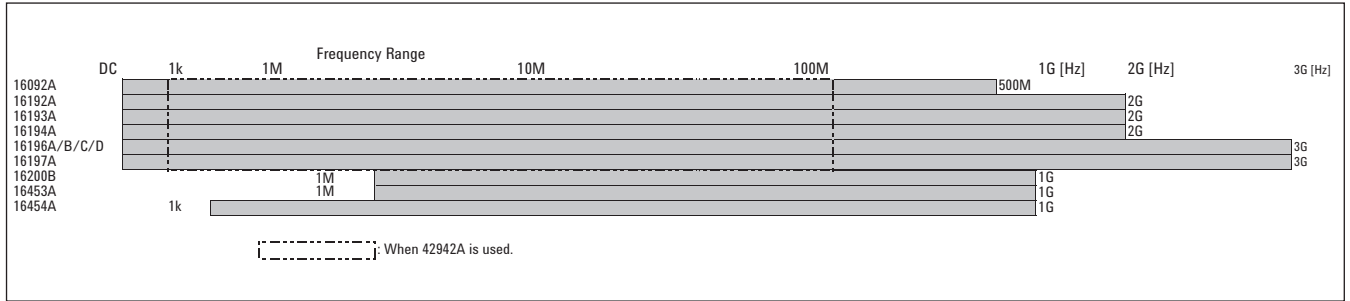

## Applicable Instrument

Frequency Range Up to 110 MHz  
(Terminal Configuration: 4-Terminal Pair)

Measurement Instruments 4263B, 4268A, 4279A, 4284A, 4285A, 4288A, 4294A, E4980A, E4981A

Up to 3 GHz  
(Terminal Configuration: 7 mm)

4291B, 4294A + 42942A, E5061B-3L5 w/Opt.005 + 16201A, 4287A, E4982A, E4991A  
Any 4TP instruments (excluding 4294A) + 16085B

Frequency DC (High Resistance Measurement)

Measurement Instruments 4339B, 4349B

## Up to 3 GHz (7 mm) Lead Components

### 16092A Spring Clip Fixture

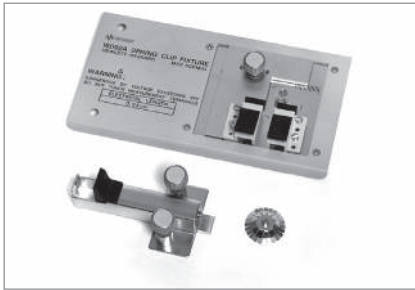

**Terminal Connector:** 7 mm

**DUT Connection:** 2-Terminal

**Electrical Length:** 3.4 mm

**Dimensions (approx.):** 150(W) x 70(H) x 80(D) [mm]

**Weight (approx.):** 180 g

**Additional Error:** See figure below

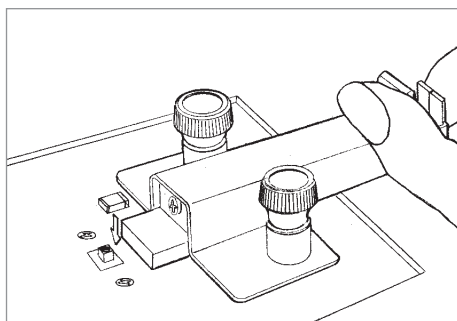
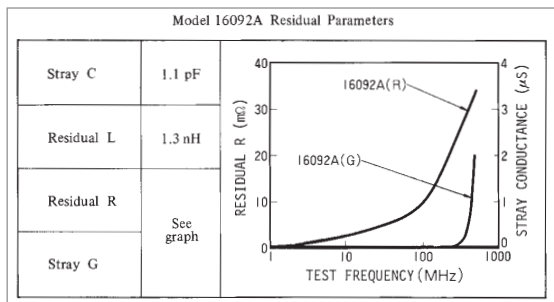

Inserting the SMD

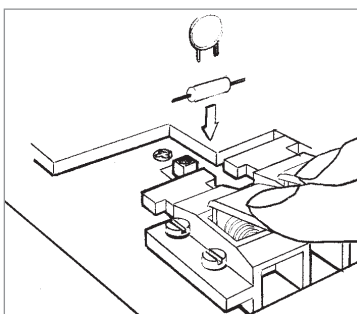

Inserting the leaded component

**Description:** This test fixture is designed for impedance evaluation of both lead and SMD. It is furnished with two modules that can be readily screwed onto the plate to measure either lead or SMD.

**Applicable Instrument:** 4294A + 42942A, (4291B\*, 4287A\*, E4982A, E5051B-3L5 with Opt. E5061B-005 + 16201A, E4991A)\*\*

When used with 16085B\*: 4263B, 4268A\*, 4279A\*, 4284A\*, 4285A, 4288A\*, E4980A, E4981A

\* denotes the instrument is obsolete.

\*\* applicable in a limited frequency range.

**Frequency:** DC to 500 MHz

**Maximum Voltage:**  $\pm 42$  V peak max. (AC+DC)

**Operating Temperature:** 0°C to 55°C

**DUT Size:** See figure below

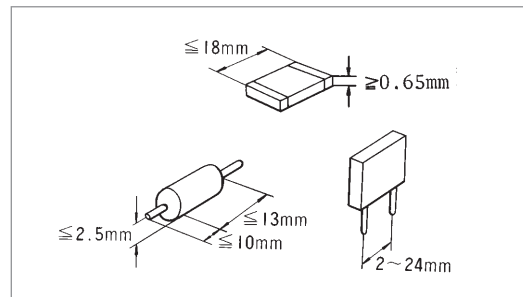

#### Furnished Accessories:

Description	P/N	Qty.
Shorting Plate	16092-08010	1
Operating Note	16092-90010	1

**Compensation and Measurement:** Open and short compensations are recommended in combination with the electrical length compensation before measurement. The fixture's electrical length must be entered into the electrical length compensation function of the measurement instrument first. When using the SMD module, open compensation is performed by separating the high and the low electrodes from each other. The separation should be equivalent in size to the DUT's width. Short compensation is performed by using the furnished shorting plate. When using the lead component module, open compensation is performed by not having the module-electrodes be connected to anything. Short compensation is performed by using the furnished shorting plate. After performing open and short compensations in combination with the electrical length compensation, the DUT is inserted into the test fixture.

# Up to 3 GHz (7 mm) SMD

## 16192A Parallel Electrode SMD Test Fixture

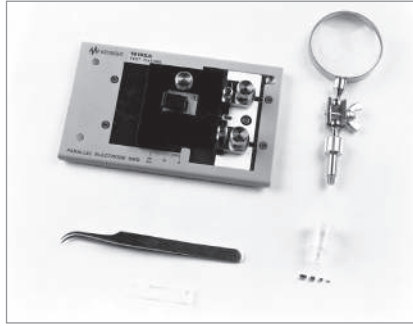

**Terminal Connector:** 7 mm

**DUT Connection:** 2-Terminal

**Electrical Length:** 11 mm

**Dimensions (approx.):** 150(W) x 70(H) x 90(D) [mm]

**Weight (approx.):** 400 g

**Additional Error:**

Type of Error	Impedance
Proportional Error	$1.5 \times f^2$ [%]
Open Repeatability	$2 + 30 \times f$ [ $\mu$ S]
Short Repeatability	$30 + 250 \times f$ [m $\Omega$ ]

f: [GHz]

**Description:** This test fixture is designed for impedance evaluations of parallel electrode SMD. The minimum SMD size that this fixture is adapted to evaluate is 1 (L) [mm].

**Applicable Instrument:** 4291B\*, 4294A + 42942A, (4287A\*, E4982A, E5061B-3L5 with Opt. E50616B-005 + 16201A, E4991A)\*\*

When used with 16085B\*: 4263B, 4268A\*, 4279A\*, 4284A\*, 4285A, 4288A\*, E4980A, E4981A

\* denotes the instrument is obsolete.

\*\* applicable in a limited frequency range.

**Frequency:** DC to 2 GHz

**Maximum Voltage:**  $\pm 42$  V peak max. (AC+DC)

**Operating Temperature:** -55°C to +85°C

**DUT size:** 1 mm to 20 mm (length)

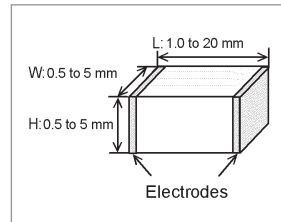

### Furnished Accessories:

Description	P/N	Qty.	Option
Operation and Service Manual	16192-90040	1	Standard
<b>General Sized</b>			
Shorting Device (1 x 1 x 2.4 (mm))	16191-29001	1	16192A-701
Shorting Device (1.6 x 2.4 x 2 (mm))	16191-29002	1	16192A-701
Shorting Device (2.4 x 2.4 x 3.2 (mm))	16191-29003	1	16192A-701
Shorting Device (2.4 x 2.4 x 4.5 (mm))	16191-29004	1	16192A-701
<b>EIA/EIAJ Industrial</b>			
<b>Standard Sized</b>			
Shorting Device (1 x 0.5 x 0.5 (mm))	16191-29005	1	16192A-010
Shorting Device (1.6 x 0.8 x 0.8 (mm))	16191-29006	1	16192A-010
Shorting Device (2.0 x 1.2 x 0.8 (mm))	16191-29007	1	16192A-010
Shorting Device (3.2 x 1.6 x 0.8 (mm))	16191-29008	1	16192A-010
Case for Shorting Devices	1540-0692	1	16192A-010/701
Magnifying Lens	16193-60002	1	16192A-710
Tweezers	8710-2081	1	16192A-710

# Up to 3 GHz (7 mm) SMD

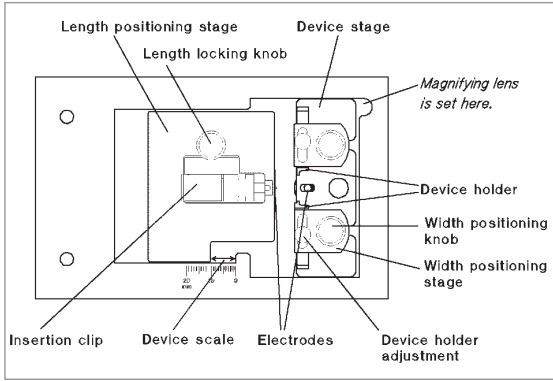

Test fixture overview

**Options:**

16192A-010: Add EIA/EIAJ industrial standard sized shorting bar set

16192A-701: Add general sized shorting bar set

16192A-710: Add the magnifying lens and tweezers

**Compensation and Measurement:** Open and short compensations are recommended in combination with the electrical length compensation before measurement. The fixture's electrical length must be entered into the electrical length compensation function of the measurement instrument first. Then open compensation is performed by separating the high and the low electrodes from each other. The separation should be equivalent in size to the DUT's width. Short compensation is performed by using option 16192A-010/701 shorting bar set. After performing open and short compensations in combination with the electrical length compensation, the DUT is inserted into the test fixture. The following figures show how compensation and measurement is performed.

<p>a. Place the shorting device/DUT so that it contacts the electrode.</p> <p>b. Adjust the two knobs and the two device holders to hold the shorting device/DUT.</p> <p>c. Tighten knob while pushing the lever.</p> <p>d. Release the lever to hold the shorting device/DUT. Perform short compensation or measure the DUT.</p> <p>e. Set the DUT on the test fixture just as you set the shorting device in the SHORT compensation.</p> <p>f. Push the black lever and remove the DUT. Perform open compensation.</p>	
<p>For more details, please refer to 16192A operation manual.</p>	

Open/Short compensation

# Up to 3 GHz (7 mm) SMD

## 16194A High Temperature Component Test Fixture

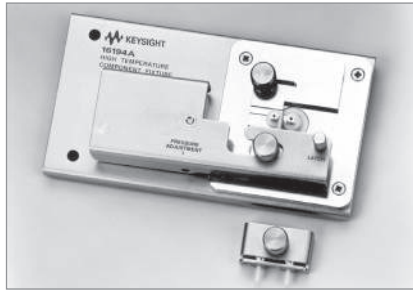

**Terminal Connector:** 7 mm  
**DUT Connection:** 2-Terminal  
**Electrical Length:** 50 mm  
**Dimensions (approx.):** 150(W) x 40(H) x 80(D) [mm]  
**Weight (approx.):** 350 g  
**Additional Error:**  
**SMD:**

Type of Error	Impedance
Proportional Error	$20 \times f^2$ [%]
Open Repeatability	$80 + 250 \times f$ [ $\mu$ S]
Short Repeatability	$0.2 + 2.5 \times f$ [ $\Omega$ ]

**Leaded device:**

Type of Error	Impedance
Proportional Error	$20 \times f^2$ [%]
Open Repeatability	$80 + 500 \times f$ [ $\mu$ S]
Short Repeatability	$0.4 + 12.5 \times f$ [ $\Omega$ ]

f: [GHz]

**Description:** This test fixture is designed for measuring both axial/radial leaded devices and SMD within the temperature range from -55 to +200 °C (when used with the E4991A-007 Temperature Characteristic Test Kit, -55 to +150 °C).

**Applicable Instrument:** 4294A + 42942A, (4287A\*, E4982A, E5061B-3L5 with Opt. E5061B-005 + 16201A, E4991A)\*\*

When used with 16085B\*: 4263B, 4268A\*, 4279A\*, 4284A\*, 4285A, 4288A\*, E4980A, E4981A

\* denotes the instrument is obsolete.

\*\* applicable in a limited frequency range.

**Frequency:**

DC to 500 MHz (with open and short compensation)

DC to 2 GHz (with open and short and load compensation)

**Maximum Voltage:**  $\pm 42$  V peak max. (AC+DC)

**Operating Temperature:** -55°C to +200°C

**DUT size:** See figure below.

**Furnished Accessories:**

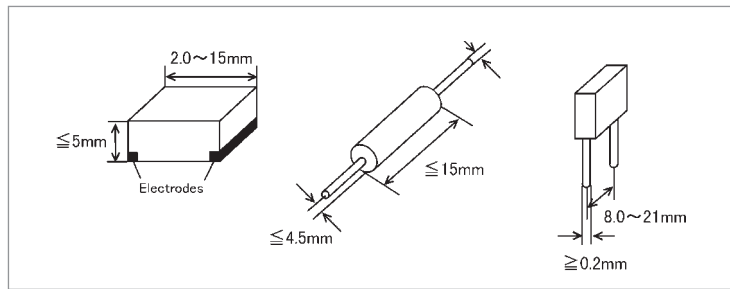

Description	P/N	Qty.	Option
Wrench	8710-1181	1	Standard
Tweezers	8710-2081	1	Standard
50 $\Omega$ SMD Resistor	0699-2829	10	Standard
Operation and Service Manual	16194-90030	1	Standard

**General Sized**

Shorting Device (1 x 1 x 2.4 (mm))	16191-29001	1	16192A-701
Shorting Device (1.6 x 2.4 x 2 (mm))	16191-29002	1	16192A-701
Shorting Device (2.4 x 2.4 x 3.2 (mm))	16191-29003	1	16192A-701
Shorting Device (2.4 x 2.4 x 4.5 (mm))	16191-29004	1	16192A-701

**EIA/EIAJ Industrial**

<b>Standard Sized</b>	16191-29005	1	16192A-010
Shorting Device (1 x 0.5 x 0.5 (mm))	16191-29006	1	16192A-010
Shorting Device (1.6 x 0.8 x 0.8 (mm))	16191-29007	1	16192A-010
Shorting Device (2.0 x 1.2 x 0.8 (mm))	16191-29008	1	16192A-010
Shorting Device (3.2 x 1.6 x 0.8 (mm))			
Case for Shorting Devices	1540-0692	1	16192A-010/701

**Options:**

16194A-010: Add EIA/EIAJ industrial standard sized shorting bar set

16194A-701: Add general sized shorting bar set

**Compensation and Measurement:** Before beginning the measurement, the appropriate device holder (for a SMD or lead component) must be prepared with the test fixture. The following figure shows how the device holder is exchanged to match the device type.

The next step is to perform open and short compensations in combination with the electrical length compensation. When measuring

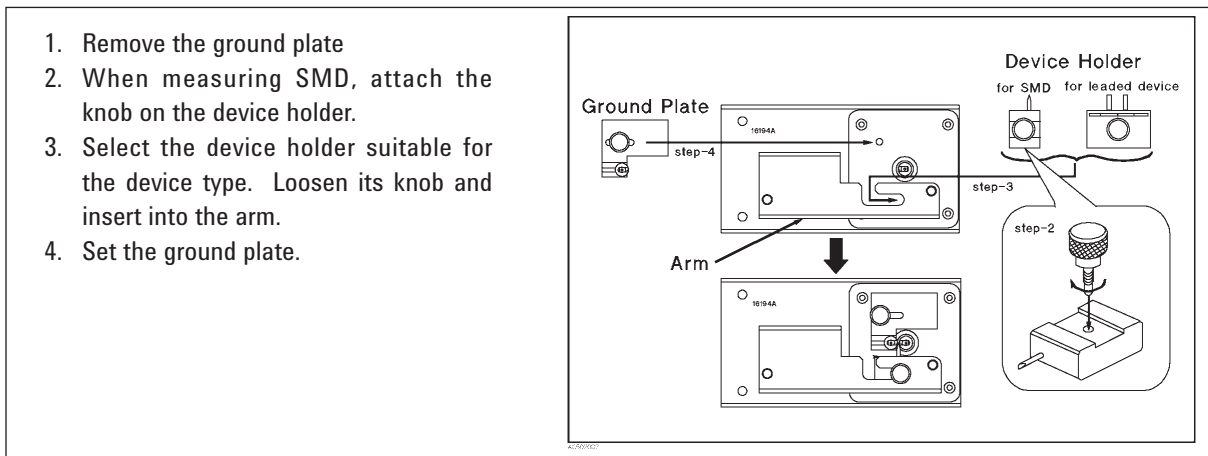

Exchanging the device holder

above 500 MHz, load compensation is also recommended. The fixture's electrical length must be entered into the electrical length compensation function of the measurement instrument first. Then open compensation is performed by separating the high and the low electrodes from each other. The separation should be equivalent in size to the DUT's width. Short compensation is performed by using the option 16194A-010/701 shorting bar set. Load compensation is performed by using the furnished 50 Ω SMD chip resistor. After performing open, short, and load compensations in combination with the electrical length compensation, the DUT is inserted into the test fixture. The following figures show how measurement is performed.

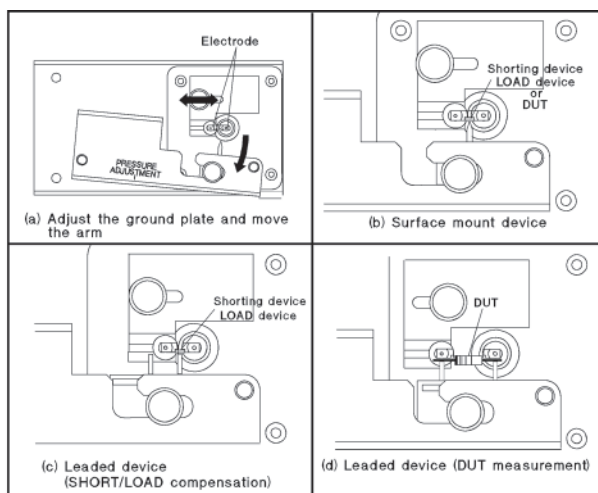

Placing the device



# Up to 3 GHz (7 mm) SMD

## 16196A Parallel Electrode SMD Test Fixture

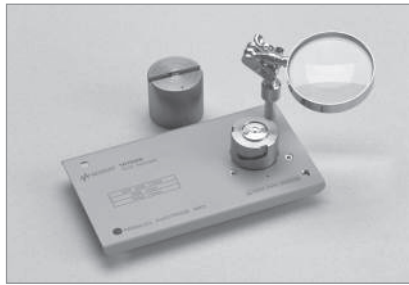

**Terminal Connector:** 7 mm  
**DUT Connection:** 2-Terminal  
**Electrical Length:** 26.2 mm  
**Dimensions (approx.):** 140(W) x 48(H) x 78(D) [mm]  
**Weight (approx.):** 250 g  
**Additional Error:**

Type of Error	Impedance
Proportional Error	$1.0 \times f^2$ [%]
Open Repeatability	$5 + 40 \times f$ [ $\mu$ S]
Short Repeatability	$30 + 125 \times f$ [m $\Omega$ ]

f: frequency [GHz]



E4982A with 16196A

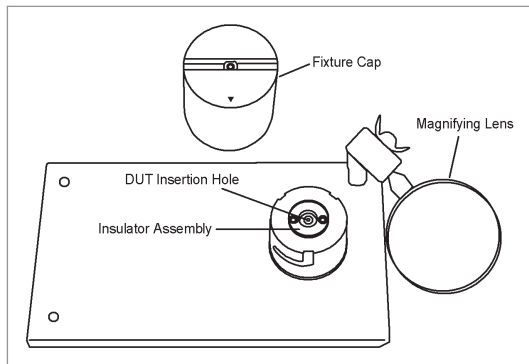

Fixture overview

**Description:** This test fixture is designed for impedance evaluations of parallel electrode SMDs. It achieves stable frequency characteristics up to 3 GHz and provides highly repeatable measurements. The applicable SMD size code is 0603 (inch)/1608 (mm).

**Applicable Instrument:** 4287A\*, E4982A, 4294A + 42942A, E5061B-3L5 with Opt. E5061B-005 + 16201A, E4991A

When used with 16085B\*: 4263B, 4268A\*, 4279A\*, 4284A\*, 4285A, 4288A\*, E4980A, E4981A

\* denotes the instrument is obsolete.

**Frequency:** DC to 3 GHz

**Maximum Voltage:**  $\pm 42$  V peak max. (AC +DC)

**Operating Temperature:** -55°C to +85°C

**DUT size:** The applicable SMD size is 0603 (inch)/1608 (mm). For details, see the figure below.

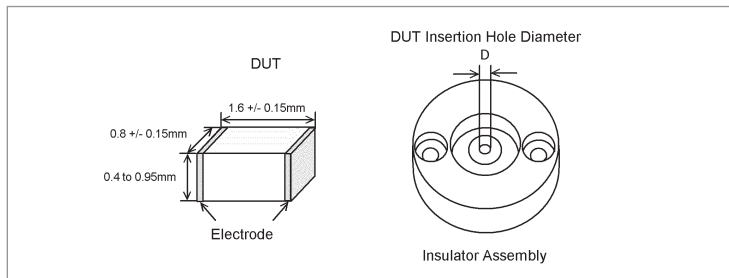

The 16196A is furnished with three different insulator assemblies, since any gaps between the DUT and the cylindrical insulator will result in improper positioning and subsequent measurement errors. Select an insulator assembly that reduces the gap the most. See the table below for dimensions of the insulator assemblies.

	Hole Diameter of Insulator assembly (mm)	SMD case size examples Length, Width, Height (mm)
16196A	$\Phi$ 1.34	1.6 x 0.8 x 0.8
	$\Phi$ 1.14	1.6 x 0.8 x 0.6
	$\Phi$ 1.08	1.6 x 0.8 x 0.5

### Furnished Accessories:

Description	P/N	Qty.
Operation and Service Manual	16196-90040	1
Insulator Assembly $\Phi$ 1.34 mm	16196-60112	1
Insulator Assembly $\Phi$ 1.14 mm	16196-60113	1
Insulator Assembly $\Phi$ 1.08 mm	16196-60114	1
Open Plate	16196-29002	1
Short Plate	16196-29026	1
Push Ring	16196-24004	1
Magnifying Lens <sup>1</sup>	16193-60002	1
Tweezers	8710-2081	1
Wrench	8710-0909	1
Cleaning Rod	5182-7586	1
Carrying Case	16196-60150	1

1: Opt. 16196A-710 only

**Options:**

16196A-710 : Add the magnifying lens and tweezers

To maintain adequate measurement performance, keep the electrodes and the short plate in good condition. Contaminants and abrasion on these parts considerably affect measurement results, especially for low value measurements. Periodic fixture cleaning and part replacement is recommended to avoid deterioration of measurement performance. The 16196x fixtures are designed with simplicity in mind, so that an operator can easily replace parts. Spare parts, which are likely to be abraded, are supplied with the 16196U Maintenance Kit.

**16196U Maintenance Kit**

Opt. 16196U-010: Upper electrode, 5 piece set (common to 16196A/B/C models)

Opt. 16196U-100: Short plate for 0603 (inch)/1608 (mm) size, 5 piece set (for 16196A)

Opt. 16196U-110: Lower electrode, 5 piece set (for 16196A)

**Compensation and Measurement:** First of all, install the appropriate insulator assembly into the fixture. Then, perform compensation. Open and short compensations are recommended in combination with the electrical length compensation before measurement. The fixture's electrical length must be entered into the electrical length compensation function of the measurement instrument first. Next, open compensation is performed by placing the furnished open plate on top of the insulator assembly. Short compensation is performed by placing the furnished shorting plate on top of the insulator assembly. After performing open and short compensations in combination with the electrical length compensation, the DUT is inserted into the test fixture. Once the measurement of the DUT is complete, remove the DUT from the fixture, by using the furnished push ring. The following figures show how compensation and measurement is performed.

Compensation and Measurement

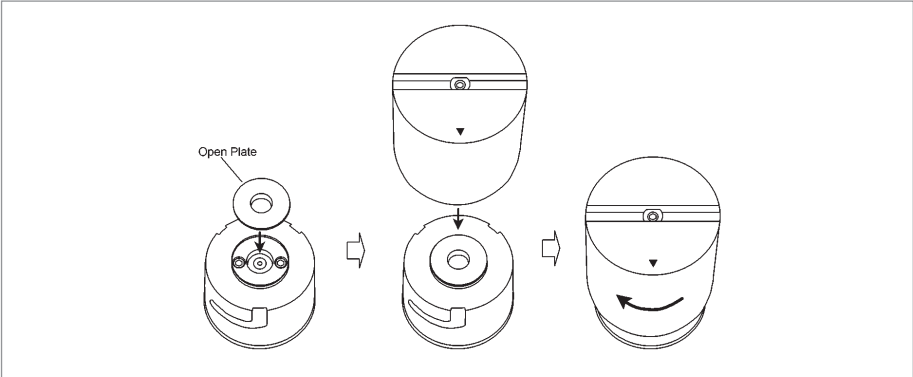

Open Compensation

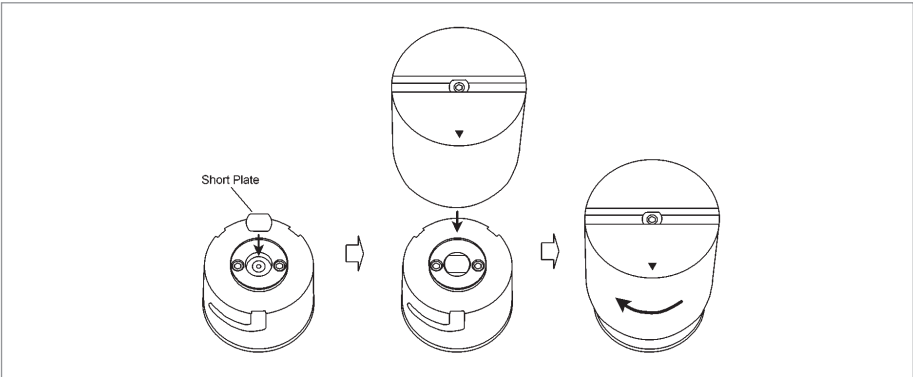

Short Compensation

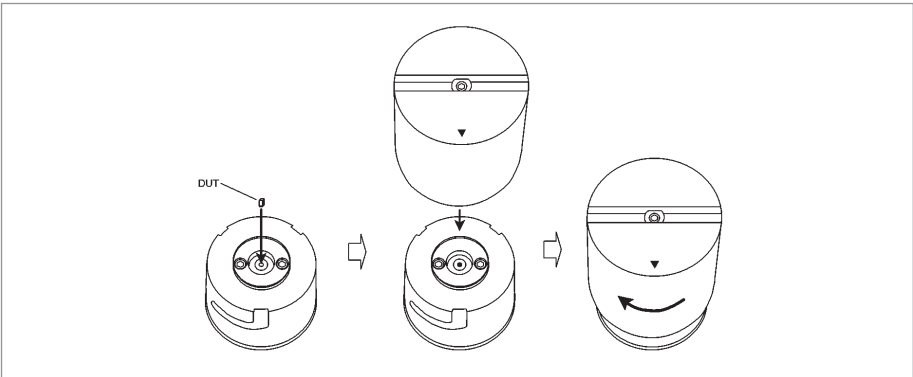

DUT Measurement

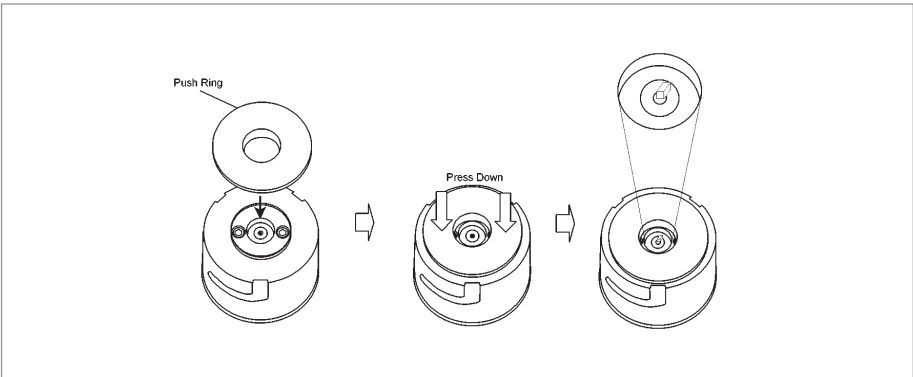

Removing a DUT

# Up to 3 GHz (7 mm) SMD

## 16196B Parallel Electrode SMD Test Fixture

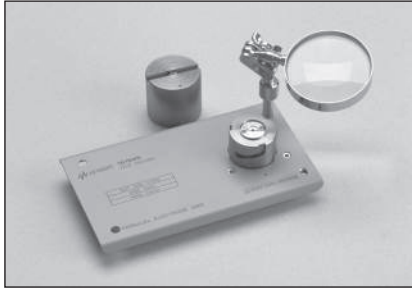

**Terminal Connector:** 7 mm  
**DUT Connection:** 2-Terminal  
**Electrical Length:** 26.9 mm  
**Dimensions (approx.):** 140(W) x 48(H) x 78(D) [mm]  
**Weight (approx.):** 250 g  
**Additional Error:**

Type of Error	Impedance
Proportional Error	$1.0 \times f^2$ [%]
Open Repeatability	$5 + 40 \times f$ [ $\mu S$ ]
Short Repeatability	$30 + 125 \times f$ [m $\Omega$ ]

f: frequency [GHz]

**Description:** This test fixture is designed for impedance evaluations of parallel electrode SMDs. It achieves stable frequency characteristics up to 3 GHz and provides highly repeatable measurements. The applicable SMD size code is 0402 (inch)/1005 (mm).

**Applicable Instrument:** 4287A\*, E4982A, 4294A + 42942A, E5061B-3L5 with Opt. E5061B-005 + 16201A, E4991A

When used with 16085B\*: 4263B, 4268A\*, 4279A\*, 4284A\*, 4285A, 4288A\*, E4980A, E4981A

\* denotes the instrument is obsolete.

**Frequency:** DC to 3 GHz

**Maximum Voltage:**  $\pm 42$  V peak max. (AC +DC)

**Operating Temperature:** -55°C to +85 °C

**DUT size:** The applicable SMD size is 0402 (inch) /1005 (mm). For details, see the figure below.

The 16196B is furnished with three different insulator assemblies, since any gaps between the DUT and the cylindrical insulator will

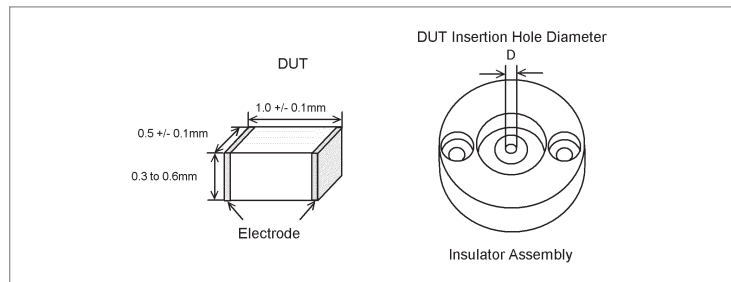

result in improper positioning and subsequent measurement errors. Select an insulator assembly that reduces the gap the most. See the table below for dimensions of the insulator assemblies.

	Hole Diameter of Insulator assembly (mm)	SMD case size examples Length, Width, Height (mm)
16196B	$\Phi$ 0.85	1.0 x 0.5 x 0.5
	$\Phi$ 0.75	1.0 x 0.5 x 0.35
	$\Phi$ 0.68	1.0 x 0.5 x 0.35

### Furnished Accessories:

Description	P/N	Qty.
Operation and Service Manual	16196-90040	1
Insulator Assembly $\Phi$ 0.85 mm	16196-60212	1
Insulator Assembly $\Phi$ 0.75 mm	16196-60213	1
Insulator Assembly $\Phi$ 0.68 mm	16196-60214	1
Open Plate	16196-29002	1
Short Plate	16196-29027	1
Push Ring	16196-24004	1
Magnifying Lens <sup>1</sup>	16193-60002	1
Tweezers <sup>1</sup>	8710-2081	1
Wrench	8710-0909	1
Cleaning Rod	5182-7586	1
Carrying Case	16196-60250	1

1: Opt. 16196B-710 only

**Options:**

16196B-710: Add the magnifying lens and tweezers

To maintain adequate measurement performance, keep the electrodes and the short plate in good condition. Contaminants and abrasion on these parts considerably affect measurement results, especially for low value measurements. Periodic fixture cleaning and part replacement is recommended to avoid deterioration of measurement performance. The 16196x fixtures are designed with simplicity in mind, so that an operator can easily replace parts. Spare parts, which are likely to be abraded, are supplied with the 16196U Maintenance Kit.

**16196U Maintenance Kit**

Opt. 16196U-010: Upper electrode, 5 piece set (common to 16196A/B/C models)

Opt. 16196U-200: Short plate for 0402 (inch)/1005 (mm) size, 5 piece set (for 16196B)

Opt. 16196U-210: Lower electrode, 5 piece set (for 16196B)

**Compensation and Measurement:** First of all, install the appropriate insulator assembly into the fixture. Then, perform compensation. Open and short compensations are recommended in combination with the electrical length compensation before measurement. The fixture's electrical length must be entered into the electrical length compensation function of the measurement instrument first. Next, open compensation is performed by placing the furnished open plate on top of the insulator assembly. Short compensation is performed by placing the furnished shorting plate on top of the insulator assembly. After performing open and short compensations in combination with the electrical length compensation, the DUT is inserted into the test fixture. Once the measurement of the DUT is complete, remove the DUT from the fixture, by using the furnished push ring. Refer to the 16196A figures to see how compensation and measurement is performed.

## Up to 3 GHz (7 mm) SMD

### 16196C Parallel Electrode SMD Test Fixture

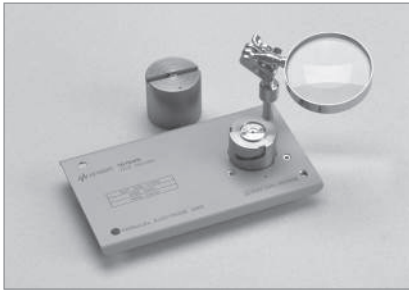

**Terminal Connector:** 7 mm

**DUT Connection:** 2-Terminal

**Electrical Length:** 27.1 mm

**Dimensions (approx.):** 140(W) x 48(H) x 78(D) [mm]

**Weight (approx.):** 250 g

**Additional Error:**

Type of Error	Impedance
Proportional Error	$1.0 \times f^2$ [%]
Open Repeatability	$5 + 40 \times f$ [ $\mu$ S]
Short Repeatability	$30 + 125 \times f$ [m $\Omega$ ]

f: frequency [GHz]

**Description:** This test fixture is designed for impedance evaluations of parallel electrode SMDs. It achieves stable frequency characteristics up to 3 GHz and provides highly repeatable measurements. The applicable SMD size code is 0201 (inch)/0603 (mm).

**Applicable Instrument:** 4287A\*, E4982A, 4294A + 42942A, E5061B-3L5 with Opt. E5061B-005 + 16201A, E4991A

When used with 16085B\*: 4263B, 4268A\*, 4279A\*, 4284A\*, 4285A, 4288A\*, E4980A, E4981A

\* denotes the instrument is obsolete.

**Frequency:** DC to 3 GHz

**Maximum Voltage:**  $\pm 42$  V peak max. (AC +DC)

**Operating Temperature:** -55°C to +85°C

**DUT size:** The applicable SMD size is 0201 (inch)/0603 (mm). For details, see the figure below.

The 16196C is furnished with one insulator assembly. See the table below for the dimensions of the insulator assembly.

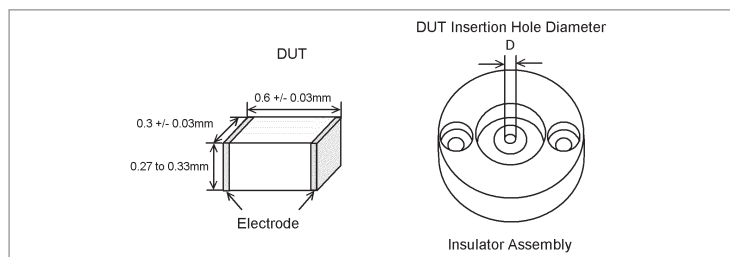

	Hole Diameter of Insulator assembly (mm)	SMD case size examples Length, Width, Height (mm)
16196C	$\Phi$ 0.48	0.6 x 0.3 x 0.3

#### Furnished Accessories:

Description	P/N	Qty.
Operation and Service Manual	16196-90040	1
Insulator Assembly $\Phi$ 0.48 mm	16196-60312	1
Open Plate	16196-29002	1
Short Plate	16196-29028	1
Push Ring	16196-24004	1
Magnifying Lens <sup>1</sup>	16193-60002	1
Tweezers <sup>1</sup>	8710-2081	1
Wrench	8710-0909	1
Cleaning Rod	5182-7586	1
Carrying Case	16196-60350	1

#### Options:

1: Opt. 16196C-710 only

16196C-710: Add the magnifying lens and tweezers

To maintain adequate measurement performance, keep the electrodes and the short plate in good condition. Contaminants and abrasion on these parts considerably affect measurement results, especially for low value measurements. Periodic fixture cleaning and part replacement is recommended to avoid deterioration of measurement performance. The 16196x fixtures are designed with simplicity in mind, so that an operator can easily replace parts. Spare parts, which are likely to be abraded, are supplied with the 16196U Maintenance Kit.

**16196U Maintenance Kit**

Opt. 16196U-010: Upper electrode, 5 piece set (common to 16196A/B/C models)

Opt. 16196U-300: Short plate for 0201 (inch)/0603 (mm) size, 5 piece set (for 16196C)

Opt. 16196U-310: Lower electrode, 5 piece set (for 16196C)

**Compensation and Measurement:** Open and short compensations are recommended in combination with the electrical length compensation before measurement. The fixture's electrical length must be entered into the electrical length compensation function of the measurement instrument first. Next, open compensation is performed by placing the furnished open plate on top of the insulator assembly. Short compensation is performed by placing the furnished shorting plate on top of the insulator assembly. After performing open and short compensations in combination with the electrical length compensation, the DUT is inserted into the test fixture. Once the measurement of the DUT is complete, remove the DUT from the fixture, by using the furnished push ring. Refer to the 16196A figures to see how compensation and measurement is performed.

## Up to 3 GHz (7 mm) SMD

### 16196D Parallel Electrode SMD Test Fixture



**Terminal Connector:** 7 mm

**DUT Connection:** 2-Terminal

**Electrical Length:** 27.3 mm

**Dimensions (approx.):** 140(W) x 48(H) x 78(D) [mm]

**Weight (approx.):** 250 g

**Additional Error:**

Type of Error	Impedance
Proportional Error	$1.0 \times f^2$ [%]
Open Repeatability	$5 + 40 \times f$ [ $\mu$ S]
Short Repeatability	$30 + 125 \times f$ [m $\Omega$ ]

f: frequency [GHz]

**Description:** This test fixture is designed for impedance evaluations of parallel electrode SMDs. It achieves stable frequency characteristics up to 3 GHz and provides highly repeatable measurements. The applicable SMD size code is 01005 (inch)/0402 (mm).

**Applicable Instrument:** 4287A\*, E4982A, 4294A + 42942A, E5061B-3L5 with Opt. E5061B-005 + 16201A, E4981A

\* denotes the instrument is obsolete.

**Frequency:** DC to 3 GHz

**Maximum Voltage:**  $\pm 42$  V peak max. (AC +DC)

**Operating Temperature:** -55°C to +85 °C

**DUT size:** The applicable SMD size is 01005 (inch) /0402 (mm). For details, see the figure below.

The 16196D is furnished with two different insulator assemblies, since any gaps between the DUT and the cylindrical insulator will result in improper positioning and subsequent measurement errors. Select an insulator assembly that reduces the gap the most. See the

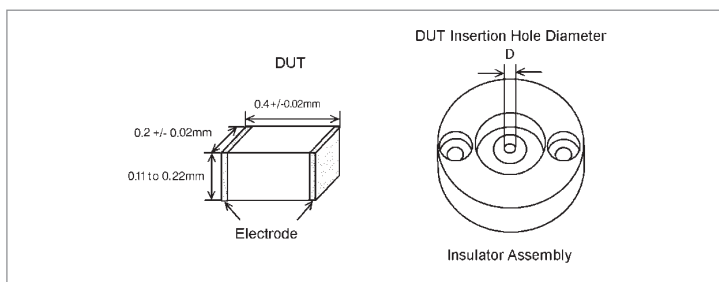

table below for dimensions of the insulator assemblies.

	Hole Diameter of Insulator assembly (mm)	SMD case size examples Length, Width, Height (mm)
16196D	$\Phi$ 0.34	0.4 x 0.2 x 0.2
	$\Phi$ 0.30	0.4 x 0.2 x 0.13/0.2

#### Furnished Accessories:

Description	P/N	Qty.
Operation and Service Manual	16196-90040	1
Insulator Assembly $\Phi$ 0.34 mm	16196-60412	1
Insulator Assembly $\Phi$ 0.30 mm	16196-60414	1
Open Plate	16196-29002	1
Short Plate	16196-29030 <sup>2</sup>	1
Push Ring	16196-24004	1
Magnifying Lens <sup>1</sup>	16193-60002	1
Tweezers <sup>1</sup>	8710-2081	1
Wrench	8710-0909	1
Cleaning Rod	5182-7586	1
Carrying Case	16196-60450	1

1: Opt. 16196D-710 only

2: 16196-15101 as replacement part number



**Options:**

16196D-710: Add the magnifying lens and tweezers

To maintain adequate measurement performance, keep the electrodes and the short plate in good condition. Contaminants and abrasion on these parts considerably affect measurement results, especially for low value measurements. Periodic fixture cleaning and part replacement is recommended to avoid deterioration of measurement performance. The 16196x fixtures are designed with simplicity in mind, so that an operator can easily replace parts. Spare parts, which are likely to be abraded, are supplied with the 16196U Maintenance Kit.

**16196U Maintenance Kit**

Opt. 16196U-020: Upper electrode, 5 piece set for 16196D

Opt. 16196U-400: Short plate for 01005 (inch)/0402 (mm) size, 5 piece set (for 16196D)

Opt. 16196U-410: Lower electrode, 5 piece set (for 16196D)

**Compensation and Measurement:** First of all, install the appropriate insulator assembly into the fixture. Then, perform compensation. Open and short compensations are recommended in combination with the electrical length compensation before measurement. The fixture's electrical length must be entered into the electrical length compensation function of the measurement instrument first. Next, open compensation is performed by placing the furnished open plate on top of the insulator assembly. Short compensation is performed by placing the furnished shorting plate on top of the insulator assembly. After performing open and short compensations in combination with the electrical length compensation, the DUT is inserted into the test fixture. Once the measurement of the DUT is complete, remove the DUT from the fixture, by using the furnished push ring. Refer to the 16196A figures to see how compensation and measurement is performed.

# Up to 3 GHz (7 mm) SMD

## 16197A Bottom Electrode SMD Test Fixture

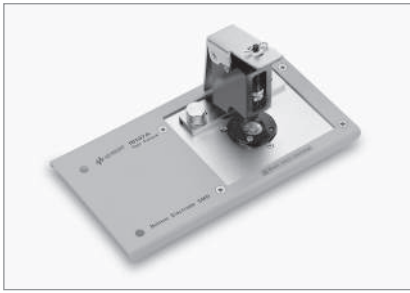

**Terminal Connector:** 7 mm  
**DUT Connection:** 2-Terminal  
**Electrical Length:** 14 mm  
**Dimensions (approx.):** 160(W) x 70(H) x 86(D) [mm]  
**Weight (approx.):** 300 g  
**Additional Error:**

Type of Error	Impedance
Proportional Error	$1.0 \times f^2$ [%]
Open Repeatability	$5 + 40 \times f$ [ $\mu$ S]
Short Repeatability	$30 + 125 \times f$ [m $\Omega$ ]

f: frequency [GHz]



E4991A with 16197A

**Description:** This test fixture is designed for impedance evaluations of bottom electrode SMDs. It achieves stable frequency characteristics up to 3 GHz and provides highly repeatable measurements. This test fixture supports various SMD sizes, as small as 1005 (mm)/0402 (inch) and as large as 3225 (mm)/1210 (inch). Accommodation of the 0603 (mm)/0201 (inch) size is available with option 001.

**Applicable Instrument:** 4287A\*, E4982A, 4294A + 42942A, E5061B-3L5 with Opt. E5061B-005 + 16201A, E4991A

When used with 16085B\*: 4263B, 4268A\*, 4279A\*, 4284A\*, 4285A, 4288A\*, E4980A, E4981A

\* denotes the instrument is obsolete.

**Frequency:** DC to 3 GHz

**Maximum Voltage:**  $\pm 42$  V peak max. (AC +DC)

**Operating Temperature:** -55°C to +85°C

**DUT size:** See figure and table below:

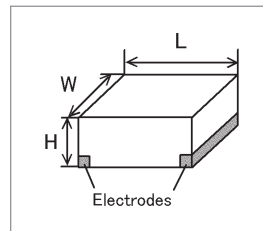

Standard Option	Applicable SMD size	
SMD Size Code	L x W [mm]	H [mm]
3225 (mm)/1210 (inch)	$(3.2 \pm 0.15) \times (2.5 \pm 0.15)$	$H \geq 0.4$
3216 (mm)/1206 (inch)	$(3.2 \pm 0.15) \times (1.6 \pm 0.15)$	$H \geq 0.4$
2012 (mm)/0805 (inch)	$(2.0 \pm 0.15) \times (1.25 \pm 0.15)$	$H \geq 0.4$
1608 (mm)/0603 (inch)	$(1.6 \pm 0.15) \times (0.8 \pm 0.15)$	$H \geq 0.4$
1005 (mm)/0402 (inch)	$(1.0 \pm 0.1) \times (0.5 \pm 0.1)$	$H \geq 0.4$

Option 16197A-001	Applicable SMD size	
SMD Size Code	L x W [mm]	H [mm]
0603 (mm)/0201 (inch)	$(0.6 \pm 0.03) \times (0.3 \pm 0.03)$	$H \geq 0.25$

### Furnished Accessories:

Description	P/N	Qty.
Operation and Service Manual	16197-90000	1
Device Guide <sup>1</sup>	16197-25005	2
Electrode Plate <sup>2</sup>	16197-00603	1
Cleaning Rod	5182-7586	1
Blank Device Guide	16197-25006	3
Magnifying Glass	16193-60002	1
Tweezers	8710-2081	1
Wrench	8710-0909	1
Carrying Case	16197-60060	1

1: One is delivered attached to the test fixture

2: Delivered attached to the fixture

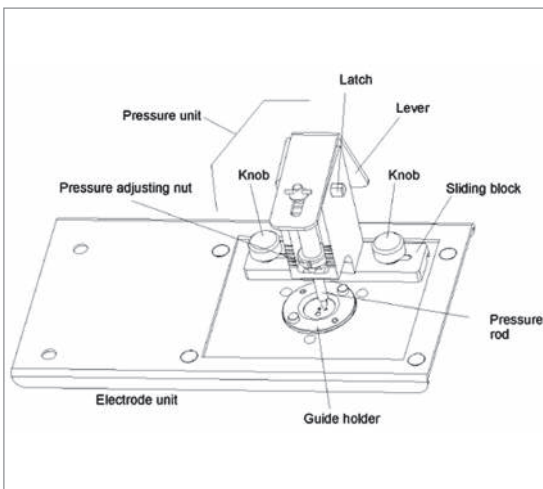

Test fixture overview

EIA/EIAJ Size Shorting Bar Set (Furnished)

Size	P/N	Qty.
1 x 0.5 x 0.5 (mm)	16191-29005	1
1.6 x 0.8 x 0.8 (mm)	16191-29006	1
2.0 x 1.2 x 0.8 (mm)	16191-29007	1
3.2 x 1.6 x 0.8 (mm)	16191-29008	1
Device Guide	16197-25007	1
Electrode Plate	16197-00604	1

16197A-001 Shorting Bar

Size	P/N	Qty.
0.6 x 0.3 x 0.3 (mm)	16197-29001	4

Options:

16197A-001: Add 0603 (mm)/0201 (inch) Device Guide Set

The 16197A's electrode spaces are 0.5 mm, 1 mm, 1.5 mm and 2 mm and the device guide matches these spaces with appropriate insertion holes for the applicable SMD. The 0.2 mm electrode spacing is available with option 001, which includes a device guide with 0603 mm/0201inch insertion holes, an electrode plate and 4 shorting devices.

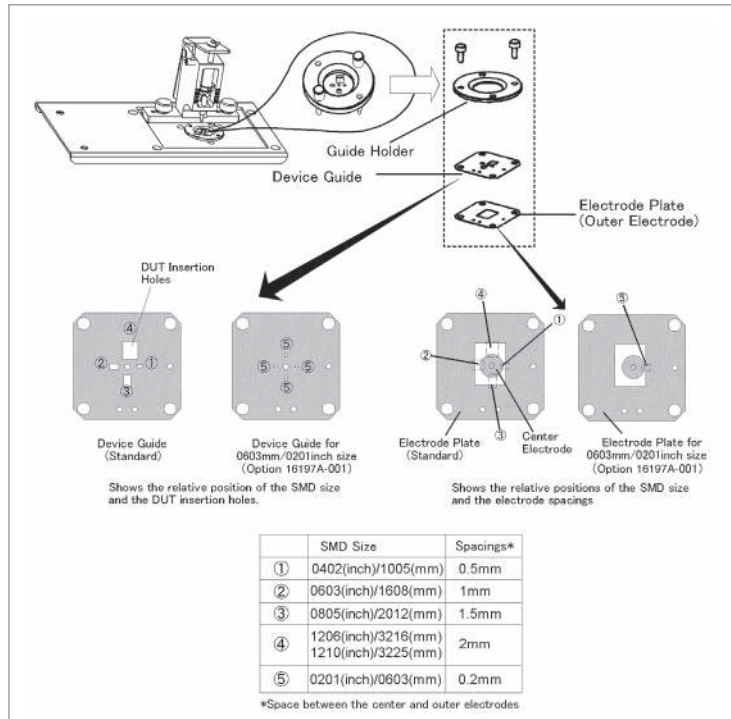

Electrodes configuration and SMD size

**Compensation and Measurement:** First of all, select the appropriate device insertion hole. If the device insertion hole is not positioned in the pressure arm's contact range, reposition the device guide and the electrode plate. Once this is prepared, perform compensation. Open and short compensations are recommended in combination with the electrical length compensation before measurement. The fixture's electrical length must be entered into the electrical length

## Up to 3 GHz (7 mm) SMD

compensation function of the measurement instrument first. Next, open compensation is performed by not placing anything in the device insertion hole. Short compensation is performed by placing the furnished shorting device in the device insertion hole. After performing open and short compensations in combination with the electrical length compensation, the DUT is inserted into the device insertion hole. Once the measurement of the DUT is complete, remove the DUT from the fixture. The following figures show how compensation and measurement is performed.

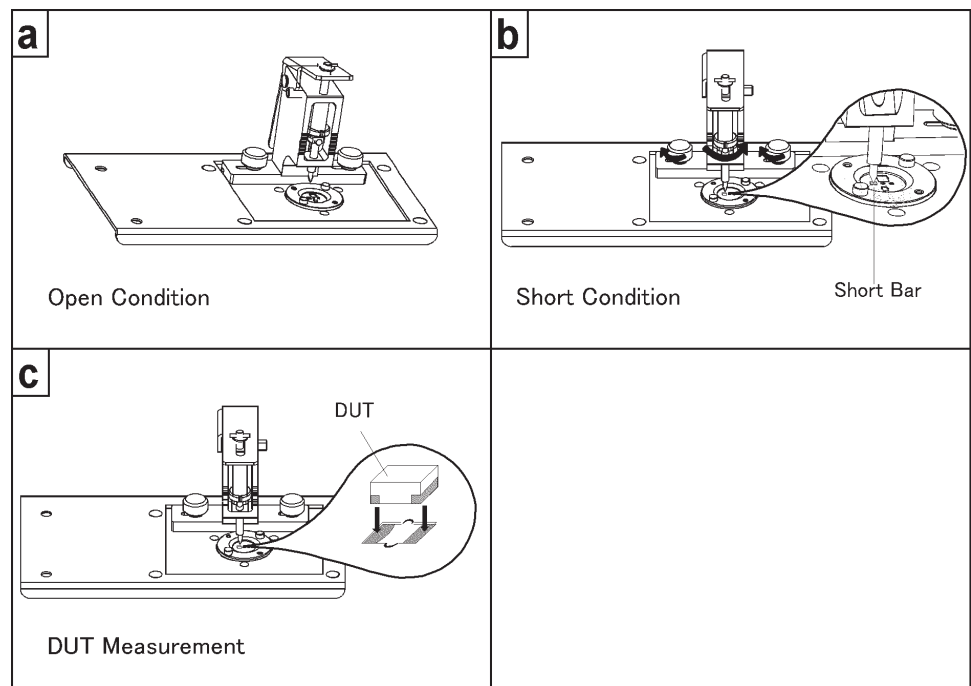

Compensation and measurement

## Up to 3 GHz (7 mm) DC Bias Accessories

### 16200B External DC Bias Adapter



**Terminal Connector:** 7 mm

**DC BIAS Input connector:** BNC(f)

**Voltage Monitor connector:** BNC(f)

**Dimensions (approx.):** 170(W) x 70 (H) x 130(D) [ mm]

**Weight (approx.):** 900 g

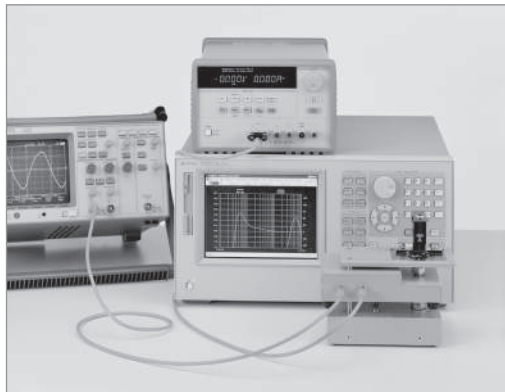

Connection example

**Description:** This test fixture is designed to measure a DUT with DC bias. By connecting an external DC current source to the 16200B, it can supply a bias current across the DUT of up to  $\pm 5$  Adc through a 7 mm port.

**Applicable Instruments:** (4291B\*, 4294A + 42942A, 4287A\*, E4982A, E5061B-3L5 with Opt. E5061B-005 + 16201A, E4991A)\*\*

When used with 16085B\*: 4279A\*, (4284A\*, 4285A, 4288A\*, E4980A, E4981A)

\* denotes the instrument is obsolete.

\*\* applicable in a limited frequency range.

**Frequency:** 1 MHz to 1 GHz

**DC Bias:** Up to 5A, 40 V (Input)

**Operating Temperature:** 0°C to 55°C

**Applicable Fixtures:** 16191A\*, 16192A, 16193A\*, 16194A, 16196A/B/C/D, 16197A, 16092A, 16093A/B\*

\* denotes the instrument is obsolete.

#### Furnished Accessories:

Description	P/N	Qty.
Operation and Service Manual	13200-90011	1

#### 16200B-001 Shorting Device Set

Size	P/N	Qty.
0.6 x 0.3 x 0.3 (mm)	16197-29001	2
1 x 0.5 x 0.5 (mm)	16191-29005	2
1.6 x 0.8 x 0.8 (mm)	16191-29006	2
2.0 x 1.2 x 0.8 (mm)	16191-29007	2
3.2 x 1.6 x 0.8 (mm)	16191-29008	2

#### 16200B-001 Load Device Set

Size	P/N	Qty.
0.6 x 0.3 x 0.3 (mm)	0699-6926	5
1 x 0.5 x 0.5 (mm)	5182-0433	5
1.6 x 0.8 x 0.8 (mm)	5182-0434	5
2.0 x 1.2 x 0.8 (mm)	5182-0435	5
3.2 x 1.6 x 0.8 (mm)	5182-0436	5

#### Options:

16200B-001: Add Working Std Set

**Compensation and Measurement:** When using the 4291B, follow these instructions: Perform open, short, load and low-loss calibration at the 7 mm test port of the 4291B. Connect the 16200B to the 7 mm test port, and connect the test fixture onto the 16200B. Open, short, and load compensations are recommended before measurement. Use the short bars and 51  $\Omega$  SMD resistors furnished with 16200B-001 to perform short and load compensation respectively.

When using other instruments, follow these instructions:

Connect the 16200B to the 7 mm test port of the measurement instrument. Perform open, short, load (and low-loss calibration) at the 7 mm test port of the 16200B. Then, connect the test fixture onto the 16200B and perform open, short, and electrical length compensations in the usual manner.

## Up to 3 GHz (7 mm) Material

### 16453A Dielectric Material Test Fixture



**Terminal Connector:** 7 mm

**Dimensions (approx.):** 130(H) x 50(W) x 60(D) [mm]

**Weight (approx.):** 600 g

**Measurement Accuracy (including the E4991A):**

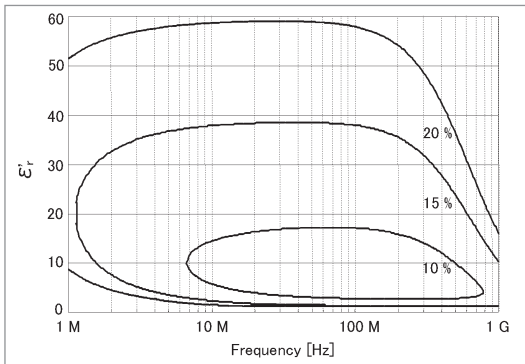

Typical Permittivity ( $\epsilon_r'$ ) Measurement Accuracy  
(@ thickness = 1 mm)

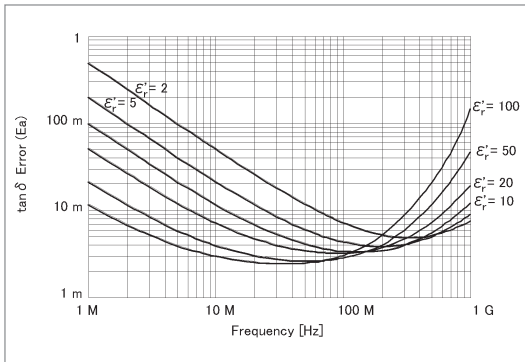

Typical Loss Tangent ( $\tan \delta$ ) Measurement Accuracy  
(@ thickness = 1 mm)



E4991A with 16453A

**Description:** The 16453A is designed for accurate dielectric constant and loss tangent measurements on the E4991A. It employs the parallel plate method, which sandwiches the material between two electrodes to form a capacitor. E4991A measures the capacitance created from the fixture, and option E4991A-002 firmware calculates the relative complex permittivity. Adjustment to insure parallel electrodes is required when using the 16451B. This adjustment is not required with 16453A because the fixture has a flexible electrode that adjusts automatically to the material surface.

**Applicable Instruments:** (E4991A with Opt. E4991A-002, 4291B\* with Opt. 4291B-002)\*\*

\* denotes the instrument is obsolete.

\*\* applicable in a limited frequency range.

**Frequency:** 1 MHz to 1 GHz

**Maximum Voltage:**  $\pm 42$  V peak max. (AC+DC)

**Operating Temperature:**  $-55^{\circ}\text{C}$  to  $200^{\circ}\text{C}$

When Option E4991A-007 temperature characteristic test kit is used with E4991A, the operating temperature range is between  $-55^{\circ}\text{C}$  and  $+150^{\circ}\text{C}$ .

**Material Size:**

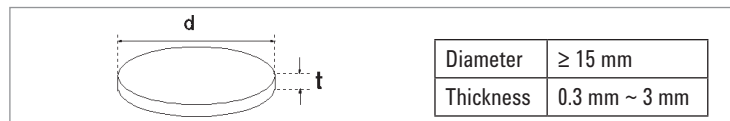

**Furnished Accessories:**

Description	P/N	Qty.
Fixture Holder	16453-01213	1
Load	16453-60021	1
Tweezers	8710-2081	1
Carrying Case	16453-60011	1
Operation and Service Manual	16453-90010	1

**Compensation and Measurement:** Open, short and load compensations are recommended before measurement. Open compensation is performed by separating the high and the low electrodes from each other. Short compensation is performed by connecting the high and low electrodes together. Load compensation is performed by using the furnished load material. After performing open, short and load compensations, the material under test is inserted into the test fixture.

# Up to 3 GHz (7 mm) Material

## 16454A Magnetic Material Test Fixture



**Terminal Connector:** 7 mm

**Dimensions (approx.):**

(Large Test Fixture)	30(D) x 35(H) [mm]
(Small Test Fixture)	24(D) x 30(H) [mm]

**Weight (approx.):**

(Large Test Fixture)	140 g
(Small Test Fixture)	120 g

**Measurement Accuracy (typical.):**

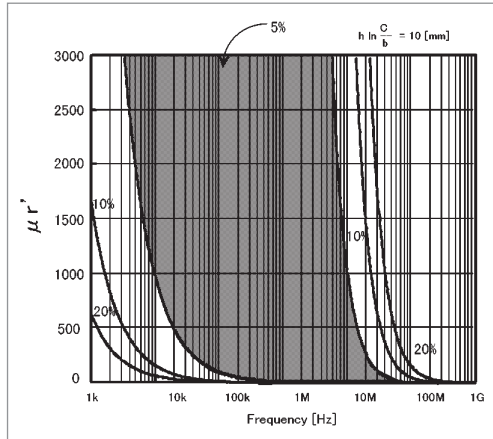

Typical Permeability ( $\mu_r$ ) Measurement Accuracy (@  $h^* \ln c/b = 10$ )

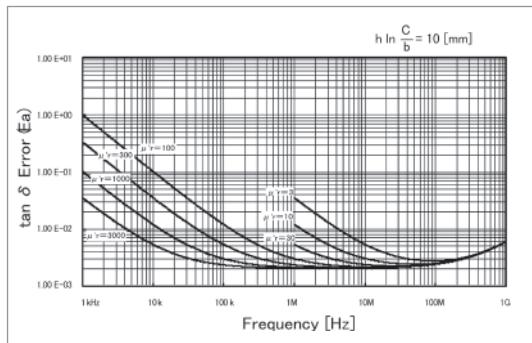

Typical Loss Tangent ( $\tan \delta$ ) Measurement Accuracy (@  $h^* \ln c/b = 10$ )

**Description:** The 16454A is designed for accurate permeability measurements of toroidal-shaped magnetic materials. Since the construction of this fixture creates one turn around the toroid (with no magnetic flux leakage), the need of winding a wire around the toroid is unnecessary. The following figure shows the one-turn mechanism and how complex permeability is calculated from it.

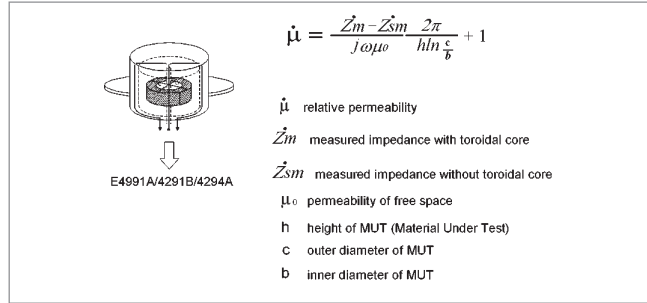

Permeability measurement method of 16454A

Complex permeability is calculated from the inductance with and without the toroid. When E4991A with option E4991A-002 is used as the measurement instrument, direct readouts of complex permeability are possible. In addition, it is furnished with a small and a large fixture to adapt to a wide range of sizes.

**Applicable Instruments:** (4294A + 42942A, E4991A with Opt. E4991A-002, 4291B\* with Opt. 4291B-002\*)\*\*

\* denotes the instrument is obsolete.

\*\* applicable in a limited frequency range.

**Frequency:** 1 kHz to 1 GHz,

**DC Bias:** -500 mA to +500 mA (max)

**Operating Temperature:** -55°C to 200°C

When Option E4991A-007 temperature characteristic test kit is used with E4991A, the operating temperature range is between -55°C and +150°C. The temperature characteristic test kit is unavailable for the 4294A.

**Material Size:** See figure below.

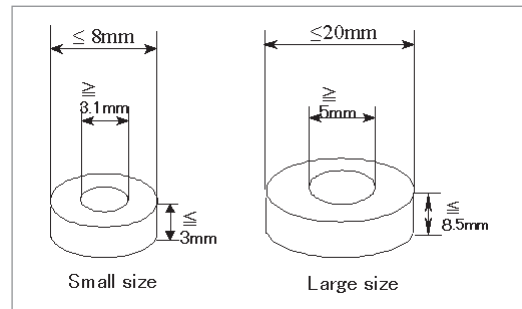

Material size

# Up to 3 GHz (7 mm) Material



E4991A with 16454A

## Furnished Accessories:

Description	P/N	Qty.
Fixture Holder	16454-00601	1
Tweezers	8710-2081	1
Screw, Hex Recess	0515-1050	1
Holder A	16454-25002	1
Holder B	16454-25001	1
Holder C (Without hole)	16454-25003	1
Holder D (Without hole)	16454-25004	1
Holder Case	1540-0622	1
Hex Key (for replacing fixtures)	8710-1181	1
Carrying Case	16454-60101	1
Operation and Service Manual	16454-90020	1

**Compensation and Measurement:** Short compensation is required before measurement. Short compensation is performed by only inserting the MUT holder into the test fixture. After performing short compensation, the MUT is inserted into the fixture as shown below.

## Short Compensation

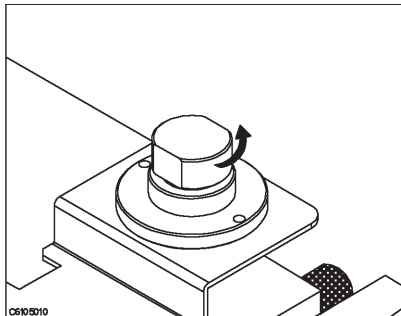

Remove the cap of the fixture

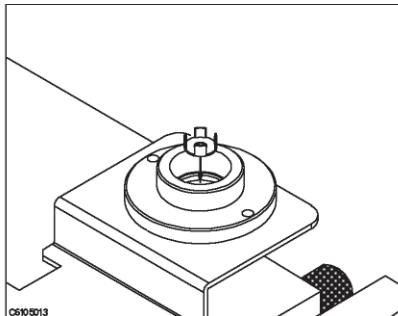

Place a MUT holder only in the fixture

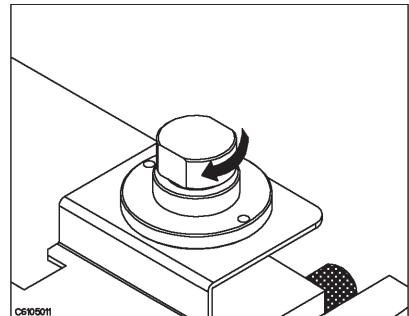

Replace the cap by screwing tightly

## Placing the MUT on the Test Fixture as follows:

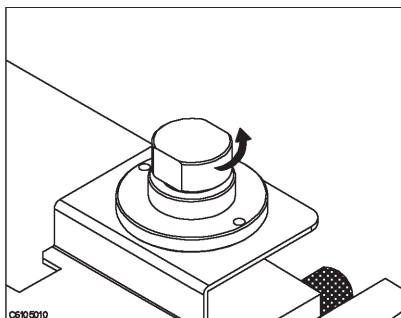

Remove the cap of the fixture

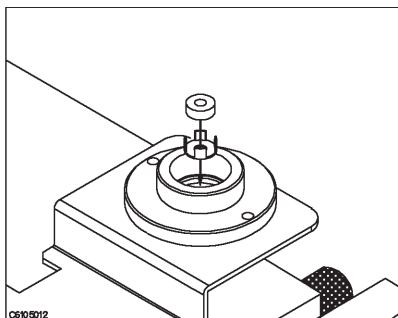

Place a MUT onto the MUT holder and insert it into the fixture.

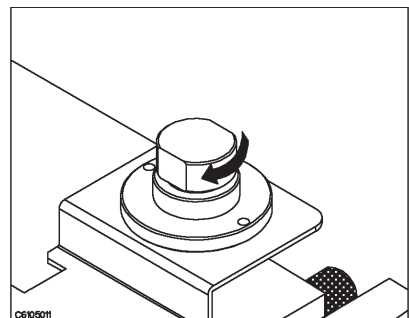

Replace the cap by screwing tightly



# DC (High resistance)

## Test Fixtures for DC (High Resistance) Measurements

Test Fixture	Frequency	Applicable Instrument
16339A	DC	4339B
16118A	DC	4339B
16117B/C	DC	4349B
16008B	DC	4339B

### Applicable Instrument

Frequency  
Range

Up to 110 MHz  
(Terminal Configuration: 4-Terminal Pair)

Up to 3 GHz  
(Terminal Configuration: 7 mm)

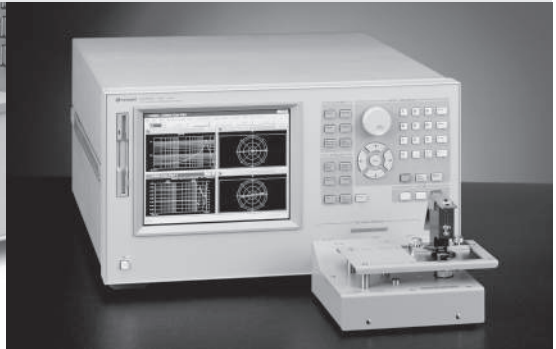
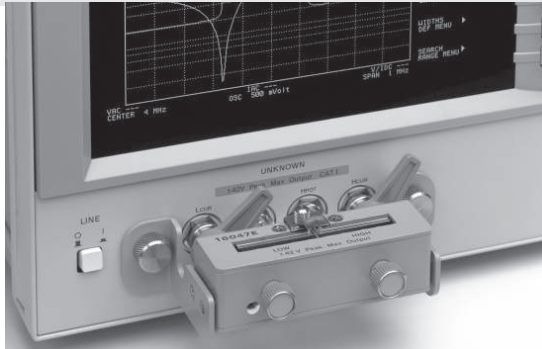

Measurement  
Instruments

4263B, 4268A, 4279A, 4284A,  
4285A, 4288A, 4294A, E4980A, E4981A

4291B, 4294A + 42942A, E5061B-3L5 w/Opt. 005 + 16201A,  
4287A, E4982A, E4991A  
Any 4TP instruments (excluding 4294A) +16085B

Frequency

DC (High Resistance Measurement)



Measurement  
Instruments

4339B, 4349B

# DC (High resistance) SMD & Lead Components

## 16339A Component Test Fixture

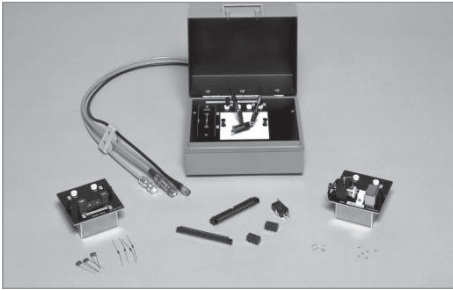

### Terminal Connector:

Type	Connector
Input	Triaxial (special screw-type)
Output	High Voltage BNC (special type)
Control	Interlock connector*

\* Interlock Connector enables and disables the application of source voltage from the measurement instrument.

**DUT Connection:** 2-Terminal (with triaxial cable)

**Dimensions (approx.):** 200(W) x 140(H) x 230 (D) [mm]

**Cable Length (approx.):** 0.8 m

**Weight (approx.):** 2200 g

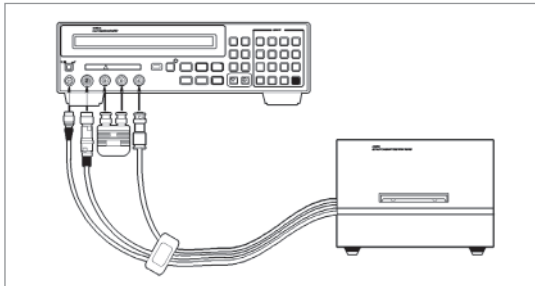

4339B with 16339A

**Description:** The 16339A is designed to operate specifically with 4339B. It is provided with three component modules, which are used to hold SMD, lead and various type of devices. Electrical noise effects are reduced by the employment of a shielded case. A built-in interlocking circuit enables safe high-voltage measurements.

**Applicable Instruments:** 4339B\*

\* denotes the instrument is obsolete.

**Frequency:** DC

**Maximum Voltage:** 1000 V

**Maximum Current:** 10 mA

**Resistance Measurement Range:**  $1 \times 10^3$  to  $2 \times 10^{16} \Omega$

**Operating Temperature:** 0°C to 55°C

**DUT Size:** For Alligator Clip and Flat Table, lead diameter  $\leq 5$  mm

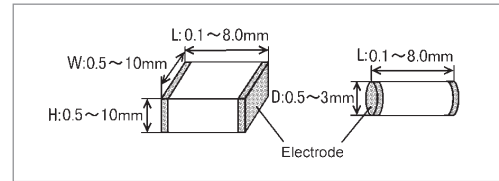

SMD module

### Furnished Accessories:

Description	P/N	Qty.
Axial Lead Module	16339-60102	1
SMD Module	16339-60101	1
Flat Table	16339-6004	1
Miniature Banana-Plug cable	16339-61621	2
100 kΩ Output Resistor	16339-61001	1
1 MΩ Output Resistor	16339-61002	1
10 MΩ Output Resistor	16339-61003	1
100 MΩ Output Resistor	16339-61004	1
Alligator Clip	8710-1984	2
Carrying Case	16339-600201	1
Operation and Service Manual	16339-90010	1

**Compensation and Measurement:** Open compensation is recommended before measurement. When using the axial lead module, have no DUT connected to the electrodes. When using the SMD module, separate the high and low electrodes from each other. The separation should be equivalent in size to the DUT's width. When using the alligator clip and flat table, remove the alligator clips from the input terminals of the test fixture. After preparing the open condition of the respective module, close the top cover and then perform open compensation. Finally, the DUT is inserted into the respective module. The following figure shows the three component modules.

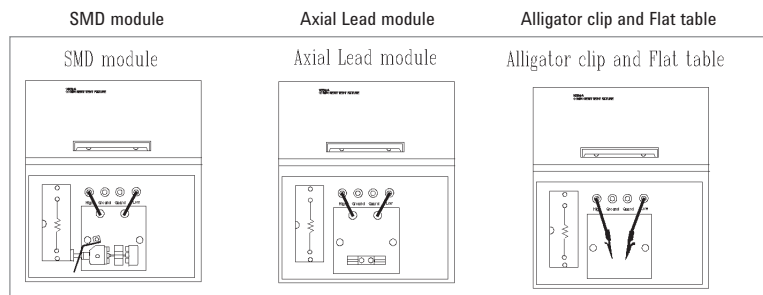

Component module configurations

## DC (High resistance) SMD

### 16118A Tweezers Test Fixture



#### Terminal Connector:

Type	Connector
Input	Triaxial (special screw-type)
Output	High Voltage BNC (special type)
Control	Interlock connector*

\* Interlock Connector enables and disables the application of source voltage from the measurement instrument.

**DUT Connection:** 2-Terminal (with triaxial cable)

**Cable Length (approx.):** 1 m

**Weight (approx.):** 410 g

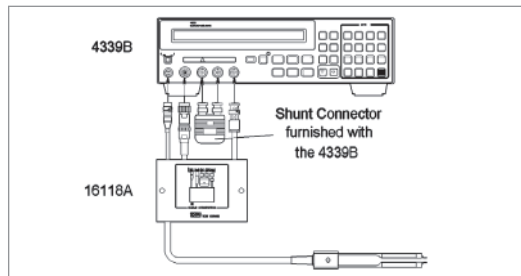

4339B with 16118A

**Description:** The 16118A is designed to operate specifically with 4339B. The tweezer's contacts, makes it easy to hold SMD. Electrical noise effects are reduced by the employment of shielded-cables. A built-in interlocking circuit enables safe high-voltage measurements.

**Applicable Instruments:** 4339B\*

\* denotes the instrument is obsolete.

**Frequency:** DC

**Maximum Voltage:** 100 V

**Maximum Current:** 0.87 mA

**Resistance Measurement Range:**  $1 \times 10^7$  to  $1 \times 10^{11} \Omega$

**Operating Temperature:** 0°C to 55°C

**DUT Size:** See figure below

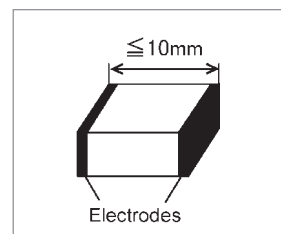

#### Furnished

#### Accessories:

Description	P/N	Qty.
Operation and Service Manual	16118-90010	1

**Compensation and Measurement:** Open compensation is recommended before measurement. Separate the electrodes from each other. The separation should be equivalent in size to the DUT's width. After performing open compensation, the DUT is sandwiched by the tweezers' contacts and is measured.

## DC (High resistance) Other Components

### 16117B Low Noise Test Leads

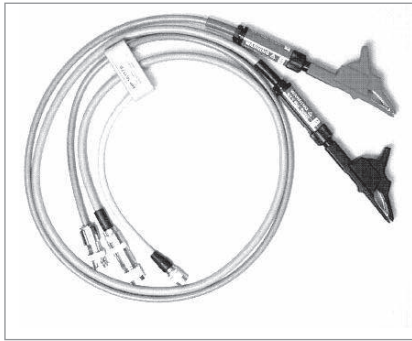

#### Terminal Connector:

Type	Connector
Input	Triaxial (special screw-type)
Output	High Voltage BNC (special type)
Control	Interlock connector*

\* Interlock connector enables and disables the application of source voltage from the measurement instrument.

**DUT Connection:** 2-Terminal (with triaxial cable)

**Cable Length (approx.):** 1 m (connector to clips)

**Weight (approx.):** 280 g

**Description:** The 16117B is designed to operate specifically with 4339B. With 16117B-003 wide jaw clips, it is capable of holding DUTs with large terminals. The clips can be replaced with probes (16117B-001) for measurements of small DUTs such as PC boards or IC sockets. 16117B-002 enables the construction of simple custom-made test leads. Electrical noise effects are reduced by the employment of shielded-cables. A built-in interlocking circuit enables safe high-voltage measurements.

**Applicable Instruments:** 4339B\*

\* denotes the instrument is obsolete.

**Frequency:** DC

**Maximum Voltage:** 1000 V

**Maximum Current:** 0.5 mA

**Resistance Measurement Range:**  $1 \times 10^3$  to  $1 \times 10^{11} \Omega$

**Operating Temperature:** 0°C to 55°C

**DUT Size:** For clips (16117B-003), lead diameter  $\leq 30$  mm  
For probes and sockets, see figure below:

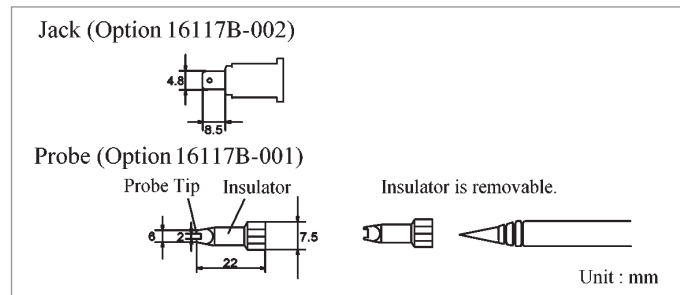

#### Furnished Accessories:

Description	P/N	Qty.
Operation and Service Manual	16117-90060	1

#### Options:

16117B-001: Add Pin Probes (2 ea.)

16117B-002: Add Soldering Sockets (2 ea.)

16117B-003: Add Alligator Clips (2 ea.)

**Compensation and Measurement:** Open compensation is recommended before measurement. Separate the test clips (or probes) from each other. After performing open compensation, the DUT is connected to the clips (or probes). The DUT can be measured in two configurations: floating and grounded. The connections are shown in the figure below:

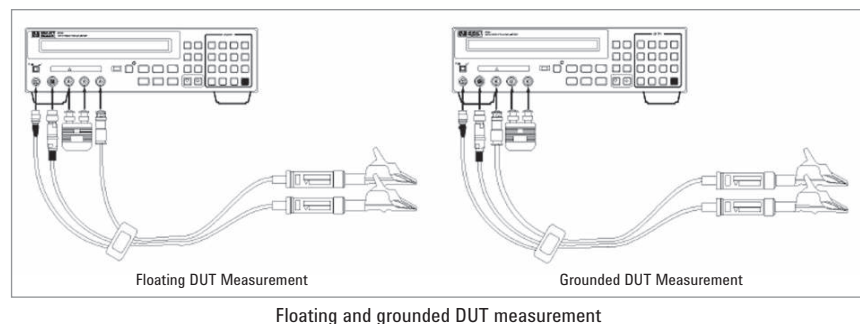

#### Note:

Part number corresponding to Probe/Socket/Clip is as follows:

#### Pin Probes:

8710-2301 (Black),

8710-2302 (Red)

#### Soldering Socket:

1200-1903 (Black),

1200-1904 (Red)

#### Alligator Clip:

8710-2404 (Black),

8710-2405 (Red)

## DC (High resistance) Other Components

### 16117C Low Noise Test Leads



#### Terminal Connector:

Type	Connector
Input	Triaxial (special screw-type)
Output	High Voltage BNC (special type)
Control	Interlock connector*

\* Interlock connector enables and disables the application of source voltage from the measurement instrument.

**DUT Connection:** 2-Terminal (with triaxial cable)

**Cable Length (approx.):** 1 m (connector to connector)

**Weight (approx.):** 290 g

**Description:** The 16117C is designed to operate specifically with 4339B. It comes with a separate triaxial (special screw-type) female connector and a high-voltage BNC (special type) female connector, so that the terminal configuration of the 4339B can be converted to any other configuration. Therefore, custom-made test fixtures can easily be constructed.

**Applicable Instruments:** 4339B\*

\* denotes the instrument is obsolete.

**Frequency:** DC

**Maximum Voltage:** 1000 V

**Maximum Current:** 10 mA

**Resistance Measurement Range:**  $1 \times 10^3$  to  $1 \times 10^{16} \Omega$

**Operating Temperature:** 0°C to 55°C

**Furnished Accessories:**

Description	P/N	Qty.
Triaxial (special screw-type) female connector	1250-2228	1
High Voltage BNC (special type) female connector	1250-2317	1
Operation and Service Manual	16117-90060	1

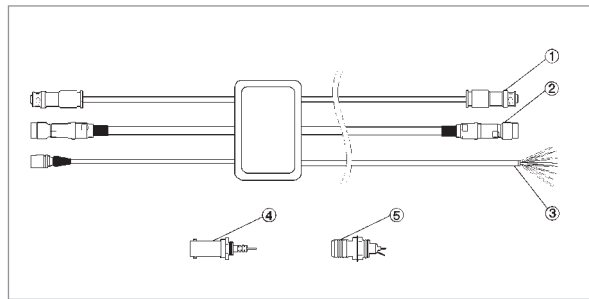

Adapter features

1. High-voltage BNC cable. This connector provides the source voltage to the 16117C. This is a high-voltage BNC connector and is not compatible with standard BNC connectors.
2. Triaxial cable. The measured signal is carried on the center conductor of this connector. This is a special screw-type triaxial connector and is not compatible with standard triaxial connectors.
3. Interlock cable. This connector enables the interlock function which enables and disables the application of source voltage from the 4339B when the interlock line is connected and disconnected respectively.
4. High-voltage BNC (special type) female connector
5. Triaxial (special screw-type) female connector.

# DC (High resistance) Material

## 16008B Resistivity Cell

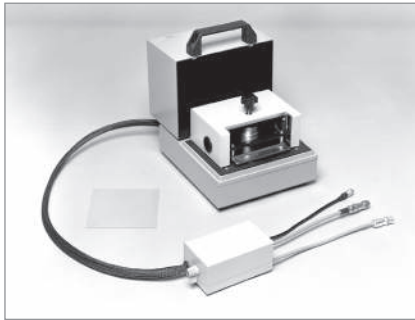

### Terminal Connector:

Type	Connector
Input	Triaxial (special screw-type)
Output	High Voltage BNC (special type)
Control	Interlock connector*

\* Interlock Connector enables and disables the application of source voltage from the measurement instrument.

**DUT Connection:** 2-Terminal (with triaxial cable)

**Dimensions (approx.):** 240(W) x 180(H) x 240(D) [mm]

**Cable Length (approx.):** 1.2 m (connector to electrodes)

**Weight (approx.):** 7000 g

**Description:** The 16008B is designed to operate specifically with 4339B. It is used to measure surface or volume resistance/resistivity of insulation materials. The following figures show the block diagrams of resistivity measurements.

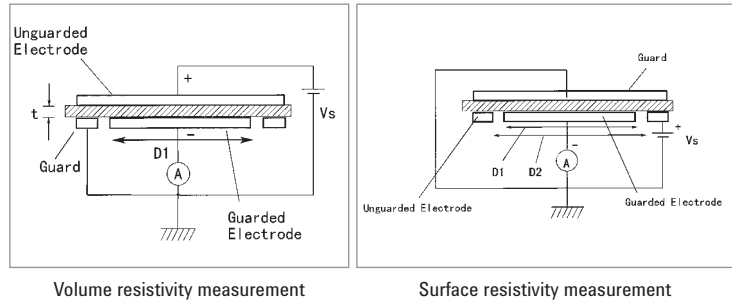

Volume resistivity is measured across the material (MUT) by the unguarded and guarded electrodes. Surface resistivity, on the other hand, is measured along the surface of the MUT (between the guarded and the unguarded electrodes). Notice that the role of the guard and unguarded electrodes switch when measuring volume and surface resistivity. 16008B is provided with three different electrode sizes to meet size requirements by different measurement standards. The guarded electrode eliminates measurement errors due to the edge effect and arbitrary contact pressure can be applied to the material under test. It is also equipped with a high-voltage protection cover to shut off power when opened.

**Applicable Instruments:** 4339B\*

\* denotes the instrument is obsolete.

**Frequency:** DC

**Maximum Voltage:** 1000 V

**Maximum Current:** 10 mA

**Resistance Measurement Range:**

Volume Resistivity Measurement Range:

up to  $4.0 \times 10^{18} \Omega\text{cm}$

Surface Resistivity Measurement Range:

up to  $4.0 \times 10^{17} \Omega$

**Operating Temperature:** -30°C to +100°C (excluding selector switch)

**Material Size:** Select an electrode so that outer diameter of guarding electrode is smaller than the DUT's diameter. See figure and table below for more details:

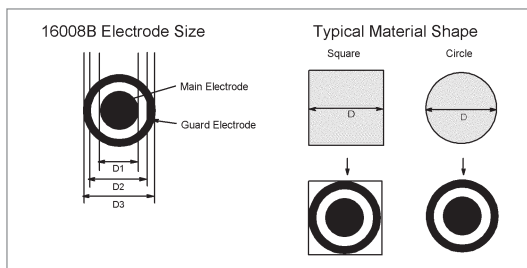

Electrode sizes and applicable material sizes

D1	D2	D3	Ordering information	D
Main Electrode	Guard Electrode (Inner Diameter)	Guard Electrode (Inner Diameter)	-	Material Size
26 mm	38 mm	48 mm	Supplied with 16008B-001/002	50 mm* to 125 mm
50 mm	70 mm	80 mm	Standard - equipped	82 mm* to 125 mm
76 mm	88 mm	98 mm	Supplied with 16008B-001	100 mm* to 125 mm

\* Outer Diameter of Guard Electrode + 2 mm  
Thickness: 10µm to 10 mm

## DC (High resistance) Material

### Furnished Accessories:

Description	P/N	Qty.
Acrylic Plate	16008-1033	1
Operation and Service Manual	16008-90011	1

### Options:

16008B-001: Add 26 & 76 mm diameter electrodes

16008B-002: Add 26 mm diameter electrode

**Compensation and Measurement:** Using the selector switch on the 16008B, select either the volume resistivity or surface resistivity measurement configuration. Open compensation is recommended before measurement and when the measurement configuration is switched. Separate the upper electrode from the main electrode by turning the contact pressure load knob until the distance between the upper electrode and the lower electrode is about 10 mm. Then, close the top cover and perform open compensation. After open compensation, the material under test (MUT) is placed on the main electrode and the upper electrode is placed over it. Next, turn the load knob to adjust the electrode contact pressure on the MUT. Close the top cover and measure the MUT's surface or volume resistivity.

It is vital to make measurements, which are compatible to a certified test method (standard). It is shown below that the 16008B can make resistivity measurements which are compatible with ASTM D257 Standard Test Methods for DC Resistance or Conductance of Insulating Materials. In the figure and tables shown below, the size and shape is compared for two pairs of electrodes: one that is specified in ASTM D257 and the one that is used with the 16008B Resistivity Cell. The similarity implies that the 16008B is compatible with ASTM D257.

### Note:

The main electrodes are orderable as a part by using following part numbers. Replace the main electrode when the conductive elastomer on the electrode comes off.

**26 mm electrode:** 16008-60083

**50 mm electrode:** 16008-60081

**76 mm electrode:** 16008-60085

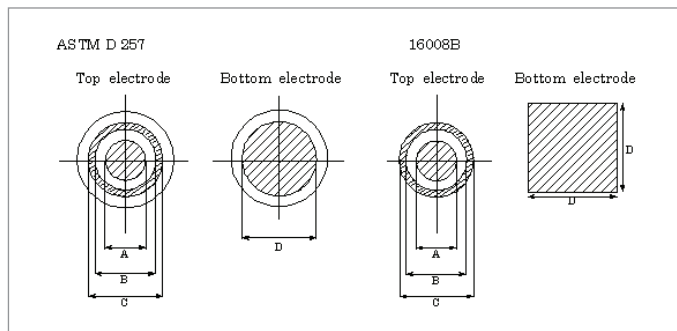

Compatibility with ASTM D257

### ASTM D257's recommended electrode sizes

	Choice 1	Choice 2
A	76 mm	25 mm
B	88 mm	38 mm
C	100 mm	50 mm
D	100 mm	50 mm

### 16008B electrode sizes

	Opt. 16008B-001	Opt. 16008B-001/002
A	76 mm	26 mm
B	88 mm	38 mm
C	98 mm	48 mm
D	110 mm	110 mm

## Other Accessories

### 16190B Performance Test Kit



**Terminal Connector:** 7 mm

**Dimensions (approx.):** 350(W) x 100(H) x 270(D) [mm]

**Weight (approx.):** 2.0 kg

**Description:** The 16190B is a performance test kit designed to verify the impedance measurement accuracy of LCR meters or impedance analyzers that have a 7 mm measurement terminal. Refer to the instrument's operation/service manual for the method of using these standards.

**Applicable Instrument:** E4991A, E4982A, 4287A\*, 4291B\*, 4294A + 42942A

\* denotes the instrument is obsolete.

#### Furnished Accessories:

Description	P/N	Qty.
Airline, 50 $\Omega$ , 7 mm	N/A	1
Cap, Protection	1401-0123	2
50 $\Omega$ Termination	N/A	1
Open Termination	N/A	1
Short Termination	N/A	1
Cap, Termination Protection	16190-25011	3
Wrench, 1/2 and 8/15, Open End	8710-1770	1
Carrying Case	N/A	1
Floppy Diskette for Calibration Data	N/A	1
Calibration Report	N/A	1
Operating Note	16190-90020	1



## Other Accessories

### 16380A Standard Capacitor Set



**Terminal Connector:** 4-Terminal Pair, BNC

**Dimensions (approx.):** 142(W) x 88(H) x 112(D) [mm] (capacitors)

**Weight (approx.):** 8.0 kg (including case and 4 capacitors)

**Description:** The 16380A is a standard capacitor set consisting of four precision capacitors -1 pF (16381A), 10 pF (16382A) 100 pF (16383A), 1000 pF (16384A). These capacitors are primarily used for performance tests of Keysight's 4-Terminal Pair LCR meters and impedance analyzers. Refer to the instrument's operation/service manual for the method of using these standards.

**Applicable Instrument:** 4263B, 4268A\*, 4279A\*, 4284A\*, 4285A, 4288A\*, 4294A, E4980A, E4981A

\* denotes the instrument is obsolete.

	16381A	16382A	16383A	16284A
Capacitance	1 pF	10 pF	100 pF	1000 pF
Nominal Accuracy	0.10 %			
Calibration Stability	≤ 300 ppm/year			
Dissipation Factor	≤ 0.0001			

#### Furnished Accessories:

Description	P/N	Qty.
16381A (1 pF)	N/A	1
16382A (10 pF)	N/A	1
16383A (100 pF)	N/A	1
16384A (1000 pF)	N/A	1
BNC (f) - (f) Adapters	1250-0080	4
Calibration Report	N/A	1
Carrying Case	16380-85101	1
Operating Note	16380-90011	1

## Other Accessories

### 16380C Standard Capacitor Set



**Terminal Connector:** 4-Terminal Pair, BNC

**Dimensions (approx.):** 142(W) x 88(H) x 112(D) [mm] (capacitors)

**Weight (approx.):** 7.0 kg (including case and 3 capacitors)

**Description:** The 16380C is a standard capacitor set consisting of three precision capacitors -0.01  $\mu\text{F}$  (16385A), 0.1  $\mu\text{F}$  (16386A), and 1  $\mu\text{F}$  (16387A). These capacitors are primarily used for performance tests of Keysight's 4-Terminal Pair LCR meters and impedance analyzers. Refer to the instrument's operation/service manual for the method of using these standards.

**Applicable Instrument:** 4263B, 4268A\*, 4284A\*, 4285A, 4288A\*, 4294A, E4980A, E4981A

\* denotes the instrument is obsolete.

	16381A	16382A	16383A	16284A
Capacitance	1 pF	10 pF	100 pF	1000 pF
Nominal Accuracy	0.10 %			
Calibration Stability	$\leq 300$ ppm/year			
Dissipation Factor	$\leq 0.0001$			

#### Furnished Accessories:

Description	P/N	Qty.
16385A (0.01 $\mu\text{F}$ )	N/A	1
16386A (0.1 $\mu\text{F}$ )	N/A	1
16387A (1 $\mu\text{F}$ )	N/A	1
BNC (f) - (f) Adapters	1250-0080	4
Calibration Report	N/A	1
Carrying Case	16380-85104	1
Operating Note	16380-90221	1

#### Option:

16380C-001: Add 10  $\mu\text{F}$  standard capacitor (16388A)

## Other Accessories

### 42030A Four-Terminal Pair Standard Resistor Set



**Terminal Connector:** 4-Terminal Pair, BNC

**Dimensions (approx.):** 94(W) x 31(H) x 67(D) [mm] (resistors)

**Weight (approx.):** 3.7 kg (including case and 9 resistors)

**Description:** The 42030A is a standard resistor set consisting of nine precision resistor standards which range from 1 mΩ to 100 kΩ. These resistors are primarily used for performance tests of Keysight's 4-Terminal Pair LCR meters and impedance analyzers. Refer to the instrument's operation/service manual for the method of using these standards.

**Applicable Instrument:** 4263B, 4268A\*, 4284A\*, 4294A, 4338B\*, E4980A, E4981A

\* denotes the instrument is obsolete.

Model	DC Resistance
42031A	1 mΩ ± 0.2%
42032A	10 mΩ ± 0.2%
42033A	100 mΩ ± 0.2%
42034A	1 Ω ± 0.2%
42035A	10 Ω ± 0.1%
42036A	100 Ω ± 0.1%
42037A	1 kΩ ± 0.1%
42038A	10 kΩ ± 0.1%
42039A	100 kΩ ± 0.1%

#### Furnished Accessories:

Description	P/N	Qty.
42031A (1 mΩ)	N/A	1
42032A (10 mΩ)	N/A	1
42033A (100 mΩ)	N/A	1
42034A (1 Ω)	N/A	1
42035A (10 Ω)	N/A	1
42036A (100 Ω)	N/A	1
42037A (1 kΩ)	N/A	1
42038A (10 kΩ)	N/A	1
42039A (100 kΩ)	N/A	1
Calibration Report	N/A	1
Carrying Case	42030-60100	1
Operating and Service Manual	42030-90001	1

## Other Accessories

### 42090A Open Termination



**Terminal Connector:** 4-Terminal Pair, BNC

**Dimensions (approx.):** 94(W) x 31(H) x 67(D) [mm]

**Weight (approx.):** 120 g

**Description:** The 42090A is an open termination and is primarily used for performance tests of Keysight's 4-Terminal Pair LCR meters and impedance analyzers. Refer to the instrument's operation/service manual for the method of using this standard.

**Applicable Instrument:** 4263B, 4268A\*, 4279A\*, 4284A\*, 4285A, 4288A\*, 4294A, E4980A, E4981A

\* denotes the instrument is obsolete.

### 42091A Short Termination



**Terminal Connector:** 4-Terminal Pair, BNC

**Dimensions (approx.):** 94(W) x 31(H) x 67(D) [mm]

**Weight (approx.):** 120 g

**Description:** The 42091A is a short termination and is primarily used for performance tests of Keysight's 4-Terminal Pair LCR meters and impedance analyzers. Refer to the instrument's operation/service manual for the method of using this standard.

**Applicable Instrument:** 4263B, 4268A\*, 4279A\*, 4284A\*, 4285A, 4294A, 4338B\*, E4980A, E4981A

\* denotes the instrument is obsolete.

## Appendix Additional Error

### The Concept of a Test Fixture's Additional Error

#### 1. System Configuration for Impedance Measurement

Frequently the system configured for impedance measurements uses the following components.

1. Impedance measurement instrument
2. Cables and adapter interfaces
3. Test fixture



System configuration for impedance measurement

The impedance measurement instrument's accuracy is defined at the measurement port of the instrument. This means that the accuracy at the measurement port is guaranteed and has calibration traceability.

In an actual measurement, there can be an extension of the measurement port with a cable or an adapter conversion to match the test fixture's terminal configuration. For this reason, cables and conversion adapters are provided for connectivity with the measurement port. These cables (and adapters) are designed to maintain high accuracy of the measurement instrument while extending the measurement port. Most of the time, the measurement accuracy of the instrument and the cable (or adapter) are specified together as a whole.

A test fixture is an accessory used to connect the DUT to the measurement instrument. Many test fixtures are provided to adapt to various shapes and sizes of DUTs. A test fixture is either connected directly to the measurement port of the instrument, or to the port of the extension cable or conversion adapter, as described earlier. The test fixture's structure determines the applicable frequency and impedance ranges. Hence, it is necessary to use the appropriate test fixture for the desired measurement conditions. In addition, each test fixture has its own inherent characteristic error, which is detailed in its operational manual.

#### 2. Measurement System Accuracy

The equation for the accuracy of a measurement system is:

$$(\text{Measurement accuracy}) = (\text{Instrument's accuracy}) + (\text{Test fixture's error})$$

The measurement instrument's accuracy is determined by an equation with terms that are dependent on frequency, measured impedance, signal level, and measurement time mode. By substituting the respective measurement conditions into the equation, the measurement accuracy is calculated. If a cable or a conversion adapter is used, then the specified measurement accuracy is the accuracy of the measurement instrument with the cable or adapter. This combined measurement accuracy is shown in the instrument's operational manual.

## Appendix Additional Error

The equation for the test fixture's additional error is shown below:

$$Z_e = \pm \{ A + (Z_s/Z_x + Y_o \cdot Z_x) \times 100 \} (\%)$$

$$D_e = Z_e/100 \quad (D \leq 0.1)$$

$Z_e$	: Additional Error for Impedance (%)
$D_e$	: Additional Error for Dissipation Factor
$A$	: Test Fixture's Proportional Error (%)
$Z_s/Z_x \times 100$	: Short Offset Error (%)
$Y_o \cdot Z_x \times 100$	: Open Offset Error (%)
$Z_s$	: Test Fixture's short Repeatability ( $\Omega$ )
$Y_o$	: Test Fixture's open Repeatability (S)
$Z_x$	: Measured Impedance Value of DUT( $\Omega$ )
$D$	: Measured D value

Proportional error, open and short repeatability are mentioned in the test fixture's operational manual and in this accessory guide. By inputting the measurement impedance and frequency (proportional error, open and short repeatability are usually a function of frequency) into the above equation, the fixture's additional error can be calculated.

### 2.1 Proportional Error:

The term, proportional error (A), was derived from the error factor, which causes the absolute impedance error to be proportional to the impedance being measured. If only the first term is taken out of the above equation and multiplied by  $Z_x$ , then  $\Delta Z = A \cdot Z_x$  ( $\Omega$ ). This means that the absolute value of the impedance error will always be A times the measured impedance. The largeness of proportional error is dependent upon how complicated the test fixture's construction is. Conceptually, it is dependent upon the stability of each element of the fixture's equivalent circuit model. From previous experience, proportional error is proportional to the frequency squared.

### 2.2 Short Offset Error:

The term,  $Z_s/Z_x \times 100$ , is called short offset error. If  $Z_x$  is multiplied to this term, then  $\Delta Z = Z_s$  ( $\Omega$ ). It can be concluded that this term affects the absolute impedance error, by adding an offset. Short repeatability ( $Z_s$ ) is determined from the variations in multiple measurements of the test fixture in short condition. After performing short compensation, the measured values of the short condition will distribute around 0 in the complex impedance plane. The maximum value of the impedance vector is defined as short repeatability. This is shown in the figure below. The larger short repeatability is the more difficult it is to measure small impedance values. For example, if the test fixture's short repeatability is 100 m $\Omega$ , then the additional error of an impedance measurement under 100 m $\Omega$  will be more than 100%. In essence, short repeatability is made up of a resistance and an inductance part, which become larger as the frequency becomes higher.

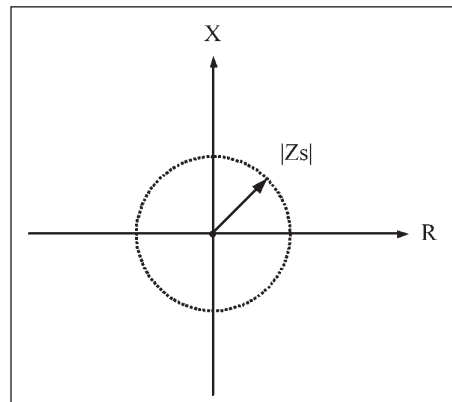

Definition of short repeatability

## Appendix Additional Error

### 2.3 Open Offset Error:

The term,  $Y_o \times Z_x \times 100$  is called open offset error. If  $Z_x$  is multiplied to this term, then  $\Delta Y = Y_o$ . This term affects the absolute admittance error, by adding an offset. Open repeatability,  $Y_o$ , is determined from the variations in multiple admittance measurements of the test fixture in open condition. After performing open compensation, the measured values of the open condition will distribute around 0 S in the complex admittance plane. As shown in the figure below, the maximum value of the admittance vector in the complex admittance plane is defined as open repeatability. The larger open repeatability is, the more difficult it is to measure large impedance values. Open repeatability is made up of a stray conductance and stray capacitance part, which become larger as the frequency becomes higher.

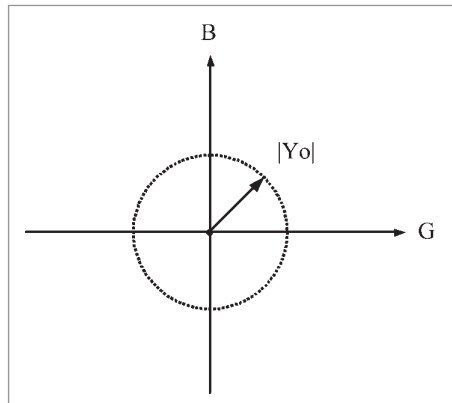

Definition of open repeatability

## 3. New Market Trends and the Additional Error for Test Fixtures

### 3.1 New Devices:

Recently, the debut of extremely low ESR capacitors, and the trend to use capacitors at much higher frequencies, have increased demand for low impedance measurements. As a result, the test fixture's short repeatability has become increasingly important. In the figure below, the relationship between proportional error, short offset error and frequency are shown when measuring low impedance of 100 m $\Omega$  and 10  $\Omega$ . Notice that when the measured impedance is less than 100 m $\Omega$ , short offset error influences the entirety of the test fixture's inherent error. As shown in the figure below, when the DUT's impedance is 100 m $\Omega$  and the test fixture's short repeatability is 10 m $\Omega$ , the short offset error will be 10 percent. Since the proportional error is minimal in low frequencies, the additional error will be 10 percent.

Until recently, to allow for additional error in test fixtures it was common to just specify the proportional error (A). As shown in the 10  $\Omega$  measurement case, if the measured impedance is large in comparison to the test fixture's short repeatability, then the short offset error can be ignored completely. This is the reason why open and short offset error was not previously specified. This is the reason for test fixtures that are only specified with proportional error. On the contrary, for measured impedance from 1  $\Omega$  to 10 k $\Omega$ , proportional error (A) alone is sufficient to express the test fixture's additional error.

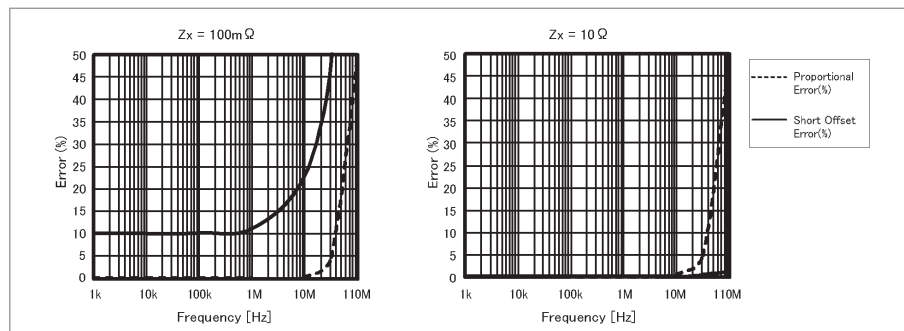

Relationship between proportional error, short offset error and frequency when measuring low impedance

## Appendix Additional Error

### 3.2 DUT Connection Configuration:

In order to make short repeatability small, there are test fixtures that use the 4T connection configuration (for example, Keysight 16044A). By employing this technique, the effect of contact resistance is reduced and short repeatability is significantly improved. As a result, the range of accurate low impedance measurements is expanded down to a low milliohm region.

Figure below shows the difference between the 2T connection and the 4T connection. In a 2T connection, the contact resistance that exists between the fixture's contact electrodes and the DUT, is measured together with the DUT's impedance. Contact resistance cannot be eliminated by compensation because the contact resistance value changes each time the DUT is contacted.

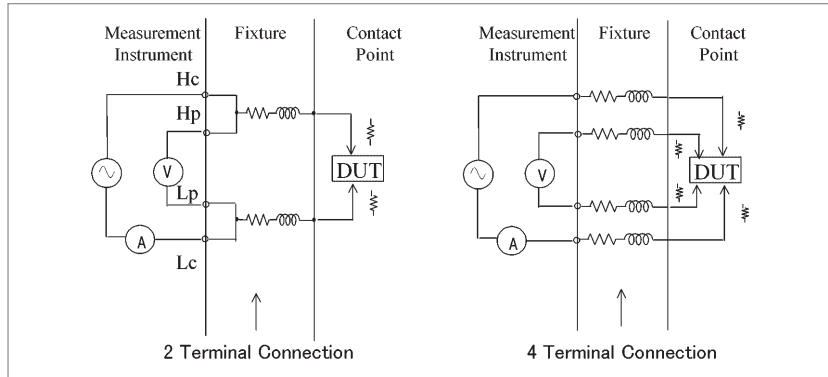

2-Terminal and 4-Terminal connector techniques

In a 4T connection, the voltage and current terminals are separate. Since the voltmeter has high input impedance, no current flows into the voltage terminals. Hence, the voltage that is applied across the DUT can be accurately detected without being affected by the contact resistance. Also, the current that flows through the DUT flows directly into the current terminal and is accurately detected without being affected by the contact resistance. As a result, the 4T connection method can eliminate the effect of contact resistance and realize a small short repeatability. By using a 4T test fixture, it is possible to measure low impedance with better accuracy than that which can be measured with a 2T test fixture.

The 2T test fixture can be used up to a higher frequency than the 4T test fixture. Since the 2T test fixture has a simple DUT connection configuration, the effects of residuals and mutual coupling ( $j\omega M$ ), which cause measurement error to increase with frequency, are smaller than those of the 4T test fixture and can be effectively reduced by compensation. Thus, the 2T connection is incorporated in test fixtures designed for use in the higher frequency region (typically up to 40 or 110 MHz).



### 3.3 Test Fixture's Adaptability for a Particular Measurement:

In order to make use of what has been discussed previously, the test fixture's adaptability for a particular measurement will be discussed. To see whether a test fixture is adaptable, it is important to think about the test fixture's additional error (proportional error, short repeatability, and open repeatability), measurement impedance, and the test frequency range.

If the measurement impedance is in the 1  $\Omega$  to 10 k $\Omega$  range, use only proportional error to calculate the additional error of the test fixture. It is fine to assume that this is a close approximation to the fixture's additional error.

If the measurement impedance is not in this range, use proportional error, short repeatability, and open repeatability to calculate the test fixture's additional error. Recent test fixtures have all three terms specified in their operational manual, so use these values for the calculation.

Some of the recent test fixtures (16044A), due to their structure, have different performance characteristics with different measurement instruments. For these test fixtures, refer to their operational manual for more details about the specifications.

If the test fixture is not specified with short and open repeatability, how can the test fixture's adaptability be determined? To measure a test fixture's short repeatability, measure the impedance of the short condition after performing short compensation. Take the shorting plate out of the fixture and then replace it. Measure the short condition again. By repeating this process at least 50 times, it will show the variations in the measured impedance of short condition (See figure below). The final step to determine an approximation of short repeatability is to add a margin to the values obtained. For open repeatability, measure the admittance of the test fixture's open condition. In the same way, determine open repeatability by measuring at least 50 times.

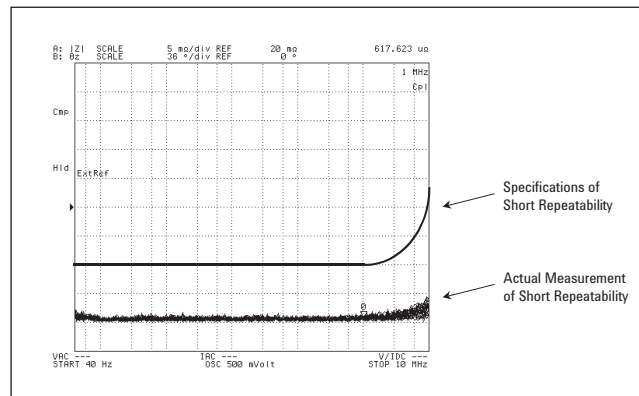

Measurement of short repeatability (16034G)

## Appendix Additional Error

### Measurement Settings

Measurement Instrument	: 4294A
Measurement Frequency	: 40 Hz-10 MHz
Measurement Parameter	: Z-θ
Compensation	: Performed short Compensation
Bandwidth	: 3
Measurement Method	: Inserted the shorting plate, measured the short condition, and then removed the shorting plate. Repeated this for 50 times.
Display Method	: Overlaying traces by using the Accumulate Mode

Lastly of all, a method to visually analyze the accurate measurement range of a test fixture is introduced. This method is only appropriate when all three error-terms (proportional error, open and short repeatability) are known. The table below shows the additional error of 16034G. The whole equation, with all three terms can be solved for measurement impedance rather than additional error, for example when additional error is equal to 0.5%. If the obtained impedance values are plotted with measurement impedance (y-axis) against frequency (x-axis), a graph similar to the one shown down below can be obtained. The shaded area shows the range of impedance that can be measured with an additional error better than 0.5%. In the same way, other graphs can be drawn with other additional error values to better visualize the accuracy that can be obtained for a given impedance and frequency range. The operational manuals of recent test fixtures present such graphs.

Additional Error of 16034G

Type of Error	Impedance
Proportional Error	$0.5 \times (f/10)^2$ [%]
Open Repeatability	$5 + 500 \times (f/10)$ [ $\mu$ S]
Short Repeatability	$10 + 13 \times (f/10)$ [m $\Omega$ ]

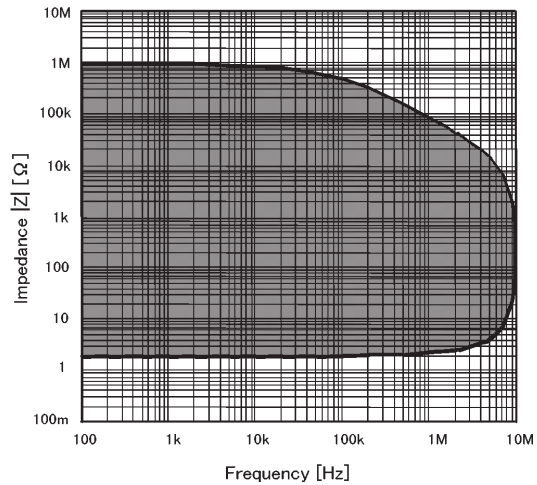

Range of impedance measurable with additional error  $\leq 0.5\%$

# Appendix Compensation

## Error Compensation

Keysight measurement instruments incorporate one of the following four types of error compensation functions to eliminate residual impedance effects in test fixtures:

### 1. Open/short Compensation

For a simple measurement system, represented by the equivalent circuit model shown below, residual impedance values  $R_s$  and  $L_s$  and admittance values  $C_o$  and  $G_o$  can be corrected by:

- (i) Measuring open condition for the test fixture's admittance.
- (ii) Measuring short condition for the test fixture's impedance
- (iii) Measuring the test sample, then subtracting the admittance and impedance.

The above procedure is performed internally by the open/short compensation. When the test fixture is directly connected to the measurement instrument, the open/short compensation sufficiently corrects the measurement error.

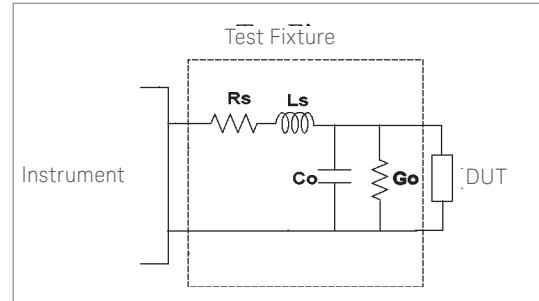

### 2. Open/short/load Compensation

When the measurement system is too complicated to be represented as the above equivalent circuit model, the open/short compensation cannot completely compensate for the residual impedance. In this case, the open/short/load compensation is used rather than the open/short compensation.

The open/short/load compensation is particularly effective when, for example, the 16065A is used with the measurement instrument.

The following table lists measurement instruments and available compensation functions.

Model	Open compensation	Short compensation	Load compensation	Load's input parameters
4263B	▪	▪	▪	Z-Q, R-X, Cp-D, Cp-Q, Cp-G, Cp-Rp, Cs-D, Cs-Q, Cs-Rs, Ls-D, Ls-Q, Ls-Rs
4268A*	▪	▪	▪	Cp-D, Cp-Q, Cp-G, Cp-Rp, Cs-D, Cs-Q, Cs-Rs
4279A*	▪	▪	▪	Cp-D, Cp-G
4284A*	▪	▪	▪	same as measurement parameters
4285A	▪	▪	▪	same as measurement parameters
4287A*	▪	▪	-	-
4288A*	▪	▪	▪	Cp-D, Cp-Q, Cp-G, Cp-Rp, Cs-Q, Cs-Rs
4291B*	▪	▪	▪	Rs-Ls
4294A	▪	▪	▪	Rs-Ls
4338B*	-	▪	-	-
4339B*	▪	-	-	-
4349B*	▪	-	-	-
E4980A	▪	▪	▪	same as measurement parameters
E4981A	▪	▪	▪	Cp-D, Cp-Q, Cp-G, Cp-Rp, Cs-D, Cs-Q, Cs-Rs
E4982A	▪	▪	-	-
E4991A	▪	▪	-	-

-: N/A

▪: Available

\*: denotes the instrument is obsolete.

**Note:** For more details of the compensation functions, refer to the instruction manuals supplied with the measurement instrument.

# Appendix Compensation

## 3. Electrical Length Compensation

In a single-port (Two-Terminal) impedance measurement at higher frequencies (RF region or higher), the wavelengths of the electrical signal are so short that the length of the signal transmission line including the test fixture and cables can cause an undesirable phase shift error. The phase shift error is corrected by the electrical length compensation, which should be performed in combination with the open/short compensation.

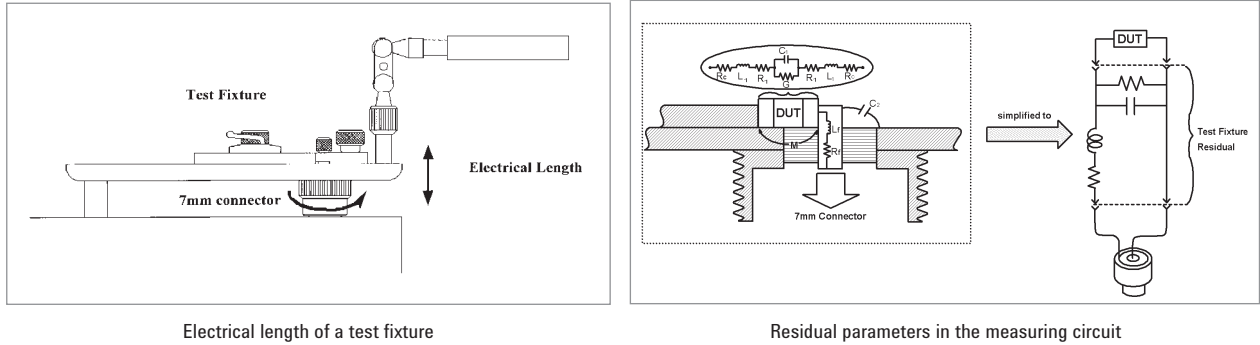

Electrical length of a test fixture

Residual parameters in the measuring circuit

The following measurement instruments are equipped with electrical length compensation function.

Model	Compensation Function
4287A*	Electrical Length Compensation/Port Extension
4291B*	Electrical Length Compensation/Port Extension
4294A + 42942A	Electrical Length Compensation/Port Extension
E5061B-3L5 + Option 005 + 16201A	Electrical Length Compensation/Port Extension
E4982A	Electrical Length Compensation/Port Extension
E4991A	Electrical Length Compensation/Port Extension

\* denotes the instrument is obsolete.

The electrical length is specified for the following test fixtures:

Model	Electrical Length
16092A	3.4 mm
16192A	11.0 mm
16194A	50.0 mm
16196A	26.2 mm
16196B	26.9 mm
16196C	27.1 mm
16196D	27.3 mm
16197A	14.0 mm

# Appendix Compensation

## 4. Cable Length Compensation

When the test sample is measured with an instrument having a Four-Terminal Pair configuration, the additional length of the test-lead extension between the instrument and the test sample, in conjunction with the measurement frequency, influences the amplitude and phase of the signal being measured. This must be taken into account, particularly for measurements performed at frequencies of 100 kHz or higher, since the modification of the amplitude and phase of the signal can cause the internal measurement circuit to malfunction or create an unexpected measurement error. Such circuit malfunctions and measurement errors can be avoided with cable length compensation. Cable length compensation should therefore be performed prior to the open/short compensation. When the following measurement instruments and test leads are used in combination, the undesired effects described above can be eliminated by performing the cable length compensation (the values in the table represent cable length settings):

Model	16048A	16048D	16048E	16048G	16048H
4263B	1 m	2 m	4 m	-	-
4268A*	1 m	2 m	-	-	-
4279A*	1 m	2 m	-	-	-
4284A*	1 m	2 m <sup>1</sup>	4 m <sup>1</sup>	-	-
4285A	1 m	2 m	-	-	-
4288A*	1 m	2 m	-	-	-
4294A	-	-	-	1 m	2 m
E4980A	1 m	2 m	4 m	-	-
E4981A	1 m	2 m	-	-	-

–: N/A

<sup>1</sup>: Available for 4284A with Option 006.

\*: denotes the instrument is obsolete

### Measurement Repeatability

Dirty electrodes on the test fixture cause an increase in the contact resistance. This increase in resistance can cause poor measurement repeatability. Therefore, the electrode of the test fixture must be kept clean when measurements are performed.

# Index

Model Number	Name	Applicable Measurement Instrument (s)	Page (s)
16008B	Resistivity Cell	4339B	58-59
16034E	SMD/Chip Test Fixture	4263B, 4268A, 4279A, 4284A, 4285A, 4288A, 4294A, E4980A, E4981A E5061B-3L5 (w/Option 005)	12
16034G	SMD/Chip Test Fixture, Small	refer to 16034E	13
16034H	SMD/Chip Test Fixture, General	refer to 16034E	14
16044A	SMD/Chip Test Fixture, Four-Terminal, 10 MHz	4263B, 4268A, 4279A, 4284A, 4285A, 4288A, 4294A, E4980A, E4981A	15-16
16047A	Axial and Radial Test Fixture	4263B, 4268A, 4279A, 4284A, 4285A, 4288A, 4294A, E4980A, E4981A	9
16047E	Axial and Radial Test Fixture, 110 MHz	refer to 16034E	10
16048A	One Meter Test Leads, BNC	4263B, 4268A, 4279A, 4284A, 4285A, 4288A, E4980A, E4981A	20
16048D	Two Meter Test Leads, BNC	4263B, 4268A, 4279A, 4284A, 4285A, 4288A, E4980A, E4981A	20
16048E	Four Meter Test Leads, BNC	4263B, 4284A, E4980A	21
16048G	One Meter Test Leads, BNC, 110 MHz	4294A	22
16048H	Two Meter Test Leads, BNC, 110 MHz	4294A	22
16060A	Transformer Test Fixture	4263B w/Option 001	11
16065A	Ext. Voltage Bias with Safety Cover ( $\leq 200$ vdc)	4263B, 4268A, 4279A, 4284A, 4285A, 4288A, 4294A, E4980A, E4981A	24
16065C	External Bias Adapter ( $\leq 40$ vdc)	4263B, 4268A, 4288A, E4981A	24
16089A/B/C/D	Kelvin Clip Leads	4263B, 4268A, 4279A, 4284A, 4285A, 4288A, 4294A, E4980A, E4981A	18-19
16092A	RF Spring Clip : Axial, Radial and SMD	4287A, 4291B, 4294A + 42942A, E5061B-3L5 (w/Option 005) + 16201A, E4982A, E4991A	32
16117B	Low Noise Test Leads	4339B	56
16117C	Low Noise Test Leads	4339B	57
16118A	SMD/Chip Tweezers	4339B	55
16190B	Performance Test Kit	E4991A, 4291B, 4294A + 42942A, 4287A, E4982A	60
16192A	Parallel Electrode SMD Test Fixture	4287A, 4291B, 4294A + 42942A, E5061B-3L5 (w/Option 005) + 16201A, E4982A, E4991A	33-34
16194A	High Temperature Component Test Fixture	refer to 16192A	35-36
16196A/B/C/D	Parallel Electrode SMD Test Fixture	refer to 16192A	37-45
16197A	Bottom Electrode SMD Test Fixture	refer to 16192A	46-48
16200B	External DC Bias Adapter	4287A, 4291B, E5061B-3L5 (w/Option 005) + 16201A, E4982A, E4991A	49
16334A	SMD/Chip Tweezers	4263B, 4268A, 4279A, 4284A, 4285A, 4288A, 4294A, E4980A, E4981A	17
16339A	Component Test Fixture for 4339A/B	4339B	54
16380A	C Standards Set	4263B, 4268A, 4279A, 4284A, 4285A, 4288A, 4294A, E4980A, E4981A	61
16380C	C Standards Set	4263B, 4268A, 4284A, 4288A, 4294A, E4980A, E4981A	62
16451B	Dielectric Material Test Fixture	4263B, 4268A, 4279A, 4284A, 4285A, 4288A, 4294A, E4980A, E4981A	25-28
16452A	Liquid Test Fixture	4263B, 4284A, 4285A, 4294A, E4980A	29-30
16453A	Dielectric Material Test Fixture	4291B (w/Option 002), E4991A (w/Option 002)	50
16454A	Magnetic Material Test Fixture	4291B (w/Option 002), 4294A + 42942A, E4991A (w/Option 002)	51-52
42030A	Four-Terminal Pair Standard Resistor Set	4263B, 4268A, 4284A, 4294A, 4338B, E4980A, E4981A	63
42090A	Open Termination	4263B, 4268A, 4279A, 4284A, 4285A, 4294A, 4288A, E4980A, E4981A	64
42091A	Short Termination	4263B, 4268A, 4279A, 4284A, 4285A, 4294A, 4338B, E4980A, E4981A	64
42941A	Impedance Probe Kit	4294A	23
42942A	Four-Terminal Pair to 7 mm	4294A	5

# Index

## Test Fixture Selection By SMD Size

Classification	Test fixture type	Model number	Electrode type	Maximum usable frequency	● Applicable SMD size [code in mm / (EIA code in inch)] <sup>7</sup>											Minimum L x W x H (mm)	Maximum L x W x H (mm)
					0402 / (01005)	0603 / (0201)	1005 / (0402)	1608 / (0603)	2012 / (0805)	3216 / (1206)	3225 / (1210)	4520 / (1808)	4532 / (1812)	5750 / (2220)			
LF, 4TP <sup>*1</sup>	SMD, General	16034E	Parallel	40 MHz				●	●	●	●	●	●	●	0.1 x 0.5 x 0.5	8 x 10 x 10	
	SMD, General	16034G	Parallel	110 MHz		●	●	●	●	●					0.1 x 0.3 x 0.3	5 x 1.6 x 1.6	
	SMD, General	16034H	Parallel	110 MHz				●	●	●	●	●	●		0.1 x 0.6 x 0.6	5 x 15 x 3	
	SMD, Kelvin <sup>*4</sup>	16044A	Parallel	10 MHz				●	●	●	●	●	●	●	1.6 x 0.8 x 0.8	8 x 8 x 3	
	SMD, Tweezers <sup>*5</sup>	16334A	Parallel	15 MHz				●	●	●	●	●	●	●	See Note 9	L ≤ 10	
RF, 7 mm <sup>*2</sup>	SMD / Lead <sup>*6</sup>	16092A	Parallel	500 MHz				●	●	●	●	●	●	●	See Note 8	L ≤ 18	
	SMD, General	16192A	Parallel	2 GHz			●	●	●	●	●	●	●	●	L ≥ 1	L ≤ 20	
	SMD / Lead <sup>*6</sup>	16194A	Bottom	2 GHz					●	●	●	●	●	●	L ≥ 2	L ≤ 15	
	SMD, Coaxial	16196A	Parallel	3 GHz				●							1608 size only		
	SMD, Coaxial	16196B	Parallel	3 GHz			●								1005 size only		
	SMD, Coaxial	16196C	Parallel	3 GHz		●									0603 size only		
	SMD, Coaxial	16196D	Parallel	3 GHz	●										0402 size only		
	SMD, General	16197A	Bottom	3 GHz			●	●	●	●	●				1005 to 3225 sizes only		
DC, high R <sup>*3</sup>	SMD, Tweezers <sup>*5</sup>	16118A	Parallel	DC				●	●	●	●	●	●	●	See Note 9	L ≤ 10	
	SMD / Lead <sup>*8</sup>	16339A	Parallel	DC			●	●	●	●	●	●	●	●	0.1 x 0.5 x 0.5	8 x 10 x 10	

### Notes:

1. LF, 4TP denotes test fixtures for use with four-terminal pair type LCR meters and LF impedance analyzers in low frequency region (≤ 110 MHz).
2. RF, 7 mm denotes test fixtures for use with RF impedance measurement instruments which have 7 mm coaxial test port.
3. DC, high R denotes test fixtures for use with DC high resistance meter.
4. Four-terminal (Kelvin) contact test fixture suitable for measuring low impedance devices.
5. Tweezers type test fixture with 1 meter test leads.
6. Test fixture for measuring SMD and leaded components.
7. Check marks in the table denote the applicable DUT sizes.
8. Applicable to SMD components with thickness ≥ 0.65 mm. Not suitable for smaller SMD than 1608 type.
9. Minimum SMD size is not specified. Not recommended for smaller SMD than 1608 type because contact repeatability degrades with the reduction of device size.

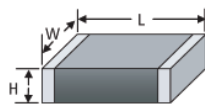

Parallel electrode

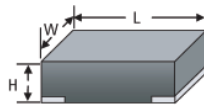

Bottom electrode

## Accessories vs. Instruments Matrix

### Simplify and Improve Your Measurements with Keysight's Test Accessories

Selecting a test fixture is as important as selecting the right instrument. Keysight offers a wide range of accessories for axial, radial, and SMD/Chip devices. In addition, a variety of test leads are available to simplify remote testing and systems applications. External test fixtures with safety covers are also available.

You will improve your measurement results with the proper test fixture.

- more reliable and repeatable measurement
- higher through put
- fewer handling errors
- tighter test limits
- better measurement accuracy

For additional product information and literature, visit our Accessories Web site: [www.keysight.com/find/impedance](http://www.keysight.com/find/impedance)

Test accessories/fixtures			4263B	4268A	4279A	4284A	4285A	4287A	4288A	4294A	4294A with 42942A	E5061B-3L5 w/Option E5061B-005 and 16201A	E4980A	E4981A	E4991A	E4982A
16034E	SMD/chip test fixture	DC-40 MHz	•	•	•	•	•	•	•	•				•	•	
16034G	SMD/chip test fixture, small	DC-110 MHz	•	•	•	•	•	•	•	•				•	•	
16034H	SMD/chip test fixture, general	DC-110 MHz	•	•	•	•	•	•	•	•				•	•	
16044A	SMD/chip test fixture, Kelvin contacts, 10 MHz	DC-10 MHz	•	•	•	•	•	•	•	•				•	•	
16047A	Axial and radial test fixture (4-terminal)	DC-13 MHz	•	•	•	•	•	•	•	•				•	•	
16047E	Axial and radial test fixture, 110MHz	DC-110 MHz	•	•	•	•	•	•	•	•				•	•	
16048A	One meter test leads, BNC	DC-30 MHz	•	•	•	•	•	•	•	•				•	•	
16048D	Two meter test leads, BNC	DC-30 MHz	•	•	•	•	•	•	•	•				•	•	
16048E	Four meter test leads, BNC	DC-1 MHz	•		•									•		
16048G	One meter test leads, BNC, 110 MHz	DC-110 MHz								•						
16048H	Two meter test leads, BNC, 110 MHz	DC-110 MHz								•						
16060A	Transformer test fixture	DC-100 kHz	•													
16065A	Ext. voltage bias with safety cover (<=200 vdc)	50 Hz-2 MHz	•	•	•	•	•	•	•	•				•	•	
16065C	External bias adapter (<=40 vdc)	100 Hz-1 MHz	•	•					•							•
16089A/B/C/D	Kelvin clip leads	5 Hz-100 kHz	•	•	•	•			•	•				•	•	
16092A	RF spring clip: axial, radial and SMD	DC-500 MHz						• <sup>1</sup>			•	•			•	• <sup>1</sup>
16192A	Parallel electrode SMD test fixture	DC-2 GHz						• <sup>1</sup>			•	•			•	• <sup>1</sup>
16194A	High temperature component test fixture	DC-2 GHz						• <sup>1</sup>			•	•			•	• <sup>1</sup>
16196A/B/C/D	Parallel electrode SMD test fixture	DC-3 GHz						• <sup>1</sup>			•	•			•	• <sup>1</sup>
16197A	Bottom electrode SMD test fixture	DC-3 GHz						• <sup>1</sup>			•	•			•	• <sup>1</sup>
16200B	External DC bias adapter	1 MHz-1 GHz						• <sup>1</sup>			•	•			•	• <sup>1</sup>
16334A	SMD/chip tweezers	5Hz-15 MHz	•	•	•	•	•	•	•	•				•	•	
16451B	Dielectric material test fixture	DC-30 MHz	•	•	•	•	•	•	•	•				•	•	
16452A	Liquid test fixture	20-30 MHz			•	•				•				•		
16453A	Dielectric material test fixture	1 MHz-1 GHz														•
16454A	Magnetic material test fixture	1 kHz-1 GHz									•					•
42941A	Impedance probe kit	40Hz-110 MHz								•						
42942A	Four-terminal pair to 7-mm adapter	40Hz-110 MHz								•						

**Note:** Refer to the accessory descriptions for frequency and operational limits.  
1. 3.5-mm (M) to 7-mm adapter is required



## Keysight Web Resources

LCR Meters/**Impedance Analyzers**:

[www.keysight.com/find/impedance](http://www.keysight.com/find/impedance)

Accessories for Impedance Measurements:

[www.keysight.com/find/impedance-accessory](http://www.keysight.com/find/impedance-accessory)

RF and microwave test accessories:

[www.keysight.com/find/accessories](http://www.keysight.com/find/accessories)

**myKeysight**

**myKeysight**

[www.keysight.com/find/mykeysight](http://www.keysight.com/find/mykeysight)

A personalized view into the information most relevant to you.



[www.axistandard.org](http://www.axistandard.org)

AdvancedTCA® Extensions for Instrumentation and Test (AXIe) is an open standard that extends the AdvancedTCA for general purpose and semiconductor test. Keysight is a founding member of the AXIe consortium. ATCA®, AdvancedTCA®, and the ATCA logo are registered US trademarks of the PCI Industrial Computer Manufacturers Group.



[www.lxistandard.org](http://www.lxistandard.org)

LAN eXtensions for Instruments puts the power of Ethernet and the Web inside your test systems. Keysight is a founding member of the LXI consortium.

**Three-Year Warranty**

[www.keysight.com/find/ThreeYearWarranty](http://www.keysight.com/find/ThreeYearWarranty)

Keysight's commitment to superior product quality and lower total cost of ownership. The only test and measurement company with three-year warranty standard on all instruments, worldwide.



**Keysight Assurance Plans**

[www.keysight.com/find/AssurancePlans](http://www.keysight.com/find/AssurancePlans)

Up to five years of protection and no budgetary surprises to ensure your instruments are operating to specification so you can rely on accurate measurements.



[www.keysight.com/quality](http://www.keysight.com/quality)

Keysight Technologies, Inc.  
DEKRA Certified ISO 9001:2008  
Quality Management System



**Keysight Channel Partners**

[www.keysight.com/find/channelpartners](http://www.keysight.com/find/channelpartners)

Get the best of both worlds: Keysight's measurement expertise and product breadth, combined with channel partner convenience.

[www.keysight.com](http://www.keysight.com)

For more information on Keysight Technologies' products, applications or services, please contact your local Keysight office. The complete list is available at: [www.keysight.com/find/contactus](http://www.keysight.com/find/contactus)

**Americas**

Canada	(877) 894 4414
Brazil	55 11 3351 7010
Mexico	001 800 254 2440
United States	(800) 829 4444

**Asia Pacific**

Australia	1 800 629 485
China	800 810 0189
Hong Kong	800 938 693
India	1 800 112 929
Japan	0120 (421) 345
Korea	080 769 0800
Malaysia	1 800 888 848
Singapore	1 800 375 8100
Taiwan	0800 047 866
Other AP Countries	(65) 6375 8100

**Europe & Middle East**

Austria	0800 001122
Belgium	0800 58580
Finland	0800 523252
France	0805 980333
Germany	0800 6270999
Ireland	1800 832700
Israel	1 809 343051
Italy	800 599100
Luxembourg	+32 800 58580
Netherlands	0800 0233200
Russia	8800 5009286
Spain	0800 000154
Sweden	0200 882255
Switzerland	0800 805353
	Opt. 1 (DE)
	Opt. 2 (FR)
	Opt. 3 (IT)
United Kingdom	0800 0260637

For other unlisted countries:  
[www.keysight.com/find/contactus](http://www.keysight.com/find/contactus)  
(BP-07-10-14)

