

Operating and
Service Manual

Keysight Technologies
85059B
1.0 mm Precision
Calibration Kit

Notices

© Keysight Technologies, Inc.
2016-2021

No part of this manual may be reproduced in any form or by any means (including electronic storage and retrieval or translation into a foreign language) without prior agreement and written consent from Keysight Technologies, Inc. as governed by United States and international copyright laws.

Trademark Acknowledgments

Manual Part Number

85059-90005

Edition

Edition 1, March 2021

Printed in USA/Malaysia

Published by:
Keysight Technologies
1400 Fountaingrove Parkway
Santa Rosa, CA 95403

Warranty

THE MATERIAL CONTAINED IN THIS DOCUMENT IS PROVIDED "AS IS," AND IS SUBJECT TO BEING CHANGED, WITHOUT NOTICE, IN FUTURE EDITIONS. FURTHER, TO THE MAXIMUM EXTENT PERMITTED BY APPLICABLE LAW, KEYSIGHT DISCLAIMS ALL WARRANTIES, EITHER EXPRESS OR IMPLIED WITH REGARD TO THIS MANUAL AND ANY INFORMATION CONTAINED HEREIN, INCLUDING BUT NOT LIMITED TO THE IMPLIED WARRANTIES OF MERCHANTABILITY AND FITNESS FOR A PARTICULAR PURPOSE. KEYSIGHT SHALL NOT BE LIABLE FOR ERRORS OR FOR INCIDENTAL OR CONSEQUENTIAL DAMAGES IN CONNECTION WITH THE FURNISHING, USE, OR PERFORMANCE OF THIS DOCUMENT OR ANY INFORMATION CONTAINED HEREIN. SHOULD KEYSIGHT AND THE USER HAVE A SEPARATE WRITTEN AGREEMENT WITH WARRANTY TERMS COVERING THE MATERIAL IN THIS

DOCUMENT THAT CONFLICT WITH THESE TERMS, THE WARRANTY TERMS IN THE SEPARATE AGREEMENT WILL CONTROL.

Technology Licenses

The hardware and/or software described in this document are furnished under a license and may be used or copied only in accordance with the terms of such license.

U.S. Government Rights

The Software is "commercial computer software," as defined by Federal Acquisition Regulation ("FAR") 2.101. Pursuant to FAR 12.212 and 27.405-3 and Department of Defense FAR Supplement ("DFARS") 227.7202, the U.S. government acquires commercial computer software under the same terms by which the software is customarily provided to the public.

Accordingly, Keysight provides the Software to U.S. government customers under its standard commercial license, which is embodied in its End User License Agreement (EULA), a copy of which can be found at

<http://www.keysight.com/find/sweula>

The license set forth in the EULA represents the exclusive authority by which the U.S. government may use, modify, distribute, or disclose the Software. The EULA and the license set forth therein, does not require or permit, among other things, that Keysight: (1) Furnish technical information related to commercial computer software or commercial computer software documentation that is not customarily provided to the public; or (2) Relinquish to, or otherwise provide, the government rights in excess of these rights customarily provided to the public to use, modify, reproduce, release, perform, display, or disclose commercial computer software or commercial computer software documentation. No additional

government requirements beyond those set forth in the EULA shall apply, except to the extent that those terms, rights, or licenses are explicitly required from all providers of commercial computer software pursuant to the FAR and the DFARS and are set forth specifically in writing elsewhere in the EULA. Keysight shall be under no obligation to update, revise or otherwise modify the Software. With respect to any technical data as defined by FAR 2.101, pursuant to FAR 12.211 and 27.404.2 and DFARS 227.7102, the U.S. government acquires no greater than Limited Rights as defined in FAR 27.401 or DFARS 227.7103-5 (c), as applicable in any technical data.

Safety Notices

CAUTION

A **CAUTION** notice denotes a hazard. It calls attention to an operating procedure, practice, or the like that, if not correctly performed or adhered to, could result in damage to the product or loss of important data. Do not proceed beyond a CAUTION notice until the indicated conditions are fully understood and met.

WARNING

A **WARNING** notice denotes a hazard. It calls attention to an operating procedure, practice, or the like that, if not correctly performed or adhered to, could result in personal injury or death. Do not proceed beyond a WARNING notice until the indicated conditions are fully understood and met.

1. General Information

Chapter One at-a-Glance	1-1
About this Manual	1-1
Chapter One at-a-Glance	1-1
Calibration Kit Overview	1-3
Kit Contents	1-3
Compatible Network Analyzers	1-3
Data-Based Model for Defining the Calibration Standards	1-3
Data-Based Model	1-4
85059B (Precision) Kit Contents	1-4
The 85059B (Precision) calibration kit contains the following:	1-4
Offset Opens and Shorts	1-5
How to Identify Devices	1-5
Adapters	1-5
Lowband Loads	1-6
Performing a Calibration	1-6
Using a Network Analyzer	1-6
Calibration Definitions	1-6
Equipment Required but Not Supplied	1-6
Offset-Short Calibration Using the 85059B (Precision) Calibration Kit and the PNA's Guided Power Calibration	1-7
Calibration Residual Error Specifications.	1-8
Serial Numbers	1-9
Serial Number Prefix.	1-9
Serial Number Suffix	1-9
Device Serial Numbers.	1-9
Recording the Device Serial Numbers.	1-10
Incoming Inspection	1-10
Clarifying Connector Gender	1-12
Clarifying the Terminology of a Connector Interface.	1-13
Preventive Maintenance	1-13
When to Calibrate.	1-14
Regulatory and Environmental Information.	1-15

2. Specifications

Information in This Chapter	2-1
Chapter Two at-a-Glance.	2-1
Environmental Requirements	2-2
Temperature—What to Watch Out For.	2-2

Contents

Mechanical Characteristics	2-3
Electrical Specifications.	2-4
Certification	2-6
3. Use, Maintenance, and Care of the Devices	
Information in this Chapter	3-1
Chapter Three at-a-Glance	3-1
Electrostatic Discharge	3-2
Visual Inspection	3-4
Look for Obvious Defects and Damage First	3-4
What Causes Connector Wear?	3-5
Connector Contacts	3-5
Concentricity	3-5
Inspect the Mating Plane Surfaces	3-6
Inspect Female Connectors.	3-7
Supplies and Equipment Needed	3-7
Cleaning Connectors	3-8
Pin Depth	3-10
Making Connections	3-12
How to Make a Connection.	3-12
Connection Procedure.	3-12
Connector Misalignment.	3-13
How to Separate a Connection.	3-13
Using a Torque Wrench	3-15
Disconnection Procedure.	3-19
Handling and Storage	3-19
4. Performance Verification	
Information in This Chapter	4-1
Chapter Four at-a-Glance.	4-1
Introduction	4-1
How Keysight Verifies the Devices in This Kit	4-2
Recertification	4-2
How Often to Recertify	4-3
Where to Send a Kit for Recertification.	4-3
5. Troubleshooting	
Information in This Chapter	5-1
Chapter Five at-a-Glance	5-1
Troubleshooting Process	5-2

Where to Look for More Information	5-3
Returning a Kit or Device to Keysight	5-3
Contacting Keysight	5-4
Printing Copies of Documentation from the Web	5-4
6. Replacement Parts	
Information in This Chapter	6-1
Chapter Six at-a-Glance	6-1
Introduction	6-1
7. Standard Definitions	
Information in This Chapter	7-1
Chapter Seven at-a-Glance	7-1
Class Assignments and Standard Definitions Values are Available on the Web.	7-1

Contents

1 General Information

Chapter One at-a-Glance

About this Manual

This manual describes the 85059B calibration kit and provides replacement part numbers, specifications, and procedures for using, maintaining and troubleshooting this kit.

Chapter One at-a-Glance

Section Title	Summary of Content
“Calibration Kit Overview” on page 1-3	Describes the 85059B calibration kit contents, how to identify shorts, and compatible network analyzers.
“Offset-Short Calibration Using the 85059B (Precision) Calibration Kit and the PNA’s Guided Power Calibration” on page 1-7	Provides links for performing a Guided Power Calibration and using the 85059B calibration kit.
“Calibration Residual Error Specifications” on page 1-8	Describes the data-based residual error specifications. Refer to Table 1-1 on page 1-8 .
“Serial Numbers” on page 1-9	How to verify your calibration kit’s serial number in a table to avoid possible confusion with other calibration kits.
“Incoming Inspection” on page 1-10	Verifying your calibration kit’s contents and what to do, if there is an problem.
“Clarifying Connector Gender” on page 1-12	A discussion of how to identify the male and female connectors.
“Clarifying the Terminology of a Connector Interface” on page 1-13	A discussion of some of the connector terminology.
“Preventive Maintenance” on page 1-13	How to avoid damaging the devices in your calibration kit.
“When to Calibrate” on page 1-14	How often should you re-calibrate your network analyzer.

Section Title	Summary of Content
“Regulatory and Environmental Information” on page 1-15	Description of regulatory symbols.

Calibration Kit Overview

The 85059B 1.0 mm precision calibration kit is used to calibrate your PNA series network analyzer system. This kit is used for the measurement of components with 50 Ω , 1.0 mm connectors with a frequency range of DC to 120 GHz.

Because it is physically impossible to construct a slotless version of the 1.0 mm female contact, the female devices in this kit use slotted contacts. The slotted female contact does not have the same electrical characteristics as a solid conductor, and therefore, the male and female devices in this kit have different models.

Although the male and female devices are designed to have the same mechanical length, their electrical delays are different. This reflects the differences in the connector interface compression. When the male and female devices are torqued together the male side compresses more than the female side.

The 1.0 mm connector utilizes an air dielectric interface for the highest accuracy and repeatability. The coupling diameter and thread size were chosen to maximize strength, increase durability and provide highly repeatable connections. The connectors are designed so that the outer conductors engage before the center conductors.

To obtain the best performance possible, the manufacturing tolerances of the connectors are tighter than the standard 1.0 mm specifications per the IEEE 287 precision connector standard.

Kit Contents

Use the Contents List in the shipping container to verify the completeness of your shipment. Although this list is the most accurate, you can also use the illustration in **Table 6-1 on page 6-2** to verify the items in your shipment. If your shipment is not complete, contact Keysight Technologies - refer to **“Contacting Keysight” on page 5-4**.

Compatible Network Analyzers

The devices in this kit and their data are compatible with the PNA series network analyzers.

Data-Based Model for Defining the Calibration Standards

The 85059 family of calibration kits uses the Data-Based models to define the calibration standards.

Data-Based Model

The data-based model (85059B) of each calibration kit provides higher accuracy for describing calibration standards than a polynomial model. The data-based nominal S-Parameter model for each calibration standard is generated by using a theoretical derivation or a high accuracy S-Parameter measurement. These nominal S-parameter models are stored as part of the data-based model. Errors that can be the result of polynomial model approximations do not exist.

The data-based models may only be used with the SmartCal (Guided) Calibration method of the Cal Wizard. Using the data-based models with the Unguided Calibration method of the Cal Wizard is not allowed.

The data-based models may NOT be edited with the Advanced Modify Cal Kit dialog box. Attempts to programmatically edit the definitions of the data-based-model calibration standards will result in reported errors (i.e. SCPI Execution Error).

In the PNA's Modify Calibration Class Assignments dialog box¹, the "Expanded Math" feature is turned ON by default when the 85059B data-based model is selected from a cal kit menu. In order to achieve a more accurate calibration, Expanded Math uses the data at any given frequency from ALL measured standards instead of using only the three standards specified in the class definitions.

85059B (Precision) Kit Contents

The 85059B (Precision) calibration kit contains the following:

- one pair (male and female) of an offset open
- one pair (male and female) of a lowband load
- four pairs (male and female) of offset shorts
- three adapters
- form-tracking recalibration date due
- calibration certificate
- wrench, open end for the 6 mm flats on some of the components
- wrench-torque, 4-in-lb. 6 mm open end, gold handle
- wrench-torque, 4-in-lb. 14 mm open end, gold handle
- a 10x magnifying glass
- case—plastic storage

1. Pathway to the Modify Calibration Class Assignments dialog box: Calibration > Advanced Modify Cal Kit > Edit Kit > Class Assignments: Edit.

Refer to [Table 6-1 on page 6-2](#) and [Figure 6-1 on page 6-3](#) for a complete list of kit contents and their associated part numbers.

Offset Opens and Shorts

The offset opens and shorts are built from parts that are machined to the current state-of-the-art in precision machining. The offset short's inner conductors have a one-piece construction, common with the shorting plane. This construction provides for extremely repeatable connections. The offset opens have inner conductors that are supported by a strong, low dielectric plastic to provide repeatability and reliability. Both the opens and shorts are constructed so that the pin depth can be controlled very tightly, thereby minimizing phase errors. The length of the offset opens are designed so that the difference in phase of their reflection coefficients is approximately 180° at all frequencies, with respect to offset short 2.

How to Identify Devices

The shorts, opens, and loads in the kit are identified by the number of rings (or bands) around the body of the device.

- lowband loads have no rings or bands
- 1.3 mm offset short has 1 ring or band and is identified as Short 1
- 2.45 mm offset short has 2 rings or bands and is identified as Short 2
- 3.326 mm offset short has 3 rings or bands and is identified as Short 3
- 4.039 mm offset short has 4 rings or bands and is identified as Short 4
- offset open has 3 rings and is designed to be 180 degrees out of phase with Short 2. In addition, the offset open has a rounded edge to help distinguish it from the shorts (see [Figure 1-1](#)).

Figure 1-1

OPEN Calibration Devices: 85059B

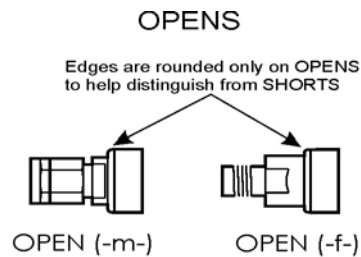

Adapters

Like the other devices in the kit, the adapters are built to very tight tolerances to provide good broadband performance and to ensure stable, repeatable connections.

Lowband Loads

The loads have been optimized for broadband performance up to 50 GHz.

NOTE

The best operating region of the load is from DC to 50 GHz. Performance degrades quickly above 50 GHz.

Performing a Calibration

Using a Network Analyzer

To find information about performing a calibration with your network analyzer, refer to your analyzer's User's Guide or Help system. To find an online copy on the Keysight web site:

1. Go to www.keysight.com
2. Enter the analyzer's model in the search box.
3. Press **Enter**
4. On the web page that opens, underneath the title of your Network Analyzer, click **Support**
5. Click the **Documentation Library** icon
6. Click the link for the document you want to view

Calibration Definitions

The calibration kit must be selected prior to performing a calibration. In addition, the calibration definitions for the devices in the kit must be installed in the analyzer as part of a firmware upgrade (≥ 12.80). Refer to <http://na.support.keysight.com/pna/>.

Class assignments and standard definitions may change as more accurate model and calibration methods are developed. For reference, you can download and view the most recent class assignments and standard definitions from Keysight's Calibration Kit Definitions Web page at <http://na.support.keysight.com/pna/caldefs/stddefs.html>.

Refer to online PNA Help for instructions on selecting the calibration kit, installing (if necessary) the calibration definitions, and performing a calibration.

Equipment Required but Not Supplied

Various connector cleaning supplies and electrostatic discharge safety supplies are not provided in this kit. (Refer to **Chapter 6, "Replacement Parts", on page 6- 1** for ordering information.)

General Information

Offset-Short Calibration Using the 85059B (Precision) Calibration Kit and the PNA's Guided Power Calibration

Gage sets (not provided with the 85059B), adapters, ESD protection devices, and various connector cleaning supplies are not included in the calibration kit but are required to ensure successful operation of the calibration kit. Refer to

Table 6-1 on page 6-2 for ordering information.

Offset-Short Calibration Using the 85059B (Precision) Calibration Kit and the PNA's Guided Power Calibration

NOTE

IMPORTANT! The 85059B calibration kit must be used with the PNA's Guided Calibration. PNA's guided calibration selects the proper standards for connection based on the selected frequency range. Refer to **"Using a Network Analyzer"** on page 1-6.

To download a copy of the 85059B calibration kit definitions (.xkt file), refer to Keysight's Calibration Kit Definitions Web page at <http://na.support.keysight.com/pna/caldefs/stddefs.html>

For best measurement results, the isolation standard should be the equivalent impedance of the DUT.

Calibration Residual Error Specifications

Please download our free Vector Network Analyzer Uncertainty Calculator from http://www.keysight.com/find/na_calculator.

Table 1-1 85059B (Precision) Residual System Calibration Error Specifications

Frequency Range (GHz)	Data-Based Model (Residuals) ¹		
	Directivity	Source Match	Reflection Tracking
DC to 10	-29	-28	0.02
10 to 15	-31	-31	0.09
15 to 20	-35	-35	0.09
20 to 30	-37	-36	0.05
30 to 40	-37	-35	0.05
40 to 50	-33	-32	0.07
50 to 60	-31	-30	0.08
60 to 70	-31	-30	0.15
70 to 80	-28	-27	0.15
80 to 100	-28	-27	0.11
100 to 115	-27	-27	0.13
115 to 120	-27	-27	0.13

1. Refer to “Data-Based Model for Defining the Calibration Standards” on page 1-3.

Serial Numbers

Serial Number Prefix

NOTE

IMPORTANT!

Starting in March 2021 serial number prefixes \geq US6111 have a new offset Open -m- and -f- which meet the same electrical specifications as the old serial number prefix US5720 opens. The changes made effect mechanical behavior and manufacturability.

A serial number label is attached to the calibration kit. A typical kit serial number label is shown in Figure 1-2. The prefix is made up of six characters. The first two characters show the country, the next two digits represent the year, and the last two digits designate the week of manufacturing.

Serial Number Suffix

The last four digits are the suffix numbers. The suffix numbers are unique to each calibration kit.

Figure 1-2

Typical Kit Serial Number Label

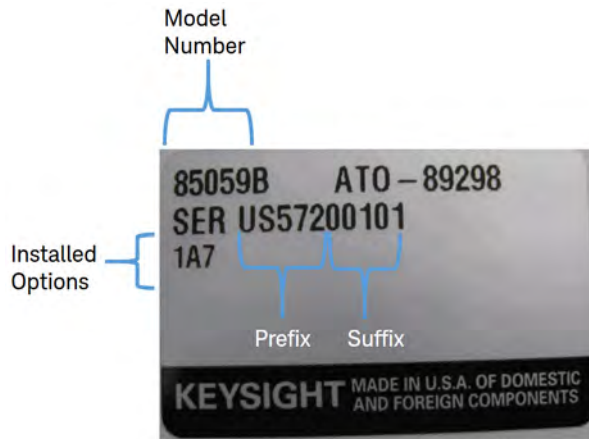

Device Serial Numbers

In addition to the kit serial number, the devices in this kit are individually serialized (serial numbers are printed on an attached label, or scribed onto the body of each device). Record these serial numbers in Figure 1-6 on page 1-16. This can help you avoid confusing the devices in this kit with similar devices from other kits.

Recording the Device Serial Numbers

Table 1-2 Serial Number Record for 85059B (Precision)

Device	Serial Number
Calibration kit	_____
Load -m-	_____
Load -f-	_____
Offset open -m-	_____
Offset open -f-	_____
1.3 mm offset short 1 -m-	_____
1.3 mm offset short 1 -f-	_____
2.45 mm offset short 2 -m-	_____
2.45 mm offset short 2 -f-	_____
3.326 mm offset short 3 -m-	_____
3.326 mm offset short 3 -f-	_____
4.039 mm offset short 4 -m-	_____
4.039 mm offset short 4 -f-	_____
Adapter m-f	_____
Adapter m-m	_____
Adapter f-f	_____

Incoming Inspection

Verify that the shipment is complete by referring to [Table on page 6-2](#) or [Figure 6-1 on page 6-3](#).

Check for damage. The foam-lined storage case provides protection during shipping.

If the case or any device appears damaged, or if the shipment is incomplete, contact Keysight. See [“Contacting Keysight” on page 5-4](#). Keysight will arrange for repair or replacement of incomplete or damaged shipments without waiting for a settlement from the transportation company.

When you send the kit or device to Keysight, include the following information:

- your company name and address
- the name of a technical contact person within your company, and the person's complete phone number
- the model number and serial number of the kit

General Information
Incoming Inspection

- the part number and serial number of the device
- the type of service required
- a **detailed** description of the problem

Clarifying Connector Gender

In this manual, connectors are referred to in terms of their device gender unless otherwise stated. For example, a male open has a male connector.

Figure 1-3 Clarifying Connector Gender

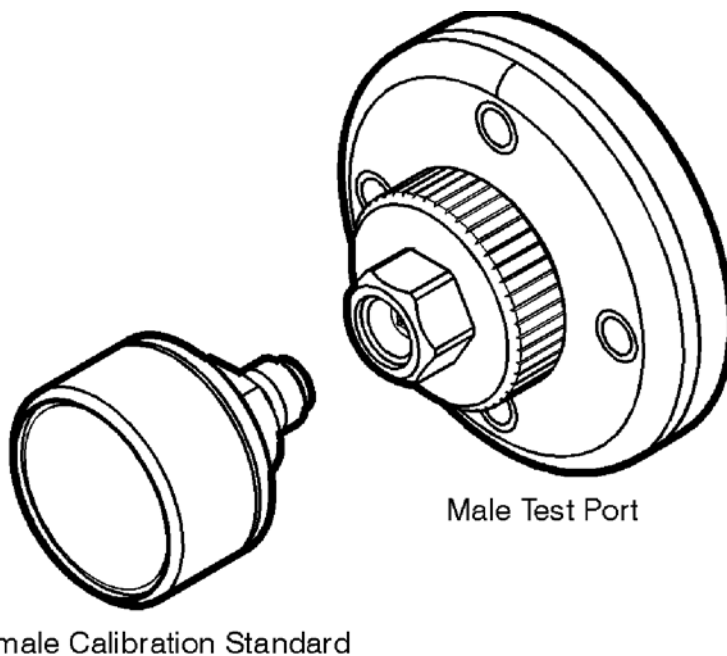

Figure 1-4 Male and Female Connectors



Clarifying the Terminology of a Connector Interface

In this document and in the prompts of the PNA calibration wizard, the sex of cable connectors and adapters is referred to in terms of the center conductor. For example, a connector or device designated as 1.0 mm –f– has a 1.0 mm female center conductor.

Preventive Maintenance

The best techniques for maintaining the integrity of the devices in this kit include:

- routine visual inspection
- cleaning
- proper pin depth
- proper connection techniques

All of the above are described in **Chapter 3, “Use, Maintenance, and Care of the Devices.”** Failure to detect and remove fSdirt or metallic particles on a mating plane surface can degrade repeatability and accuracy and can damage any connector mated to it. Improper connections, resulting from pin depth values being out of the **typical** limits (see **Table 2-4**), or from bad connections, can also damage these devices.

When to Calibrate

A network analyzer calibration remains valid as long as the changes in the systematic error are insignificant. This means that changes to the uncorrected leakages (directivity and isolation), mismatches (source match and load match), and frequency response of the system are small (<10%) relative to accuracy specifications.

Change in the environment (especially temperature) between calibration and measurement is the major cause in calibration accuracy degradation. The major effect is a change in the physical length of external and internal cables. Other important causes are dirty and damaged test port connectors and calibration standards. If the connectors become dirty or damaged, measurement repeatability and accuracy is affected. Fortunately, it is relatively easy to evaluate the general validity of the calibration. To test repeatability, remeasure one of the calibration standards. If you can not obtain repeatable measurements from your calibration standards, maintenance needs to be performed on the test port connectors, cables and calibration standards. Also, maintain at least one sample of the device under test or some known device as your reference device. A verification kit may be used for this purpose. After calibration, measure the reference device and note its responses. Periodically remeasure the device and note any changes in its corrected response which can be attributed to the test system. With experience you will be able to see changes in the reference responses that indicate a need to perform the measurement calibration again.

Regulatory and Environmental Information

This section contains information that is required by various government regulatory agencies.



The CE mark is a registered trademark of the European Community. (If accompanied by a year, it is when the design was proven.)

ccr.keysight@key
sight.com

The Keysight email address is required by EU directives applicable to our product.



China RoHS regulations include requirements related to packaging, and require compliance to China standard GB18455-2001.



This symbol indicates compliance with China RoHS regulations for paper/fiberboard packaging.

General Information
Regulatory and Environmental Information

2 Specifications

Information in This Chapter

Chapter Two at-a-Glance

Section Title	Summary of Content
“Environmental Requirements” on page 2	Describes the operating and storage environmental conditions for your calibration kit.
“Mechanical Characteristics” on page 3	A discussion of the mechanical characteristics of the calibration devices including: temperature.
“Electrical Specifications” on page 4	A discussion of the electrical specifications of the calibration devices.

Environmental Requirements

Table 2-1 Environmental Requirements

Parameter	Limits
Operating temperature ^a	+20 °C to +26 °C (+68 °F to +79 °F)
Error-corrected temperature range ^b	±1 °C of measurement calibration temperature
Storage temperature	−40 °C to +75 °C (−40 °F to +167 °F)

- The temperature range over which the calibration standards maintain conformance to their specifications.
- The allowable network analyzer ambient temperature drift during measurement calibration and during measurements when the network analyzer error correction is turned on. Also, the range over which the network analyzer maintains its specified performance while correction is turned on.

Temperature—What to Watch Out For

Changes in temperature can affect electrical characteristics. Therefore, the operating temperature is a critical factor in performance. During a measurement calibration, the temperature of the calibration devices must be stable and within the range specified in [Table 2-1](#).

NOTE

IMPORTANT! Avoid unnecessary handling of the devices during calibration because your fingers are a heat source.

Performance verification and measurements of devices under test need not be performed within the operating temperature range of the calibration devices, but they must be within the error-corrected temperature of the network analyzer (± 1 °C of the measurement calibration temperature). For example, if the calibration is performed at +20 °C, the error-corrected temperature range is +19 °C to +21 °C. It is then appropriate to perform measurements and performance verifications at +19 °C, which is outside the operating temperature range of the calibration devices, since only the actual calibration must be performed within the operating temperature range.

Mechanical Characteristics

Mechanical characteristics such as center conductor protrusion and pin depth are not performance specifications. They are, however, important supplemental characteristics related to electrical performance. Keysight Technologies verifies the mechanical characteristics of the devices in this kit with special gaging processes and electrical testing. This ensures that the device connectors do not exhibit any improper pin depth when the kit leaves the factory.

Electrical Specifications

The electrical specifications in **Table 2-2** apply to the devices in your calibration kit when connected with a Keysight precision interface.

Table 2-2 85059B (Precision) Electrical Specifications for 1.0 mm Devices

Device	Frequency (GHz)	Parameter
Data-Based Model		
		Deviation from Nominal Phase (degrees)
Short 1, 2, 3, & 4 Male and Female	DC to 20	1.50
	20 – 50	2.30
	50 – 80	3.25
	80 – 100	3.50
	100 – 120	4.00
Open Male and Female	DC to 20	2
	20 – 50	3
	50 – 80	7
	80 – 100	8
	100 – 120	8
Device	Frequency (GHz)	Parameter
		Return Loss (dB)
Load Male and Female	DC to 18	30
	18 to 40	26
	40 to 50	24

Table 2-2 (Continued) 85059B (Precision) Electrical Specifications for 1.0 mm Devices

Device	Frequency	Parameter	
	(GHz)		
Data-Based Model			
Device	Frequency	Parameter	
	(GHz)	Return Loss (dB)	Insertion Loss (dB) (typical)
Adapters	DC to 20	24	-0.5
	20 to 50	20	-0.5
	50 to 75	18	-0.5
	75 to 110	14	-0.5
	110 to 120	14	-0.7

Certification

Keysight Technologies certifies that this product met its published specifications at the time of shipment from the factory. Keysight further certifies that its calibration measurements are traceable to the United States National Institute of Standards and Technology (NIST) to the extent allowed by the institute's calibration facility, and to the calibration facilities of other International Standards Organization members. See **“How Keysight Verifies the Devices in This Kit” on page 4-2** for more information.

3 Use, Maintenance, and Care of the Devices

Information in this Chapter

Chapter Three at-a-Glance

Section Title	Summary of Content
“Electrostatic Discharge” on page 2	How to protect your instruments and devices against electrostatic discharge.
“Visual Inspection” on page 4	A discussion of visually inspecting your verification kit’s contents.
“Cleaning Connectors” on page 8	How to clean your connectors.
“Pin Depth” on page 10	How to verify the pin depth of you male and female devices.
“Making Connections” on page 12	Discussion of making connections. Includes a discussion of proper torquing procedures and properly separate connections.
“Using a Torque Wrench” on page 15	How to use a torque wrench for consistent measurements and avoiding damaging a device.
“Disconnection Procedure” on page 19	Discussion of how to disconnect your devices and how to avoid damaging your devices while torquing.
“Handling and Storage” on page 19	What the system verification does. How to perform the verification test. How to interpret the results.

Electrostatic Discharge

Protection against ESD (electrostatic discharge) is essential while connecting, inspecting, or cleaning connectors attached to a static-sensitive circuit (such as those found in test sets).

Static electricity can build up on your body and can easily damage sensitive internal circuit elements when discharged. Static discharges too small to be felt can cause permanent damage. Devices such as calibration components and devices under test (DUTs), can also carry an electrostatic charge. To prevent damage to the test set, components, and devices:

- **always** wear a grounded wrist strap having a 1 M Ω resistor in series with it when handling components and devices or when making connections to the test set.
- **always** use a grounded, conductive table mat while making connections.
- **always** wear a heel strap when working in an area with a conductive floor. If you are uncertain about the conductivity of your floor, wear a heel strap.
- **always** ground yourself before you clean, inspect, or make a connection to a static-sensitive device or test port. You can, for example, grasp the grounded outer shell of the test port or cable connector briefly.
- **always** ground the center conductor of a test cable before making a connection to the analyzer test port or other static-sensitive device. This can be done as follows:
 1. Connect a short (from your calibration kit) to one end of the cable to short the center conductor to the outer conductor.
 2. While wearing a grounded wrist strap, grasp the outer shell of the cable connector.
 3. Connect the other end of the cable to the test port.
 4. Remove the short from the cable.

Refer to **Chapter 6, “Replacement Parts.”** for part numbers and instructions for ordering ESD protection devices.

Figure 3-1 ESD Protection Setup

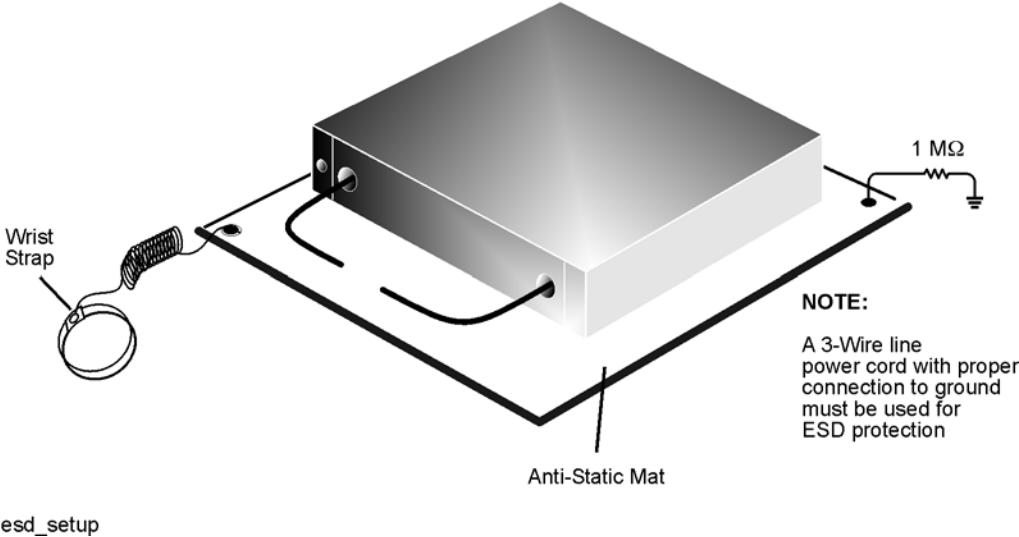

Visual Inspection

Visual inspection and, if necessary, cleaning should be done every time a connection is made. Metal particles from the connector threads may fall into the connector when it is disconnected. One connection made with a dirty or damaged connector can damage both connectors beyond repair.

CAUTION

Devices with damaged connectors should be immediately discarded or clearly marked and set aside for repair. A damaged device will in turn damage any good connector to which it is attached. Determine the cause of the damage before connecting a new, undamaged connector in the same configuration.

Magnification is helpful when inspecting connectors, but it is not required and may actually be misleading. Defects and damage that cannot be seen without magnification generally have no effect on electrical or mechanical performance. Magnification is of great use in analyzing the nature and cause of damage and in cleaning connectors, but it is not required for inspection.

Look for Obvious Defects and Damage First

Examine the connectors first for obvious defects and damage:

- Plating
 - Bare metal showing
 - Burrs or blisters
- Deformed threads
- Center conductors
 - Bent
 - Broken
 - Misaligned
 - Concentricity

Connector nuts should move smoothly and be free of:

- Burrs
- Loose metal particles
- Rough spots

Any connector that has obvious defects should be discarded or sent for repair - refer to **“Contacting Keysight” on page 5-4.**

What Causes Connector Wear?

Connector wear is caused by connecting and disconnecting the devices. The more use a connector gets, the faster it wears and degrades. The wear is greatly accelerated when connectors are not kept clean, or are connected incorrectly.

Connector wear eventually degrades performance of the device. Calibration devices should have a long life if their use is on the order of a few times per week. Replace devices with worn connectors.

The test port connectors on the network analyzer test set may have many connections each day, and are therefore more subject to wear. It is recommended that an adapter be used as a test port saver to minimize the wear on the test set's test port connectors.

Connector Contacts

See **Figure 3-2 on page 3-5** for visual guidelines when evaluating the contact integrity of a connector.

NOTE

Notice the location of the cross hairs in relationship to the center of the figures.

Figure 3-2 Contact Integrity

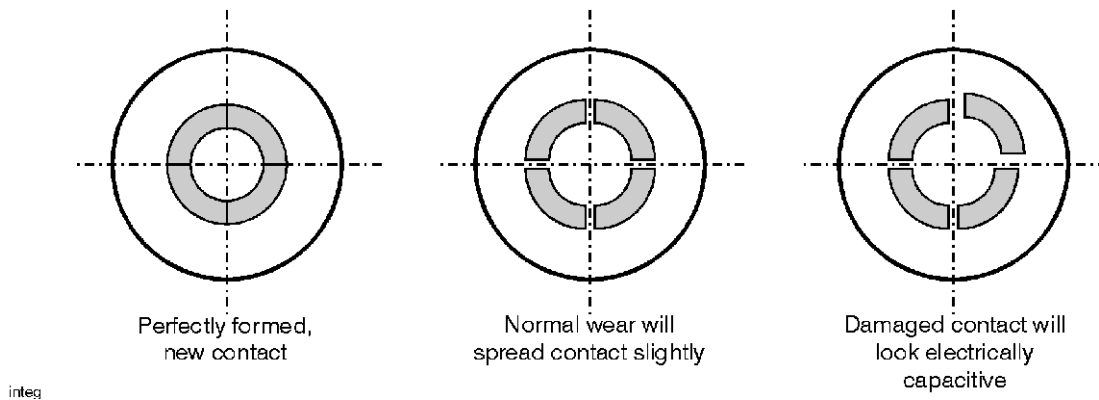

Concentricity

Figure 3-3 and **Figure 3-4** show the concentricity of both the male and female 1.0 mm connectors. Inspect the connectors with a minimum magnification of 10X.

Figure 3-3 Concentricity of a Female Connector

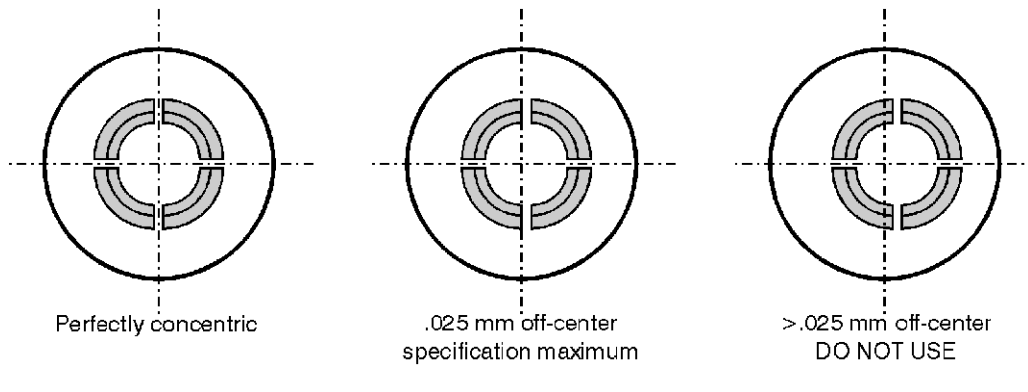
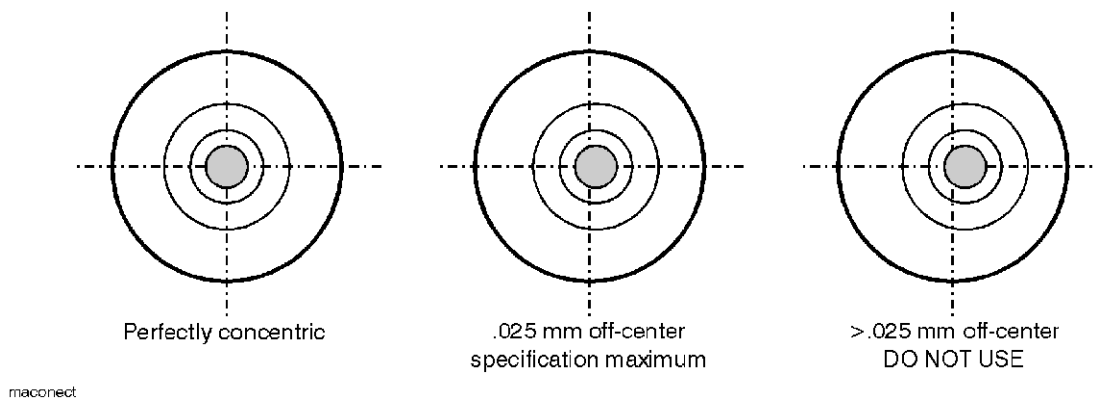

Figure 3-4 Concentricity of a Male Connector



Inspect the Mating Plane Surfaces

Flat contact between the connectors at all points on their mating plane surfaces is required for a good connection. See [Figure 3-6 on page 3-10](#).

Look especially for deep scratches or dents, and for dirt and metal particles on the connector mating plane surfaces. Also, look for “dings” on the mating plane surfaces of the center and outer conductors, and look for signs of damage due to excessive or uneven wear or misalignment.

Light burnishing of the mating plane surfaces is normal, and is evident as light scratches or shallow circular marks distributed more or less uniformly over the mating plane surface. Other small defects and cosmetic imperfections are also normal. None of these affect electrical or mechanical performance.

Clean and inspect the connector again, if it shows:

- Deep scratches or dents
- Particles clinging to the mating plane surfaces
- Uneven wear

Devices with damaged connectors should be discarded or sent for repair. Determine the cause of damage before connecting a new, undamaged connector in the same configuration. Magnification is of great use in analyzing the nature and cause of damaged connectors.

Inspect Female Connectors

Pay special attention to the contact fingers in the female center conductor. These can be bent or broken, and damage to them is not always easy to see. A connector with damaged contact fingers will negatively affect electrical performance and must be replaced.

NOTE

Inspection is particularly important when mating nonprecision to precision devices.

Supplies and Equipment Needed

The supplies and equipment needed to perform the cleaning procedure, and their Keysight Technologies part numbers are listed in Table 7-1 on page 7-2 and page 7-3.

Cleaning Connectors

Clean connectors are essential for ensuring the integrity of RF and microwave coaxial connections.

1. Use Compressed Air or Nitrogen

Clean connectors are essential for ensuring the integrity of RF and microwave coaxial connections.

WARNING

Always use protective eyewear when using compressed air or nitrogen.

Use compressed air (or nitrogen) to loosen particles on the connector mating plane surfaces.

You can use any source of clean, dry, low-pressure compressed air or nitrogen that has an effective oil-vapor filter and liquid condensation trap placed just before the outlet hose.

Ground the hose nozzle to prevent electrostatic discharge, and set the air pressure to less than 414 kPa (60 psi) to control the velocity of the air stream. High-velocity streams of compressed air can cause electrostatic effects when directed into a connector. These electrostatic effects can damage the device. Refer to **“Electrostatic Discharge”** on page 3-2 earlier in this chapter for additional information.

2. Clean the Connector Threads

WARNING

Keep isopropyl alcohol away from heat, sparks, and flame. Store in a tightly closed container. It is extremely flammable. In case of fire, use alcohol foam, dry chemical, or carbon dioxide; water may be ineffective.

Use isopropyl alcohol with adequate ventilation and avoid contact with eyes, skin, and clothing. It causes skin irritation, may cause eye damage, and is harmful if swallowed or inhaled. It may be harmful if absorbed through the skin. Wash thoroughly after handling.

In case of spill, soak up with sand or earth. Flush spill area with water.

Dispose of isopropyl alcohol in accordance with all applicable federal, state, and local environmental regulations.

Use a lint-free swab or cleaning cloth moistened with isopropyl alcohol to remove any dirt or stubborn contaminants on a connector that cannot be removed with compressed air or nitrogen. Refer to **Table 6-2** on page 6-4 for a part numbers for cleaning swabs.

- a. Apply a small amount of isopropyl alcohol to a lint-free cleaning swab.
- b. Clean the connector threads.
- c. Let the alcohol evaporate, then blow the threads dry with a gentle stream of clean, low-pressure compressed air or nitrogen. Always completely dry a connector before you reassemble or use it.

3. Clean the Mating Plane Surfaces

- a. Apply a small amount of isopropyl alcohol to a lint-free cleaning swab.
- b. **Gently** clean the center and outer conductor mating plane surfaces. Refer to [Figure 3-6 on page 3-10](#). When cleaning a female connector, avoid snagging the swab on the center conductor contact fingers by using short strokes.
- c. Let the alcohol evaporate, then blow the connector dry with a gentle stream of clean, low-pressure compressed air or nitrogen. Always completely dry a connector before you reassemble or use it.

4. Reinspect

Inspect the connector again to make sure that no particles or residue are present.

Figure 3-5 Cleaning Illustration

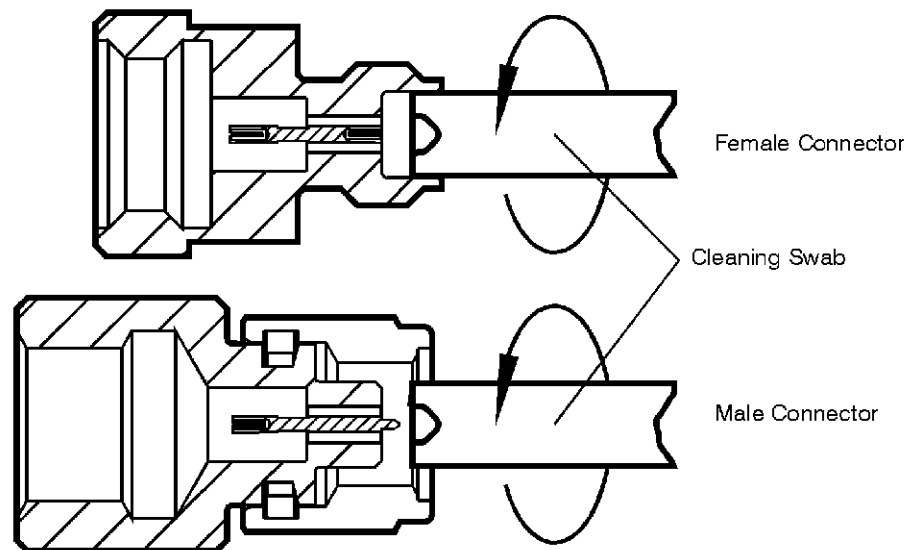

cleaning

Pin Depth

Pin depth is the distance the center conductor mating plane differs from being flush with the outer conductor mating plane. See [Figure 3-6](#). The pin depth of a connector can be in one of two states: either protruding or recessed.

- Protrusion is the condition in which the center conductor extends beyond the outer conductor mating plane. This condition will indicate a positive value on the connector gage.

CAUTION

At no time should the pin depth of the 1.0 mm connector be protruding.

- Recession is the condition in which the center conductor is set back from the outer conductor mating plane. This condition will indicate a negative value on the connector gage.

Figure 3-6 Connector Pin Depth

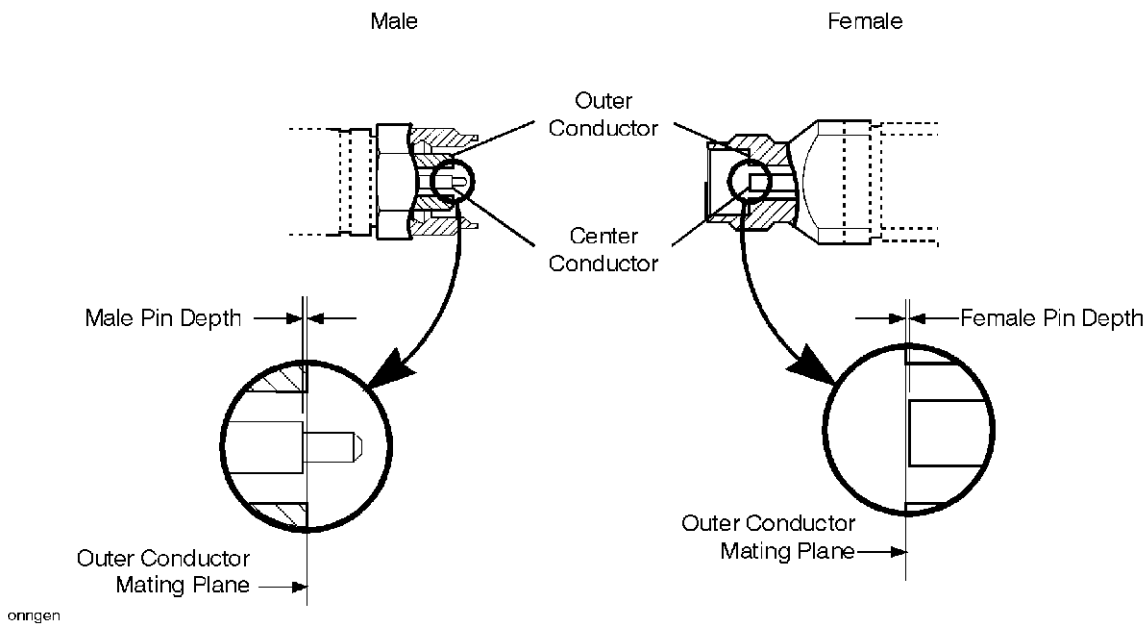

The pin depth value of each calibration device in the kit is not specified, but is an important mechanical parameter. The electrical performance of the device depends, to some extent, on its pin depth.

Keysight verifies the pin depth characteristics of the connectors in this kit with special gaging processes and electrical testing. This ensures that the device connectors do not exhibit any center conductor protrusion and have proper pin depth when the kit leaves the factory.

Use, Maintenance, and Care of the Devices Pin Depth

The electrical specifications for each device in the kit take into account the effect of pin depth on the device's performance. [Table 3-1 on page 3-11](#) lists the typical pin depths for the devices in the kit. If the pin depth of a device does not measure within the **typical** pin depth limits, it may be an indication that the device fails to meet electrical specifications. Refer to [Figure 3-6 on page 3-10](#) for a visual representation of proper pin depth (slightly recessed).

Table 3-1 Pin Depth Limit

Device	Typical Pin Depth
Opens	-0.003 to -0.024 mm -0.00011 to -0.00094 in
Shorts	-0.003 to -0.011 mm -0.00011 to -0.00043 in
Fixed Loads	-0.0020 to -0.020 mm -0.000079 to -0.00078 in
Adapters	-0.004 to -0.024 mm -0.00016 to -0.00094 in

Making Connections

Good connections require a skilled operator. Instrument sensitivity and coaxial connector mechanical tolerances are such that slight errors in operator technique can have a significant effect on measurements and measurement uncertainties.

NOTE

The most common cause of measurement error is poor connections.

How to Make a Connection

Connection Procedure

1. Ground yourself and all devices. Wear a grounded wrist strap and work on a grounded, conductive table mat. Refer to [“Electrostatic Discharge” on page 3-2](#) for ESD precautions.
2. Visually inspect the connectors. Refer to [“Visual Inspection” on page 3-4](#).
3. If necessary, clean the connectors. Refer to [“Cleaning Connectors” on page 3-8](#).
4. Carefully align the connectors. The male connector center pin must slip concentrically into the contact finger of the female connector.
5. Push the connectors straight together. Do not twist or screw them together. As the center conductors mate, there is usually a slight resistance.

CAUTION

Do **not** twist one connector into the other (like inserting a light bulb). This happens when you turn the device body, rather than the connector nut. **Major damage** to the center conductor and the outer conductor can occur if the device body is twisted.

6. Initial tightening can be done by hand, or with a 6 mm open-end wrench. Tighten until “snug” or where the connectors are first making contact. The preliminary connection is tight enough when the mating plane surfaces make uniform, light contact. Do not overtighten this connection.

At this point, all you want is for the outer conductors to make gentle contact on both mating surfaces. Use very light finger pressure (no more than 2 inch-pounds of torque).

7. Relieve any side pressure on the connection from long or heavy devices, or cables. This assures consistent torque (refer to [“Using a Torque Wrench” on page 3-15](#)).

Figure 3-7 Alignment

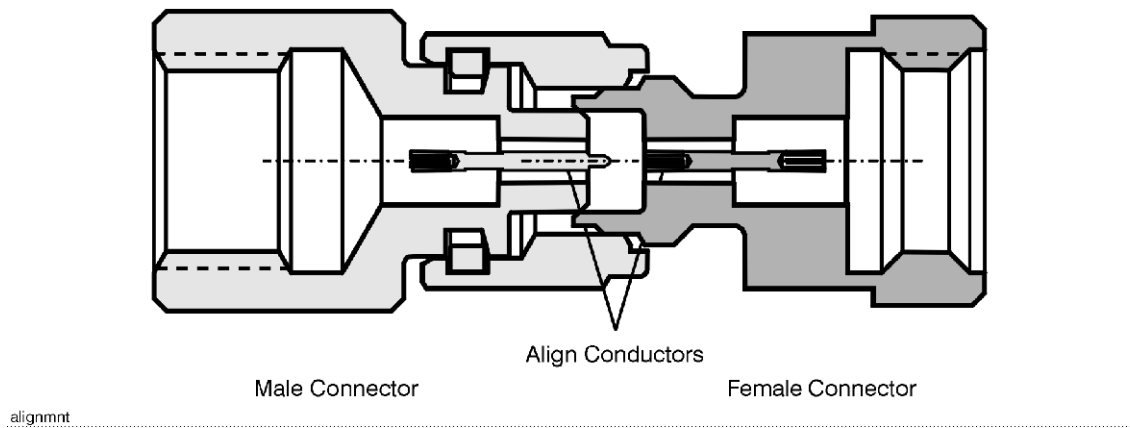

Connector Misalignment

Forced misalignment could damage the female center conductor.

Figure 3-8 Misalignment

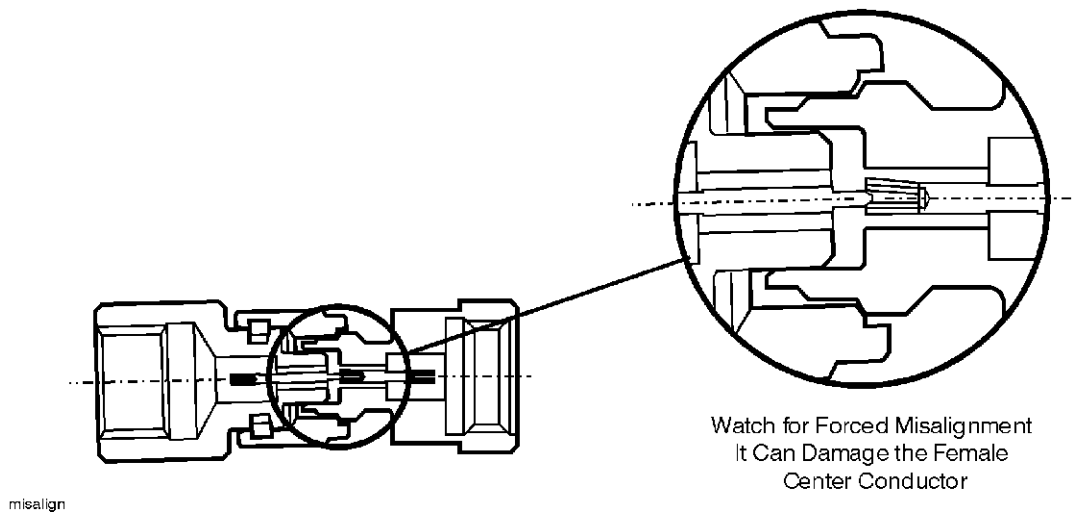

How to Separate a Connection

To avoid lateral (bending) force on the connector mating plane surfaces, always support the devices and connections.

CAUTION

Turn the connector nut, **not** the device body. Major damage to the center conductor can occur if the device body is twisted.

1. Use an open-end wrench to prevent the device body from turning.
2. Use another open-end wrench to loosen the connector nut.

- 3. Complete the separation by hand, turning only the connector nut.**
- 4. Pull the connectors straight apart without twisting, rocking, or bending either of the connectors.**

Using a Torque Wrench

Use a torque wrench to make a final connection. [Table 3-2](#) provides information about the torque wrench recommended for use with this calibration kit. Refer to [Table 6-1 on page 6-2](#) for part number and ordering information.

Table 3-2 Torque Wrench Information

Connector Type	Torque Setting	Torque Tolerance
1.0 mm	45 N-cm (4 in-lb)	± 5.4 N-cm (± 0.5 in-lb)

Using a torque wrench guarantees that the connection is not too tight, preventing possible connector damage. It also guarantees that all connections are equally tight each time. [Table 3-9 on page 3-16](#) shows you where to hold the torque wrench for optimum performance.

NOTE

Do not pre-tighten the connector nut so much that there is no rotation of the nut with the torque wrench. Static friction must *not* be present during torquing.

1. Use the torque wrench supplied with your kit to make the final connections.
2. Rotate **only** the connector nut when you tighten the connector.

In all situations, use an open-end wrench to keep the body of the device from turning. Position both wrenches within 90 degrees of each other before applying force (see [Table 3-10 on page 3-16](#)). Wrenches opposing each other (180 degrees apart) will cause a lifting action. This lifting action can misalign, and stress the connections of the devices involved. This is especially true when several devices are connected together.

Figure 3-9 Correct Wrench Position

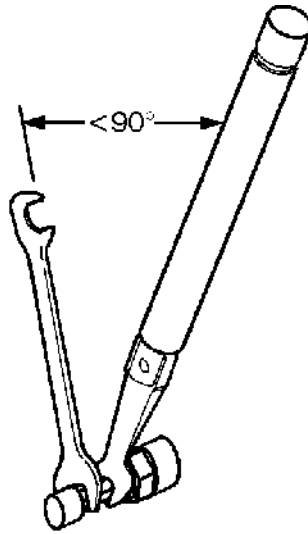

wj67d

Narrow separation of the wrenches produces a small residual lateral force on the structure of connected devices.

Figure 3-10 Incorrect Torque Wrench

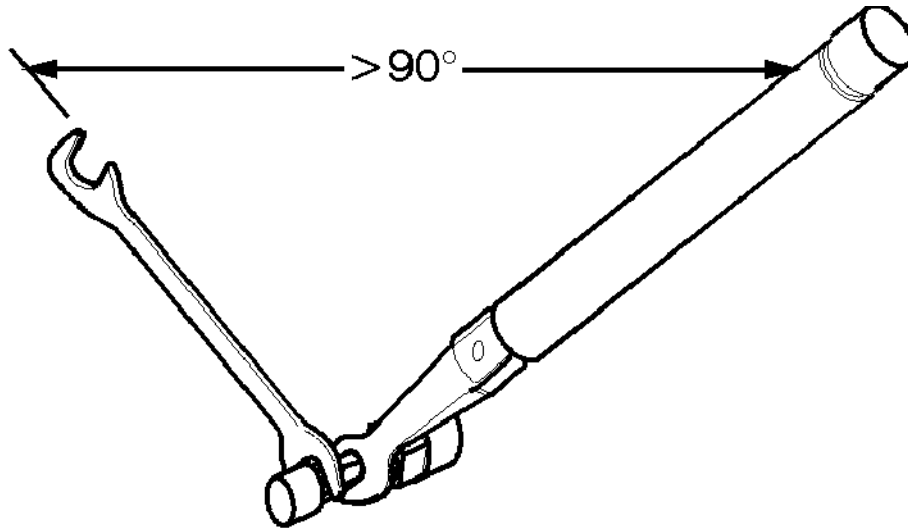

Wide separation of the wrenches produces a larger residual lateral force on the structure of connected devices. This can degrade connector repeatability.

3. Hold the torque wrench lightly, at the end of the handle only (beyond the groove). See [Figure 3-11 on page 3-17](#).

Figure 3-11 Where to Hold the Torque Wrench

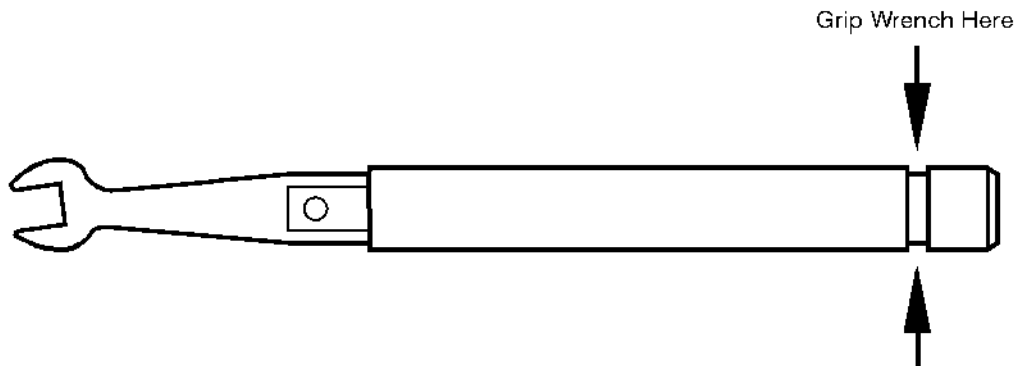

4. Apply downward force perpendicular to the wrench handle. See **Figure 3-12**. This applies torque to the connection **through** the wrench.

Do **not** hold the wrench so tightly that you push the handle straight down along its length rather than pivoting it, otherwise you apply an unknown amount of torque.

Figure 3-12 Using the Torque Wrench

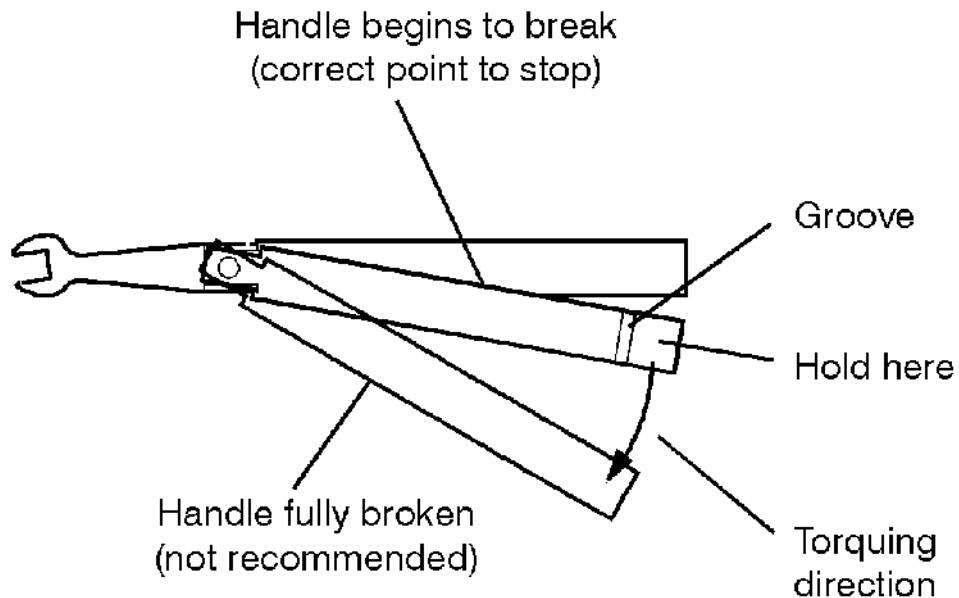

5. Tighten the connection just to the torque wrench "break" point. The wrench handle gives way at its internal pivot point. See **Figure 3-12**. Do **not** tighten the connection further.

CAUTION

You don't have to fully break the handle of the torque wrench to reach the specified torque; doing so can cause the handle to kick back and loosen the connection. Any give at all in the handle is sufficient torque.

Do not pivot the wrench handle on your thumb or other fingers, otherwise you apply an unknown amount of torque to the connection when the wrench reaches its break point.

Do not twist the head of the wrench relative to the outer conductor mating plane. If you do, you apply more than the recommended torque.

Disconnection Procedure

To avoid lateral (bending) force on the connector mating plane surfaces, always support the devices and connections.

1. Use an open-end wrench to prevent the device body from turning.
2. Use another wrench to loosen the connector nut.
3. Complete the disconnection by hand, turning only the connector nut.

CAUTION

Do **not** twist one connector out of the other, (like removing a light bulb). Turn the connector nut, not the device body. Major damage to the center conductor and the outer conductor can occur if the device body is twisted.

4. Pull the connectors straight apart without twisting or bending.

Handling and Storage

- Install the protective end caps and store the calibration devices in the foam-lined storage case when not in use.
- Never store connectors loose in a box, desk, or bench drawer. This is the most common cause of connector damage during storage.
- Keep connectors clean.
- Do not touch mating plane surfaces. Natural skin oils and microscopic particles of dirt are easily transferred to a connector interface and are very difficult to remove.
- Do not set connectors contact-end down on a hard surface. The plating and the mating plane surfaces can be damaged if the interface comes in contact with any hard surface.

Use, Maintenance, and Care of the Devices
Handling and Storage

4 Performance Verification

Information in This Chapter

Chapter Four at-a-Glance

Section Title	Summary of Content
“Introduction” on page 1	Overview of how to recertify the 85059B kit.
“How Keysight Verifies the Devices in This Kit” on page 2	A discussion on the steps Keysight uses to verify a calibration kit.
“Recertification” on page 2	Discusses what is provided with the recertification and how often to recertify the calibration kit.
“Where to Send a Kit for Recertification” on page 3	Where to send your kit for certification.

Introduction

The performance of your calibration kit can only be verified by returning the kit to Keysight Technologies for recertification. The equipment required to verify the specifications of the devices in the kit has been specially manufactured and is not commercially available.

How Keysight Verifies the Devices in This Kit

Keysight verifies the specifications of these devices as follows:

1. The residual microwave error terms of the test system are verified with precision airlines and shorts that are directly traced to NIST (National Institute of Standards and Technology). The airline and short characteristics are developed from mechanical measurements. The mechanical measurements and material properties are carefully modeled to give very accurate electrical representation. The mechanical measurements are then traced to NIST through various plug and ring gages and other mechanical measurements
2. Each calibration device is electrically tested on this system. For the initial (before sale) testing of the calibration devices, Keysight includes the test measurement uncertainty as a guardband to guarantee each device meets the published specification. For recertifications (after sale), no guardband is used and the measured data is compared directly with the specification to determine the pass or fail status. The measurement uncertainty for each device is, however, recorded in the calibration report that accompanies recertified kits.

These two steps establish a traceable link to NIST for Keysight to the extent allowed by the institute's calibration facility. The specifications data provided for the devices in this kit is traceable to NIST through Keysight Technologies.

Recertification

The following will be provided with a recertified kit:

- a new calibration sticker affixed to the case
- a certificate of calibration
- a calibration report for each device in the kit listing measured values, specifications, and uncertainties

NOTE

A list of NIST traceable numbers may be purchased upon request to be included in the calibration report.

Keysight Technologies offers a *Standard* calibration for the recertification of this kit. For more information, contact Keysight Technologies - refer to **“Contacting Keysight” on page 5-4.**

How Often to Recertify

The suggested initial interval for recertification is 12 months or sooner. The actual need for recertification depends on the use of the kit. After reviewing the results of the initial recertification, you may establish a different recertification interval that reflects the usage and wear of the kit.

NOTE

In some cases, the first time a kit is used after being recertified occurs some time after the actual recertification date. The recertification interval should begin on the date the kit is *first used* after the recertification date.

Where to Send a Kit for Recertification

Contact Keysight Technologies for information on where to send your kit for recertification. See **“Contacting Keysight” on page 5-4.**

Performance Verification
Where to Send a Kit for Recertification

5 Troubleshooting

Information in This Chapter

Chapter Five at-a-Glance

Section Title	Summary of Content
“Troubleshooting Process” on page 5-2	How to troubleshoot a calibration problem. Includes a flow troubleshooting diagram.
“Where to Look for More Information” on page 5-3	Where to find more information on network analyzer system operation.
“Returning a Kit or Device to Keysight” on page 5-3	Where to return a kit to Keysight and the required information.
“Contacting Keysight” on page 5-4	How to contact Keysight.

Troubleshooting Process

If you suspect a bad calibration, or if your network analyzer does not pass performance verification, follow the steps in [Figure 5-1](#).

Figure 5-1 Troubleshooting Flowchart

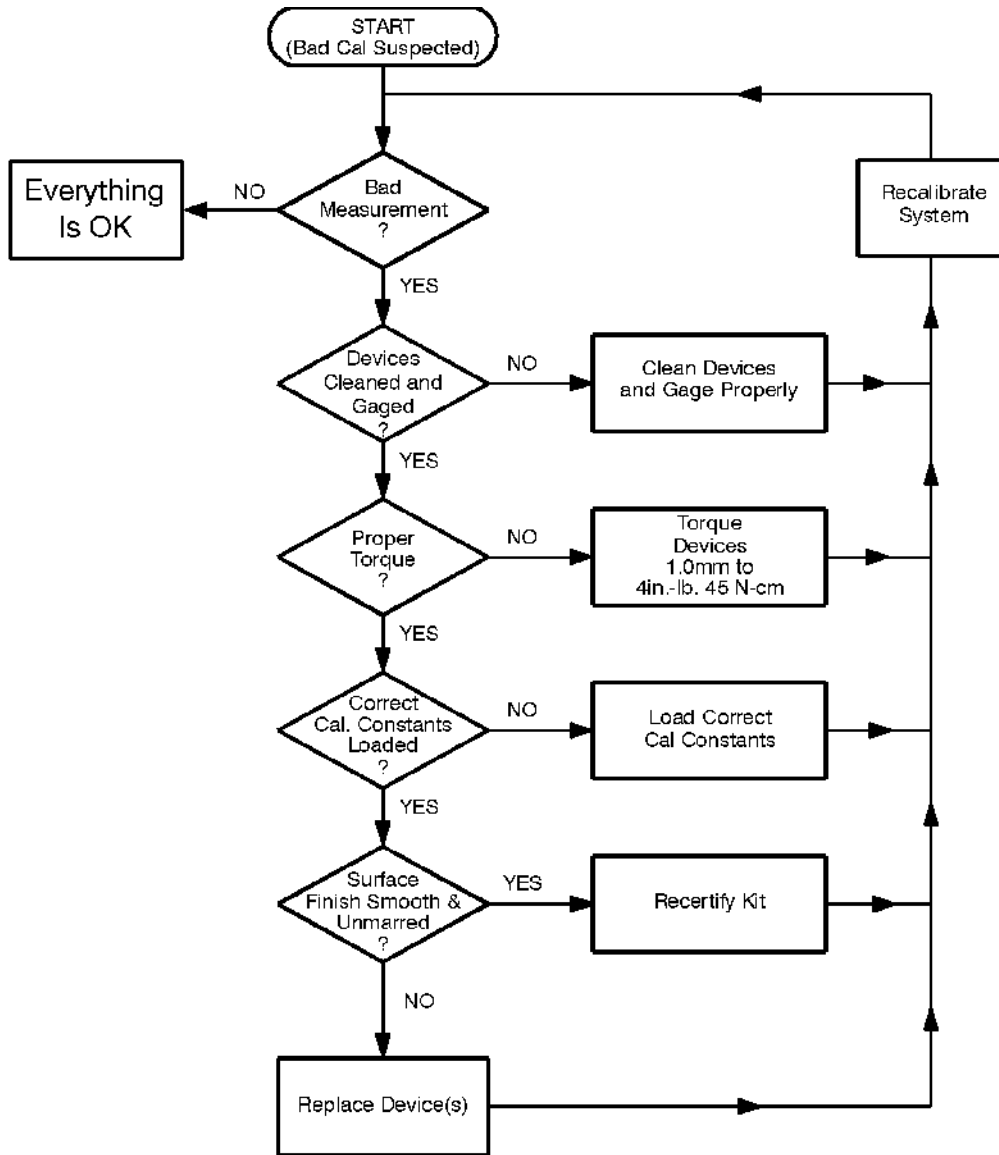

troublow

Where to Look for More Information

This manual contains limited information about network analyzer system operation. For detailed information on using an ENA or PNA series network analyzer, refer to the appropriate user guide or Help file.

- To view the ENA or PNA Help, press the Help key on the front panel of the network analyzer.
- To view Help or a user guide online, use the following steps:
 1. Go to www.keysight.com/find/assist.
 2. Enter your analyzer model number (Ex: N5242B) in the search box and press return.
 3. Under the heading of your network analyzer, click on the **Support** tab and then the **Document Library** icon.
 4. Click on the document PDF you want to view.

If you need additional information, see [“Contacting Keysight” on page 5-4](#).

Returning a Kit or Device to Keysight

If your kit or device requires service, contact Keysight Technologies for information on where to send it and provide the following:

- your company name and address
- a technical contact person within your company, and the person's complete phone number
- the model number and serial number of the kit
- the part number and serial number of each device
- the type of service required
- a **detailed** description of the problem and how the device was being used when the problem occurred (such as calibration or measurement)
- see also, [“Contacting Keysight” on page 5-4](#)

Contacting Keysight

Assistance with test and measurements needs and information on finding a local Keysight office are available on the Web at:

www.keysight.com/find/assist

If you do not have access to the Internet, please contact your Keysight field engineer.

NOTE

In any correspondence or telephone conversation, refer to the Keysight product by its model number and full serial number. With this information, the Keysight representative can determine whether your product is still within its warranty period.

Printing Copies of Documentation from the Web

To print copies of documentation from the Web, download the PDF file from the Keysight web site:

- Go to www.keysight.com.
- Enter the document's part number (located on the title page) in the Search box.
- Click Search
- Open the PDF and print the document.

6 Replacement Parts

Information in This Chapter

Chapter Six at-a-Glance

Section Title	Summary of Content
“Introduction” on page 1	A discussion of the chapter overview: <ul style="list-style-type: none">– Table of Replaceable Parts (See Table 6-1 on page 6-2)– Table of orderable parts that are not included in this kit (See Table 6-2 on page 6-4)

Introduction

NOTE

IMPORTANT!

Starting in March 2021 serial number prefixes \geq US6111 have a new offset Open -m- and -f- which meet the same electrical specifications as the old serial number prefix US5720 opens. The changes made effect mechanical behavior and manufacturability.

The following replaceable parts table lists the replacement part numbers for the 85059B calibration kit contents. To order a listed part, note the description, part number, and the quantity desired and contact Keysight Technologies - refer to [“Contacting Keysight” on page 5-4](#).

Table 6-1 Replaceable Parts for the 85059B (Precision) Calibration Kit

Description	Qty Per Kit	Keysight Part Number
Calibration Devices (1.0 mm) ^{a, b}		
1.3 mm offset short 1 –m–	1	85059-60027
2.45 mm offset short 2 –m–	1	85059-60029
3.326 mm offset short 3 –m–	1	85059-60031
4.039 mm offset short 4 –m–	1	85059-60033
1.3 mm offset short 1 –f–	1	85059-60028
2.45 mm offset short 2 –f–	1	85059-60030
3.326 mm offset short 3 –f–	1	85059-60032
4.039 mm offset short 4 –f–	1	85059-60034
Offset open –m–	1	85059-60065 Was:85059-60053
Offset open –f–	1	85059-60066 Was:85059-60054
Lowband load –m–	1	85059-60019
Lowband load –f–	1	85059-60020
Adapters (1.0 mm) ^a		
Adapter m–m	1	85059-60044
Adapter f–f	1	85059-60045
Adapter m–f	1	85059-60046
Calibration Kit Storage Case		
Box with customized foam inserts	1	1540-2330
Wrenches		
6 mm open–end wrench	1	8710-2156
6 mm, 45 N–cm (4 in–lb) torque wrench	1	8710-2812
14 mm, 45 N–cm (4 in–lb) torque wrench	1	8710-2813
Miscellaneous Items		
Operation and Service Guide	1	85059-90005 ^c
10x Magnifying Glass	1	1000-1114
Protective end caps	as required	1401-0202

- a. See [“Clarifying the Terminology of a Connector Interface”](#) on page 1-13.
- b. Refer to [“How to Identify Devices”](#) on page 1-5.
- c. Refer to [“Printing Copies of Documentation from the Web”](#) on page 5-4.

Figure 6-1 Replaceable Parts for the 85059B (Precision) Calibration Kit (not all items are shown below. For a complete list, refer to [See “Replaceable Parts for the 85059B \(Precision\) Calibration Kit”](#) on page 2.)

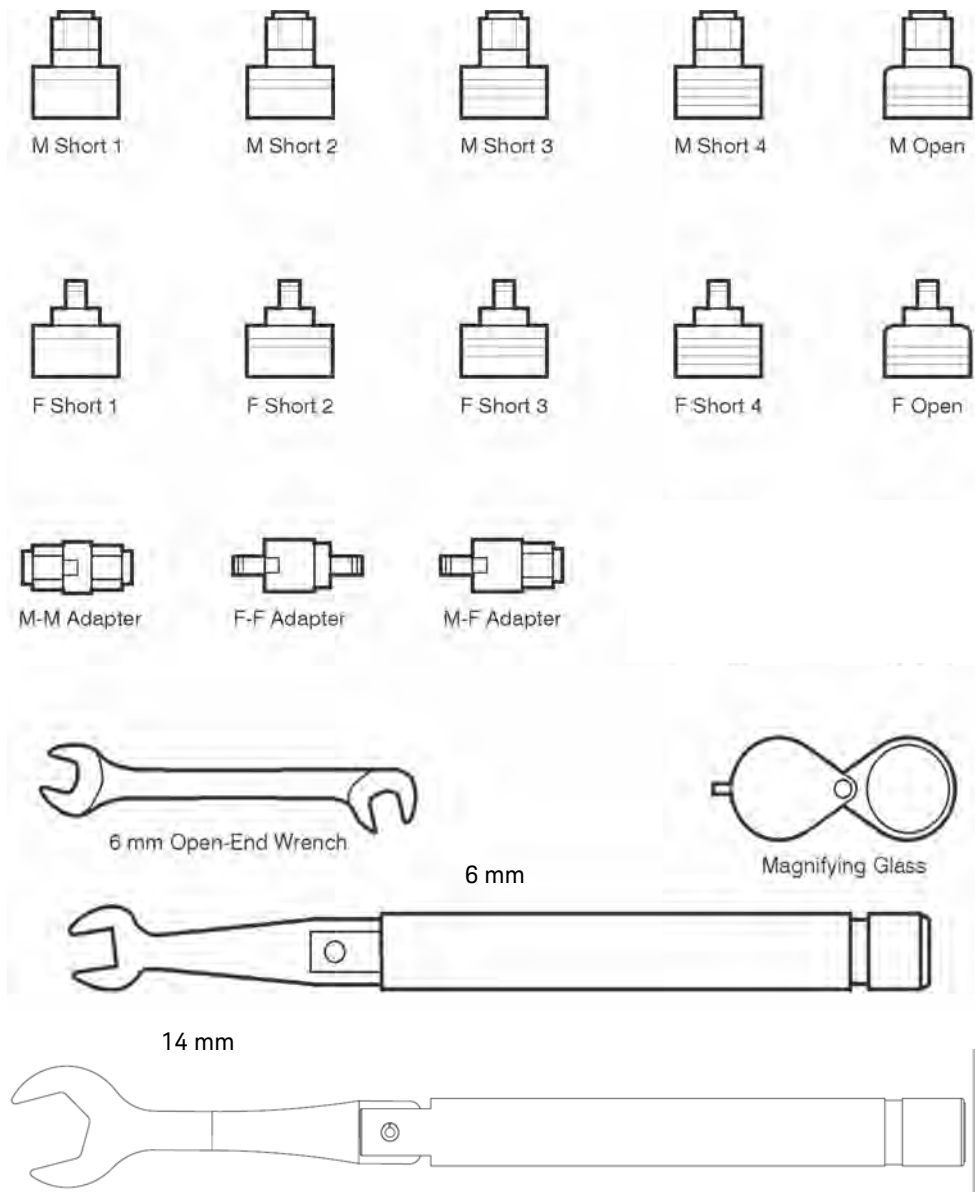

Table 6-2 **Items Not Included in the Calibration Kits**

Description	Qty	Keysight Part Number
Adapters ^a (50Ω)		
V-band waveguide to 1.0 mm -f- coax	1	V281C
V-band waveguide to 1.0 mm -m- coax	1	V281D
W-band waveguide to 1.0 mm -f- coax	1	W281C
W-band waveguide to 1.0 mm -m- coax	1	W281D
1 mm -m- to 1.85 mm -m-	1	11921E
1 mm -f- to 1.85 mm -f-	1	11921F
1 mm -m- to 1.85 mm -f-	1	11921G
1 mm -f- to 1.85 mm -m-	1	11921H
1.0 mm ^b -f- to 1.0 mm ^b -f- (Ruggedized)	1	Y1900B
1.0 mm ^b -f- to 1.0 mm ^b -m- (Ruggedized)	1	Y1900C
ESD Protective Devices		
Grounding wrist strap	1	9300-1367
5 ft grounding cord for wrist strap	1	9300-0980
2 ft by 4 ft conductive table mat with 15 ft grounding wire	1	9300-0797
ESD heel strap	1	9300-1308
Connector Cleaning Supplies		
Anhydrous isopropyl alcohol (>92% pure) ^c	--	--
Foam tipped cleaning swabs	100	9301-1243

- a. See **“Clarifying the Terminology of a Connector Interface” on page 1-13.**
- b. Ruggedized connector.
- c. Keysight can no longer safely ship isopropyl alcohol, so customers should purchase it locally.

7 Standard Definitions

Information in This Chapter

Chapter Seven at-a-Glance

Section Title	Summary of Content
Class Assignments and Standard Definitions Values are Available on the Web	Discussion on standard definitions and where to find more information on the web.

Class Assignments and Standard Definitions Values are Available on the Web

Class assignments and standard definitions may change as more accurate model and calibration methods are developed. You can download the most recent class assignments and standard definitions from Keysight's Calibration Kit Definitions Web page at

<http://na.support.keysight.com/pna/caldefs/stddefs.html>.

For a detailed discussion of calibration kits, refer to the Keysight Application Note, "Specifying Calibration Standards and Kits for Keysight Vector Network Analyzers." This application note covers calibration standard definitions, calibration kit content and its structure requirements for Keysight vector network analyzers. It also provides some examples of how to set up a new calibration kit and how to modify an existing calibration kit definition file. To download a free copy, go to www.keysight.com and enter literature number 5989-4840EN in the Search window.

Standard Definitions

Class Assignments and Standard Definitions Values are Available on the Web

Index

A

adapters 1-5, 1-6
 part numbers 6-4
 alcohol, isopropyl, as cleaning solvent 3-8

B

bands that identify devices 1-5

C

cal kit
 contents 1-4
 overview 1-3
 calibration
 bad 5-2
 definitions 1-6
 devices
 85059B 6-2
 frequency 1-14
 temperature 2-2
 when to perform 1-14
 calibration definitions
 entering 1-6
 permanently stored 1-6
 calibration error
 specifications
 85059B Data-Based.ckt 1-8
 calibration kit
 contents 1-4
 Keysight Application Note 7-1
 modifying definition files 7-1
 overview 1-3
 calibration kit labels
 85059B cal kit 1-7
 certification, specifications 2-6
 characteristics
 mechanical 2-3
 supplemental 2-3
 class assignments
 downloading from Keysight Web site 7-1
 cleaning connectors 3-8
 cleaning supplies 1-6
 ordering 6-4
 part numbers 6-4
 compressed air or nitrogen 3-8
 conductor
 mating plane 3-10
 connections 3-2, 3-12, 3-13

cautions in making 3-12
 disconnecting 3-13
 ESD concerns 3-12
 final 3-15
 how to make 3-12
 preliminary 3-12
 undoing 3-13
 using a torque wrench 3-15

connector
 cleaning 3-8
 cleaning supplies 6-4
 damage 3-4
 female 3-7
 life 3-4
 mating plane 3-9
 threads 3-8
 visual inspection 3-5
 wear 3-5

connector contacts
 concentricity 3-6
 integrity 3-5

contents
 kit 1-4

D

damage
 to connectors 3-4
 damage, shipment 1-10
 damaged connectors 3-4
 data-based model 1-3
 defective connectors 3-4
 definitions
 calibration 1-6
 entering 1-6
 permanently stored 1-6
 deviation from nominal phase, 85059B 2-4
 device
 conductor
 mating plane 3-10
 connecting 3-12
 disconnecting 3-13
 handling 3-19
 maintenance 1-13
 part numbers 6-4
 pin depth 3-10
 storage 3-19
 temperature 2-2

- visual inspection 3-4, 3-5
- dimensions
 - device
 - center conductor 2-3
 - outer conductor 2-3
- disconnections 3-13
- downloading class assignments & std definitions from the Web 7-1

E

- electrical specifications, 85059B 2-4
- electrostatic discharge 3-2
 - supplies
 - part numbers 6-4
 - when making connections 3-12
- environmental requirements 2-2
- equipment
 - required 1-6
 - required but not supplied 1-6
 - supplied 1-4, 6-2, 6-4
- error specifications
 - calibration
 - 85059B Data-Based.ckt 1-8
- ESD 3-2
 - precautions 3-2, 3-8
 - protection devices 1-6
 - supplies
 - part numbers 6-4
 - when making connections 3-12

F

- frequency
 - performance 1-7
 - range, 85059B 2-4
 - specifications, 85059B 2-4
- frequency of calibration 1-14

G

- gage
 - connector
 - master 6-4
- gage master
 - part numbers 6-4
- gages 1-6

H

- handling 3-19
- how often to calibrate 1-14
- how to identify calibration devices 1-5

- humidity 2-2

I

- identifying shorts, opens, & loads 1-5
- incoming inspection 1-10
- information, troubleshooting 5-3
- inspection
 - damage 3-4
 - defects 3-4
 - female connectors 3-7
 - incoming 1-10
 - mating plane 3-6
 - visual 3-4, 3-5
- isopropyl alcohol, as cleaning solvent 3-8

K

- Keysight Technologies
 - application note 7-1
- kit
 - contents 1-4
 - overview 1-3

M

- maintenance 3-2
 - preventive 1-13
- maintenance of devices 1-13
- making connections 3-12
- manual
 - part number 6-2, 6-4
- math, expanded 1-4
- mating plane
 - conductor 3-10
 - connector 3-9
 - inspection 3-6
 - surfaces 3-9
- mechanical characteristics 2-3
- mechanical integrity 2-3
- models for defining calibration standards 1-3
- modifying calibration kit definition files 7-1

N

- nitrogen 3-8

O

- offset opens 1-5
- offset shorts 1-5
- offset-short
 - calibration standards 1-7
 - calibration technique 1-7

- open-end wrench 3-13
 - part number 6-2, 6-4
- opens 1-5
- P
- parts
 - required but not supplied 6-4
- performance verification
 - fail 5-2
- pin depth 3-10
 - affect on electrical performance 3-11
 - definition of 3-10
 - effect on electrical specifications 3-11
 - importance of 3-11
 - observed limits 3-11
 - protrusion 3-10
 - recession 3-10
 - typical values 3-11
- preventive maintenance 1-13
- protrusion
 - pin depth 3-10
- R
- recertification
 - how often? 4-3
 - interval 4-3
- recession
 - pin depth 3-10
- regulations
 - environmental 3-9
- requirements
 - environmental 2-2
- return
 - kit or device to Keysight 5-3
- return loss
 - specifications, 85059B 2-4
- rings that identify devices 1-5
- S
- service 5-3
- service tag 1-10, 5-3
- shipment
 - damage 1-10
 - verifying complete 1-10
- shorts 1-5
- specifications 2-2
 - certification 2-6
 - electrical, 85059B 2-4
 - environmental 2-2
- frequency, 85059B 2-4
- humidity 2-2
- pin depth 3-11
- return loss, 85059B 2-4
- temperature 2-2
- specified frequency performance 1-7
- standard definitions
 - downloading from Keysight Web site 7-1
- standards
 - NIST 2-6
- static discharge 3-2
- storage 3-19
 - temperature 2-2
- supplemental characteristics 2-3
- supplies
 - cleaning 1-6
- T
- tag
 - service 5-3
- tag, service 1-10
- temperature
 - calibration 2-2
 - device 2-2
 - error-corrected temperature range 2-2
 - measurement 2-2
 - operating range 2-2
 - verification and measurement 2-2
- threads
 - connector 3-8
- torque wrench 3-15
 - part number 6-2, 6-4
 - specifications 3-15
- troubleshooting 5-2
- V
- verification
 - temperature 2-2
- visual inspection 3-4, 3-5
- W
- when to calibrate 1-14
- wrench
 - open-end 3-13
 - part number 6-2, 6-4
 - undoing connections 3-13
 - torque
 - part number 6-2, 6-4
- wrenches

Index

part numbers 6-2, 6-4



This information is subject to change without notice.

© Keysight Technologies 2016-2021

Edition 1, March 2021



85059-90005

www.keysight.com