

Keysight Technologies

Y1800A RF Training Kit and Lab Sheets

Data Sheet

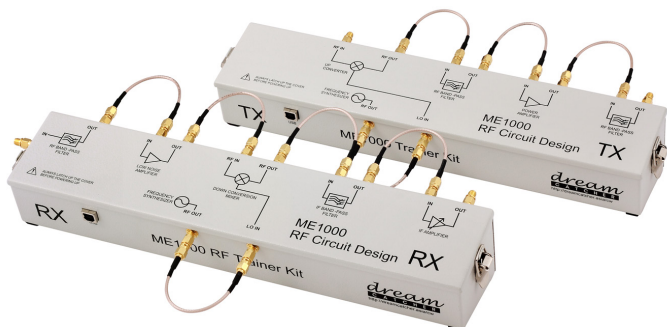

The Keysight Technologies, Inc. Y1800A RF training kit serves as a ready-to-teach package in the areas of RF principles, test & measurement, and RF communications. This is a lecturer resource consisting of RF transceiver kit, lab sheets and model answers, and problem-based assignments.

RF transceiver kit

The RF transceiver kit consists of a transmitter unit and a receiver unit in superheterodyne architecture. The transceiver units are made up of various RF building-block modules such as filter, low noise amplifier, power amplifier, mixer and oscillator. The RF transceiver kit is controlled by a Windows-based Control Panel software via USB.

Y1800A RF training kit and lab sheets

- RF transceiver kit and accessories
- Lab sheets and model answers
- Problem-based assignments

RF transceiver hardware specifications

	RF transmitter unit	RF receiver unit
RF		
Frequency synthesizer output power	-4.5 dBm (typical)	
Frequency synthesizer frequency range	816 to 880 MHz	816 to 880 MHz
Antenna frequency range	806 to 960 MHz	806 to 960 MHz
Antenna length	210 mm	210 mm
General		
Power source		USB
EMC design		Class B, Part 15 of FCC

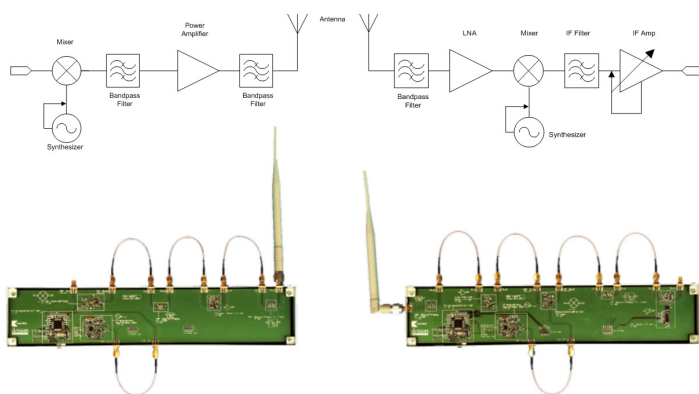

Lab sheets

The training kit includes eight lab sheets in editable Microsoft Word format. Each lab requires three hours to complete. Model answers are provided with all lab sheets.

- **Spectrum analysis** - Understanding spectrum analyzer settings
- **Spectrum analysis of frequency synthesizer and mixer** - Harmonics, intermodulation, isolation
- **Vector network analysis** - Understanding S-parameter measurements
- **Vector network analysis** - Calibration and shifting of reference planes through port extension
- **Analyzing filter and amplifier using spectrum analyzer** - Frequency response, gain compression, harmonics
- Measurement and troubleshooting of RF transceiver
- **Vector network analysis of RF filter** - Transmission, reflection, impedance on Smith chart
- **Vector network analysis of amplifier** - Gain, isolation, gain compression, AM-PM conversion

Accessories

The following accessories are provided with the training kit.

Item	Quantity
TRM standard calibration kit	1
USB cable	3
SMA(m)-to-SMA(m) jumper cable, 0.18 m	9
SMA(m)-to-SMA(m) coaxial cable, 1 m	2
N(m)-to-SMA(f) adapter	2
RF power combiner	1
Antenna	2
Ground cable, 1 m	2



Ordering information

Description	Package	Product number
Training kit	1 set	Y1800A

KEYSIGHT SERVICES

Accelerate Technology Adoption. *Lower costs.*

www.keysight.com/find/services

Keysight Services helps you improve productivity and product quality with our comprehensive service offerings of one-stop calibration, repair, asset management, technology refresh, consulting, training, and more.

This information is subject to change without notice.
 © Keysight Technologies, 2017
 Published in USA, December 1, 2017
 5992-0433EN
www.keysight.com