

Keysight Technologies

# N6467A BroadR-Reach Automotive Ethernet Electrical Compliance Application

For Infiniium Oscilloscopes

Data Sheet

Easy and accurate  
BroadR-Reach design validation  
and debug

The Keysight Technologies, Inc. N6467A BroadR-Reach automotive electrical performance validation and conformance software for Infiniium oscilloscopes provides you with an easy and accurate way to verify and debug your BroadR-Reach automotive Ethernet designs. The Ethernet electrical test software lets you automatically execute Ethernet physical-layer (PHY) electrical tests and displays the results in a flexible report format. In addition to the measurement data, the report provides a margin analysis that shows how closely your device passed or failed each test.

To make BroadR-Reach automotive Ethernet measurements with the N6467A Ethernet electrical test software, you may also need the Keysight N5395C Ethernet electrical conformance test fixture. The optional fixture is only needed when connecting with an RJ-45 cable from the customer's device, otherwise SMA cables are used to connect directly to the oscilloscope.

The N6467A Ethernet electrical test software performs a wide range of electrical tests required to meet the BroadR-Reach electrical specifications. To meet signal quality requirements, your product must successfully pass conformance testing based on these specifications. Performing these tests gives you confidence in your design. The N6467A Ethernet electrical test software helps you execute a wide subset of the conformance tests that can be measured with an oscilloscope.

## Features

The N6467A BroadR-Reach electrical performance validation and conformance software offers several features to simplify the validation of automotive Ethernet designs:

- Setup wizard for quick and clear setup, configuration and test
- Wide range of BroadR-Reach tests enabling standards conformance
- Accurate and repeatable results with Keysight Infiniium oscilloscopes
- Automated reporting in a comprehensive HTML format with margin analysis

With the N6467A electrical test software, you can use the same oscilloscope you use for everyday debugging to perform automated testing and margin analysis based on BroadR-Reach standards.

## N6467A software saves you time

The N6467A BroadR-Reach electrical test software saves you time by setting the stage for automatic execution of BroadR-Reach electrical tests. Some of the difficulties of performing electrical tests for BroadR-Reach are properly connecting to the oscilloscope, loading the proper setup files, and then analyzing the measured results by comparing them to limits published in the specification. The BroadR-Reach electrical test software does much of this work for you.

The N6467A BroadR-Reach electrical test software automatically configures the oscilloscope for each test and provides an informative results report that includes margin analysis indicating how close your product is to passing or failing that specification. See Table 2 for a complete list of the measurements made by the BroadR-Reach test software.

## Easy test definition

The N6467A BroadR-Reach electrical test software extends the ease-of-use advantages of Keysight's Infiniium oscilloscopes to testing BroadR-Reach designs. The Keysight automated test engine quickly walks you through the steps required to define the tests you want to make, set up the tests, perform the tests, and view the results. A setup page lets you quickly make decisions from the outset regarding the choice of tests and perform functions that affect the testing. The test selections available in the following steps are then filtered according to the choices made in the setup page. While selecting tests, you can select a category of tests all at once or specify individual tests. You can save tests and configurations as project files and recall them later for quick testing and review of previous test results. Straightforward menus let you perform tests with a minimum amount of mouse clicks.

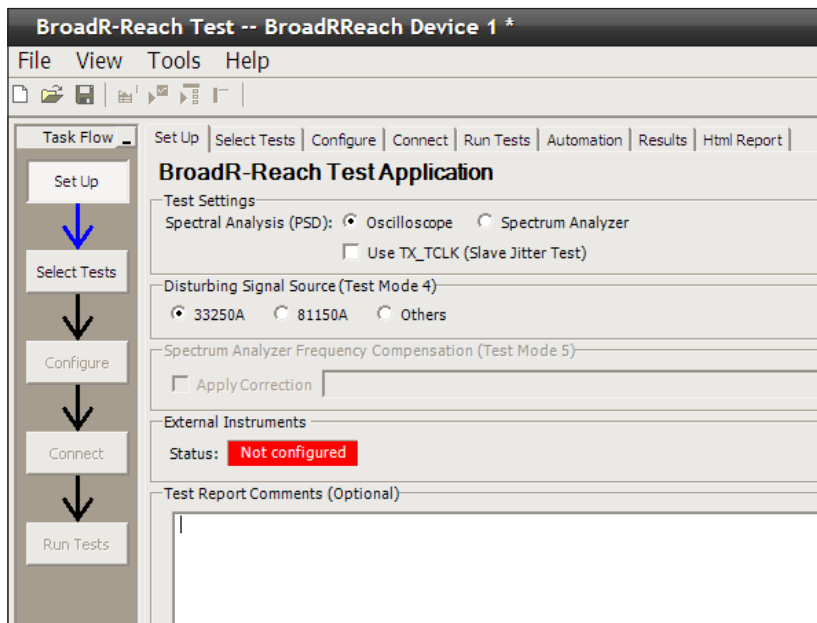

Figure 1. The clean interface allows you select BroadR-Reach tests.

## N6467A software saves you time

View all of the BroadR-Reach tests in the GUI under selected tests

- Setup wizard for quick and clear setup, configuration and test
- Clearly see all the BroadR-Reach tests
- Run single or multiple tests based on your needs
- When test is highlighted, it will show description of test along with pass limits
- Accurate and repeatable results with Keysight Infiniium oscilloscopes
- Automated reporting in a comprehensive HTML format with margin analysis



Figure 2. The Keysight automated test engine quickly guides you through selecting and configuring tests, setting up the connection, running tests, and viewing results. You can easily select individual tests or groups of tests with a mouse-click.

## Configurability and guided connections

The N6467A BroadR-Reach electrical test software provides flexibility in your test setup. It guides you to make connection changes with hookup diagrams when the tests you select require it. In most cases, connection from the customer's device to the oscilloscope will be made through an SMA cable, otherwise a Keysight N5395C Ethernet test fixture can be used with an RJ-45 connector. You then connect the oscilloscope to the test fixture using SMA cables.

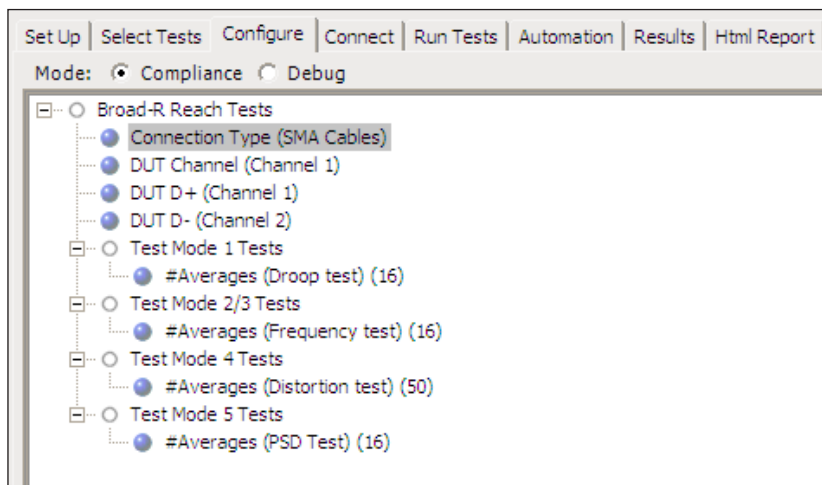

Figure 3. To set up tests, you define the device to test, its configuration, and how the oscilloscope is connected to it.

## Configurability and guided connections

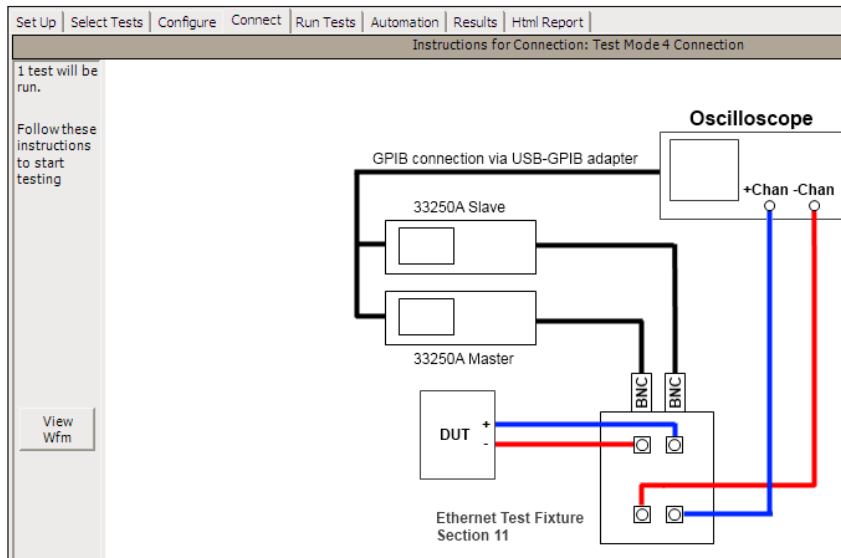

Figure 4. When you make multiple tests where the connections must be changed, the software prompts you with connection diagrams.

Step	Notes
1. Connect the DUT to the <b>Ethernet Test Fixture, Section 11</b> using a pair of SMA cables.	Connect the DUT to the SMA connectors labeled "DUT"
2. Connect the Function Generators to the <b>Ethernet Test Fixture, Section 11</b> using a pair of SMA cables.	Please calibrate the Function Generators before running the test.
3. Connect the Oscilloscope to the output of the <b>Ethernet Test Fixture, Section 11</b> .	Connect the oscilloscope to the SMA connectors labeled "Scope"
4. Configure the DUT to transmit in <b>Test Mode 4</b> .	Use the software supplied by your PHY manufacturer to control the DUT.

Example waveform:

The waveform shows two channels of a signal. The top channel is a high-frequency sine wave, and the bottom channel is a lower-frequency signal with a distinct pulse or transition. The signals are color-coded: green for the top channel and yellow for the bottom channel.

Figure 5. In the connection setup, step-by-step instructions along with expected signals are displayed to help with test setup.

## Configurability and guided connections

In addition to giving you measurement results, the N6467A BroadR-Reach electrical test software also provides a report format that shows you not only where your product passes or fails but also reports how close you are to the limits specified for a particular test. You can select the margin test report parameter, which means you can specify the level at which warnings are issued to alert you to electrical tests where your product is operating close to the official test limit defined by the BroadR-Reach specification.

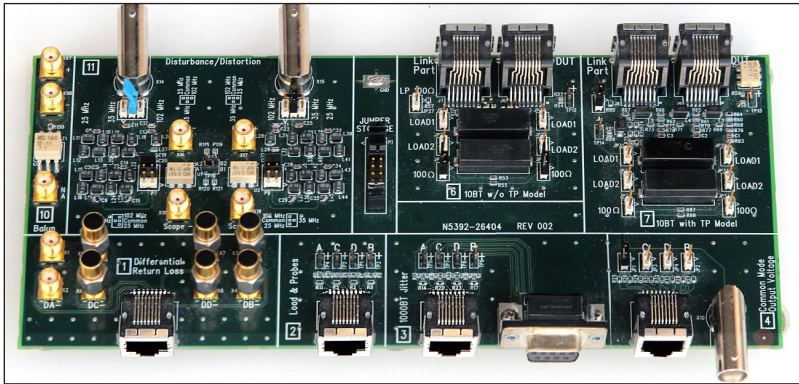

Figure 6. The Keysight N5395C fixture is optional when customers have RJ-45 cables coming from the device instead of SMA cables.

Test Name	Worst Actual	Worst Margin	Pass Limits
✗ Transmitter +Vout Droop	55.38 %	-23.1%	VALUE < 45.00 %
✗ Transmitter -Vout Droop	55.23 %	-22.7%	VALUE < 45.00 %
✓ TX_TCLK Frequency (Master)	66.669190 MHz	31.1%	66.660000 MHz <= VALUE <= 66.673333 MHz
✓ MDI Output Jitter, JTXOUT (Master)	23.293 ps	53.4%	VALUE < 50.000 ps
ⓘ TX_TCLK Frequency (Slave)	66.669150 MHz		Information Only
✓ TX_TCLK Jitter (Slave)	1.449 mUI	85.5%	VALUE < 10.000 mUI
✗ Transmitter Distortion	19.35 mV	-23.0%	VALUE <= 15.00 mV
✗ Transmitter Power Spectral Density	-46.412 dBm/Hz	-464.1%	Overall = Pass

Figure 7. The BroadR-Reach electrical test software results screen shows a summary of the tests performed, pass/fail status, and margin. Clicking on a specific test also shows the test specification and a measurement waveform, if appropriate.

## Reports with margin analysis

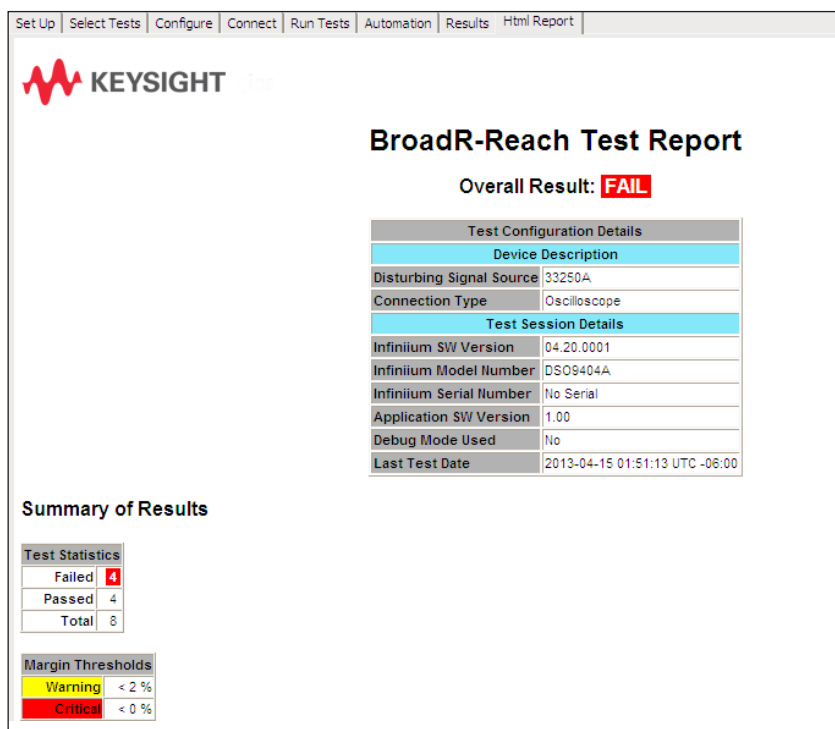

Figure 8. The BroadR-Reach electrical test software HTML report documents your test and indicates the pass/fail status, test specification range, measured values, and margin.

## Reports with margin analysis

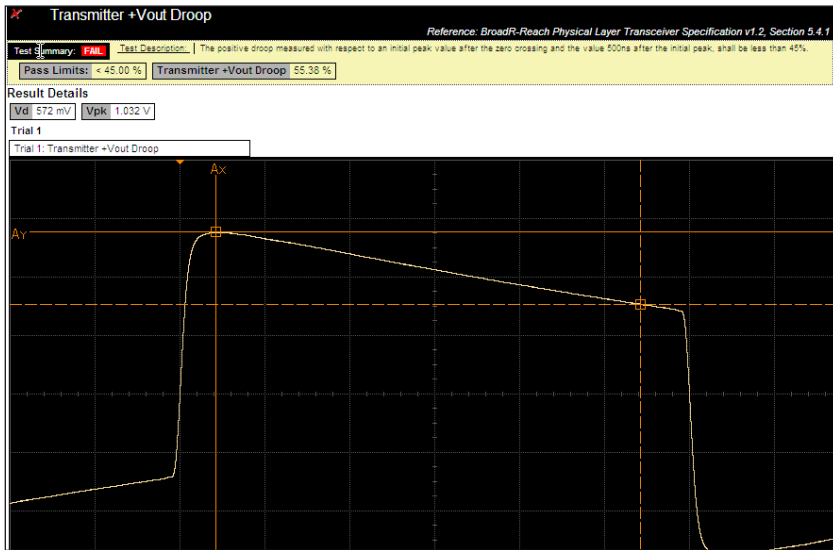

Figure 9. Additional details are available for each test, including the test limits, test description, and test results, including waveforms, if appropriate.

Summary of Results						
<b>Test Statistics</b>						
Failed	4					
Passed	4					
Total	8					
<b>Margin Thresholds</b>						
Warning	< 2 %					
Critical	< 0 %					
Pass	# Failed	# Trials	Test Name	Worst Actual	Worst Margin	Pass Limits
✘	1	1	Transmitter +Vout Droop	55.38 %	-23.1 %	VALUE < 45.00 %
✘	1	1	Transmitter -Vout Droop	55.23 %	-22.7 %	VALUE < 45.00 %
✔	0	1	TX_TCLK Frequency (Master)	66.669190 MHz	31.1 %	66.660000 MHz <= VALUE <= 66.673333 MHz
✔	0	1	MDI Output Jitter, JTXOUT (Master)	23.293 ps	53.4 %	VALUE < 50.000 ps
ℹ	0	1	TX_TCLK Frequency (Slave)	66.669150 MHz		Information Only
✔	0	1	TX_TCLK Jitter (Slave)	1.449 mUI	85.5 %	VALUE < 10.000 mUI
✘	1	1	Transmitter Distortion	19.35 mV	-29.0 %	VALUE <= 15.00 mV
✘	2	2	Transmitter Power Spectral Density	-46.412 dBm/Hz	-464.1 %	Overall = Pass

Figure 10. How close your device comes to passing or failing a test is indicated as a percentage in the margin field. A result highlighted in yellow or red indicates that your device has tripped the margin threshold level for a warning or failure.



## Extensibility

You may add additional custom tests or steps to your application using the N5467A User Defined Application (UDA) development tool ([www.keysight.com/find/uda](http://www.keysight.com/find/uda)). Use UDA to develop functional “Add-Ins” that you can plug into your application.:

Add-Ins may be designed as:

- Complete custom tests (with configuration variables and connection prompts)
- Any custom steps such as pre or post processing scripts, external instrument control and your own device control

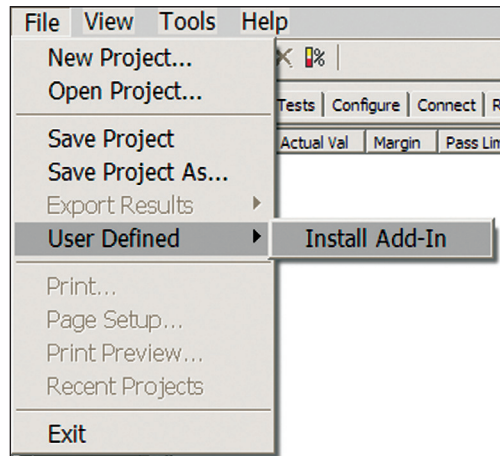

Figure 11. Importing a UDA Add-In into your test application.

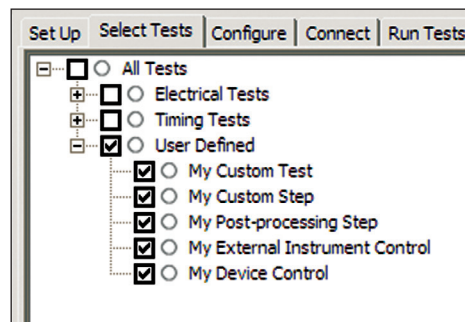

Figure 12. UDA Add-In tests and utilities in your test application.

## Automation

You can completely automate execution of your application's tests and Add-Ins from a separate PC using the included N5452A Remote Interface feature (download free toolkit from [www.keysight.com/find/scope-apps-sw](http://www.keysight.com/find/scope-apps-sw)). You can even create and execute automation scripts right inside the application using a convenient built-in client.

The commands required for each task may be created using a command wizard or from "remote hints" accessible throughout the user interface.

Using automation, you can accelerate complex testing scenarios and even automate manual tasks such as:

- Opening projects, executing tests and saving results
- Executing tests repeatedly while changing configurations
- Sending commands to external instruments
- Executing tests out of order

Combine the power of built-in automation and extensibility to transform your application into a complete test suite executive:

- Interact with your device controller to place it into desired states or test modes before test execution.
- Configure additional instruments used in your test suite such as a pattern generator and probe switch matrix.
- Export data generated by your tests and post-process it using your favorite environment, such as MATLAB, Python, LabVIEW, C, C++, Visual Basic, etc.
- Sequence or repeat the tests and "Add-In" custom steps execution in any order for complete test coverage of the test plan.

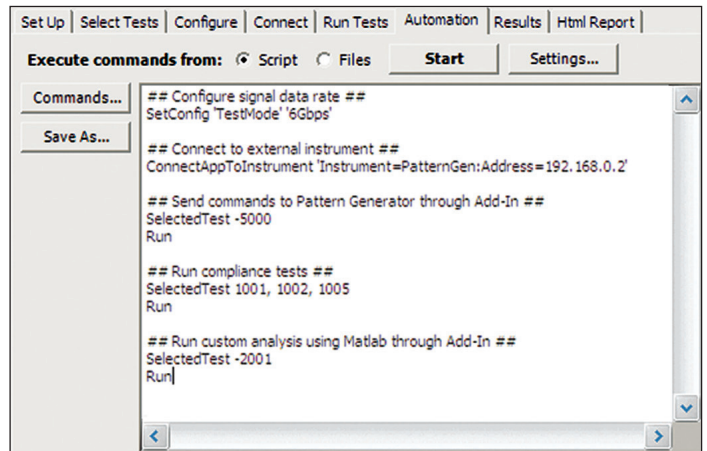

Figure 13. Remote Programming script in the Automation tab.

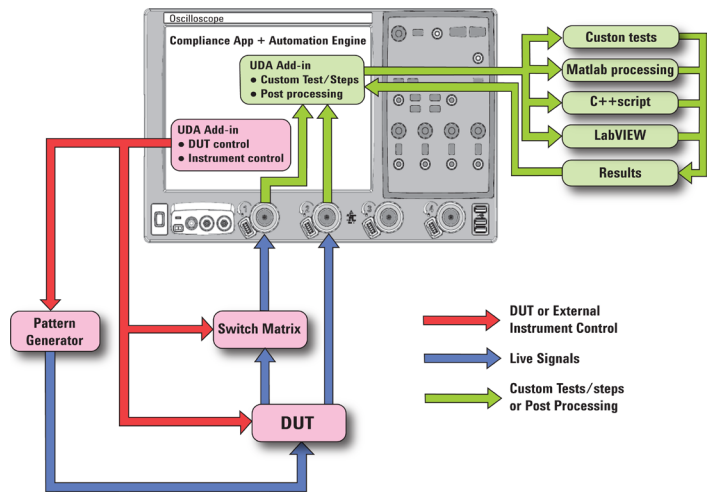

Figure 14. Combine the power of built-in automation and extensibility to transform your application into a complete test suite executive.

The N6467A BroadR-Reach automotive compliance application covers all of the following BroadR-Reach physical layer transceiver specification tests.

Table 2. BroadR-Reach electrical tests performed by the N6467A compliance application software

<b>BroadR-Reach physical layer transceiver specification for automotive applications tests</b>	<b>Description</b>
5.4.1	Transmitter output positive droop
5.4.1	Transmitter output negative droop
5.4.2	Transmitter distortion
5.4.3	Transmitter master timing jitter
5.4.3	Transmitter slave timing jitter
5.4.4	Transmitter Power Spectral Density (PSD) with spectral analyzer
5.4.4	Transmitter Power Spectral Density (PSD) with oscilloscope
5.4.5	Transmit clock frequency (master)
5.4.5	Transmit clock frequency (slave)

## Measurement requirements

To use the N6467A BroadR-Reach electrical performance validation and conformance software on your Infiniium oscilloscope, you will need SMA cables to connect the device to the oscilloscope.

The following section describes the fixtures and tests.

## Keysight N5395C electrical conformance test fixture

The optional Keysight N5395C electrical conformance test fixture allows for certain automotive devices to connect to the oscilloscope through an RJ-45 cable.

## Ordering information

### Recommended oscilloscopes

The BroadR-Reach compliance software is compatible with Keysight Infiniium Series oscilloscopes with operating software revision 4.20 or higher. For oscilloscopes with earlier revisions, free upgrade software is available here: [www.keysight.com/find/scope-apps-sw](http://www.keysight.com/find/scope-apps-sw)

Standard	Data rate	Minimum bandwidth	Minimum channels	Oscilloscope models
BroadR-Reach	100 Mb/s	600 MHz	2	Infiniium 9000, S-Series, 90000 and Z-Series

### Recommended probe

Standard	Data rate	Recommended probes	Minimum probe bandwidth
BroadR-Reach	100 Mb/s	113xA or 116XA or N275xA Series	1.5 GHz

### Recommended probe heads

Model number	Description
E2678A	InfiniiMax socketed differential probe head
E2677A	InfiniiMax solder-in differential probe head
N5381A	InfiniiMax solder-in differential probe head
E2669A	InfiniiMax connectivity kit for differential/single-ended measurements (contains one E2575A differential browser probe head, four E2677A solder-in differential probe heads, and two E2678A socketed differential probe heads) <sup>1</sup>

1. An alternative to purchasing the E2677A and E2678A is the E2669A.

### Recommended fixture

Part number	Compliance testing	Description
N5395C	10/100/1000 Ethernet	Keysight Ethernet electrical compliance test fixture kit <sup>2</sup>

2. The N5395C Ethernet electrical compliance test fixture kit includes a main test board, Ethernet electrical compliance test board and two short RJ-45 Ethernet cables.

### Accessories

Model number	Description
SMA cables	2 maximum needed. Recommend two long (36") cables
Suggested vendor, part number: Farnell, 8558566 (36" length)	InfiniiMax solder-in differential probe head

## Ordering information (continued)

To purchase the BroadR-Reach software with a new or existing Infiniium Series oscilloscope, order the following options.

### Software options

Application	License type		Infiniium Z-Series	Infiniium S-Series	Infiniium 90000 Series	Infiniium 9000 Series
BroadR-Reach	Fixed	Factory-installed	N6467A-1FP	N6467B-1FP	Option 065	Option 065
		User-installed	N6467A-1FP	N6467B-1FP	N6467A-1NL	N6467B-1NL
	Floating	Transportable	N6467A-1TP	N6467B-1TP	N6467A-1TP <sup>1,2</sup>	N6467B-1TP <sup>1,2</sup>
		Server-based	N5435A-062			

1. Requires software 5.00 and above.

2. Software 4.30 or above requires Windows 7. N2753A Infiniium Windows XP to 7 OS upgrade kit (oscilloscope already has M890 motherboard). N2754A Infiniium Windows XP to 7 OS and M890 motherboard upgrade kit (oscilloscope without M890 motherboard). Verify the M890 motherboard using the procedure found in the Windows 7 upgrade kit data sheet, publication number 5990-8569EN.

## Related Keysight literature

Publication title	Pub number
<i>Infiniium 90000 Series Oscilloscopes Data Sheet</i>	5989-7819EN
<i>N5435A Infiniium Server-Based License for Infiniium Oscilloscopes Data Sheet</i>	5989-6937EN
<i>E2688A, N5384A High-Speed Serial Data Analysis and Clock Recovery Software for Infiniium Oscilloscopes Data Sheet</i>	5989-0108EN
<i>Infiniium 9000 Series Oscilloscopes Data Sheet</i>	5990-3746EN
<i>Infiniium 90000 X-Series Oscilloscopes Data Sheet</i>	5990-5271EN

**myKeysight**

**myKeysight**

[www.keysight.com/find/mykeysight](http://www.keysight.com/find/mykeysight)

A personalized view into the information most relevant to you.



[www.axiestandard.org](http://www.axiestandard.org)

AdvancedTCA® Extensions for Instrumentation and Test (AXIe) is an open standard that extends the AdvancedTCA for general purpose and semiconductor test. Keysight is a founding member of the AXIe consortium. ATCA®, AdvancedTCA®, and the ATCA logo are registered US trademarks of the PCI Industrial Computer Manufacturers Group.



[www.lxistandard.org](http://www.lxistandard.org)

LAN eXtensions for Instruments puts the power of Ethernet and the Web inside your test systems. Keysight is a founding member of the LXI consortium.



[www.pxisa.org](http://www.pxisa.org)

PCI eXtensions for Instrumentation (PXI) modular instrumentation delivers a rugged, PC-based high-performance measurement and automation system.



**Three-Year Warranty**

[www.keysight.com/find/ThreeYearWarranty](http://www.keysight.com/find/ThreeYearWarranty)

Keysight's commitment to superior product quality and lower total cost of ownership. The only test and measurement company with three-year warranty standard on all instruments, worldwide.



**Keysight Assurance Plans**

[www.keysight.com/find/AssurancePlans](http://www.keysight.com/find/AssurancePlans)

Up to five years of protection and no budgetary surprises to ensure your instruments are operating to specification so you can rely on accurate measurements.



[www.keysight.com/quality](http://www.keysight.com/quality)

Keysight Technologies, Inc.  
DEKRA Certified ISO 9001:2008  
Quality Management System

**Keysight Channel Partners**

[www.keysight.com/find/channelpartners](http://www.keysight.com/find/channelpartners)

Get the best of both worlds: Keysight's measurement expertise and product breadth, combined with channel partner convenience.

[www.keysight.com/find/BroadR-Reach](http://www.keysight.com/find/BroadR-Reach)

For more information on Keysight Technologies' products, applications or services, please contact your local Keysight office. The complete list is available at: [www.keysight.com/find/contactus](http://www.keysight.com/find/contactus)

**Americas**

Canada	(877) 894 4414
Brazil	55 11 3351 7010
Mexico	001 800 254 2440
United States	(800) 829 4444

**Asia Pacific**

Australia	1 800 629 485
China	800 810 0189
Hong Kong	800 938 693
India	1 800 112 929
Japan	0120 (421) 345
Korea	080 769 0800
Malaysia	1 800 888 848
Singapore	1 800 375 8100
Taiwan	0800 047 866
Other AP Countries	(65) 6375 8100

**Europe & Middle East**

Austria	0800 001122
Belgium	0800 58580
Finland	0800 523252
France	0805 980333
Germany	0800 6270999
Ireland	1800 832700
Israel	1 809 343051
Italy	800 599100
Luxembourg	+32 800 58580
Netherlands	0800 0233200
Russia	8800 5009286
Spain	800 000154
Sweden	0200 882255
Switzerland	0800 805353
	Opt. 1 (DE)
	Opt. 2 (FR)
	Opt. 3 (IT)
United Kingdom	0800 0260637

For other unlisted countries:  
[www.keysight.com/find/contactus](http://www.keysight.com/find/contactus)  
(BP-09-23-14)

