

User's Guide (Abridged)

## Keysight B-Series FieldFox Analyzers

This manual provides documentation for the following models:

N9913B, N9914B, N9915B, N9916B, N9917B, N9918B  
N9933B, N9934B, N9935B, N9936B, N9937B, N9938B  
N9950B, N9951B, N9952B, N9953B  
N9960B, N9961B, N9962B, N9963B

This B Series User's Guide, p/n N9938-90003, is an abridged version of the User's Guide, p/n N9938-90006. Some cross-references in this abridged version refer to chapters and sections in the unabridged User's Guide that can be found here:

<https://www.keysight.com/us/en/assets/9921-01763/user-manuals/Users-Guide-B-Series-N991xB-3xB-5xB-6xB-Unabridged.pdf>



# Notices

© Keysight Technologies, Inc.  
2014-2021

No part of this manual may be reproduced in any form or by any means (including electronic storage and retrieval or translation into a foreign language) without prior agreement and written consent from Keysight Technologies, Inc. as governed by United States and international copyright laws.

## Trademark Acknowledgments

*Bluetooth®*

## Manual Part Number

N9938-90003

## Edition

Edition 4, December 2021

Printed in USA/Malaysia

Published by:  
Keysight Technologies  
1400 Fountaingrove Parkway  
Santa Rosa, CA 95403

## Warranty

THE MATERIAL CONTAINED IN THIS DOCUMENT IS PROVIDED "AS IS," AND IS SUBJECT TO BEING CHANGED, WITHOUT NOTICE, IN FUTURE EDITIONS. FURTHER, TO THE MAXIMUM EXTENT PERMITTED BY APPLICABLE LAW, KEYSIGHT DISCLAIMS ALL WARRANTIES, EITHER EXPRESS OR IMPLIED WITH REGARD TO THIS MANUAL AND ANY INFORMATION CONTAINED HEREIN, INCLUDING BUT NOT LIMITED TO THE IMPLIED WARRANTIES OF MERCHANTABILITY AND FITNESS FOR A PARTICULAR PURPOSE. KEYSIGHT SHALL NOT BE LIABLE FOR ERRORS OR FOR INCIDENTAL OR CONSEQUENTIAL DAMAGES IN CONNECTION WITH THE FURNISHING, USE, OR PERFORMANCE OF THIS DOCUMENT OR ANY INFORMATION CONTAINED HEREIN. SHOULD KEYSIGHT AND THE USER HAVE A SEPARATE WRITTEN AGREEMENT WITH WARRANTY TERMS COVERING THE MATERIAL IN THIS

DOCUMENT THAT CONFLICT WITH THESE TERMS, THE WARRANTY TERMS IN THE SEPARATE AGREEMENT WILL CONTROL.

## Technology Licenses

The hardware and/or software described in this document are furnished under a license and may be used or copied only in accordance with the terms of such license.

## U.S. Government Rights

The Software is "commercial computer software," as defined by Federal Acquisition Regulation ("FAR") 2.101. Pursuant to FAR 12.212 and 27.405-3 and Department of Defense FAR Supplement ("DFARS") 227.7202, the U.S. government acquires commercial computer software under the same terms by which the software is customarily provided to the public. Accordingly, Keysight provides the Software to U.S. government customers under its standard commercial license, which is embodied in its End User License Agreement (EULA), a copy of which can be found at

<http://www.keysight.com/find/sweula>. The license set forth in the EULA represents the exclusive authority by which the U.S. government may use, modify, distribute, or disclose the Software. The EULA and the license set forth therein, does not require or permit, among other things, that Keysight: (1) Furnish technical information related to commercial computer software or commercial computer software documentation that is not customarily provided to the public; or (2) Relinquish to, or otherwise provide, the government rights in excess of these rights customarily provided to the public to use, modify, reproduce, release, perform, display, or disclose commercial computer software or commercial computer software documentation. No additional government requirements beyond those set forth in the EULA shall apply, except to the extent that those terms, rights, or licenses are explicitly required from all providers of commercial computer software pursuant to the FAR and the DFARS and are set forth specifically in

writing elsewhere in the EULA. Keysight shall be under no obligation to update, revise or otherwise modify the Software. With respect to any technical data as defined by FAR 2.101, pursuant to FAR 12.211 and 27.404.2 and DFARS 227.7102, the U.S. government acquires no greater than Limited Rights as defined in FAR 27.401 or DFAR 227.7103-5 (c), as applicable in any technical data.

## Safety Notices

### CAUTION

A **CAUTION** notice denotes a hazard. It calls attention to an operating procedure, practice, or the like that, if not correctly performed or adhered to, could result in damage to the product or loss of important data. Do not proceed beyond a CAUTION notice until the indicated conditions are fully understood and met.

### WARNING

A **WARNING** notice denotes a hazard. It calls attention to an operating procedure, practice, or the like that, if not correctly performed or adhered to, could result in personal injury or death. Do not proceed beyond a WARNING notice until the indicated conditions are fully understood and met.

### NOTE

A **NOTE** calls the user's attention to an important point or special information in the text.

## Where to Find the Latest Information

Documentation is updated periodically. For the latest information about these products, including instrument software upgrades, application information, and product information, browse to one of the following URLs, according to the name of your product:

<http://www.keysight.com/find/fieldfox>

To receive the latest updates by email, subscribe to Keysight Email Updates at the following URL:

<http://www.keysight.com/find/MyKeysight>

Information on preventing instrument damage can be found at:

[www.keysight.com/find/PreventingInstrumentRepair](http://www.keysight.com/find/PreventingInstrumentRepair)

## Is your product software up-to-date?

Periodically, Keysight releases software updates to fix known defects and incorporate product enhancements. To search for software updates for your product, go to the Keysight Technical Support website at:

<http://www.keysight.com/find/fieldfoxsupport>

## A.12.3x Firmware – Release B Series FieldFox

For customers upgrading FieldFox firmware, the following is a list of changes from the previous release:

- Added: EMI (Electromagnetic Interference) – Option 361 Measurement mode
  - CISPR (International Special Committee on Radio Interference) and Amplitude Probability
- SA mode – Added:
  - IQ Streaming (Option 353)
  - EMI Electromagnetic Interference (Option 361)
  - EIRP (Effective Isotropic Radiated Power)
  - Analog Demodulation Metrics
- Mapping functionality – Added: Directional Bearing

## Contacting Keysight

Assistance with test and measurements needs and information on finding a local Keysight office are available on the Web at: <http://www.keysight.com/find/assist>.

If you do not have access to the Internet, please contact your Keysight field engineer.

In any correspondence or telephone conversation, refer to the Keysight product by its model number and full serial number. With this information, the Keysight representative can determine whether your product is still within its warranty period.

To contact Keysight for sales and technical support, refer to support links on the following Keysight websites: <http://www.keysight.com/find> (product specific information and support, software and documentation updates) <http://www.keysight.com/find/assist> (worldwide contact information for repair and service).



<b>1. Overview</b>	
Models and Options . . . . .	25
Accessories . . . . .	26
Optional Accessories . . . . .	26
FieldFox Manuals, Software, and Supplemental Help . . . . .	27
Conventions that are used in the Manual . . . . .	27
Safety Notes . . . . .	27
<b>2. Preparing for Initial Use of Your New FieldFox</b>	
Check the Shipment . . . . .	29
Meeting Power Requirements for the AC/DC Adapter . . . . .	29
Install the Lithium-Ion Battery . . . . .	30
Battery Usage . . . . .	30
FieldFox ON/OFF Settings . . . . .	31
Power Button LED Status . . . . .	32
FieldFox High Temperature Protection . . . . .	32
How to monitor the internal FieldFox temperature: . . . . .	32
Temperature Control Mode . . . . .	33
High-Temp Shutdown Warning (RTSA Mode Only) . . . . .	35
Avoid Overpowering the FieldFox . . . . .	36
Take the FieldFox Tour . . . . .	38
Front Panel . . . . .	38
Top Panel . . . . .	41
Right Side Panel . . . . .	42
Left Side Panel . . . . .	43
Screen Tour . . . . .	44
How to Enter Numeric Values . . . . .	46
Multiplier Abbreviations . . . . .	46
Connector Care . . . . .	47
<b>3. CAT (Cable and Antenna Test) Mode</b>	
CAT Mode Settings . . . . .	51
How to select CAT Mode . . . . .	51
Measurement Selection . . . . .	51
Quick Settings Table . . . . .	52
Frequency Range . . . . .	53
Scale Settings . . . . .	53
Averaging . . . . .	54
Smoothing . . . . .	55
Single or Continuous Measure . . . . .	55
Resolution (Number of Data Points) . . . . .	56

Sweep Time . . . . .	56
Output Power . . . . .	57
Interference Rejection . . . . .	58
Coupled Frequency . . . . .	58
Return Loss Measurements . . . . .	60
How to Measure Return Loss . . . . .	60
1-Port Cable Loss Measurements . . . . .	60
How to make a 1-port Cable Loss Measurement . . . . .	61
2-Port Insertion Loss Measurements . . . . .	62
<b>4. DTF (Distance to Fault) Measurements</b>	
How to make DTF Measurements . . . . .	64
DTF Measurement Settings . . . . .	66
DTF Settings Table . . . . .	66
DTF Measurement (Format) . . . . .	66
DTF Start and Stop Distance . . . . .	67
Frequency Mode . . . . .	67
Coupled Frequency . . . . .	68
Cable (Correction) Specifications . . . . .	69
Window Settings . . . . .	72
DTF Units . . . . .	73
Calculated DTF values . . . . .	73
About Alias Faults . . . . .	73
<b>5. TDR (Time Domain Reflectometry) - Option 215</b>	
TDR Measurement Settings . . . . .	78
TDR Measurement (Format) . . . . .	78
TDR Settings Table . . . . .	78
TDR Start and Stop Distance . . . . .	79
TDR Sweep . . . . .	79
Frequency Mode . . . . .	80
Cable (Correction) Specifications . . . . .	81
Window Settings . . . . .	84
TDR Units . . . . .	85
Calculated TDR values . . . . .	85
About Alias Faults . . . . .	86
How to Prevent Undersampling . . . . .	87
<b>6. NA (Network Analyzer) Mode</b>	
NA Mode Settings . . . . .	91
About S-parameters . . . . .	91
Mixed-Mode S-Parameters . . . . .	92

Parameter Conversion . . . . .	93
Receiver Measurements . . . . .	94
Multi-Trace Configurations . . . . .	95
Quick Settings . . . . .	96
Calibration Settings . . . . .	97
Format . . . . .	98
Frequency Range . . . . .	99
Scale Settings. . . . .	99
Magnitude Offset . . . . .	100
Electrical Delay . . . . .	101
Phase Offset . . . . .	101
Averaging . . . . .	102
IF Bandwidth. . . . .	103
Smoothing . . . . .	103
Single or Continuous Measure. . . . .	104
Resolution (Number of Data Points) . . . . .	104
Sweep Time . . . . .	105
Triggering . . . . .	105
Output Power . . . . .	107
System Impedance (Z0) . . . . .	108
Port Extensions. . . . .	108
Velocity Factor . . . . .	109
Big Marker Display States (A and B) . . . . .	110
Increase Dynamic Range . . . . .	112

**7. Time Domain – Option 010**

Overview . . . . .	115
Time Domain (Transform) Settings . . . . .	116
Transform Settings Table . . . . .	116
Start/Stop (Frequency Range) and Points. . . . .	116
Stimulus (Mode) . . . . .	117
Set Frequency Lowpass . . . . .	117
Start/Stop Time . . . . .	117
Distance Units . . . . .	118
Window Layout. . . . .	118
Transform Window . . . . .	118
Line Loss and Velocity Factor . . . . .	119
Data Chain . . . . .	120
Trace Settings. . . . .	121
Transform Enable . . . . .	121
Gate Enable . . . . .	121
Gating . . . . .	122

How to make Time Domain Gating settings . . . . .	123
Start, Stop, Center, and Span Gate Times . . . . .	123
Gating Type . . . . .	123
<b>8. Calibration for NA, CAT, and VVM Modes</b>	
. . . . .	126
Why and When to Calibrate . . . . .	126
Definitions . . . . .	126
CalReady . . . . .	127
How to Perform a Calibration . . . . .	127
Mechanical Cal . . . . .	129
ECal . . . . .	131
Simple Response Cals . . . . .	134
View Cal. . . . .	136
Calibration Type. . . . .	136
Isolation Step. . . . .	139
Waveguide Calibrations . . . . .	139
Enhanced Response Optimization . . . . .	141
Interpolation * . . . . .	142
Cal ON? – Questionable Accuracy . . . . .	142
Compatible Mode Calibrations . . . . .	142
Save the Calibration . . . . .	142
CalReady Properties . . . . .	142
Apply Nearest (NA Mode Only) . . . . .	144
Verifying Calibration and Jumper Cable Integrity. . . . .	144
Verify a Calibration . . . . .	144
Test the Jumper Cable . . . . .	145
Calibration Method Summary . . . . .	146
<b>9. SA (Spectrum Analyzer) Mode (Option 233–Mixed Analyzers)</b>	
SA Mode Settings . . . . .	151
How to select SA Mode. . . . .	151
Frequency Range. . . . .	151
Radio Standard . . . . .	153
Custom Radio Standards . . . . .	154
Channel Selection . . . . .	155
Reverse Swap . . . . .	156
Scale and Units . . . . .	157
External Gain . . . . .	158
Attenuation Control. . . . .	159
Preamplifier Control (Opt 235) . . . . .	160
Check for Compressed Measurements . . . . .	160

Field Strength Measurements . . . . .	161
Using the Antenna/Cable Editor . . . . .	163
Source Tracking Offset and Offset Reversal . . . . .	166
Tune & Listen (AM/FM). . . . .	166
Analog Demod . . . . .	170
Independent Source/Tracking Generator . . . . .	181
Resolution Bandwidth (Res BW) . . . . .	182
Video Bandwidth (Video BW). . . . .	183
AF RBW (Audio-Frequency Resolution BW) . . . . .	184
Sweep Type. . . . .	184
IF Output. . . . .	185
Sweep Acquisition . . . . .	188
Very Long Sweep Times . . . . .	190
Zero Span Measurements . . . . .	190
Triggering . . . . .	192
FFT Gating (Opt 238) . . . . .	196
Single / Continuous / Restart . . . . .	198
Points . . . . .	198
Trace Display States (SA Mode). . . . .	198
Average Type . . . . .	199
Average Count . . . . .	200
Alignments . . . . .	201
Detection Method. . . . .	208
Display Line . . . . .	210
Noise Marker . . . . .	211
Band/Interval Power Marker . . . . .	211
Frequency Counter at Marker . . . . .	212
Time Zero Fixed Marker . . . . .	213
Audio Beep at Marker Power . . . . .	213
Meas UNCAL Error . . . . .	214
Old Data Indicator (*) . . . . .	214
Channel Measurements . . . . .	215
Radio Standards and Channel Measurements . . . . .	215
Measurement Preset . . . . .	215
Averaging . . . . .	215
Traces . . . . .	216
Channel Power (CHP). . . . .	216
How to Set Up EMF Settings (Requires EMF (Option 358), GPS (Option 307), and SA Mode (Option 233–Mixed Analyzers)) . . . . .	226
EMF Features . . . . .	227
EMF Setup Procedure. . . . .	229
Spectrum Emission Mask (SEM) – (SA Mode Only) . . . . .	238

How to select Spectrum Emission Mask (SEM) Measurement . . . . .	240
IQ Analysis (Requires Option 351 IQ Analyzer and Option 353 IQ Streaming, SA Mode Only) . . . . .	245
How to Select IQ Analysis . . . . .	245
How to Setup IQ Analysis General . . . . .	246
How to Setup IQ Analysis Streaming . . . . .	246
Effective Isotropic Radiated Power (EIRP) – (SA Mode Only) . . . . .	248
How to Select Effective Isotropic Radiated Power (EIRP) . . . . .	248
How to Setup EIRP (Effective Isotropic Radiated Power) . . . . .	248

**10. RTSA (Real-time Spectrum Analyzer) Mode—Option 350**

RTSA Mode Settings . . . . .	254
How to select RTSA Mode . . . . .	254
Frequency Range . . . . .	254
Scale and Units . . . . .	255
External Gain . . . . .	256
Attenuation Control . . . . .	257
Preamplifier Control (Opt 235) . . . . .	258
Check for Compressed Measurements . . . . .	258
Spectrum Selection . . . . .	259
Setting the IF Path . . . . .	263
Resolution Bandwidth (Res BW) . . . . .	263
Triggering . . . . .	264
Single / Continuous / Restart / Time Per Div . . . . .	267
Acq Time . . . . .	268
Points (not user settable) . . . . .	268
Trace Display States (RTSA) . . . . .	269
Detection Method . . . . .	270
Average Count, Show Density, Blue, and Red Percentage Limits . . . . .	271
Alignments . . . . .	272
Display Line . . . . .	272
Spectrogram Display . . . . .	274
Spectrogram Display (RTSA Option) . . . . .	274
Common Settings for Spectrogram . . . . .	275
Record/Playback (RTSA Option) . . . . .	276
About Sessions . . . . .	276
FieldFox Setting Changes during Record and Playback . . . . .	277
About State and User Tags . . . . .	278
How to Record a Session . . . . .	279
How to Playback a Session . . . . .	280
Recording Configuration . . . . .	281
Record Source . . . . .	282

Playback Configuration . . . . .	283
Manage Sessions . . . . .	283
Record Playback Example (RTSA Mode Only) . . . . .	284
<b>11. IQ Analyzer (IQA) – Option 351</b>	
About I/Q Analyzer (IQA) Measurements . . . . .	289
I/Q Analyzer (IQA) Mode Settings . . . . .	290
How to Make Measurements Using the I/Q Analyzer Mode . . . . .	290
How to Capture I/Q Data to a File . . . . .	291
How to modify the I/Q data measurement parameters . . . . .	294
Using Markers (IQA) . . . . .	305
Noise Marker . . . . .	305
Band/Interval Power Marker . . . . .	306
Band Span Marker (Spectrum Only) . . . . .	307
Interval Span Marker (Waveform Only) . . . . .	307
Coupled Markers (Waveform Only) . . . . .	307
Continuous Peak Search Marker . . . . .	309
Alignments . . . . .	310
Trace Display States (IQA Mode) . . . . .	310
How to display the Trace States . . . . .	310
Other Features Available . . . . .	312
<b>12. Electromagnetic Interference (EMI) Measurements – Option 361</b>	
Using EMI Measurements (Option 361) . . . . .	317
EMI Measurements Mode Settings . . . . .	318
How to select EMI Measurements Mode . . . . .	318
Frequency Range . . . . .	318
Scale and Units . . . . .	320
External Gain . . . . .	320
Attenuation Control . . . . .	321
CISPR (International Special Committee on Radio Interference) Control . . . . .	321
Preamplifier Control (Opt 235) . . . . .	326
Independent Source/Tracking Generator . . . . .	326
. . . . .	326
Resolution Bandwidth (Res BW) . . . . .	326
Sweep Type . . . . .	327
Single / Continuous / Restart . . . . .	327
Points . . . . .	328
Trace Display States (EMI Mode) . . . . .	328
Average Type . . . . .	329
Average Count . . . . .	329

Alignments	329
Detection Method	330
Input – (Trace Input for APD Measurements)	331
About Electromagnetic Interference (EMI) Measurements	332
EMI Measurement Features (Option 361)	332
How to Set Up Electromagnetic Interference (EMI) Mode Settings	334
EMI Measurement Mode Setup Procedure	334
Glossary (EMI)	335

### 13. Over-the-Air Measurements (OTA) – LTE FDD Option 370, LTE TDD Option 371, 5G TF Option 377, 5G NR / 5G NR EVM Conducted Option 378

Using OTA (Options 370 – LTE FDD, 372 – TDD, 377 – 5G TF, and Option 378 – 5G NR / 5G NR Conducted)	340
About Over-the-Air (OTA) Measurements	342
LTE FDD and LTE TDD Features (Option 370 and Option 371)	342
5G TF Features (Option 377)	348
5G NR Features (Option 378)	349
5G NR EVM Conducted Features (P/O: Option 378)	352
How to Set Up Over-the-Air (OTA) Mode Settings	353
OTA Setup Procedure	353
Optional: Using RTSA to verify the signal quality (Requires Option 350 and Preamp Option 235)	370
How to Define a Cell or Cell(s) and Use OTA	371
How to Set Up EMF Mode Settings (Requires EMF (Option 358) and 5G NR (Option 378))	387
EMF Features	387
EMF Setup Procedure	390
How to Use Data Logging (OTA Options 370, 372, 377, and 378)	394
Screen Annotation	394
How to Record a Data Log Procedure	395
To change Data Logging Configuration settings:	396
How to Play a Data Log	397
Other Features Available	398
Troubleshooting	399
Glossary (OTA)	400

### 14. 5G Rapid Prototype Phased Array Antenna – Option 360

Using the Phased Array Antenna (Option 360)	407
About Phased Array Antenna Measurements	408
Phased Array Antenna Features (Option 360)	408
How to Set Up Phased Array Antenna Settings	417
Option 360 Setup Procedure	417

How to Define a Set Up a Scan and Use Option 360 .....	429
How to Use Data Logging/Playback (Option 360) .....	438
Screen Annotation .....	438
How to Record a Data Log .....	440
To change Data Logging Configuration settings: .....	440
How to Playback a Data Log .....	441
Using Mapping .....	442
Other Features Available .....	442
Troubleshooting .....	443
<b>15. USB Antennas – (Full Capability Requires EMF Option 358, and either SA mode (Option 233 Mixed Analyzers) or OTA–5G NR / 5G NR EVM Conducted Option 378)</b>	
Using USB Antennas .....	448
About USB Antenna Measurements .....	449
USB Antenna Features .....	449
How to Set Up a USB Antenna .....	451
USB Antenna Setup Procedure .....	451
Other Features Available .....	455
Troubleshooting .....	456
<b>16. Indoor and Outdoor Mapping – Option 352 (Requires Spectrum Analyzer Mode (Option 233), and GPS Receiver (Option 307))</b>	
How to Install Node.js and Running the FieldFox Mapping Software .....	462
Downloading and Using the FieldFox Map Support Tool .....	464
Importing a .zip File to the FieldFox .....	469
How to Set Up Mapping Settings .....	471
How to Set Up Mapping When the FieldFox Is On The LAN .....	472
Option 352 Indoor Maps Setup Procedure .....	474
Option 352 Outdoor Maps Setup Procedure .....	478
Setting up Data Logging .....	486
How to Use Data Logging (Option 352) .....	494
Screen Annotation .....	494
How to Add Directional Finding (DF) Bearing .....	496
How to Record a Data Log (Outdoor Logging Only) .....	499
To change Data Logging Configuration settings: .....	500
How to Play a Data Log .....	500
Troubleshooting .....	501
General Troubleshooting .....	503
Port 5000 in Use Error .....	503
Update Available Message .....	505
Miscellaneous Mapping Errors .....	506

<b>17. Remote Server Mode (Requires SA Hardware/SA Option 233)</b>	
In this Chapter: . . . . .	508
Connecting Using Remote Server . . . . .	509
Changing Frequency Converter Head Settings . . . . .	510
89600 VSA Software Overview (Requires N991xB/3xB/5xB/6xB and SA Option 233) . . . . .	511
<b>18. Interference Analyzer (SA Mode) – Option 236</b>	
Spectrogram and Waterfall Displays. . . . .	514
Spectrogram Display (SA Option) . . . . .	514
Common Settings for Waterfall and Spectrogram . . . . .	516
Waterfall Display . . . . .	517
Record/Playback (SA Option) . . . . .	519
About Sessions . . . . .	519
FieldFox Setting Changes during Record and Playback . . . . .	520
About State and User Tags . . . . .	521
How to Record a Session . . . . .	522
How to Playback a Session . . . . .	523
Recording Configuration . . . . .	523
Frequency Mask Trigger Configuration (SA Mode Only) . . . . .	525
Record Source . . . . .	526
Playback Configuration . . . . .	527
Manage Sessions. . . . .	527
Record Playback Example (SA Only). . . . .	528
<b>19. Reflection Mode (SA Models) – Option 320</b>	
Reflection Mode Settings . . . . .	534
How to select Reflection Mode . . . . .	534
Measurement Selection. . . . .	534
Normalize. . . . .	534
<b>20. Built-in Power Meter Mode – Option 310</b>	
Built-in Power Meter Settings. . . . .	539
How to select Built-in Power Meter Mode . . . . .	539
Frequency/ Span / Step . . . . .	539
Attenuation . . . . .	540
<b>21. Power Meter (USB/LAN) Mode – Option 302</b>	
. . . . .	543
Supported Power Sensors. . . . .	543
How to Connect a USB Power Sensor . . . . .	543
How to Connect a LAN Power Sensor . . . . .	544
USB and LAN Power Meter Settings. . . . .	546

How to select Power Meter Mode . . . . .	546
How to select a Sensor Type . . . . .	546
Average / Peak . . . . .	546
Zeroing . . . . .	547
Frequency . . . . .	547
Source Control . . . . .	548
Source Power Measurements . . . . .	549
Relative and Offset Power Measurements . . . . .	550
Display Units . . . . .	550
Resolution . . . . .	551
Averaging . . . . .	551
Single or Continuous Measure . . . . .	551
Step Detection Mode . . . . .	552
Limits . . . . .	552
Troubleshooting . . . . .	554
LAN Sensors . . . . .	554

## 22. Frequency Offset Using Power Sensor (FOPS) – Option 208

Overview . . . . .	559
FOPS Settings . . . . .	561
How to select Power Meter (USB Sensor) . . . . .	561
Measurement Selection . . . . .	561
Sweep Type and Frequency . . . . .	562
Power Sensor Settling . . . . .	564
Sweep Settings . . . . .	564
Amplitude Markers . . . . .	565
Trace Math . . . . .	565

## 23. Pulse Measurements Mode – Option 330

Supported Power Sensors . . . . .	569
Switching between Pulse Measurement Mode and Power Meter Mode . . . . .	569
How to Connect the USB Power Sensor . . . . .	570
How to Connect the LAN Power Sensor . . . . .	570
Pulse Measurement Settings . . . . .	573
How to select Pulse Measurement Mode . . . . .	573
Measurement Selection . . . . .	573
Frequency / Time . . . . .	573
Zoom Window . . . . .	574
Scale . . . . .	575
Averaging . . . . .	575
Video Bandwidth . . . . .	576
Single or Continuous Measure . . . . .	577

Resolution . . . . .	577
Triggering . . . . .	577
Marker Settings . . . . .	580
Amplitude Markers . . . . .	581
Marker Search . . . . .	581
Auto Analysis . . . . .	582
Pulse Top . . . . .	583
Grid . . . . .	583
Trace Memory . . . . .	584

#### 24. VVM (Vector Voltmeter) Mode - Option 308

Overview . . . . .	587
VVM Mode Settings . . . . .	588
How to select VVM Mode . . . . .	588
Measurement Selection . . . . .	588
Frequency Selection . . . . .	588
Display Resolution . . . . .	588
IF Bandwidth . . . . .	589
Output Power . . . . .	589
AveragingS . . . . .	590
Single or Continuous Measure . . . . .	591
VVM Calibration . . . . .	591
Zeroing . . . . .	591
1-Port Cable Trimming Measurements . . . . .	593
How to make a 1-Port Cable Trimming Measurement . . . . .	593
2-Port Transmission Measurements . . . . .	595
How to make a 2-Port Transmission Measurement . . . . .	595
A/B and B/A Measurements . . . . .	596

#### 25. ERTA (Extended Range Transmission Analysis) Mode - Option 209

Overview . . . . .	598
Requirements and Limitations . . . . .	599
Requirements . . . . .	599
Limitations . . . . .	599
Start Connection Wizard . . . . .	600
On the Receiver unit: . . . . .	600
Configure Measurement Settings . . . . .	604
Select Measurement . . . . .	604
Normalize . . . . .	605
Source Tracking Offset and Offset Reversal . . . . .	605
Improve Dynamic Range . . . . .	606

Source Enable and Source Mode . . . . .	606
<b>26. AM/FM Metrics (SA Only and Option 355)</b>	
Using AM/FM Metrics . . . . .	607
Overview of Measurement Types . . . . .	607
How to Set Up AM/FM Metrics . . . . .	610
SINAD and THD Calculations . . . . .	614
Interpreting AM/FM Metrics Error Messages . . . . .	617
Test Tone Not Found . . . . .	617
<b>27. Channel Scanner (Option 312)</b>	
Using Channel Scanner . . . . .	622
How to Set Up Channel Scanner . . . . .	623
How to Define a Channel and Use Channel Scanner . . . . .	626
Field Strength Measurements . . . . .	640
Using the Antenna/Cable Editor . . . . .	646
Using Mapping . . . . .	648
Using Resolution Bandwidth Tradeoff (Res BW Tradeoff) . . . . .	648
<b>28. Noise Figure Mode (Option 356)</b>	
Using Noise Figure . . . . .	652
How to Define a Noise Figure Measurement . . . . .	656
Example: Typical Noise Figure Measurement Procedure . . . . .	656
Overview of Softkey Menus . . . . .	657
How to Use DUT Measurement Setups . . . . .	664
Single / Continuous / Restart . . . . .	676
Points . . . . .	676
Resolution Bandwidth (Res BW) . . . . .	677
Alignments . . . . .	677
Calculating Noise Figure Measurement Uncertainty . . . . .	678
Using ENR Tables . . . . .	683
About ENR (*.enr), Preamplifier (*.amp), and DUT (*.dut) Files . . . . .	684
Using Markers (Noise Figure) . . . . .	686
Calibration Wizard . . . . .	687
When to Calibrate . . . . .	687
How to use Auto-Integration . . . . .	690
About Auto-Integration . . . . .	690
Auto-Integration Procedure . . . . .	691
Other Features Available . . . . .	696
Troubleshooting . . . . .	697

## 29. Data Analysis Features

All about Markers . . . . .	700
How to create Markers . . . . .	700
How to move a Marker after it is created . . . . .	700
About Delta Markers . . . . .	701
Signal Track Marker (NF and SA Mode ONLY) . . . . .	702
Marker Table . . . . .	702
Coupled Markers (NA Mode) . . . . .	703
Marker Colors . . . . .	704
Marker Trace (CAT, NA, NF Modes) . . . . .	704
Marker Trace (IQA and SA Mode) . . . . .	704
Marker Format . . . . .	705
Searching with Markers . . . . .	706
What Is a 'Peak' . . . . .	711
Marker Functions . . . . .	713
I/Q Analyzer (IQA) Marker Functions . . . . .	714
SA Marker Functions . . . . .	714
All about Limit Lines . . . . .	715
How to Create Fixed Limit Lines . . . . .	715
Relative Limit Lines . . . . .	716
Build From Trace . . . . .	716
Limit Options . . . . .	717
How to Save and Recall Limits . . . . .	718
Display Line (I/Q, NF, and SA Modes Only) . . . . .	719
All about Trace Math . . . . .	720
How to display data and memory traces . . . . .	720
How to perform Trace Math . . . . .	720
About Math Operations . . . . .	721
All about Scale Settings . . . . .	722
How to Use Scale Settings . . . . .	722
Averaging (CAT, NA, Power Meter, Channel Scanner, and Pulse Measurement Modes Only)	722

## 30. System Settings

Run/Hold . . . . .	726
How to perform a single sweep while in Hold . . . . .	726
Preset . . . . .	727
How to Preset the FieldFox . . . . .	727
User Preset . . . . .	727
How to set User Preset . . . . .	728
How to recall User Preset . . . . .	728

Audio (Volume) Control . . . . .	728
How to set the FieldFox Volume Control . . . . .	729
Display (Settings) . . . . .	729
Display Brightness . . . . .	729
Display Colors . . . . .	729
Trace Width . . . . .	730
Title . . . . .	730
Edit Keywords . . . . .	731
Full Screen Mode . . . . .	731
Utilities . . . . .	732
How to view and change Utilities Settings . . . . .	732
Preferences . . . . .	740
Quick Settings Table . . . . .	740
Save and Reset Preferences . . . . .	742
Global Settings (Overview) . . . . .	742
Display . . . . .	744
Audio . . . . .	745
Date and Time . . . . .	746
GPS . . . . .	746
How to select CAT distance units: . . . . .	746
Frequency Reference . . . . .	748
How to set the frequency reference settings: . . . . .	748
File folders . . . . .	748
How to set File Folders . . . . .	748
Alpha Numeric Editing . . . . .	749
File Saving Naming Options . . . . .	749
Quick Save Editing . . . . .	749
Group Save File Types Editing . . . . .	750
Group Save File Types Procedure . . . . .	750
Group Save File Types . . . . .	750
CAT (Distance Units) . . . . .	751
CAT/NA . . . . .	752
SA . . . . .	753
Discrete Colors Softkey Menu . . . . .	754
Using the Discrete Colors Softkey Menu . . . . .	754
System Configuration . . . . .	754
Options (Licensing) . . . . .	754
GNSS (GPS+) and GPS . . . . .	755
Frequency Reference Source . . . . .	760

Variable Voltage Source (Opt. 309) . . . . .	761
Security Level . . . . .	762
Date and Time, Format, and Time Zone Settings . . . . .	763
LAN Settings . . . . .	764
Power ON . . . . .	766
FieldFox Package Installer . . . . .	767
Service Diagnostics . . . . .	769
System Information . . . . .	769
Event Log . . . . .	769
Battery . . . . .	769
Internal Temperatures . . . . .	769
Erase User Data . . . . .	769
How to Erase User Data . . . . .	770
Understanding the Fan Controls . . . . .	771
<b>31. Using the Mini-USB Port to send SCPI Commands and Queries</b>	
Mini-USB Connection to PC with IO Libraries . . . . .	775
<b>32. File Management</b>	
Saving and Recalling Files . . . . .	778
Save Files . . . . .	778
Recall Files . . . . .	782
Move (Copy) Files . . . . .	782
Set File Type and Select Device . . . . .	783
Manage Files . . . . .	786
Manage Folders . . . . .	788
Edit Keywords . . . . .	789
Prefixes and Suffixes for Filenames . . . . .	789
Press Printing . . . . .	792
How to print the current screen or a saved file . . . . .	792
<b>33. Working with the Lithium-Ion Battery</b>	
Viewing the Battery Charge Status . . . . .	793
Service Diagnostics–Battery Screen . . . . .	794
Built-In Battery Gauge . . . . .	794
Charging the Battery . . . . .	795
Internal Charging with the AC/DC Adapter . . . . .	795
Using the External Battery Charger (N9910X–872) . . . . .	797
Reconditioning Battery . . . . .	798
Battery Care . . . . .	798
Maximizing Battery Life . . . . .	798

Lithium-Ion Battery Disposal .....	799
<b>34. Safety Considerations</b>	
For the FieldFox .....	802
For the AC/DC Adapter .....	804
For the External Battery Charger (N9910X-872) .....	805
For the Battery .....	806
High Capacity Lithium Battery (N9910X-876) .....	807
Standard Capacity Battery (N9910X-870) .....	809
Battery Protective Functions .....	811
Battery Protective Functions (N9910X-876) .....	811
Battery Protective Functions (N9910X-870) .....	813
Batteries: Safe Handling and Disposal .....	814
Battery Transportation .....	814
Environmental Requirements .....	815
Electrical Requirements .....	815
Electrostatic Discharge (ESD) Precautions .....	815
FieldFox Markings .....	815
Battery Markings .....	818
Packaging Markings .....	821
AC/DC Adapter Markings .....	821
Certification and Compliance Statements .....	824
Certification .....	824
Manufacturer's Declaration .....	825
Declaration of Conformity .....	825
EMC .....	825
Safety .....	825
Acoustic Statement (European Machinery Directive) .....	825
<b>A:.Connector Care Review</b>	
.....	828
<b>B:.Specifications/Data Sheet</b>	
.....	830
<b>C:.Instrument Calibration</b>	
How Often Should Calibrate My Instrument? .....	831
How do I Get an Instrument Calibration? .....	831
What Are My Choices of Instrument Calibration? .....	832

D:Korean Battery Safety Translation	
E:Russian Battery Safety Translation	
.....	.844
F: Keysight Software End-User Licensing Agreement (EULA)	
.....	.856

# 1 Overview

## Models and Options

**Table 1-1 Models**

Model	Max Freq (GHz)	Description
N9913B	4	Vector Network Analyzer AND Spectrum RF Analyzer
N9914B	6.5	Vector Network Analyzer AND Spectrum RF Analyzer
N9915B	9	Vector Network Analyzer AND Spectrum Microwave Analyzer
N9916B	14	Vector Network Analyzer AND Spectrum Microwave Analyzer
N9917B	18	Vector Network Analyzer AND Spectrum Microwave Analyzer
N9918B	26.5	Vector Network Analyzer AND Spectrum Microwave Analyzer
N9950B	32	Vector Network Analyzer AND Spectrum Microwave Analyzer
N9951B	44	Vector Network Analyzer AND Spectrum Microwave Analyzer
N9952B	50	Vector Network Analyzer AND Spectrum Microwave Analyzer
N9953B	54	Vector Network Analyzer AND Spectrum Microwave Analyzer
N9933B	4	Spectrum Microwave Analyzer
N9934B	6.5	Spectrum Microwave Analyzer
N9935B	9	Spectrum Microwave Analyzer
N9936B	14	Spectrum Microwave Analyzer
N9937B	18	Spectrum Microwave Analyzer
N9938B	26.5	Spectrum Microwave Analyzer
N9960B	32	Spectrum Microwave Analyzer
N9961B	44	Spectrum Microwave Analyzer
N9962B	50	Spectrum Microwave Analyzer
N9963B	54	Spectrum Microwave Analyzer

Minimum Frequency: 30 kHz for all VNA models; 9 kHz for all SA models (usable to 5 kHz)

FieldFox Options: For a comprehensive list, view the FieldFox Configuration Guide at: <http://literature.cdn.keysight.com/litweb/pdf/5992-3701EN.pdf>

## Accessories

The following accessories are included with every FieldFox. Spare accessories can be ordered at any time. Refer to **Table 1-2**. Some of the optional accessories—not included unless requested—are listed in **Table 1-3**. For more, refer to <http://www.keysight.com/find/fieldfox>.

**Table 1-2** Accessories

Accessory Part Number	Description
N9910X-873	AC/DC Adapter (except for US/Canada) <sup>a</sup>
N9910X-876	Lithium-Ion Battery (High Capacity)
N9910X-877	AC/DC Adapter for US / Canada only <sup>a</sup>
N9910X-880	Soft-case w/ Backpack & Shoulder Strap
N9910X-891	Quick Reference Guide (printed copy)

a. Depending on your region, the FieldFox comes with either a N9910X-873 AC/DC adapter or a N9910X-877 AC/DC adapter.

## Optional Accessories

**Table 1-3** Optional Accessories (partial list)

Optional Accessory Part Number	Description
N9910X-872	External battery charger
N9910X-876	17 mm torque wrench
N9910X-887	Replacement Fan Kit

### NOTE

Although not supplied, a USB keyboard and mouse CAN be used with the FieldFox.

To see a complete list of accessories that are available for the FieldFox, please visit: <http://www.keysight.com/find/fieldfox>.

## FieldFox Manuals, Software, and Supplemental Help

The following manuals and software are available for the FieldFox.

To access all of these, visit: [www.keysight.com/find/fieldfoxsupport](http://www.keysight.com/find/fieldfoxsupport)

- **User’s Guide** – This manual, included with shipment.
- **Quick Reference Guide** – Printed copy with laminated pages for outdoor use included with shipment.
- **Supplemental Online Help** – Concepts and Reference information.  
**Programming Guide – Online, off line and pdf versions.**  
<http://na.support.keysight.com/fieldfox/help/SupHelp/FieldFox.htm>
- **FieldFox Data Link Software and Help** – Free download. Includes help on editing calibration kits and cable files. Refer to  
<http://www.keysight.com/main/software>.
- **Service Guide** – Free download.
- **Firmware Updates** – Check to see if you have the latest FieldFox firmware.

### Conventions that are used in the Manual

- **Hardkey** indicates a front panel button. The functionality of these buttons does not change.

The six Softkey menus change dynamically and follow these color conventions:

- **Softkey** Blue indicates an available setting.
- **Softkey** Green indicates a change in menu level when selected.
- **Softkey** Black indicates the default or selected setting.
- **Softkey** Yellow indicates an active entry in process.
- **Softkey** Grey indicates a key that is NOT available.

### Safety Notes

The following safety notes are used throughout this manual. Familiarize yourself with each of the notes and its meaning before operating this instrument. More pertinent safety notes for using this product are located in **Chapter 34, “Safety Considerations”, on page 801.**

#### CAUTION

Denotes a hazard. It calls attention to a procedure that, if not correctly performed or adhered to, would result in damage to or destruction of the product. Do not proceed beyond a caution note until the indicated conditions are fully understood and met.

---

**WARNING**

Denotes a hazard. It calls attention to a procedure which, if not correctly performed or adhered to, could result in injury or loss of life. Do not proceed beyond a warning note until the indicated conditions are fully understood and met.

---

## 2 Preparing for Initial Use of Your New FieldFox

### Check the Shipment

When you receive your FieldFox, check the shipment according to the following procedure:

1. Inspect the shipping container for damage. Signs of damage may include a dented or torn shipping container or cushioning material that indicates signs of unusual stress or compacting. If not damaged, save the packaging material in case the FieldFox needs to be returned
2. Carefully remove the contents from the shipping container, and verify that the standard accessories and your ordered options are included in the shipment according to the Box Contents List
3. For any question or problems, refer to **“Contacting Keysight” on page 5**

### Meeting Power Requirements for the AC/DC Adapter

<b>Voltage:</b>	100 VAC to 240 VAC
<b>Frequency:</b>	50 Hz to 60 Hz
<b>Current:</b>	1.5 A (100 VAC) to 0.75 A (240 VAC)

The AC/DC adapter supplied with the analyzer is equipped with a three-wire power cord, in accordance with international safety standards. The power cable appropriate to the original product shipping location is included with the FieldFox.

Various AC power cables are available from Keysight that are unique to specific geographic areas. You can order additional AC power cables that are correct for use in different areas. For the power cord part number information please visit: <http://www.keysight.com/find/fieldfox>

## Install the Lithium-Ion Battery



Step	Notes
1. Open the battery door	Push the button on the battery compartment door while sliding the door outward.
2. Insert the battery.	The terminals end of the battery is inserted into the compartment.
3. Close the battery door.	Slide the battery compartment door upwards until it latches.

### Battery Usage

When you receive your FieldFox, the lithium-ion battery is not installed, and it is partially charged to approximately 40% to preserve battery life. A lithium-ion battery has no memory effect, so it can be used partially charged, as shipped.

A fully charged battery will power your FieldFox for about four hours, so if you plan to use it for this long, you should fully charge the battery.

#### NOTE

The FieldFox will shut down to prevent the battery from discharging to a level that is damaging. If this occurs, charge the battery either internally or externally.

Learn more about the lithium-ion battery in [Chapter 33, “Working with the Lithium-Ion Battery.”](#)

Battery charge status is viewable:

-  In the upper-right corner of the screen.
- On the Battery screen. To access the screen, select **System**, **Service**, **Diagnostics**, and **Battery**.

- On the battery. Open the FieldFox battery compartment door to view the battery LCD.

#### To conserve battery power:

- Use **Run/Hold** to single-trigger a measurement when needed. **Hold** is shown on the display.
- Press **System** then **Display** then **Brightness**. Use the **▲▼** arrows, the rotary knob, or numeric keypad to adjust the brightness to dim the FieldFox display as much as possible.
- Briefly press the power button > Standby, to switch to Standby mode when the FieldFox is not being used. Press power button again to restore power. All current settings are preserved.

#### NOTE

When powered by the battery only, the FieldFox can stay in Standby mode for a maximum of four hours and then it powers off automatically. When the relative battery charge drops by about 20%, the FieldFox will power off to preserve the remaining charge.

---

#### To recharge a battery:

Use ONLY a FieldFox charger to recharge a battery.

- The battery can be fully charged while in the FieldFox in about 4 hours with the FieldFox either ON or OFF.
- The battery can be fully charged externally using the external battery charger in about 4 hours.
- When the battery is removed, the FieldFox can still be powered by the AC/DC adapter.

## FieldFox ON/OFF Settings

#### NOTE

The FieldFox power button shut down/standby sequence includes a 10 second counter that allows you to either choose a softkey to immediately initiate the action (**Standby**/**Shut down**/**Restart\***), or to let the countdown counter expire after 10 seconds then perform the action. \*Restart can only be enabled via the Restart softkey.

---

- To turn power **ON**, briefly press the power button. Boot-up takes about 1 minute.
- To switch to **Standby** mode (low battery drain), briefly press the power button. See the Note above concerning Stand By.

- To turn Power **OFF** (very low battery drain), press the power button briefly and press the Shutdown softkey. Data and instrument state are NOT automatically saved when the FieldFox is powered OFF. Learn how to save data and instrument state in **Chapter 32, “File Management”, on page 777**. See the Note above concerning Shut down.
- To restart FieldFox, press the power button and press **Restart**. See the **Note** above concerning Restart.
- Press **Cancel** to exit the power down sequence.
- You can also access the power down softkey menu choices (**Standby**, **Shut down**, **Restart**, and **Cancel**) by using the **Mode** hardkey:
- Press **Mode**
  - Then **More**
  - Then **Shut down**
- You can make a setting to automatically **Power ON** the FieldFox when a power source is connected. Learn how on **“Power ON” on page 766**.

## Power Button LED Status

Solid green	Power is ON
Blinking green	FieldFox in Stand By mode
Blinking amber <sup>a</sup>	Battery charging when the FieldFox power is off
Blinking amber and green	Stand By mode and battery charging
Not lit	Power is Off and battery is not charging

a. LED showing a repeating ramping-up of the intensity of the LED to indicate the battery is charging.

## FieldFox High Temperature Protection

The following features prevent degradation or damage in the event of high internal temperatures in the FieldFox.

### NOTE

**Do NOT store the FieldFox in the soft-case while powered ON or in Standby mode.**

How to monitor the internal FieldFox temperature:

- Press **System**, then **Service Diagnostics**.
- Then **Internal Temperatures**.

- The average temperature that is displayed for the Internal Temperature is the average of the RF1, RF2, SB1, SB2 temperatures. These temperatures come from internal sensors embedded within the FieldFox.

The average temperature does **not** include the CPU or the battery temperatures. The FieldFox does **not** measure the CPU and battery temperatures.

## Temperature Control Mode

The FieldFox's internal temperature control preserves measurement accuracy and maintains the long-term reliability of the FieldFox. See also, "**High-Temp Shutdown Warning (RTSA Mode Only)**" on page 35.

### NOTE

Measurement speed specifications do NOT apply in Temperature Control Mode.

### Entering Temperature Control Mode

At an average internal temperature of above approximately 64°C, the FieldFox enters Temperature Control mode by reducing display intensity. This should decrease the internal temperature which preserves measurement accuracy and maintains the long-term reliability of the FieldFox. Refer to **Figure 2-1**.

In addition, duty cycling is enabled when the internal average temperature of the FieldFox reaches the duty cycling threshold of above ~64°C. All applications (except RTSA): Power for internal circuitry is turned off between sweeps and delaying occurs for the next sweep. In RTSA mode, power is only turned off, if the FieldFox is in Single Sweep or Hold.

All applications (including RTSA): Display dims to 40% at ~64°C.

For all modes, except RTSA mode, you will see the following messages displayed for ~3 seconds:

```
"Automatic Meas Duty Cycling activated for thermal management"
```

Later if the temperatures are reduced:

```
"Temperatures reduced, ending Automatic Meas Duty Cycling"
```

For RTSA mode (where duty cycling is not possible), you will see the following messages displayed for ~3 seconds:

```
"Entering Auto Protect mode for thermal management"
```

Later if the temperatures are reduced:

```
"Temperatures reduced, exiting Automatic Protect Mode"
```

### Entering Auto Protect (Maximum) Threshold Temperature Mode

At above approximately 75°C, the FieldFox enters (Maximum) Auto Protect temperature control mode by displaying the "Entering Auto Protect mode...". See also [Table 2-1 on page 36](#).

When you enter the Auto Protect (Maximum) Threshold, the following message is displayed:

"Entering Maximum Auto Protect mode for thermal management"

When temperature reaches the maximum protection threshold (~75°C), some applications take additional measures.

Figure 2-1

Entering Auto Protect mode message (above ~64°C)—(Displays for 3 sec)



### Exiting Maximum Auto Protect Threshold Temperature Mode

When the temperature drops to approximately 73.5°C, a message is displayed indicating that the FieldFox is leaving Temperature Control Mode and normal operating settings are restored (refer to [Figure 2-2](#)). See also, [Table 2-1 on page 36](#).

When you exit the Auto Protect (Maximum) Threshold control mode, the following message is displayed:

"Temperatures reduced, exiting Maximum Auto Protect mode"

Figure 2-2

Exiting Maximum Auto Protect mode message—(~62.5°C)

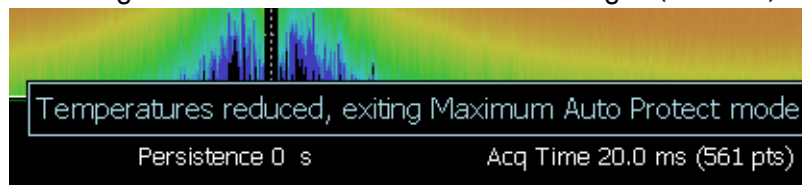

## High-Temp Shutdown Warning (RTSA Mode Only)

In extreme situations, Temperature Control mode may not stop an increase in the FieldFox internal temperature. Just prior to shut down, the FieldFox will display a warning of imminent shut down and the instrument turns off. At above approximately 77°C, a Maximum Auto Protect message—(Top "WARNING..." message) displays for 9 sec. Red text at left bottom corner of display remains on until internal temperature returns to ~75.5°C. At above ~78°C, High-Temperature Shut down will engage and turn OFF the FieldFox. Refer to [Figure 2-3](#). See also, [Table 2-1 on page 36](#).

Figure 2-3 Shutdown Warning message—(above ~77°C) - (RTSA Mode Only!)

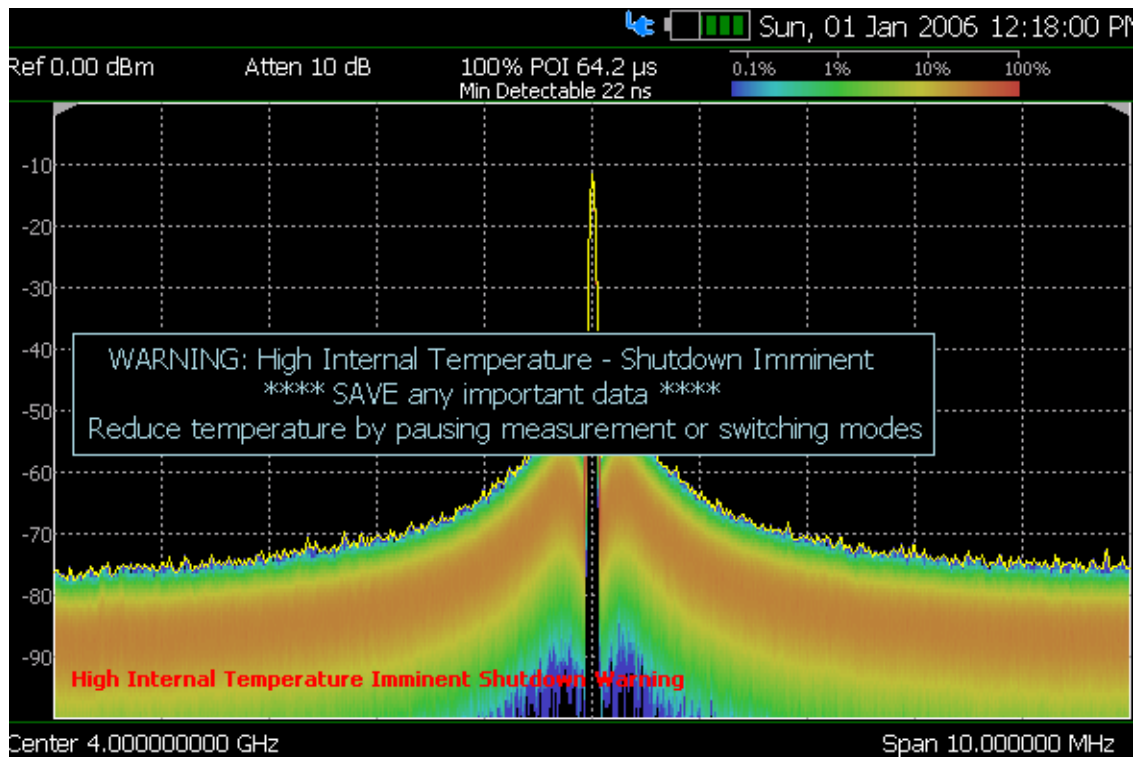

## Summary of FieldFox Average Internal Temperature Protection Behavior

Table 2-1 Summary of FieldFox Temperature Protection

Threshold	Average Internal Temperature	Description of Behavior
Duty cycling	~64°C	Duty cycling is enabled when the internal average temperature of the FieldFox reaches the duty cycling threshold of ~64°C. Power is turned off between sweeps and delaying occurs for the next sweep.  In RTSA mode power is only turned off in Single Sweep or Hold. This enables you to control your instrument's temperature when you don't need to make a measurement by using the "Run/Hold" hardkey to pause the sweep.  All applications (including RTSA): Display dims to 40% at ~64°C.
Maximum Protect (Initial)	~75°C	When temperature reaches the maximum protection threshold (~75°C) some applications take additional measures.
1 degree below shutdown (RTSA Mode Only)	~77°C	RTSA Shutdown Warning (~77°C) – (Top "WARNING..." message displays for 9 sec). Red text at bottom of display remains on until internal temperature returns to ~75.5°C. Refer to <a href="#">Figure 2-3 on page 35</a> .
Shutdown	~78°C	Instrument shuts down.
Exit Duty Cycle	~62.5°C	The temperature required to come out of the duty cycle threshold.

## Avoid Overpowering the FieldFox

The FieldFox can be damaged with too much power or voltage applied. Exceeding the maximum RF power levels shown below will cause an ADC Over Range message to appear on the screen.

### CAUTION

#### Maximum Input Voltages and Power:

RF Output Connector: 50V DC, +23 dBm RF

Ext Trig/Ref Connector: 5.5 V DC

#### RF Input:

+27 dBm RF, ±50 VDC Max. (N991xA/B, N9925B, N9926A, N9928A, N993xA/B)

+23 dBm RF, ±50 VDC Max. (N9923A, N9923AN)

+25 dBm RF, ±40 VDC Max. (N995xA/B, N996xA/B)

DC Input: 19VDC, 4ADC, 60 Watts maximum when charging battery

Learn more about Maximum power and voltages in the FieldFox Data Sheet.

**NOTE**

Very often, coaxial cables and antennas build up a static charge, which, if allowed to discharge by connecting to the FieldFox, may damage the instrument input circuitry. To avoid such damage, it is recommended to dissipate any static charges by temporarily attaching a short to the cable or antenna prior to attaching to the FieldFox.

---

# Take the FieldFox Tour

## Front Panel

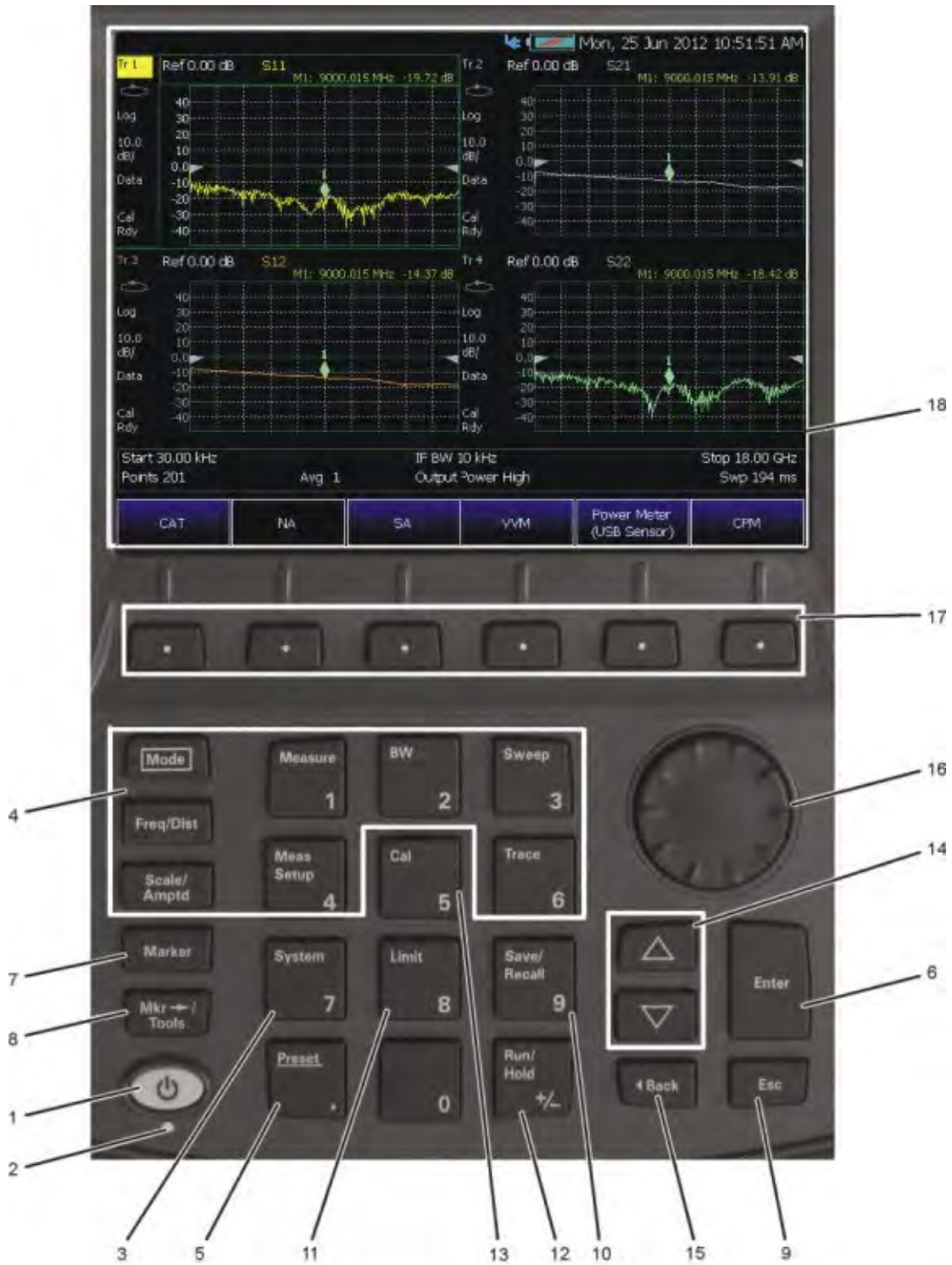

N9912\_001\_401

Preparing for Initial Use of Your New FieldFox  
Take the FieldFox Tour

No.	Caption	Description	Learn More:
1	Power	ON: press momentarily. STAND BY: with FieldFox power ON, press briefly. OFF: press and hold until the FieldFox shuts off (about 4 seconds).	<a href="#">“FieldFox ON/OFF Settings” on page 31</a>
2	LED	Not lit: FieldFox OFF, not charging Green: FieldFox ON. Charging status indicated by battery icon on screen Orange, flashing: FieldFox STAND BY Orange, intensity increasing, flashing slowly: FieldFox OFF, charging	<a href="#">“Power Button LED Status” on page 32</a>
3	<b>System</b>	Displays a sub-menu for system setup	<a href="#">“System Settings” on page 725</a>
4	Function keys	Includes: <b>Freq/Dist</b> , <b>Scale/Amptd</b> , <b>BW</b> , <b>Sweep</b> , <b>Trace</b> , <b>Meas Setup</b> , <b>Measure</b> , and <b>Mode</b> .	Refer to specific Mode.
5	<b>Preset</b>	Returns the analyzer to a known state	<a href="#">“How to Preset the FieldFox” on page 727</a>
6	<b>Enter</b>	Confirms a parameter selection or configuration	--
7	<b>Marker</b>	Activates marker function	<a href="#">“All about Markers” on page 700</a>
8	<b>Mkr--&gt;Tools</b>	Displays a sub-menu for marker functions	<a href="#">“All about Markers” on page 700</a>
9	<b>Esc</b>	Exits and closes the Active Entry dialog box or clears the character input	--
10	<b>Save/Recall</b>	Saves the current trace or recalls saved data from memory	<a href="#">“Saving and Recalling Files” on page 778</a>

Preparing for Initial Use of Your New FieldFox  
Take the FieldFox Tour

No.	Caption	Description	Learn More:
11	<b>Limit</b>	Sets limit lines for quick Pass/Fail judgment	<a href="#">“All about Limit Lines” on page 715</a>
12	<b>Run/Hold</b>	Toggles between free Run and Hold/Single operation.	<a href="#">“Run/Hold” on page 726</a>
13	<b>Cal</b>	Displays a sub-menu for calibration functions	<a href="#">“Calibration Method Summary” on page 146</a>
14	Arrow keys	Increases or decreases a value or setting.	--
15	<b>◀Back</b>	Returns to the previous menu selection.	--
16	Rotary knob	Highlights an item for selection, or enables incremental changes to values.	--
17	Softkeys	Allows selection of settings for configuring and performing measurements, and for other FieldFox functions.	--
18	Screen	Transflective screen, viewable under all lighting conditions. If you are using your FieldFox in direct sunlight, you do not need to shield the display from the sunlight. In bright lighting conditions, the display is brighter and easier to read when you allow light to fall directly on the screen. Alternative color modes exist that maximize viewing in direct sunlight conditions, as well as other conditions such as nighttime work.	<a href="#">“Screen Tour” on page 44</a>

**NOTE**

Clean the Transflective screen with gentle and minimal wiping using Isopropyl alcohol applied to a lint-free cloth.





## Top Panel



Caption	Descriptions	Learn More:
Port 1 RF Output	For CAT and NA measurements, use to make reflection measurements. Maximum: $\pm 50$ VDC, +27 dBm RF Also, for SA source output in SA mode.	<a href="#">“CAT Mode Settings” on page 51</a> <a href="#">“NA Mode Settings” on page 91</a> Chapter 9, “SA (Spectrum Analyzer Mode (Option 233–Mixed Analyzers))”, on page 147
Port 2 SA RF Input	For SA, use to make all measurements. For CAT, NA, and VVM mode, use to make Port 2 transmission measurements. Maximum: $\pm 50$ VDC, +27 dBm RF.	<a href="#">“SA Mode Settings” on page 151</a>
GPS Ant	SMA (f) connector for use with built-in GPS. Produces a settable 3.3 VDC or 5 VDC bias voltage for the antenna pre-amplifier. Use with a GPS antenna such as N9910X-825. Other GPS antennas can also be used.	<a href="#">“GPS” on page 746</a>
Ref In Trig In	SMA (f) connector for use with Frequency Reference Source and External Trigger Input signal. Maximum: 5.5 VDC.	<a href="#">“Frequency Reference Source” on page 760.</a> <a href="#">“Triggering” on page 192</a>

## Right Side Panel

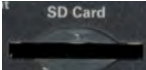



Connector	Description	Learn More:
	<p>Ethernet cable connector to read trace data using the FieldFox Data Link Software and connect to the FieldFox remotely.</p> <p>Download the latest version of the software at: <a href="http://www.keysight.com/find/fieldfoxsupport">www.keysight.com/find/fieldfoxsupport</a></p>	<p><b>“LAN Settings” on page 764</b></p>
	<p>IF Out used in SA mode for external signal processing.</p>	<p><b>“IF Output” on page 185</b></p>
	<p>Frequency Reference Source Output Trigger Output (ERTA mode).</p>	<p><b>Chapter 25, “ERTA (Extended Range Transmission Analysis) Mode - Option 209”, on page 597</b></p>
	<p>Secure Digital slot. Use to extend the memory of the FieldFox.</p>	<p><b>“Saving and Recalling Files” on page 778</b></p>
	<p>The mini-USB port can be connected to your PC’s standard USB port to send SCPI commands.</p> <p><b>NOTE</b></p> <p><b>IMPORTANT!</b> It is recommended that only USB certified cables are used with the FieldFox.</p>	<p><b>Chapter 31, “Using the Mini-USB Port to send SCPI Commands and Queries”, on page 775</b></p>
	<p>Two standard USB connectors used to connect a power sensor for Power Meter Mode. Also used to save files to a USB flash drive.</p> <p><b>NOTE</b></p> <p><b>IMPORTANT!</b> It is recommended that only USB certified cables are used with the FieldFox.</p>	<p><b>“Saving and Recalling Files” on page 778</b></p>

Preparing for Initial Use of Your New FieldFox  
Take the FieldFox Tour

Left Side Panel

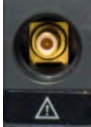

Connector	Description	Learn More:
	Audio output jack for use with SA Mode Tune and Listen.	<a href="#">“Tune &amp; Listen (AM/FM)” on page 166</a>
	DC Voltage Source for use with external DC Bias.	<a href="#">“Variable Voltage Source (Opt. 309)” on page 761</a>
	DC power connector used to connect to the AC/DC adapter. Maximum: 19 VDC, 4 ADC.	<a href="#">“Internal Charging with the AC/DC Adapter” on page 795</a>

## Screen Tour

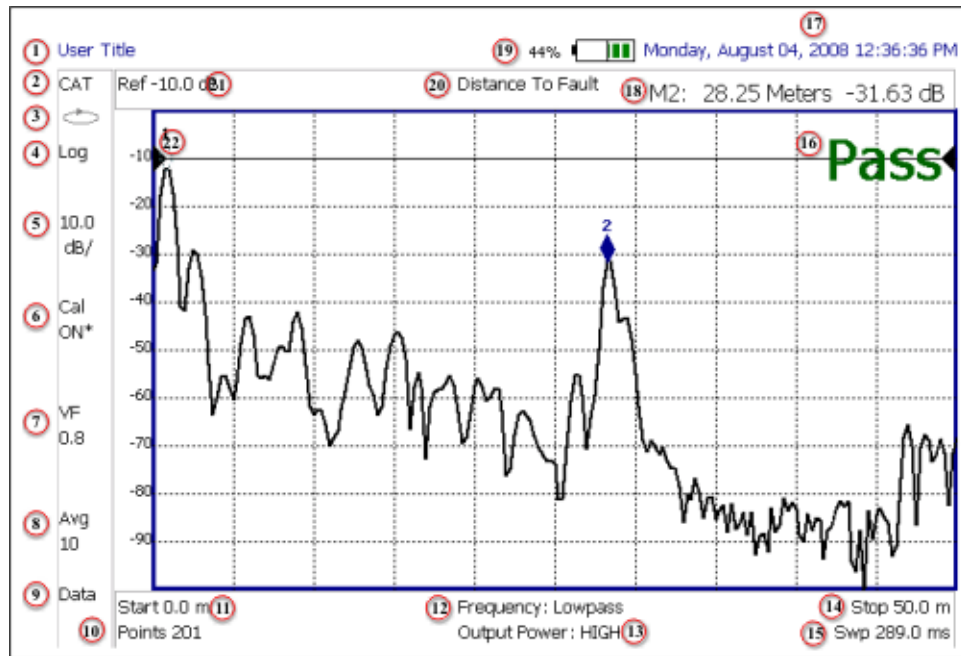

Caption	Description	Learn More:
1	Title – write your own text here	<a href="#">“Title” on page 730</a>
2	Current Mode	--
3	Run / Hold	<a href="#">“Run/Hold” on page 726</a>
4	Display Format	Mode dependent
5	Scale/division	Mode dependent
6	Calibration Status (CAT and NA) Detection Method (SA)	<a href="#">“Cal ON? – Questionable Accuracy” on page 142</a>
7	Velocity Factor (Fault Meas)	<a href="#">“About Velocity Factor and Cable Loss” on page 69</a>
8	Averaging Status and Count	Mode dependent
9	Data / Mem Display (CAT and NA) Step / FFT (SA)	<a href="#">“All about Trace Math” on page 720</a> <a href="#">“Resolution Bandwidth (Res BW)” on page 182</a>
10	Resolution Setting	Mode dependent
11	Measurement Start Freq or Distance	Mode dependent

Preparing for Initial Use of Your New FieldFox  
Take the FieldFox Tour

Caption	Description	Learn More:
12	Bandpass / Lowpass setting (Fault Meas) IF BW in NA Mode	<a href="#">“DTF Measurement Settings” on page 66</a>
13	Output Power Level (CAT and NA)	<a href="#">“Output Power” on page 57</a>
14	Measurement Stop Freq or Distance	Mode dependent
15	Actual Sweep Time	Mode dependent
16	Limit Line Status	<a href="#">“All about Limit Lines” on page 715</a>
17	Time and Date	<a href="#">“Date and Time” on page 746</a>
18	Marker Readout	<a href="#">“All about Markers” on page 700</a>
19	Battery Status	<a href="#">“Viewing the Battery Charge Status” on page 793</a>
20	Measurement Type (CAT and NA)	--
21	acquisition	Mode dependent
22	Reference Position	Mode dependent

## How to Enter Numeric Values

Many settings on the FieldFox require the entry of numeric values.

### How to enter numeric values

Use any combination of the following keys:

- Numeric 0–9 keys, along with the polarity (+/-) key.
- Up/Down arrow keys to increment or decrement values.
- Rotary knob to scroll through a set of values.
- **Back** erases previously entered values.
- **Esc** exits data entry without accepting the new value.

To complete the setting, press **Enter** or a different **softkey** or **hardkey**.

## Multiplier Abbreviations

Many times after entering numeric values, a set of multiplier or suffix softkeys are presented. The following explains the meaning of these abbreviations.

### Select Frequency multipliers as follows:

- **GHz** Gigahertz (1e9 Hertz)
- **MHz** Megahertz (1e6 Hertz)
- **KHz** Kilohertz (1e3 Hertz)
- **Hz** Hertz

Select Time multipliers as follows:

- **s** Seconds
- **ms** milliseconds (1e-3)
- **us** microseconds (1e-6)
- **ns** nanoseconds (1e-9)
- **ps** picoseconds (1e-12)

## Connector Care

- Never store connectors, airlines, or calibration standards loose in a box. This is a common cause of connector damage.
- Install protective end caps when connectors are not in use.
- Keep connector temperature the same as the test instrument. Holding the connector in your hand or cleaning connector with compressed air can significantly change the temperature. Wait for connector temperature to stabilize before using in calibration or measurements.
- Do not touch the mating plane surfaces. Natural skin oils and microscopic particles of dirt are difficult to remove from these surfaces.
- Do not set connectors contact-end down on a hard surface. The plating and mating plane surfaces can be damaged if the interface comes in contact with any hard surface.
- Wear a grounded wrist strap and work on a grounded, conductive table mat. This helps protect the analyzer and devices from electrostatic discharge (ESD).
- Refer to **“Connector Care Review” on page 827**.

### CAUTION

Because of the very small and precise mechanical tolerances of mmWave connectors, minor defects, damage, and dirt can significantly degrade repeatability and accuracy. In addition, a dirty or damaged connector can destroy connectors that are mated to it. For this reason, NEVER use a damaged connector. See also [http://na.support.keysight.com/pna/connectorcare/Connector\\_Care.htm](http://na.support.keysight.com/pna/connectorcare/Connector_Care.htm)

---

Preparing for Initial Use of Your New FieldFox  
Connector Care

### 3 CAT (Cable and Antenna Test) Mode

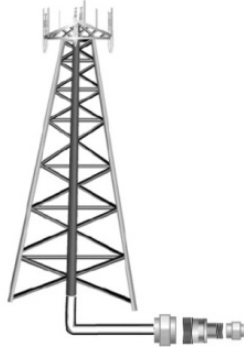

CAT Mode is typically used to test an entire transmission system, from the transmitter to the antenna. This process is sometimes referred to as Line Sweeping.

CAT Mode is similar to NA (Network Analyzer) Mode. Learn more in the Supplemental Online Help: <http://na.support.keysight.com/fieldfox/help/SupHelp/FieldFox.htm>

CAT Mode Distance to Fault measurements are discussed in [Chapter 4, "DTF \(Distance to Fault\) Measurements."](#)

#### NOTE

**IMPORTANT!** For CAT and NA modes, limit lines do not apply where  $F1 = F2$ .

#### In this Chapter

["Measurement Selection" on page 51](#)

["Quick Settings Table" on page 52](#)

["Frequency Range" on page 53](#)

["Scale Settings" on page 53](#)

["Averaging" on page 54](#)

["Smoothing" on page 55](#)

["Single or Continuous Measure" on page 55](#)

["Resolution \(Number of Data Points\)" on page 56](#)

["Sweep Time" on page 56](#)

["Output Power" on page 57](#)

["Interference Rejection" on page 58](#)

["Coupled Frequency" on page 58](#)

CAT (Cable and Antenna Test) Mode

Procedures

[“Return Loss Measurements” on page 60](#)

[“1-Port Cable Loss Measurements” on page 60](#)

[“2-Port Insertion Loss Measurements” on page 62](#)

### **See Also**

[Chapter 8, “Calibration for NA, CAT, and VVM Modes”, on page 125](#)

[“All about Markers” on page 700](#)

[“All about Limit Lines” on page 715](#)

[“All about Trace Math” on page 720](#)

Making 75 $\Omega$  (ohm) Measurements at the FieldFox Supplemental Online Help:  
<http://na.support.keysight.com/fieldfox/help/SupHelp/FieldFox.htm>

## CAT Mode Settings

Select CAT Mode before making any setting in this chapter.

### How to select CAT Mode

- Press **Mode**.
- Then **CAT/TDR**.

### Measurement Selection

#### How to select a CAT Mode Measurement

Learn more about the following measurements in the Supplemental Online Help: <http://na.support.keysight.com/fieldfox/help/SupHelp/FieldFox.htm>

Press **Measure 1**.

Then choose one of the following: These softkeys also appear after CAT Mode is selected.

- **Distance To Fault** 1-port reflection measurement that uses Inverse Fourier Transform (IFT) calculations to determine and display the distance to, and relative size of, a fault or disruption in the transmission line. Units are in return loss format, expressed as a positive number in dB, unless the measurement selected is DTF (VSWR). Learn more about DTF Measurements refer to **Chapter 4, “DTF (Distance to Fault) Measurements.”**
- **Return Loss & DTF** Displays both a Return Loss measurement and a DTF measurement. Use this format to display the frequency settings that are used to make the DTF measurement. The frequency range settings for these two measurements can be coupled or uncoupled. Learn more on **page 58**.

Calibrations are applied to both traces

When in Hold mode and Single sweep is performed, only the active trace is triggered. Use the **▲▼** arrows to activate a trace

- **Return Loss** 1-port reflection measurement that displays the amount of incident signal energy MINUS the amount of energy that is reflected. The higher the trace is on the screen, the more energy being reflected back to the FieldFox. Learn how to measure Return Loss on **page 60**.
- **VSWR** (Voltage Standing Wave Ratio – also known as SWR) 1-port reflection measurement that displays the ratio of the maximum reflected voltage over the minimum reflected voltage. The higher the trace is on the screen, the more energy being reflected back to the FieldFox.
- **DTF (VSWR)** Distance to Fault in VSWR format.

- **Cable Loss (1-Port)** 1-port reflection measurement that displays the loss of a transmission line. Learn more on [page 60](#)
- **Insertion Loss (2-Port)** 2-port transmission measurement that accurately displays the loss through a cable or other device in dB. Both ends of the cable must be connected to the FieldFox. NO phase information is included in this measurement. Learn more at [“2-Port Insertion Loss Measurements” on page 62](#). This feature is available only with an option on some FieldFox models. For detailed information, please view the FieldFox Configuration Guide at: <http://literature.cdn.keysight.com/litweb/pdf/5992-3701EN.pdf>
- **DTF (Lin)** Distance to Fault in Linear format.
- **TDR (Lin rho)** The Y-axis of the display is linear, real, unitless values. A trace without reflections shows as 0 (zero). Maximum reflections from an open or short show as 1.
- **TDR (ohm)** The Y-axis of the display is impedance (ohms).
- **TDR & DTF** TDR and DTF are displayed.

## Quick Settings Table

Both CAT and NA Modes allow you to view and change most relevant settings from a single location. All of these settings are discussed in this chapter and, unless otherwise noted, ALL of these settings can also be made using the standard softkey menus.

### How to view and change Quick Settings

- Press **Meas Setup 4**.
- Then **Settings**.
- Press **Next Page** and **Previous Page** to view all settings. If these softkeys are NOT available, then all available settings fit on one page.
- To change a setting:
  - Use the **▲▼** arrows to highlight a setting.
  - Then press **Edit**. The current setting changes to **yellow**.
  - Some settings require you to press a softkey to change the value. Otherwise, use the numeric keypad, **▲▼** arrows, or rotary knob to change the value.
  - When finished changing a value, press **Done Edit**.
- Press **Dock Window** to relocate the Settings table to a position relative to the trace window. The Dock Window setting persists through a Preset. Choose from the following
  - **Full** (Default setting) Only the Settings table is shown on the screen. The trace window is temporarily not shown

- **Left** The Settings table is shown to the left of the trace window
- **Bottom** The Settings table is shown below the trace window
- When finished changing ALL settings, press **Done** to save your settings

## Frequency Range

Set the range of frequencies over which you would like to make CAT Mode measurements

When the frequency range is changed after a calibration is performed, the cal becomes interpolated. Learn more in [“Interpolation \\*” on page 142](#).

### How to set Frequency Range

- Press **Freq/Dist**.
- Then choose from the following
  - **Start** and **Stop** frequencies - beginning and end of the sweep.
  - **Center** and **Span** frequencies – the center frequency and span of frequencies (half on either side of center).
- Follow each setting by entering a value using the numeric keypad, **▲▼** arrows, or the rotary knob.
  - After using the keypad, select a multiplier key. Learn about multiplier abbreviations in [Chapter 1, “Overview.”](#)
  - After using the **▲▼** arrows or the rotary knob, press **Enter**. The amount of frequency increment is based on the current span and can NOT be changed in CAT Mode.

## Scale Settings

Adjust the Y-axis scale to see the relevant portions of the data trace. The Y-axis is divided into 10 graticules.

This setting can be changed at any time without affecting calibration accuracy.

### How to set Scale

- Press **Scale / Amptd**.
- Then choose from the following three methods:
  1. **Autoscale** Automatically adjusts the Y-axis to comfortably fit the Minimum and Maximum amplitude of the trace on the screen.
  2. Set Scale, acquisition, and Reference Position:
    - **Scale** Manually enter a **scale per division** to view specific areas of the trace

- **Ref Level** Manually set the value of the reference line. Enter a negative value by pressing **Run/Hold (+/-)** either before or after typing a value
  - **Ref Pos** Manually set the position of the reference line. Values must be between **0** (TOP line) and **10** (BOTTOM line)
3. Set Top and Bottom graticule values. The scale per division is calculated.
- **Top** to set the value of the Top graticule.
  - **Bottom** to set the value of the Bottom graticule.
  - Enter a negative value by pressing **Run/Hold (+/-)** either before or after typing a value.

#### Scale annotation on the FieldFox screen

Reference Line = red arrow  
Ref Level = -40 dB  
Ref Position = 1  
Scale = 2 dB per division

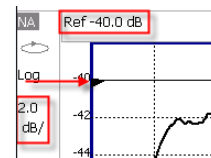

## Averaging

Trace Averaging helps to smooth a trace to reduce the effects of random noise on a measurement. The FieldFox computes each data point based on the average of the same data point over several consecutive sweeps.

Average Count determines the number of sweeps to average; the higher the average count, the greater the amount of noise reduction.

An average counter is shown in the left edge of the screen as **Avg N**. This shows the number of previous sweeps that have been averaged together to form the current trace. When the counter reaches the specified count, then a 'running average' of the last **N** sweeps is displayed. Average Count = 1 means there is NO averaging.

This setting can be changed at any time without affecting calibration accuracy.

### NOTE

Averaging is often used to increase the dynamic range of a measurement. To achieve the highest dynamic range, select NA mode and reduce the IF Bandwidth setting. Learn more about dynamic range in **"Increase Dynamic Range" on page 112**.

## How to set Trace Averaging

- Press **BW 2**.

- Then **Average N** where **N** is the current count setting.
- Enter a value using the numeric keypad. Enter 1 for NO averaging.
- Press **Enter**.
- While Trace Averaging is in process, press **Sweep 3** then **Restart** to restart the averaging at 1.

## Smoothing

Trace smoothing averages a number of adjacent data points to smooth the peak-to-peak noise values on a displayed trace. The number of adjacent data points that are averaged is known as the smoothing aperture. Aperture is set by specifying a percentage of the X-axis span.

Trace smoothing does NOT significantly increase measurement time.

Smoothing can be used with any CAT format.

When enabled, **Smo** appears on the FieldFox screen.

How to set Smoothing

- Press **BW 2**.
- Then **Smoothing ON OFF**.
- Then **Sm. Aperture** and enter a value between 0 and 25 (percent) using the numeric keypad.
- Press **Enter**.

## Single or Continuous Measure

This setting determines whether the FieldFox sweeps continuously or only once each time the **Single** button is pressed. Use **Single** to conserve battery power or to allow you to save or analyze a specific measurement trace.

This setting can be changed at any time without affecting calibration accuracy.

### How to set Single or Continuous

- Press **Sweep 3**.
- Then choose one of the following:
  - **Single** Automatically sets Continuous OFF and causes FieldFox to make ONE sweep, then hold for the next Single key press. Hold is annotated in the upper left corner of the display when NOT sweeping, and changes to an arrow --> while the sweep occurs
  - **Continuous** Makes continuous sweeps. This is the typical setting when battery power is not critical.

You can also use **Run / Hold +/-** to toggle between Single and Continuous.

## Resolution (Number of Data Points)

Data points are individual measurements that are made and plotted across the X-axis to form a trace. Select more data points to increase measurement resolution. However, more data points require more time to complete an entire measurement sweep

When the Resolution is changed after a calibration is performed, the cal becomes interpolated. Learn more in [“Interpolation \\*” on page 142](#)

### How to set Resolution

- Press **Sweep 3**.
- Then **Resolution**.
- Then choose one of the following:  
**101 | 201 | 401 | 601 | 801 | 1001 | 1601 | 4001 | 10001**.
- Using SCPI, Resolution can be set to any number of points between 3 and 10001. See the Programming Guide at <http://na.support.keysight.com/fieldfox/help/>

## Sweep Time

The fastest possible sweep time is always used as the default setting. Use the **Min Swp Time** setting to slow the sweep time when measuring long lengths of cable.

Learn more in the FieldFox Supplemental Help at:

<http://na.support.keysight.com/fieldfox/help/SupHelp/FieldFox.htm>

The actual sweep time is shown on the FieldFox screen. See [“Take the FieldFox Tour” on page 38](#). To increase the sweep time, enter a value that is higher than the actual sweep time. The increase will not be exactly the amount that you enter, as the actual sweep time is the composite of many factors.

### NOTE

Measurement speed specifications do NOT apply in Temperature Control Mode. Learn more in [Chapter 1, “Overview.”](#)

### How to set Sweep Time

- Press **Sweep 3**.
- Then **Min Swp Time**.
- Enter a value using the numeric keypad.
- Press a multiplier key. Learn more in [“Multiplier Abbreviations” on page 46](#).

## Output Power

Set the power level out of the FieldFox to High, Low, or manually set power level to a value between High and Low.

Generally, the high power setting is used when measuring passive, high-loss devices to place the signal farther from the noise floor. Increasing the power can also help reduce trace noise. However, for devices that are sensitive to high power levels such as amplifiers, use the Low power setting.

For best measurement accuracy, use the Manual power setting at -15 dBm. After calibration, the power level can be decreased for amplifiers, or increased for higher dynamic range.

### CAUTION

Power Level settings in this mode will NOT change Power Level settings in other modes. To help prevent damage to your DUT, use caution when changing modes with your DUT connected to the FieldFox test ports.

---

### How to set Output Power

- Press **Meas Setup 4**.
- Then **Power**
- Then **Output Power**
  - **High** Sets output power to the maximum achievable power at all displayed frequencies. Output power is NOT FLAT across the displayed FieldFox frequency span. Use the High power setting, when better dynamic range and lower noise is desired. Please see **“Specifications/Data Sheet” on page 829** for expected power levels.
  - **Low** Sets output power to approximately -50dBm, FLAT across the displayed FieldFox frequency span.
  - **Man** (Default setting) Sets the output power to -15 dBm, FLAT across the displayed FieldFox frequency span. If flattened power can NOT be achieved, a warning message and beep occurs. To achieve a flattened output power, reduce the power level or stop frequency.
- Then press **Power Level**
- Then enter a value using the numeric keypad, the **▲|▼** arrows, or the rotary knob.
- Press **Enter**.

## Interference Rejection

Use this setting when you suspect that other signals in the area are interfering with a measurement. Interference may look like a spike or lack of stability in the measurement trace. While monitoring a measurement at a specific frequency, toggle this setting between ON and OFF. If the measurement result decreases while ON, then there is an interfering signal in the area. Continue to make measurements with Interference Rejection ON. However, this will slow the measurement speed.

Once enabled, up to SIX sweeps may be required before the interfering signal is neutralized.

This setting can be changed at any time without affecting calibration accuracy.

### How to set Interference Rejection

- Press **Meas Setup 4**.
- Then **Interference Rejection [current setting]**.
- Then choose from the following:
  - **Off** No interference rejection and fastest possible sweep speed
  - **Minimum** The lowest level of Interference rejection.
  - **Medium** The medium level of Interference rejection.
  - **Maximum** The highest level of Interference rejection.

## Coupled Frequency

This setting, especially useful for a Return Loss & DTF measurement, allows both measurements to have different frequency ranges.

### How to set Coupled Frequency

With a Return Loss & DTF measurement present:

- Press **Meas Setup 4**.
- Select the DTF measurement (Tr2) using the **▲▼** arrows.
- Then choose from the following:
  - **Coupled Freq ON** - Both the Return Loss and DTF traces have the same frequency range settings.
  - **Coupled Freq OFF** (default setting) - Both traces are allowed to have individual frequency range settings. When set to OFF:
    - The Return Loss measurement frequency settings are made in the usual manner. Learn how at **“Frequency Range” on page 53**. When a new Start or Stop frequency is selected, Coupled Frequency is automatically set to OFF.

CAT (Cable and Antenna Test) Mode  
CAT Mode Settings

- The DTF measurement is made using the frequencies as determined by the **DTF Frequency Mode** setting. Learn more in **“DTF Measurement Settings”** on page 66.

## Return Loss Measurements

Return loss can be thought of as the absolute value of the reflected power compared to the incident power.

When measuring an OPEN or SHORT, all incident power is reflected and approximately 0 dB return loss is displayed.

When measuring a LOAD, very little power is reflected and values of 40 dB to 60 dB are displayed.

The minus sign is usually ignored when conveying return loss. For example, a component is said to have 18 dB return loss, rather than  $-18$  dB.

### How to Measure Return Loss

- Connect the jumper cable or any adapter used to connect the device under test (DUT).
- Select **Preset** then **Preset** Returns the FieldFox to known settings
- Select **Mode** then **CAT/TDR** (Cable and Antenna Test)
- Then **Return Loss** (Default measurement).
- Press **Freq/Dist** and enter **Start** and **Stop** frequency values of the measurement.
- Press **Meas Setup 4** then **Settings** to make appropriate settings before calibrating.
- Disconnect the jumper cable or DUT and press **Cal 5** then follow the calibration prompts.
- Reconnect the jumper cable or DUT.
- The return loss trace is displayed on the FieldFox screen.

## 1-Port Cable Loss Measurements

While all cables have inherent loss, weather and time will deteriorate cables and cause even more energy to be absorbed by the cable. This makes less power available to be transmitted.

A deteriorated cable is not usually apparent in a Distance to Fault measurement, where more obvious and dramatic problems are identified. A Cable Loss measurement is necessary to measure the accumulated losses throughout the length of the cable.

A 2-port Insertion Loss measurement is usually more accurate than a 1-port Cable Loss measurement. However, to perform a 2-port Insertion Loss measurement, both ends of the cable must be connected to the FieldFox.

**NOTE**

In high-loss conditions, a Cable Loss measurement becomes 'noisy' as the test signal becomes indistinguishable in the FieldFox noise floor. This can occur when measuring a very long cable and using relatively high measurement frequencies. To help with this condition, use High Power (page 57) and Averaging. (page 54).

---

### How to make a 1-port Cable Loss Measurement

1. Press **Preset** then **Preset**.
2. Then **More** then **Cable Loss (1-Port)**
3. Connect the cable to be tested.
4. Press **Freq/Dist** and enter **Start** and **Stop** frequency values of the measurement.
5. Press **Sweep 3** then **Min Swp Time**. Increase the Sweep Time until a stable trace is visible on the screen. The amount of time that is required increases with longer cable lengths. Learn more in the **Supplemental Online Help**: <http://na.support.keysight.com/fieldfox/help/SupHelp/FieldFox.htm>
6. Remove the cable to be tested.
7. Press **Cal 5**, then **Mechanical Cal**. Mechanical Cal.
8. Follow the prompts to perform calibration at the end of the jumper cable or adapter. Learn more about Calibration in "How to Perform a Calibration" on page 127
9. Connect the cable to be tested.

**NOTE**

Low-level standing waves (also known as 'ripple') which may be visible in reflection measurements, can hide the actual loss of the cable. Steps 10 through 13 can minimize the ripple. Perform the measurement with and without steps 10 through 13 and choose the method with the least amount of ripple.

---

10. Connect a LOAD at the end of the cable to be tested. This limits the reflections to faults that are located in the cable under test.
11. Press **Trace 6** then **Math and Memory** then **Data->Mem** to store the trace into Memory.
12. Remove the LOAD and leave the end of the cable to be tested open.
13. Press **Data Math** then **Data - Mem**. The ripple in the measurement is removed. These minor imperfections in the cable should not be considered in the Cable Loss measurement.

**14. Use Averaging to remove random noise from high-loss measurements.**  
Press **BW 2** then **Average**.

The displayed trace shows the Cable Loss values in one direction through the cable. A Return Loss measurement would show the loss for both down the cable and back. Therefore, a Cable Loss measurement is the same as a Return Loss measurement divided by 2.

The average Cable Loss across the specified frequency range is shown on the screen below the graticules.

## 2-Port Insertion Loss Measurements

A 2-port Insertion Loss measurement is used to measure the loss through a DUT (device under test) – or cable – over a specified frequency range. The FieldFox signal source is transmitted out the RF OUT connector, through the DUT, and into the RF IN connector. Both ends of the DUT must be connected to the FieldFox, either directly or indirectly using the cable used in the normalization cal.

‘Insertion’ loss simply means **loss** through a device, usually expressed in dB. It is exactly the same measurement as “S21 Transmission” in NA Mode.

### NOTE

**Exception:** In CAT mode, if the TDR data are saved in S1P format, the values represent the real part of the complex transform; the imaginary part is set to zero. To obtain complex data, either as real/imaginary or magnitude/phase pairs, use NA mode.

2-port Insertion Loss measurements are generally more accurate than 1-port Cable Loss measurements.

How to make a 2-port Insertion Loss Measurement

- Press **Mode** then **CAT**.
- Then **More** then **Insertion Loss (2-Port)**.
- Press **Freq/Dist** and enter **Start** and **Stop** frequency values of the measurement.
- Press **Sweep 3**, then select a **Resolution** setting.
- Press **Cal 5**, then perform a calibration. Learn more on “**How to Perform a Calibration**” on page 127.
- Connect the DUT and view the insertion loss measurement results.

When measuring very long lengths of cable, it may be necessary to increase the sweep time. Learn how on page 56. Learn why in the **Supplemental Online Help**: <http://na.support.keysight.com/fieldfox/help/SupHelp/FieldFox.htm>

## 4 DTF (Distance to Fault) Measurements

CAT Mode **Distance to Fault** (DTF) measurements are generally used to locate problems, or faults, in a length of cable or transmission line. In this chapter, the cable to be tested is referred to as the DUT (Device Under Test).

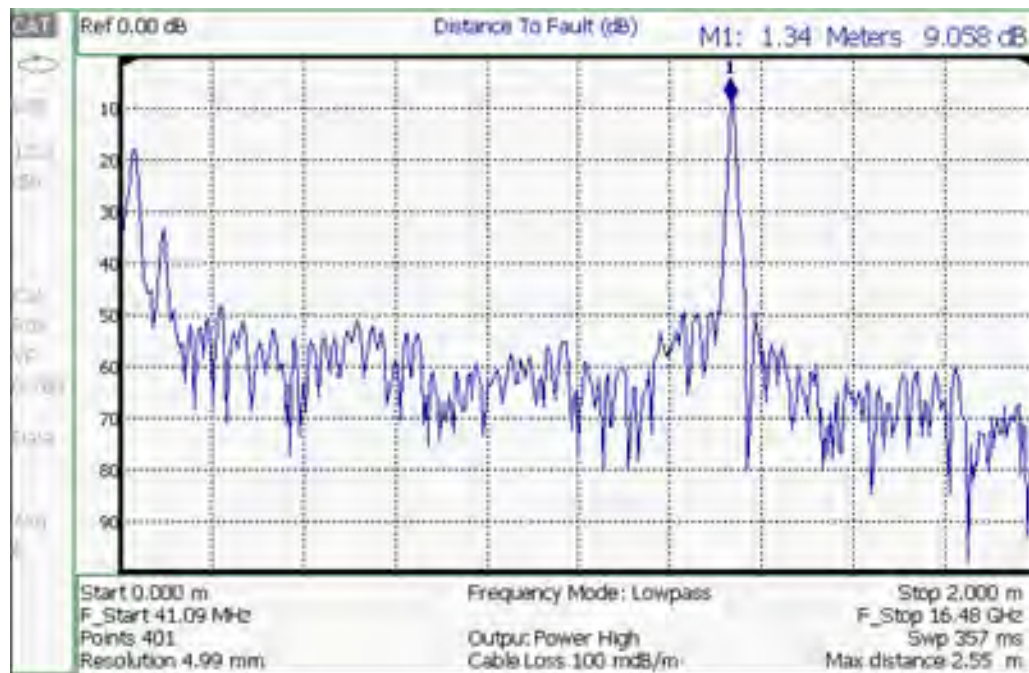

Settings that are NOT unique to DTF measurements are documented in the CAT Mode [Chapter 3, “CAT \(Cable and Antenna Test\) Mode.”](#)

### In this Chapter

[“How to make DTF Measurements” on page 64](#)

[“DTF Settings Table” on page 66](#)

[“DTF Measurement \(Format\)” on page 66](#)

[“DTF Start and Stop Distance” on page 67](#)

[“Frequency Mode” on page 67](#)

[“Coupled Frequency” on page 68](#)

[“Cable \(Correction\) Specifications” on page 69](#)

[“Window Settings” on page 72](#)

[“DTF Units” on page 73](#)

[“Calculated DTF values” on page 73](#)

[“About Alias Faults” on page 73](#)

### Optional settings

[“All about Markers” on page 700](#)

---

[“All about Limit Lines” on page 715](#)

---

[“Saving and Recalling Files” on page 778](#)

---

Trace Math is NOT available in DTF Measurements.

## How to make DTF Measurements

Before starting, you may need the following:

- Jumper cable or adapter to connect the beginning of the DUT to the FieldFox.
- LOAD with correct connector type and gender to terminate the end of the DUT (if possible).
- The known length and cable type of the DUT. If the cable type is not known, then the Cable Loss (dB/Meter) and Velocity Factor of the DUT are required.

1. Connect any necessary jumper cable or adapter to the FieldFox RF OUT port. Do NOT connect the DUT.
2. Press **Preset** then **Preset** to return the FieldFox to the default settings.
3. Then **Mode** then **CAT**.
4. Then **Meas 1** then **DTF**.
5. Press **Freq/Dist**, then **Stop Distance** and enter the length of the DUT. You can optionally set the Start Distance
6. Press **Cal 5** and follow the Cal prompts. Learn all about Calibration in [“How to Perform a Calibration” on page 127](#).
7. Disconnect any components or antenna that should NOT be measured and connect a LOAD at the end of the DUT.
8. Press **Meas Setup 4** then **DTF Cable Specifications**.

DTF (Distance to Fault) Measurements  
How to make DTF Measurements

9. Either press **Edit/Save/Recall Cables** then **Recall Cable**, or directly enter the Velocity Factor/Cable Loss of the DUT using the **Velocity Factor** and **Cable Loss** keys.
10. Connect the start end of the DUT to the FieldFox.
11. Press **Meas Setup 4** then **Settings** then **Next Page**. If the **Alias-free Range** setting is False, then you may see Alias faults on the screen. Learn more on [page 73](#).

## DTF Measurement Settings

### DTF Settings Table

You can set and view all of the DTF settings, including some calculated values, on the DTF Settings table. Learn about the calculated values in **“Calculated DTF values” on page 73**.

#### How to make settings on the DTF settings table

- Press **Meas Setup 4**.
- Then **Settings**.
- Press **Next Page** and **Previous Page** to view all settings.
- To change a setting:
  - Use the **▲▼** arrows or rotary knob to highlight a setting.
  - Numeric settings can be changed by pressing numbers using the numeric keypad. Then press Enter or select a suffix if available.
  - Other settings require you to press **Edit**, then press a softkey to change the value.
  - When finished changing a value, press **Done Edit**.
- Press **Dock Window** to relocate the Settings table to a position relative to the trace window. The setting persists through a Preset. Choose from the following:
  - **Full (Default setting)** Only the Settings table is shown on the screen. The trace window is temporarily not shown.
  - **Left** The Settings table is shown to the left of the trace window.
  - **Bottom** The Settings table is shown below the trace window.
- When finished changing ALL settings, press **Done** to save your settings.

### DTF Measurement (Format)

You can select from 3 different DTF Formats.

- Press **Measure 1**
- Then choose from:
  - **Distance to Fault (dB)** Faults are displayed on the Y-axis in return loss format, expressed as a positive number in dB.
  - **DTF (VSWR)** Faults are displayed on the Y-axis in SWR. Learn more about SWR at the FieldFox Supplemental Online Help: <http://na.support.keysight.com/fieldfox/help/SupHelp/FieldFox.htm>

## DTF (Distance to Fault) Measurements DTF Measurement Settings

- **More** then **DTF (Lin)** Faults are displayed on the Y-axis in linear (unitless) format.

### DTF Start and Stop Distance

In DTF measurements, you set the physical length of cable or other device to be tested. The FieldFox calculates the frequency range of the measurement from this distance. The longer the cable to be tested, the lower the frequencies that are used. You can also set the frequencies manually using the Frequency Mode [Bandpass] setting.

#### How to set Start and Stop Distance

- With a DTF measurement present, press **Freq/Dist**.
- Then choose from the following:
  - **Start Distance** Enter a value using the numeric keypad, the **▲▼** arrows, or the rotary knob, then **Enter**. By default, the Start Distance is set to 0 Meters. This means that the measurement will display faults starting at the point at which calibration standards are connected.
  - **Stop Distance** Enter a value between the start distance and 5 km (or 16,404 ft.) using the numeric keypad, the **▲▼** arrows, or the rotary knob, then **Enter**.

### Frequency Mode

All DTF measurements are made with frequency settings and, using Inverse Fourier Transform (IFT), the time and distance to faults are calculated.

#### NOTE

The start and stop frequencies for the measurement are always annotated on the screen below the start and stop distances.

#### How to set Frequency Mode

With a DTF measurement present,

- Press **Meas Setup 4**
- Then **Frequency Mode**
- Choose one of the following:
  - **Lowpass** The frequency range of a DTF measurement is set automatically based on the Start and Stop Distances. Use Lowpass mode when the DUT is a cable ONLY.

## DTF (Distance to Fault) Measurements DTF Measurement Settings

- **Bandpass** (Default setting) The frequency range of a DTF measurement is set manually. Use Bandpass mode when the DUT contains a diplexer or other filtering device which does not pass some frequencies.

Typically, you will set the frequency range of the measurement to the passband of the filter. However, you may also want to test the ability of the filter to reject unwanted frequencies. In this case, set the frequency range to include those frequencies which the filter may not be adequately rejecting.

### How to manually set Frequencies in Bandpass Mode

- Press **Freq/Dist**
- Then **Min Start Freq** and type the start frequency to use for the DTF measurement.
- Then **Max Stop Freq** and type the stop frequency to use for the DTF measurement.
- OR
- Press **More**
- Then **Max Freq Span** and type the frequency range to use for the DTF measurement.
- Then **Center Frequency** and type the center frequency of the range to use for the DTF measurement.

When the DTF frequencies are set manually, they may not be the optimum frequencies for measuring the distance to fault. The distance may no longer be alias-free. Learn more about alias-free range on [page 73](#).

These settings specify the minimum and maximum frequencies to be used for the DTF measurement. These exact frequencies may not be used, but a narrower frequency range may be used that will still pass through the bandpass filter.

## Coupled Frequency

When a Return Loss & DTF measurement is present, this setting allows you to have different frequency ranges for each measurement. Learn more in [“Coupled Frequency” on page 58](#).

## Cable (Correction) Specifications

By default, the FieldFox does NOT correct DTF measurements to account for the inherent loss of a cable. However, to make more accurate DTF measurements, the Cable Loss and Velocity Factor values should be considered.

### NOTE

The following describes Coax Media type. However, you can create or edit Waveguide Media Standards. Learn how in [“Waveguide Calibrations” on page 139](#).

---

### About Velocity Factor and Cable Loss

- Velocity Factor is a property of the physical material of a cable. A VF of 1.0 corresponds to the speed of light in a vacuum, or the fastest VF possible. A polyethylene dielectric cable has VF = 0.66 and a cable with PTFE dielectric has VF = 0.7.
- Cable Loss is specified in dB/meter. In addition to the length of the cable, loss is also directly proportional to the frequency of the signal that passes through the cable.

The following is an example showing how DTF cable correction works:

The DUT is a 100 meter transmission cable. The Cable Loss value is 0.1 dB/meter. This means that a signal traveling ONE WAY through the cable will lose 10 dB of power (100 m \* 1 dB/m). Because the FieldFox performs this measurement with 1 port, the test signal travels down the cable and then back, for a total loss of 20 dB.

After a calibration has been performed, for the purpose of illustrating this point, connect an OPEN to the end of the cable – a maximum-sized fault – for 100% reflection of the 300 MHz test signal.

**Without compensation** for the loss of the cable, a –20 dB response would be visible at 100 meters, which is the OPEN at the end of the DUT. This is from 10 dB of loss through the cable in each direction.

**With compensation** for the loss using the manufacturer’s specification, the FieldFox compensates the trace as though the signal traveling through 100 meters was increased by +20 dB. Therefore the response will show 0 dB for 100% reflection.

### How to enter Cable Loss and Velocity Factor

Cable Loss and Velocity factor can be entered using one of the following methods:

- Manually enter cable loss and velocity factor for the measurement.
- Select or create a cable file which contains the cable loss and velocity factor.

With a DTF measurement present:

## DTF (Distance to Fault) Measurements

### DTF Measurement Settings

- Press **Meas Setup 4**.
- Then **DTF Cable Specifications**
- Select **Cable Corr**
  - **Auto** Use Cable Loss and Velocity Factor values from a Cable file. See “How to Edit, Save, and Recall a Cable File” below. This will overwrite a manually-entered value.
  - **Man** (Default setting) Manually enter a value for Cable Loss and Velocity Factor.
- Then:
  - **Velocity Factor** Using the numeric keypad, enter a value between 0.01 and 1. Then press **Enter**.
  - **Cable Loss** Using the numeric keypad, enter a positive Cable Loss value in dB/m, then press **Enter**.

### How to Edit a Cable File

The FieldFox includes many predefined cable files with the manufacturer's specifications. You can edit these files or create new cable files using the following procedure or using the FieldFox Data Link Software.

The Cable correction data survives a Mode Preset and Preset.

With a DTF measurement present:

- Press **Meas Setup 4**
- Then **DTF Cable Specifications**
- Then **Edit/Save/Recall Cables**
- Press **New Cable** then **Yes** to clear all data from the existing DTF Cable table and reset header information to default settings.
- Then **Edit Cable** to open the Cable Editor.
- Then use the **▲▼** arrows to select a field,
  - When editing Cable Description information, press **Edit** then modify the selected field using the FieldFox labeler.
  - When editing Frequency/Loss pairs, enter numbers using the numeric keypad, then select a frequency suffix. Then **Enter**. Learn more about “How the Freq/Loss pairs are applied” below.
- Optionally choose from the following:
  - **Previous / Next Page** Quickly scrolls through pages of Freq/Loss data.
  - **Add Data** Add a blank Freq/Loss pair to the table,

- **Delete/Clear** then:
- **Delete Row** Remove the selected Freq/Loss pair from the table.
- **Clear All** then **Yes**. Remove all Freq/Loss pairs from the table and resets header information
- Press **Done** to close the Cable Editor.

### How to Save or Recall a Cable

- Press **Save Cable** to save your changes to the specified Storage Device. Enter a filename using the FieldFox labeler (learn more on [“How to use the FieldFox labeler ” on page 780](#)). Learn more about Cable files below.
- Press **Recall Cable** to load a Cable file from the specified Storage Device
- **Storage Device** Changes the device used to save or recall Cable files. This is a different setting from the Save/Recall Storage Device setting. Choose from Internal (default setting), **USB** (must be connected) or **SD card**.

### About Cable files

- Cable files are saved to, and recalled from, the **Cables** folder. If the folder does not already exist on a USB or SD card, it is created automatically before storing the file.
- Cable files are stored as \*.xml files. Existing cable files that are preloaded into the FieldFox firmware can be overwritten. Your edited file will NOT be overwritten when firmware is updated.
- To **DELETE** a Cable file, use the Manage Files feature. Learn more in [“Manage Files” on page 786](#).

### How the Freq/Loss pairs are applied

When the cable file contains one Freq/Loss pair, that correction value is applied to the entire displayed frequency span.

When the cable file contains two or more Freq/Loss pairs, the Loss value that is used is interpolated from the Freq/Loss pairs and the DTF center frequency. For example, using a cable file with the following Freq/Loss pairs:

1 GHz: 0.1 dB/m  
2 GHz: 0.2 dB/m

The center frequency for the measurement is determined from the calculated (Stop – Start) frequency values (seen on the second page of DTF Settings):

Calculated Start = 2.0 MHz

Calculated Stop = 3.598 GHz

Center Freq = 1.80 GHz

The Loss value for the measurement is interpolated from the Freq/Loss pairs at the Center Freq:

1 GHz = 0.1 dB/m

1.8 GHz = 0.18 dB/m

2 GHz = 0.2 dB/m

The correction for loss at 5 meters in one direction:  $0.18 \text{ dB/m} * 5\text{m} = 0.9 \text{ dB}$ .

All DTF measurements correct for loss for travel down the DUT and back, so double the correction:  $0.9 \text{ dB} * 2 = 1.8 \text{ dB}$ .

## Window Settings

Window settings provide the ability to choose between optimizing DTF measurements for resolving closely-spaced faults or for the ability to measure low-level faults.

### How to select Window settings

- Press **Meas Setup 4**.
- Then **Settings**.
- Then press **▲▼** arrows to move to the Window row.
- Then press **Edit**.
- Then press **Window** and choose from the following:
  - **Maximum (Maximum – Optimized for dynamic range)** the noise floor is lowered to provide the ability to measure low-level responses. (Default setting)
  - **Medium** – Compromise between Minimum and Maximum window settings.
  - **Minimum** – Best Response Resolution, providing the ability to resolve between two closely-spaced responses.
- Then press **Done Edit**.
- Again press **Done**.

## DTF Units

The DTF Units setting is available ONLY on the DTF Settings table.

By default, X-axis units for DTF measurement settings are displayed in Meters.

### How to change DTF units

- With a DTF measurement present, press **Freq/Dist**.
- Then **More** then **Distance Unit m feet**.
- The current selection is underlined **m (meters) Feet**.

## Calculated DTF values

Press **Next Page** on the DTF Settings Table to view the following **calculated Values** noted on the FieldFox screen with c - <setting>

**Start Frequency** – Start frequency that is used to calculate DTF.

**Stop Frequency** – Stop frequency that is used to calculate DTF.

**Range Resolution.** Indicates the accuracy of the distance to fault measurement. For example, with range resolution of 500 mm, if the distance to fault is 10 meters, this value could be inaccurate by +/- 500 mm or between 9.5 to 10.5 meters. This value is calculated from frequency span / resolution (points).

Response Resolution, not displayed, indicates the distance that could be between two faults and still show as separate faults. Learn more in **“Window Settings” on page 72**.

**Maximum Distance.** The distance that could be viewed with the current settings. Defined by:  $V_f * c * \text{Points} / (2 * \text{Bandwidth})$  where:

- $V_f$  = velocity factor
- $c$  = speed of light
- Points = resolution
- Bandwidth = frequency range

Alias-free Range (On/Off)

- On = No Alias images
- Off = Alias images may appear in the response.

## About Alias Faults

An alias fault is not a true device response. An alias fault appears because of the method used to convert frequency to time.

On the DTF Settings page (above) the c - Alias-free Range = Off setting indicates alias images MAY appear on the screen.

Shorter stop distances (less than 10 meters) and a higher resolution (1001 points) will be **more** likely to result in **Alias-free Range = Off**.

When the Alias-free Range = Off, the following procedure will help to determine if a response is true or an alias response:

- 1. Put a marker on the response in question and note the distance to the fault.**
- 2. Change the start or stop distance.**

A true fault response will not move in distance. That is, if a true fault is present at 10.3 meters, changing the stop distance from 15 m to 20 m will not move the fault; the fault will remain at 10.3 meters. However, an alias response will appear to move.

An un-terminated cable (with NO perfect load at the end) will show faults that appear to be beyond the end of the cable. These are NOT alias faults. These faults appear as the signal reflects off the open at the end of the cable and travels back down the cable toward the connection at the FieldFox.

Re-reflections are measured at the FieldFox as mirror images of the original faults. The largest fault is the open end of the cable. To avoid confusion, set the Stop distance shortly after that fault.

## 5 NA (Network Analyzer) Mode

Learn more about NA Mode measurements in the FieldFox Supplemental Online Help:

<http://na.support.keysight.com/fieldfox/help/SupHelp/FieldFox.htm>.

### In this Chapter

- “About S-parameters” on page 91
- “Mixed-Mode S-Parameters” on page 92
- “Parameter Conversion” on page 93
- “Receiver Measurements” on page 94
- “Multi-Trace Configurations” on page 95
- “Quick Settings” on page 96
- “Calibration Settings” on page 97
- “Format” on page 98
- “Frequency Range” on page 99
- “Scale Settings” on page 99
- “Magnitude Offset” on page 100
- “Electrical Delay” on page 101
- “Phase Offset” on page 101
- “Averaging” on page 102
- “IF Bandwidth” on page 103
- “Smoothing” on page 103
- “Single or Continuous Measure” on page 104
- “Resolution (Number of Data Points)” on page 104
- “Sweep Time” on page 105
- “Output Power” on page 107
- “System Impedance (Z0)” on page 108

“Port Extensions” on page 108

“Velocity Factor” on page 109

“Increase Dynamic Range” on page 112

### **See Also**

“Why and When to Calibrate” on page 126

“All about Markers” on page 700

“All about Limit Lines” on page 715

“All about Trace Math” on page 720

Learn how to make 75Ω (ohm) Measurements in the Supplemental Online Help:

<http://na.support.keysight.com/fieldfox/help/SupHelp/FieldFox.htm>

## NA Mode Settings

Select NA Mode before making any setting in this chapter.

How to select NA Mode

- Press **Mode**.
- Then **NA**.

### About S-parameters

S-parameters (scattering parameters) are used to describe the way a device modifies a signal. The FieldFox can measure **four S-parameters**. The syntax for each parameter is described by the following:

S (out | in)

**out** = FieldFox receiver port

**in** = FieldFox source port

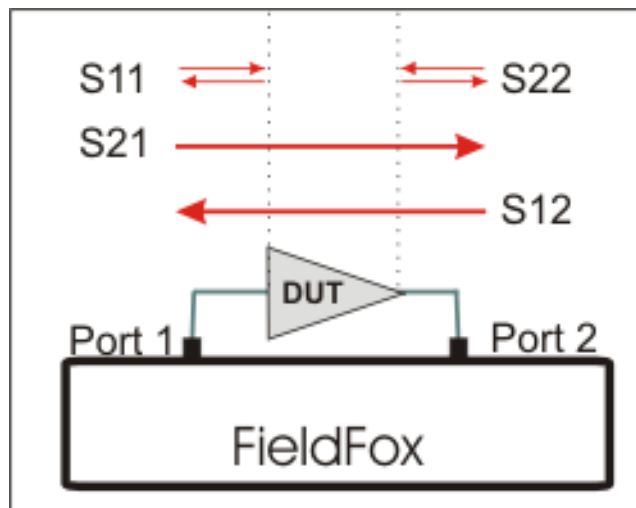

The FieldFox automatically switches the internal source and receivers to make both forward and reverse measurements. Therefore, the FieldFox can measure all four S-parameters with a single connection

When the source comes from port 1, the measurement is said to be in the forward direction

When the source comes from port 2, the measurement is said to be in the reverse direction

S11 and S22 reflection measurements are used to measure the amount of reflections off the corresponding DUT port. Low reflections means there is a good impedance match between the source and DUT.

S21 and S12 transmission measurements are used to measure the loss or gain through a DUT over a specified frequency range. Both ends of the DUT must be connected to the FieldFox. The FieldFox signal source is transmitted out one of the test port connectors, through the DUT, and into the other test port connector

### How to measure S-parameters

1. Press **Preset** then **Mode Preset (Factory)**
  2. Press **Measure 1** then choose from the following:
    - **S11** Reflection measurement at port 1.
    - **S21** Forward 2-port transmission measurement.
    - **S12** Reverse 2-port transmission measurement. May require an option.
    - **S22** Reflection measurement at port 2. May require an option.
- OR** select a multi-trace configuration. Learn more on [“Multi-Trace Configurations” on page 95](#)
3. Press **Freq/Dist** then either **Start** and **Stop** or **Center** and **Span** to enter a Frequency Range for the measurement.
  4. Press **BW 2** then **IFBW** to select the IF Bandwidth for the measurement. Narrower bandwidths require more time to sweep, but lowers trace noise.
  5. Press **Sweep 3** then **Resolution** to select the number of data points for the measurement. More data points require more time to sweep.
  6. Press **Cal 5** to calibrate the measurement. Learn more in [“How to Perform a Calibration” on page 127](#).
  7. All other settings can be made AFTER calibration without compromising measurement accuracy.

### Mixed-Mode S-Parameters

In NA Mode ONLY, mixed-mode S-parameters (also known as Balanced measurements) are available with Option 212.

Because the FieldFox has only two test ports, only reflection measurements are available. Connect the balanced input or output of your DUT to the FieldFox ports 1 and 2

For highest accuracy, a Full 2-port calibration is required.

All FieldFox settings and features are supported (except Parameter Conversion) with mixed-mode S-parameters.

**NOTE**

Learn more about Balanced Measurements with the FieldFox in the FieldFox Supplemental Online Help:

<http://na.support.keysight.com/fieldfox/help/SupHelp/FieldFox.htm>

---

### How to make mixed-mode S-parameter measurements

- Press **Measure 1**.
- Then **More**.
- Then choose from the following:
  - **Sc11** Common reflect/common incident for logical port 1.
  - **Sdd11** Differential reflect/differential incident for logical port 1.
  - **Sdc11** Differential reflect/common incident for logical port 1.
  - **Scd11** Common reflect/differential incident for logical port 1.

To make balanced reflection measurements at the DUT output, connect the DUT output to the FieldFox ports.

### Parameter Conversion

In NA Mode ONLY, converts the active S-parameter trace to an equivalent impedance (Z), admittance (Y), or reciprocal 1/S-parameter

How to select parameter conversions

- Press **Measure 1**
- Then select an S-parameter
- Then **More**
- Then **Conversion**
- Then choose from the following:
  - **Off** (default) No conversion is performed.
  - **Z Conv (--)** or **Y Conv (--)** Perform conversion for impedance (Z) or admittance (Y). Then choose from the following for either:
    - **Auto** The displayed S-parameter is converted to the appropriate Z or Y parameter: Refl for S11 and S22; Trans for S21 and S12. When the S-parameter is changed, the appropriate conversion changes automatically.
    - **Refl** The displayed S-parameter is converted to Z or Y reflection, regardless of whether the S-parameter is reflection (S11 or S22) or transmission (S21 or S12).

- **Trans** The displayed S-parameter is converted to Z or Y transmission, regardless of whether the S-parameter is reflection (S11 or S22) or transmission (S21 or S12).
- **1/S** The displayed S-parameter is converted to 1/S-parameter.

## Receiver Measurements

In NA Mode ONLY, you can make unratioed, uncorrected receiver measurements. These measurements are typically used as diagnostic tools for service personnel.

### NOTE

Receiver measurements are NOT corrected for absolute power. They are only useful for making relative measurements. The Y-Axis and markers are labeled in dB - NOT dBm. Specifically, R1 and R2, do NOT indicate the actual power levels out of the source ports.

### How to make receiver measurements

- Press **Measure 1**
- Then **More**, then **Advanced**
- Then choose from the following:

**A** Port-1 test port (\*1)

**B** Port-2 test port (\*2)

**R1** Port-1 reference receiver (\*1)

**R2** Port-2 reference receiver (\*2)

(\*) indicates the Auto-selected source port for the measurement

**Source Port** The FieldFox port to provide the source signal. Choose from the following:

- **Auto** The FieldFox sets the source port based on the selected receiver.
- **Port 1** Select when measuring transmission at B receiver.
- **Port 2** Select when measuring reverse transmission at A receiver.

Learn more about Raw Receiver Measurements at the FieldFox Supplemental Online Help:

<http://na.support.keysight.com/fieldfox/help/SupHelp/FieldFox.htm>

## Multi-Trace Configurations

In NA Mode you can display multiple traces on the FieldFox screen.

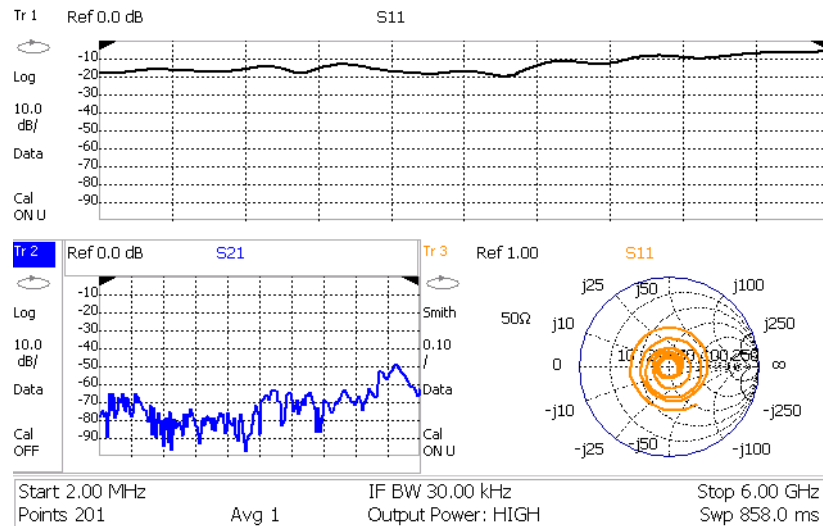

The graphic above shows a x3H configuration. Tr2 is the ACTIVE trace as indicated by the highlighted **Tr2**.

### Trace Setting Notes

- The Frequency Range, IF BW, Resolution, Average, and Output Power settings are common for all displayed traces.
- All other trace settings, such as measurement, format, and limit lines, are applied individually to the ACTIVE trace in the same manner as when a single trace is present.







#### NOTE

**IMPORTANT!** For CAT and NA modes, limit lines do not apply where  $F1 = F2$ .

- By default, a marker is created on ALL traces. However, they can be created individually by disabling Coupled Markers. Learn more in [“Coupled Markers \(NA Mode\)” on page 703](#).

### How to select a multi-trace configuration

- Press **Trace 6**
- Then **Num of Traces**
- Then choose from the following:  
The default measurements depend on the options that are installed

	<b>x1</b>	1 trace standard configuration
	<b>x2</b>	2 traces overlaid on a single graticule
	<b>x2H</b>	2 traces on separate graticules
	<b>x3H</b>	3 traces on separate graticules
	<b>x3</b>	3 traces overlaid on a single graticule
	<b>x4</b>	4 traces overlaid on a single graticule
	<b>x4H</b>	4 traces on separate graticules

### How to activate a trace in order to change a setting

- Use the  arrows **OR**
- Press **Trace 6** then select **Trace 1**, **Trace 2**, **Trace 3**, or **Trace 4**. Only traces that are shown can be activated.

### How to maximize the viewing of the active trace

- Press **System 7**
- Then **Full Screen**.
- Press any key to return to the standard display.

## Quick Settings

Both CAT and NA Modes allow you to view and change most relevant settings from a single location. All of these settings are discussed in this chapter and, unless otherwise noted, ALL of these settings can also be made using the standard softkey menus.

### How to view and change Quick Settings

- Press **Meas Setup 4**
  - Then **Settings**.
  - Press **Next Page** and **Previous Page** to view all settings. If these softkeys are NOT available, then all available settings fit on one page.
  - To change a setting:
    - Use the **▲▼** arrows to highlight a setting.
    - Then press **Edit**. The current setting changes to **yellow**.
    - Some settings require you to press a softkey to change the value. Otherwise, use the numeric keypad, **▲▼** arrows, or rotary knob to change the value.
    - When finished changing a value, press **Done Edit**.
  - Press **Dock Window** to relocate the Settings table to a position relative to the trace window. The Dock Window setting persists through a Preset. Choose from the following:
    - **Full (Default setting)** Only the Settings table is shown on the screen. The trace window is temporarily not shown.
    - **Left** The Settings table is shown to the left of the trace window.
    - **Bottom** The Settings table is shown below the trace window.
- When finished changing ALL settings, press **Done** to save your settings.

### Calibration Settings

NA Mode has a page specifically for making settings that pertain to Port Extensions, including Velocity Factor and Media Type.

Learn more in **“Port Extensions” on page 108**.

Learn more about Media Type in **“Waveguide Calibrations” on page 139**.

See also, **Chapter 8 “Calibration for NA, CAT, and VVM Modes”** and to **“Apply Nearest (NA Mode Only)” on page 144**.

### How to view and change Calibration Settings

- Press **Meas Setup 4**.
- Then **Calibration Settings**
- Make these settings in the same manner as Quick Settings in the previous section.

## Format

Select the display format in which to present measurement results. This setting can be changed at any time without affecting calibration accuracy.

### NOTE

Learn more about Display Formats in the FieldFox Supplemental Online Help:

<http://na.support.keysight.com/fieldfox/help/SupHelp/FieldFox.htm>

The marker on screen readout can be changed to formats other than the display format. Learn more in “[Marker Format](#)” on page 705.

### How to select a NA Format

- Press **Measure 1**.
- Then **Format [current setting]**.
- Then choose from the following:
  - **Log Magnitude** Displays magnitude in dB
  - **Linear** Displays positive values only. Y-axis: Unitless (U) for ratioed measurements; Watts (W) for unratioed measurements.
  - **VSWR** Used mainly for S11 and S22. Displays unitless reflection data.
  - **Phase** Displays phase in degrees. The trace ‘wraps’ every 360 degrees, from +180 to –180, for easy scaling.
  - **Smith** Used mainly for S11 and S22, which are plotted on a Smith Chart. Displays series resistance and reactance.
  - **More** then...
  - **Polar** Used mainly for S11 and S22. Displays magnitude and phase of the reflection coefficient.
  - **Group Delay** Used mainly for S21 and S12. Displays signal transmission (propagation) time through a device in seconds. The Group Delay aperture is the current Smoothing aperture. Default is 1.5% of the X-axis.
    - Learn how to set Smoothing aperture on “[Smoothing](#)” on page 103.
    - Learn more about Group Delay measurements at the FieldFox Supplemental Online Help:  
<http://na.support.keysight.com/fieldfox/help/SupHelp/FieldFox.htm>
  - **Real** Displays only the real (resistive) portion of the measured complex data. The Y-axis is Unitless. Often used for Time Domain measurements.

- **Imaginary** Displays only the reactive portion of the measured complex data. The Y-axis is Unitless.
- **Z Magnitude** Displays the effective impedance in ohms.
- **Unwrap Phase** Same as Phase, but without 180 degree wrapping.

## NOTE

Phase is unwrapped by comparing the phase from one data point to the next. If the phase difference between two data points is greater than 180 degrees, or if the phase of the first data point is greater than 180 degrees from DC, then the phase measurement is probably NOT accurate. To ensure that the phase measurement is accurate, increase the resolution setting. When making a narrow band measurement, reduce the start frequency for the unwrapped phase measurement to ensure the first data point is less than 180 degrees from DC.

## Frequency Range

Set the range of frequencies over which you would like to make measurements.

When the frequency range is changed after a calibration is performed, the cal becomes interpolated. Learn more in [“Interpolation \\*” on page 142](#).

### How to set Frequency Range

This can be done in two ways:

- Press **Freq/Dist**
- Then choose from the following:
  - **Start** and **Stop** frequencies – Specify the beginning and end of the sweep.
  - **Center** and **Span** frequencies – Specify the center frequency and span of frequencies (half on either side of center).
- Follow each by entering a value using the numeric keypad, the **▲▼** arrows, or the rotary knob.
- After using the **▲▼** arrows or the rotary knob, press **Enter**. The increment setting of the arrows is based on the current span and can NOT be changed in NA Mode.
- After using the keypad, select a multiplier key. Learn more in [“Multiplier Abbreviations” on page 46](#).

## Scale Settings

Adjust the Y-axis scale to see the relevant portions of the data trace. The Y-axis is divided into 10 graticules.

This setting can be changed at any time without affecting calibration accuracy.

### How to set Scale

- Press **Scale / Amptd**.
- Then choose from the following method
  - **Autoscale** Automatically adjusts the Y-axis to comfortably fit the Minimum and Maximum amplitude of the trace on the screen.
  - **Autoscale All** Autoscales all of the traces on the screen, useful only for multi-trace configurations.
- 3. Set Scale, acquisition, and Reference Position
  - **Scale** Manually enter a scale per division to view specific areas of the trace.
  - **Ref Level** Manually set the value of the reference line. Enter a negative value by pressing **Run/Hold (+/-)** either before or after typing a value.
  - **Ref Pos** Manually set the position of the reference line. Values must be between 0 (TOP line) and 10 (BOTTOM line)

### Scale annotation on the FieldFox screen

- Reference Line = red arrow
- Ref Level = -40 dB
- Ref Position = 1
- Scale = 2 dB per division

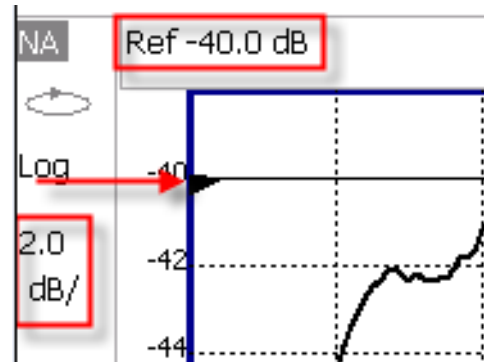

## Magnitude Offset

Magnitude Offset allows you to offset the magnitude (not phase) data by a fixed and/ or sloped value in dB. If the display format is Linear Magnitude or Real (unitless), the conversion from dB is performed and the correct amount of offset is implemented.

The Magnitude offset setting affects only the active trace.

### How to set Magnitude Offset

- Press **Scale / Amptd**
- Then **More**
- Then **Magnitude Offset** - Offsets the entire data trace by the specified value.

- Then enter a positive or negative offset value in dB using the numeric keypad, the **▲▼** arrows, or the rotary knob. Press a multiplier key. Learn about multiplier abbreviations.
- And/or press **Slope** - Offsets the data trace by a value that changes linearly with frequency. The offset slope begins at 0 Hz. and continues to the stop frequency. The offset value at the start frequency is then calculated from 0 Hz.
- Then enter a positive or negative offset slope value in dB/GHz using the numeric keypad, the **▲▼** arrows, or the rotary knob. Press a multiplier key. Learn about multiplier abbreviations in **“Multiplier Abbreviations” on page 46.**

## Electrical Delay

Electrical delay is a mathematical function that simulates a variable length of lossless transmission line. Use the electrical delay feature to compensate for the linear phase shift through a device and view only the deviation from linear phase of the device.

You can set the electrical delay independently for each measurement trace. To apply an electrical delay to all measurement traces, use Port Extensions. Learn how in **“Port Extensions” on page 108.**

Learn how to set Phase formats in **“Phase Offset” on page 101.**

### How to set Electrical Delay

- Press **Scale / Amptd**
- Then **More**
- Then **Electrical Delay**
- Enter a time value using the numeric keypad, the **▲▼** arrows, or the rotary knob.
- Press a multiplier key. Learn about multiplier abbreviations in **“Multiplier Abbreviations” on page 46.**

Electrical Delay can also be set using the **Mkr->Delay** feature. Learn how on **“Marker Functions” on page 713.**

## Phase Offset

Phase offset mathematically adjusts the phase measurement by a specified amount, up to 360°. Use this feature in the following ways:

**Improve the display of a phase measurement.** This is similar to the way you would change the acquisition in an amplitude measurement. Change the phase response to center or the response on the screen.

**Emulate a projected phase shift in your measurement.** For example, if you know that you need to add a cable and that the length of that cable will add a certain phase shift to your measurement, you can use phase offset to add that amount and simulate the complete device measurement.

You can set the phase offset independently for each measurement trace.

#### How to set Phase Offset

- Press **Scale / Amptd**
- Then **More**
- Then **Phase Offset**
- Enter a value in degrees using the numeric keypad, the **▲▼** arrows, or the rotary knob. Press **Enter**

## Averaging

Averaging helps to reduce the effects of random noise on a measurement. You specify the number of measurements to be averaged. The more measurements averaged, the greater the amount of noise reduction. An average counter is shown in the left edge of the screen as Avg <n> where <n> is the number of measurements that are averaged.

Averaging can be set before or after calibration. When set before calibration, each calibration standard is measured <n> times and averaged. More time is needed to perform the calibration, but there will be less noise in the resulting error terms which means that subsequent measurements will also have less noise. In addition, noise is further reduced by continuing to average after calibration.

#### How to set Averaging

- Press **BW 2**.
- Then **Average <n>** where <n> is the number of measurements to average.
- Enter a value using the numeric keypad. Enter 1 for NO averaging.
- Press **Enter**.
- Then **Average Mode** Choose from the following:
  - **Sweep** - Each data point is based on the average of the same data point being measured over <n> consecutive sweeps. The average counter shows the number of previous sweeps that have been averaged together to form the current trace. When the counter reaches the specified count, then a 'running average' of the last <n> sweeps is displayed.

- **Point** - Each data point is measured <n> times and averaged before going to the next data point. On subsequent sweeps, averaging restarts by measuring each data point again <n> times. The average counter is not updated because data is not displayed until all the averages have been applied.
- **Point averaging is usually faster than sweep averaging.** However, you may need to increase the Point Average count to obtain the same level of noise reduction as with sweep averaging.
- While averaging is in process, press **Sweep 3** then **Restart** to restart the averaging at 1.

## IF Bandwidth

The FieldFox converts the received signal from its source to a lower intermediate frequency (IF). The bandwidth of the IF bandpass filter is adjustable. Reducing the IF receiver bandwidth reduces the effect of random noise on a measurement. However, narrower IF bandwidths cause longer sweep times.

### How to set IF BW

- **Press BW 2.**
- Then **IF BW**
- Then choose from the following:
- **10 Hz | 100 Hz | 1 kHz | 10 kHz | 100 kHz**  
**More 30 Hz | 300 Hz | 3 kHz | 30 kHz**

## Smoothing

Trace smoothing averages a number of **adjacent** data points to smooth the peak-to-peak noise values on a displayed trace. The number of adjacent data points that are averaged is known as the smoothing aperture. Aperture is set by specifying a percentage of the X-axis span.

Trace smoothing does NOT significantly increase measurement time.

Smoothing is used in Group Delay measurements, although it can be used with any NA format EXCEPT Polar or Smith Chart. Learn more about NA Mode formats, including Group Delay, in **“Format” on page 98**.

When enabled, **Smo** appears on the FieldFox screen.

### How to set Smoothing

- **Press BW 2**
- Then **Smoothing ON OFF**
- Then **Sm. Aperture** and enter a value between 0 and 25 (percent) using the numeric keypad.

- Press **Enter**

## Single or Continuous Measure

This setting determines whether the FieldFox sweeps continuously or only once each time the **Single** button is pressed. Use Single to conserve battery power or to allow you to save or analyze a specific measurement trace.

This setting can be changed at any time without affecting calibration accuracy.

### How to set Single or Continuous

- Press **Sweep 3**.
- Then choose one of the following:
  - **Single** Automatically sets Continuous OFF and causes FieldFox to make ONE sweep, then hold for the next Single key press. Hold is annotated in the upper left corner of the display when NOT sweeping, and changes to an arrow --> while the sweep occurs.
  - **Continuous** Makes continuous sweeps. This is the typical setting when battery power is not critical.
- You can also use **Run / Hold +/-** to toggle between Single and Continuous.

## Resolution (Number of Data Points)

Data points are individual measurements that are made and plotted across the X-axis to form a trace. Select more data points to increase measurement resolution. However, more data points also takes more time to complete an entire measurement sweep.

When the Resolution is changed after a calibration is performed, the cal becomes interpolated. Learn more in **“Interpolation \*” on page 142**.

### How to set Resolution

- Press **Sweep 3**.
- Then **Resolution**.
- Then choose from the following:  
**101** | **201** | **401** | **601** | **801** | **1001** | **1601** | **4001** | **10001**.
- Using SCPI, Resolution can be set to ANY number of points between 3 and 10001. See the Programming Guide at <http://na.support.keysight.com/fieldfox/help/Programming/webhelp/FFPprogrammingHelp.htm>

## Sweep Time

The fastest possible sweep time is always used as the default setting. Use the Min Swp Time setting to slow the sweep time when measuring long lengths of cable. Learn more at the FieldFox Supplemental Online Help:

<http://na.support.keysight.com/fieldfox/help/SupHelp/FieldFox.htm>

The actual sweep time is shown on the FieldFox screen. See the Screen Tour on **“Screen Tour” on page 44**. To increase the sweep time, enter a value that is higher than the actual sweep time. The increase will not be exactly the amount that you enter, as the actual sweep time is the composite of many factors.

### NOTE

Measurement speed specifications do NOT apply in Temperature Control Mode. Learn more in **“Temperature Control Mode” on page 33**.

### How to set Sweep Time

- Press **Sweep 3**.
- Then **Min Swp Time**.
- Enter a value using the numeric keypad.
- Press a multiplier key. Learn about multiplier abbreviations in **“Multiplier Abbreviations” on page 46**.

## Triggering

External triggering (NA and SA modes ONLY) allows you to initiate a sweep when an external DC voltage is sensed at the Ref In/Trig In connector on the FieldFox top panel. See External Triggering for SA Mode in **“Triggering” on page 192**.

### Trigger Source

- Press **Sweep 3**
- Then **Trigger**
- Then **Trig Source**
- Then choose from the following:
  - **Int** (Internal) Sweeps are initiated by the FieldFox internal circuitry. When Sweep is set to Continuous, a new sweep begins automatically when the previous sweep ends.
  - **Ext** (External) A sweep is initiated on the rising or falling edge of an external TTL signal at the Ref In/Trig In connector on the FieldFox top panel.
    - When the FieldFox is armed for an external trigger signal, **Wait** is annotated on the display.

- A sweep can NOT be initiated by an external signal while a sweep is in progress.
- A sweep can NOT be initiated by an external signal when in HOLD mode. Learn more about HOLD mode in.
- **Pnt** (Point) An external trigger type that acquires exactly one point per trigger input.

**CAUTION**

**IMPORTANT!**

If trigger signals come faster than the FieldFox can process them, some triggers may be ignored or lost.

---

**NOTE**

To ensure triggers are recognized and processed in order, use the external trigger output function to indicate when the FieldFox is ready for another input trigger. Alternatively, slow the external triggers coming in from external equipment to a rate where FieldFox does not miss a trigger.

The External Trigger output signal is only selectable when Point Mode Trigger is enabled. Not supported in other trigger modes.

External Trigger output signal is sent as soon as FieldFox has processed the last trigger signal that was detected.

As each point is acquired, the data will show up on screen. If a trigger has not been detected, a yellow **Wait** indicator will show on the sweep status icon area.

---

- When the FieldFox is armed for an external trigger signal, **Wait** is annotated on the display.
  - A sweep can NOT be initiated by an external signal when in HOLD mode. Learn more about HOLD mode in.

### Error Handling and Recovery

- Point Mode trigger is not compatible with sweep setups that require forward and reverse sweeps such as:
  - Full 2port cal
  - Cal ready (Full 2Port)
  - Multiple displayed parameters that include the requirement for forward and reverse sweeps such as S11 and S22 together on the display
- When point mode trigger is already enabled, if conditions are changed requiring forward and reverse sweeps, an error "Error: Point trigger not compatible with 2-port cal." will be displayed and point mode

trigger will revert to Internal trigger. This includes turning on a CAL that requires forward and reverse sweeps or displaying multiple parameters that would require forward and reverse sweeps.

- If the FieldFox is in a state requiring two sweeps and the user selects point mode triggering, an error "Error: Point trigger not compatible with 2-port cal." will be displayed and point mode trigger will revert to Internal trigger.

### Trigger Slope

Determines which edge of an External trigger signal initiates a sweep.

- Press **Sweep 3**
- Then **Trigger**
- Then **Trig Slope**
- Then choose from the following:
  - **Positive** Sweep is initiated by the rising edge of signal at about 1.7 V.
  - **Negative** Sweep is initiated by the falling edge of signal at about 1.0 V.

## Output Power

Set the power level out of the FieldFox to High, Low, or manually set power level to a value between High and Low.

Generally, the high power setting is used when measuring passive, high-loss devices to place the signal farther from the noise floor. However, for devices that are sensitive to high power levels such as amplifiers, use the Low power setting.

For best measurement accuracy, use the Manual power setting at -15 dBm. After calibration, the power level can be decreased for amplifiers, or increased for higher dynamic range.

### CAUTION

Power Level settings in this mode will NOT change Power Level settings in other modes. To help prevent damage to your DUT, use caution when changing modes with your DUT connected to the FieldFox test ports.

---

### How to set Output Power

- Press **Meas Setup 4**.
- Then **Output Power**
  - **High** Sets output power to the maximum achievable power at all displayed frequencies. Output power is NOT FLAT across the displayed FieldFox frequency span. Please see "**Specifications/Data Sheet**" on page 829 for expected power levels.

- **Low** Sets output power to approximately -50 dBm, FLAT across the displayed FieldFox frequency span.
- **Man** (default setting at -15 dBm) Set output power to an arbitrary value, FLAT across the displayed FieldFox frequency span. If flattened power can NOT be achieved, a warning message and beep occurs. To achieve a flattened output power, reduce the power level or stop frequency.
- Then press **Power Level**.
- Then enter a value using the numeric keypad, the **▲▼** arrows, or the rotary knob.
- Press **Enter**.

## System Impedance (Z0)

To accurately view data presented in Smith Chart format, first set the System Impedance.

Learn how to select Smith Chart format in **“Format” on page 98**.

Learn how to make 75Ω measurements at the FieldFox Supplemental Online Help: <http://na.support.keysight.com/fieldfox/help/SupHelp/FieldFox.htm>

### How to set System Impedance

- Press **Meas Setup 4**.
- Then **Settings**.
- Then scroll to System **Z0** and press **Edit**.
- Then type either **50** or **75** and press **Enter**.

## Port Extensions

Port extensions allow you to electrically move the calibration reference plane on either port 1 or port 2 after you have performed a calibration.

### Why use Port Extensions

Use port extensions if you are unable to perform a calibration directly at your device because the location is not accessible. Perform a calibration at a convenient place, then use port extensions to compensate for the time delay (phase shift) to the desired reference plane. On the FieldFox, port extensions does not compensate for the loss of the additional electrical length, nor any mismatch errors beyond the calibration reference plane.

Also use port extensions if you have already performed a calibration, and then decide that you need to add a length of transmission line in the measurement configuration. Use port extensions to “tell” the FieldFox that you have added the length to a specific port.

- With S11 and S22 reflection measurements, the FieldFox doubles the port extension valued that you enter to account for the additional delay in the forward and reverse directions.
- With S21 and S12 transmission measurements, the port 1 and port 2 extensions are added together. This accounts for the total transmission delay going through ports 1 and 2.

Port extensions and Electrical Delay differ in the following ways:

- Electrical delay applies to a specific trace
- Port extensions apply to specific hardware ports

Port Extensions and Electrical Delay can be set independently. When both are set, the delay adds together. Learn more about Electrical Delay in **“Electrical Delay” on page 101**.

### How to apply Port Extensions

- Press **Meas Setup 4**.
- Then **Port Extensions**
- Then **Port Extensions ON**
- Then **Port1 Extension**
- Then enter time value using the numeric keypad, the **▲▼** arrows, or the rotary knob. Press **Enter** or select a seconds (time) multiplier.

You can also set Port Extensions by pressing **Meas Setup 4** then **Calibration** (settings).

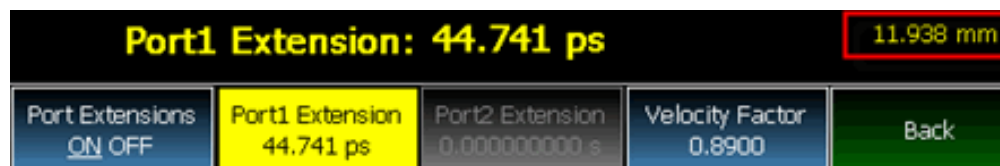

**While setting Port Extension, the physical length of the extension, at the current Velocity Factor setting, is visible to the right (red box in above image).**

### Velocity Factor

The electrical delay or port extension value is entered as delay, or **electrical length**, in units of time.

Entering the velocity factor causes the FieldFox to accurately display the equivalent **physical length** in meters (NOT available in feet) that corresponds to the entered electrical delay.

Velocity factor is the ratio of the velocity of wave propagation in a coaxial cable to the velocity of wave propagation in free space. This velocity depends on the relative permittivity of the cable dielectric ( $\epsilon_r$ ).

$$\text{Velocity factor} = 1/\sqrt{\epsilon_r}$$

VF = 0.66 corresponds to wave propagation through a polyethylene dielectric.

VF = 1.0 (default setting) corresponds to wave propagation through free space (a vacuum).

### How to set Velocity Factor

- Press **Meas Setup 4**.
- Then **Port Extensions**
- Then **Velocity Factor**
- Then enter a value between 0.1 and 1 using the numeric keypad, then press **Enter**.

You can also set Velocity Factor by pressing **Meas Setup 4** then **Calibration (settings)**.

## Big Marker Display States (A and B)

This feature, available ONLY in NA Mode, allows you to view up to three Big or Super Big marker readouts. This is done by using up to two different display states called A and B. Each display state is comprised of the settings listed below. When the Big Readout setting is toggled through A and B, these display states are recalled.

### How to create Big Marker Display States

To have big readouts, markers MUST be created using the following procedure.

If you have already set up your display and do not want to lose it, then save the current state to a state file. Learn how in **“State Files” on page 782**. The following procedure will overwrite your display state.

- Press **Mkr ->/ Tools**
- Then **Big Readout**
  - **A or B** - The A or B display state is recalled. If none have been defined, then the default display state is recalled.
  - **OFF** - The B display state is visible but without the Big Marker Readout.
- With A or B selected, then press **Edit Big Marker (A or B)**
- Then edit the following display state settings:
  - **Num Traces** – Choose the Multi-Trace configuration x1, x2, or x3. Only Overlaid configurations are allowed. Learn more in **“Multi-Trace Configurations” on page 95**.

- **Font Size** – Choose either Big or Super Big. Super Big marker readout #3 will cover some of the measurement grid.
- **Trace Settings** – For each possible trace (1, 2, and 3) select from the following:
  - **Measurement** – S-Parameter or Receiver measurement to display. **S11** is default. Learn more in [“About S-parameters” on page 91](#).
  - **Meas Format** – **Log** is default. Learn more in [“Format” on page 98](#).
  - **Bandwidth (ON)** – Marker readout for marker bandwidth search. OFF is default. Learn how to set BW parameters in [“How to Search with Markers” on page 706](#).
- **Big Readout** – For each marker readout (1, 2, and 3), select from the following:
  - **Marker #** – Enter a number from 1 to 6 to create the marker. 1 is created by default.
  - **Trace #** – The marker# is created on this trace. Tr1 is selected by default. The corresponding Num Traces must first be selected. For example, to create a marker on Trace 3, first select Num Traces = x3.
  - **Format** – Format for the marker readout. Select Default to make the marker readout format the same as the display format. Default is selected by default.
  - **Mkr Tracking** – ON: Select the parameter to track on the standard Marker Search menu. OFF is selected by default. When set to ON, Peak tracking is set by default. Learn about Marker Tracking in [“Marker Functions” on page 713](#).
  - **State** – Choose from Normal, Delta, or OFF. The default marker (1) is created in Normal. Learn more in [“Marker Functions” on page 713](#).
  - **Enabled** – Turns the Big Readout of the corresponding marker ON and OFF. The default marker (1) is set ON by default.

#### Notes:

- To move a marker, press **Marker**, then **Marker**, then scroll to the marker number to be moved. The new marker position can NOT be saved with the A or B display state.
- Settings that are NOT listed above are NOT affected by the recalled display states.
- Changes to the above settings outside the Big Readout menu will be overwritten when Big Readout (A or B) is selected. For example, suppose the display format for the B state is Log. If you change the display format to Lin using the standard menu (Meas 1, Format), the setting will show on the display. But if you then use the Big Readout (A | B | OFF) setting, when B is recalled, the Lin setting will be overwritten with the original Log setting.

## Increase Dynamic Range

Dynamic range is the difference between maximum input power to the FieldFox receiver (without compressing the receiver), and the minimum measurable power (noise floor). Measurement accuracy is increased when the DUT response is at least 10 dB above the noise floor. For a measurement to be valid, input signals must be within these boundaries.

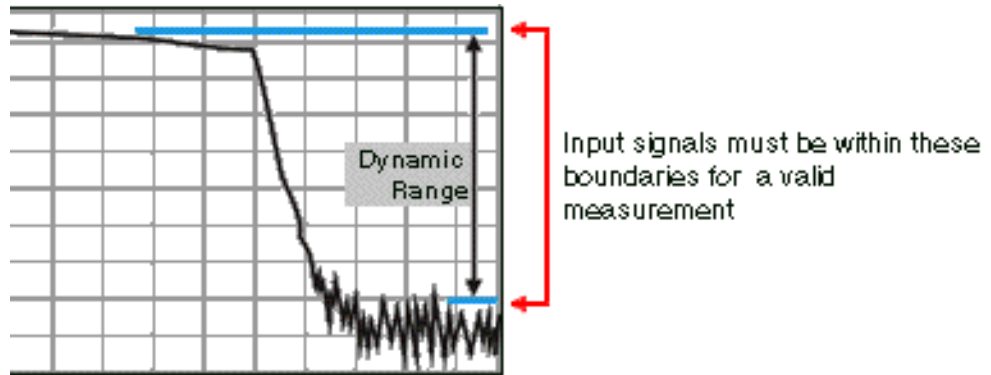

The following settings will increase the dynamic range of your NA mode measurement.

- Increase Power Level: Press **Meas 4** then **Output Power High**
- Lower the IFBW: Press **BW 2** then **IF BW**
- Increase Averaging: Press **BW 2** then **Average**

The following procedure MAY increase the dynamic range of your NA mode measurement. The results you see will depend on the performance of your DUT.

With an S21 trace active:

1. With RF OUT (port-2) open, press **Trace 6** then **Math and Memory** then **Data->Mem**
2. Re-connect the DUT.
3. Press **Data Math** then **Data-Mem**

## 6 Calibration for NA, CAT, and VVM Modes

Calibration removes the systematic errors that are associated with measurements in NA, CAT, and VVM Modes. Key presses are identical in all of these Modes.

### In this Chapter

[“Why and When to Calibrate” on page 126](#)

---

[“Definitions” on page 126](#)

---

[“CalReady” on page 127](#)

---

[“How to Perform a Calibration” on page 127](#)

---

[“Mechanical Cal” on page 129](#)

---

[“ECal” on page 131](#)

---

[“Simple Response Cals ” on page 134](#)

---

[“View Cal” on page 136](#)

---

[“Calibration Type” on page 136](#)

---

[“Enhanced Response Optimization” on page 141](#)

---

[“Interpolation \\*” on page 142](#)

---

[“Cal ON? – Questionable Accuracy” on page 142](#)

---

[“Compatible Mode Calibrations” on page 142](#)

---

[“Save the Calibration” on page 142](#)

---

[“CalReady Properties” on page 142](#)

---

[“Apply Nearest \(NA Mode Only\)” on page 144](#)

---

[“Verify a Calibration” on page 144](#)

---

[“Test the Jumper Cable” on page 145](#)

### See Also

Learn **How to Make 75 ohm Measurements** at the FieldFox Supplemental Online Help:

<http://na.support.keysight.com/fieldfox/help/SupHelp/FieldFox.htm>

## Why and When to Calibrate

There are well-defined and understood systematic errors that are measured and calculated during the calibration process. These errors are caused by leakage signals inside the FieldFox, by the frequency response of the FieldFox receivers, and by reflections inside the FieldFox that interact with the DUT. After calibration, these errors are removed from subsequent measurements.

To maintain highest measurement accuracy, perform a new calibration when any of the following changes occur:

- When any of the following measurement settings change: Frequency Range, Power Level, IF BW, and Resolution. Therefore, make these measurement settings before calibrating. Increased Averaging, lower IF BW, and higher Resolution all cause slower sweeps and slower calibration times. Learn about Interpolation and Questionable Accuracy in **“Interpolation \*” on page 142**.
- When the FieldFox temperature changes more than about 10°F (5°C). Learn more in **“How to monitor the internal FieldFox temperature:” on page 32**.
- When the connection to the DUT changes, requiring a different jumper cable or adapter.

## Definitions

**DUT (Device Under Test)** The cable, antenna, transmission line, amplifier, or anything else that is connected to the FieldFox that is to be measured.

Calibration Standards - OPEN, SHORT, LOAD, and THRU

- **OPEN, SHORT, and LOAD** are ‘reflection’ standards that are used during calibration. When an RF signal ‘hits’ these components, the signals are reflected in a predictable manner. These components can also be used to terminate a DUT port during some measurements.
  - SHORT and OPEN standards both cause 100% of an RF signal to be reflected. The difference between these two standards is what happens to the phase of the reflected signal, which is beyond the

scope of this discussion. Although an OPEN standard is a precision component, simply leaving **nothing** connected at the end of a cable can be a reasonable substitute for an OPEN.

- A LOAD standard absorbs almost ALL of the incident signal and very little signal is reflected back to the source.
- A **THRU** standard is used during some calibration steps to connect PORT 1 to PORT 2 in place of the DUT. A Flush THRU connection can be made when cables that connect with the DUT can mate with each other. Learn more in **“Mechanical Cal” on page 129**. Otherwise, any reasonably short cable can be used as a THRU standard.

**Calibration Reference Plane** is the point (or points) at which the DUT and cal standards are connected during a calibration. This can be at the FieldFox test port connectors, or at the end of jumper cables or adapters.

## CalReady

Every FieldFox contains a factory calibration that was performed at the port 1 and port 2 connectors, with -15 dBm input power, over the entire frequency range of the FieldFox using a number of data points that allows reasonable interpolation over the FieldFox frequency range.

This calibration, known as CalReady, allows you to immediately make measurements of a DUT that is connected directly at the test ports (PORT 1 and/or PORT 2). CalReady corrects measurements when the FieldFox is turned ON and when a measurement is created with no other correction in place.

When measuring a DUT using a jumper cable or adapter - NOT a direct connection to a test port connector - then a Mechanical Cal is recommended. CalReady can also be used to check the integrity of the jumper cable that is attached to the test ports.

**CalRdy** is shown when a measurement is corrected using CalReady.

You can change the properties of the CalReady calibration. Learn more in **“CalReady” on page 127**.

Learn how to see when your factory CalReady calibration was performed in **“System Information” on page 769**.

## How to Perform a Calibration

### NOTE

Press **Esc** at any time to end the calibration process.

When performing a calibration that contains a large number of points (5000 to 10,001 points) be aware that the calibration progress bar may not move for 2 or 3 minutes during the calibration process.

---

In CAT, NA, or VVM Mode, press **Cal 5**.

The following appears:

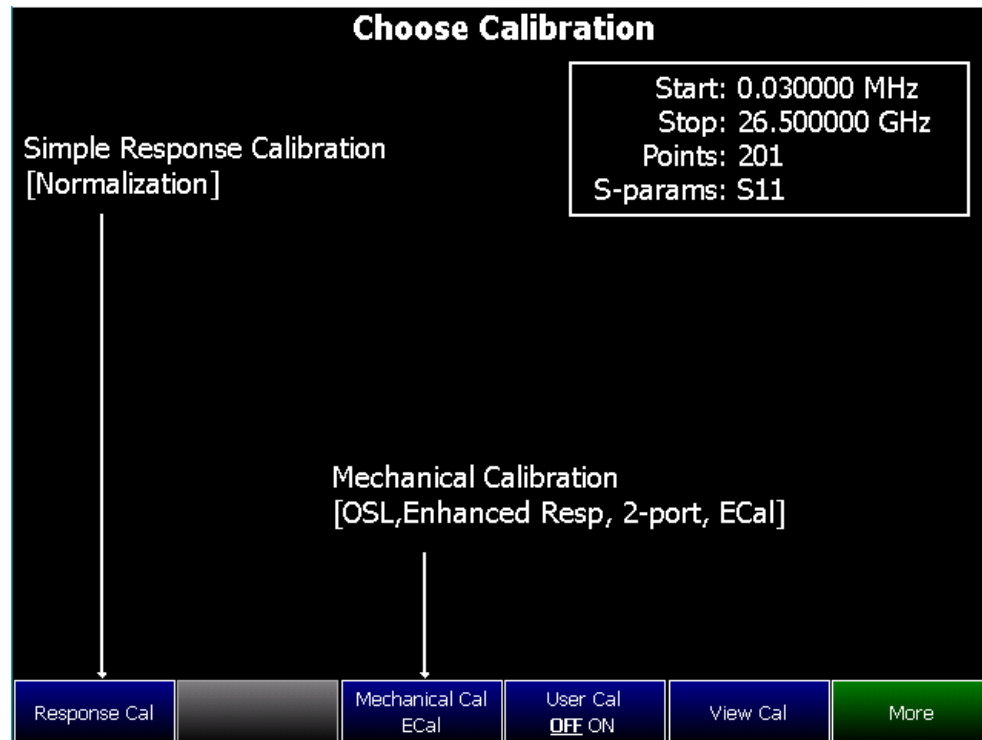

#### Choose Calibration Method screen

- **Response Cal** – Used to quickly calibrate ONE type of measurement using mechanical standards. Measurement accuracy is generally low. Learn more in [“Simple Response Cals” on page 134](#).
- **Mechanical Cal/ECal** – Using mechanical cal standards from a cal kit, perform an accurate calibration at one or both test ports, adapters, or jumper cables. Full 2-port mechanical calibration is the most accurate calibration available with FieldFox. Learn more in [“ECal” on page 131](#).
- **User Cal OFF ON** – Turns ON and OFF the effects of the user calibration that you performed. The OFF state reverts to CalReady.
- **View Cal** – Shows the properties of the current calibration. Learn more in [“View Cal” on page 136](#).
- **More** – Learn about Cal Ready Properties in [“CalReady” on page 127](#).

#### NOTE

Source Unleveled errors - During calibration, the frequency range of the measurement MAY be extended to provide maximum flexibility. During the calibration, the output power may become unleveled at the added high frequencies. You can ignore the “Source Unleveled” error, or to avoid the error, select either High power or -15 dBm before calibrating. Learn more about setting Output Power in [“Output Power” on page 57](#).

## Mechanical Cal

Mechanical Calibration is performed using discrete standards from a Cal Kit. Several Cal Kit definitions are built into the FieldFox. To learn about Cal Kit definitions, refer to the Application Note, “Specifying Calibration Standards and Kits for Keysight Vector Network Analyzers,” available online at <http://literature.cdn.keysight.com/litweb/pdf/5989-4840EN.pdf>

### NOTE

Visit [www.keysight.com/find/fieldfoxsupport](http://www.keysight.com/find/fieldfoxsupport) to see a complete list of supported Cal Kits. Also at this website, download Data-Link software that allows you to edit Cal Kit definitions or add a new Cal Kit.

Mechanical Cals are extremely accurate when performed using the correct Cal Kits with standards that are clean and in good repair, and when using correct connection procedures.

### How to perform a Mechanical Cal

- Disconnect the DUT from the FieldFox.
- If a jumper cable or adapter is required to connect the DUT to the FieldFox, then connect **those** components to the FieldFox connectors. The effects of those components will be measured and removed during the calibration, and only the effects of the DUT will be displayed in the measurement results. **These should be high-quality components!**
- In NA, CAT, or VVM Mode, press **Cal 5**.
- Then **Mechanical Cal**

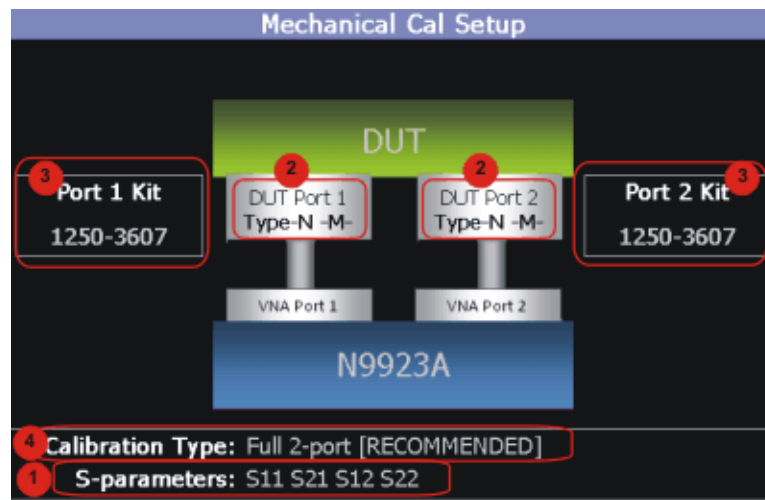

This page summarizes the Mechanical Cal to be performed and allows you to make changes. For best results, review the screen and make changes in the following order:

1. **S-parameters** – Verify that these are all of the S-parameters that you want calibrated. If not, press **Esc** to terminate the calibration process, then return to the Trace menu to display all of the traces to be calibrated. Learn how in **“Multi-Trace Configurations” on page 95**
2. **DUT Connectors** – For each DUT port that is shown, verify the correct type and gender of the DUT connector. If a DUT port is not shown, then that port is not included in the list of S-parameters to be calibrated.
3. **Cal Kit** - Verify the correct Cal Kit for each DUT port to be calibrated. See a list of supported Cal Kits in the FieldFox Data Sheet. Learn more in Appendix B.

If the DUT connector type, gender, or Cal Kit is **NOT** correct for the DUT ports to be calibrated, then:

- Press **Change DUT Connectors** to select the correct connector types that are on your DUT.
  - For each port:
    - Use the **▲▼** arrows or rotary knob to change the DUT connector type.
    - Press **Change Gender** to change the gender of the DUT connector.
    - Then press **Next...** to confirm the selection and continue the process.
  - For each port:
    - Use the **▲▼** arrows or rotary knob to select the Cal Kit that you have, and are going to use, for the specified ports.
    - Press **Next...** to confirm the selection and continue the process.
    - Then press **Finish** to end the selection process.
4. **Calibration Type** - The FieldFox always RECOMMENDS a Cal Type that will quickly and accurately calibrate all of the displayed S-parameters. Change from the RECOMMENDED Cal Type ONLY if you understand the implications. Learn more about Cal Types in **“Calibration Type” on page 136**.

To select a different Cal Type:

- Press **Change Cal Type**.
- Then using the **▲▼** arrows or rotary knob, select a Cal Type,
- Then press **Select and Finish**.

#### Begin Calibration

- Press **Start Calibration**.

#### NOTE

If an error appears (“Failure to compute calibration steps...”), check to ensure that the frequency range of the Cal Kit covers the frequency range of the measurement. You can verify the frequency range of your Cal Kit at: [www.keysight.com/find/fieldfoxsupport](http://www.keysight.com/find/fieldfoxsupport). Click Cal Kits.

---

- Follow the Cal Wizard prompts. Connect the specified standard at the point where the DUT will be connected, then press **Measure**.
- At any time, press **Back** to re-measure a standard if you feel it was not properly connected.
- Press **Finish** to complete the calibration.

**CAL ON U** is shown on the screen for all displayed measurements that are corrected with the Mechanical Cal.

## ECal

#### CAUTION

ECals each have a recommended input power level. Depending on the measurement setup, the FieldFox may default to an input power level that exceeds your ECal’s recommended input power level. Refer to the reference guide for your ECal module to determine the correct input power levels. Exceeding an ECal’s recommended input power level results in a compression and an invalid data condition. Refer to [www.keysight.com/find/ecal](http://www.keysight.com/find/ecal).

---

ECal is a complete solid-state calibration solution. Every ECal module contains electronic standards that are automatically switched into position during a calibration. These electronic standards have been measured at the factory and the data stored within the memory of the ECal module. The FieldFox uses this stored data, along with the measured data, to calculate the error terms for a measurement calibration.

You can perform the following calibrations with ECal:

- 1-Port Reflection calibration
- Full 2-Port calibration

### CAUTION

**Simple ECal ON:** When choosing **Full 2-port** calibration, if you are able to connect your ECal simultaneously to both device ports, you should use **Simple ECal** (i.e, this ensures that you are using the correct Thru calibration model).

**Simple ECal OFF:** Set simple ECal to OFF when you have a test setup where you cannot connect port 1 and port 2 simultaneously to the ECal module (Then during the calibration when prompted: **“Connect port 1 to port 2”**, use a coaxial cable or an appropriate thru adapter to connect port 1 to port 2).

**‘Unknown THRU’:** When prompted: **“Connect port 1 to port 2”**, then you can connect them, using a coaxial cable or an appropriate thru adapter. Do NOT use the internal ECal THRU, because the thru calibration will be incorrect.

**‘Flush THRU’:** When prompted: **“Connect port 1 directly to port 2”**, then you must connect the ports directly together at the calibration reference plane with no adapter or other cabling.

Learn more in **“Calibration Type” on page 136.**

---

All Keysight USB ECal modules are supported. ECal modules are available in a variety of connector types, covering many frequency ranges. For information about available ECal modules, see <http://www.keysight.com/find/ecal>

Select an ECal module that has connectors of the same type and gender as the DUT. If such an ECal module is not available, a module with connectors different from the DUT can be used by selecting a User Characterization. This selection is located on the Mechanical Cal Setup page of the CalWizard. However, a User Characterization can NOT be PERFORMED using the FieldFox. It must be performed using a bench top Keysight VNA, such as the PNA or ENA. Learn more about User Characterization at the PNA Help website: [http://na.support.keysight.com/pna/help/latest/S3\\_Cals/ECal\\_User\\_Characterization.htm](http://na.support.keysight.com/pna/help/latest/S3_Cals/ECal_User_Characterization.htm).

### How to Perform a Calibration Using ECal

- Make measurement settings on the FieldFox (frequency range, number of points, etc.)

### NOTE

The frequency range of the measurement **MUST** be within the frequency range of the ECal module or an error will appear when **“Calculating Steps”** during the calibration.

---

- Connect the ECal module USB cable to the FieldFox USB.
- Allow the module to warm up until it indicates READY. This may take several minutes.
- Connect the ECal module ports to the FieldFox at the calibration reference plane (where the DUT will be connected).
- Press **Cal 5** to start the Calibration.
- Press **Mechanical Cal / ECal**
- Press **Change DUT Connectors**. For each test port to be calibrated, select the **Connector Type** and **Gender** of the DUT / ECal module. The connected ECal module and relevant User Characterizations will appear, with the ECal factory default as the default Cal Kit.
- Optionally press **Advanced** then **ECal Auto Orient**.
  - **ON** (default) The FieldFox automatically senses the direction in which the ECal module ports are connected to the FieldFox ports.
  - **OFF** If power to the ECal module is too low, it cannot detect which FieldFox ports it is connected to. If you are having this problem, select OFF. Then during the calibration, the FieldFox will prompt you to connect the ECal module ports to specific FieldFox ports.
- Optionally press **Advanced** then **Extended Cal** (N995xB/6xB Only).
  - **ON** The FieldFox Extended Cal measures additional points outside the current frequency range in order to enable adjusting the frequency range after the calibration procedure. With these extra points, the error correction may be applied when it otherwise might not. Without extended cal, if you adjust your frequency outside the calibrated range after the calibration has been completed, the error correction is turned off.
  - **OFF** (default) The FieldFox does not measure any frequency points outside the current displayed frequency range. If the frequency is adjusted outside of the set of points calibrated the error correction is turned off and the following message is displayed:  
"Error correction disabled. Stimulus outside calibrated range."

- Press **Start Calibration**. When prompted, verify the ECal module connection, then press Measure. The standards within the ECal module are automatically connected and measured.

**CAUTION**

**'Unknown THRU'**: When prompted: **"Connect port 1 to port 2"**, then connect port and port 2, using a coaxial cable or an appropriate thru adapter. Do NOT use the internal ECal THRU, because the ECal thru calibration model is incorrect for this calibration type.

**'Flush THRU'**: When prompted: **"Connect port 1 directly to port 2"**, then you must connect the ports directly together at the calibration reference plane with no adapter or other cabling.

Learn more in ["Calibration Type" on page 136](#).

---

## Simple Response Cals

Simple Response Cals are used to quickly calibrate the magnitude and phase of a measurement using any Open, Short, or Thru component. These may be calibration standards, but because a Cal Kit is not selected, they are not modeled. Measurement accuracy is generally low. Use a Simple Response Cal to make quick measurements when using a jumper cable to connect the DUT to the FieldFox. Otherwise, CalReady is usually more accurate.

**CAUTION**

**IMPORTANT!**

The Simple Response calibration assumes an ideal response for the standard. DUT measurements after a Simple Response calibration will have a measurement bias equivalent to the deviation of the response of the device used as the Simple Response standard from the ideal response. Note, that an Open Response is simply a normalization, a Short response is a normalization with 180 degree phase offset. When selecting a standard from the 85058B calibration kit for a Short Response we suggest using short # 1 because it has the smallest delay of the four shorts and would thus be most similar to an ideal short.

For better accuracy, perform a mechanical calibration by referring to ["Mechanical Cal" on page 129](#).

---

**NOTE**

You can perform a Simple Response Cal for either: S11, or S22, or S21 AND S12.

---

When prompted, choose a standard based on the displayed measurements to be calibrated. For example, to calibrate S11, connect either an OPEN or SHORT to the port 1 reference plane.

When Simple Response Cals are performed, the source match and reflection tracking terms from CalReady are updated by the measured Short or Open that is used during the calibration.

1-port response cals are also available from the Mechanical Cal menu. Learn more in [“Calibration Type” on page 136](#).

**Normalize** uses a THRU standard or cable between port 1 and port 2 to cal an S21 and S12 Transmission measurement (NA Mode) and a 2-port Insertion Loss measurement (CAT Mode). In VVM Mode, this is performed using Zero.

When a Normalization is performed, the forward and reverse transmission tracking terms from CalReady are updated to account for the THRU that is used during the normalization process.

### How to perform a Simple Response Cal

- Select the measurements to be calibrated. See the relevant Mode (NA, CAT, or VVM) for measurement selections.
- Press **Cal 5** then **Response Cal**
- For 1-port measurements:
  - Select either **Open Response** or **Short Response** for the port to be calibrated. The availability of this calibration on Port 2 may require an option.
  - Connect an OPEN or SHORT standard to the specified port and press **Measure**
- For 2-port measurements:
  - Select **Normalization**
  - Connect a short, high-quality, phase stable cable between the FieldFox port 1 and port 2 connectors, then press **Measure**

#### NOTE

With a Normalization Cal, all subsequent insertion loss measurements are made relative to the insertion loss of the cable used as the THRU standard. For example, if you use a cable with 1 dB of loss, then after Normalization, the display will show 0 dB of loss with this cable in place. Therefore, for highest accuracy, when measuring the DUT also attach the cable that was used in the normalization cal.

- 
- Press **Finish**.
  - Connect the DUT.

**CAL ON U** is shown on the screen when a User Cal (Ex: Response Cal) is correcting ONLY the appropriate measurement. For example, when an Open Response Cal on Port 2 is performed, **CAL ON U** is shown for an S22 measurement only.

## View Cal

From the **Choose Calibration** screen (see [“How to Perform a Calibration” on page 127](#)), press View Cal to see the following screen:

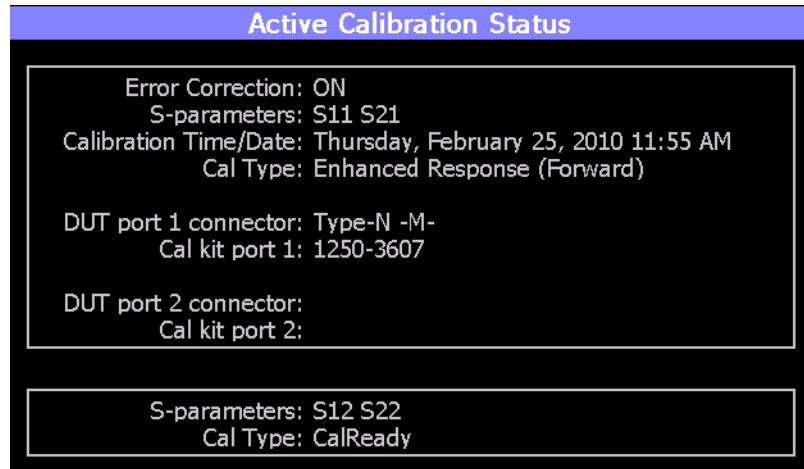

The top box shows the properties of the current calibration that you performed and the displayed S-parameters that it is correcting.

The bottom box shows the S-parameters that are displayed but NOT corrected by the current performed calibration, but rather the CalReady calibration. Learn more about CalReady in [“CalReady” on page 127](#).

## Calibration Type

The FieldFox simplifies the calibration process by recommending the most accurate and efficient calibration type based on the displayed S-parameters.

However, there may be times when you may want a little more accuracy or a little faster sweep time. The following information can help you learn about the various calibration choices.

**Definitions:**

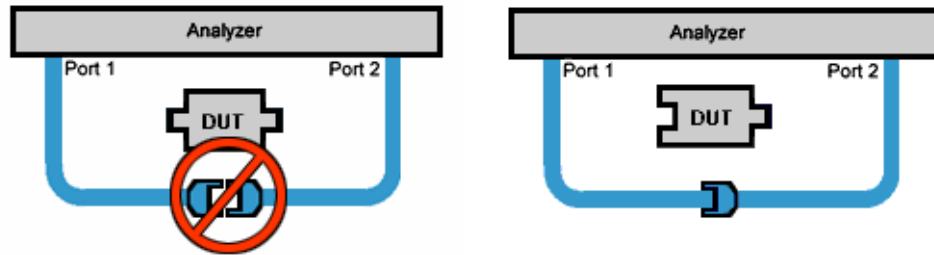

**Non-insertable DUT** – A device whose connectors could NOT mate together. They either do not have the same type of connector or they have the same gender. This also means that the test port cables could NOT mate together as in the above diagram.

**Insertable DUT** – A device whose connectors could mate together. They have the same type of connector and opposite or no gender. This also means that the test port cables could mate together, as in the above diagram.

**Defined THRU** – A THRU standard for which there is a Cal Kit definition such as in the 8551xA Cal Kits.

**Flush THRU** (also known as Zero length THRU) – When the test port cables mate together when measuring an Insertable DUT. No actual THRU standard is required because the test port cables are directly connected. Flush THRU is also a Defined THRU with a definition of zero loss and zero length.

**Unknown THRU** – Any THRU connection between the test ports. For more information see the FieldFox Supplemental Online Help:

<http://na.support.keysight.com/fieldfox/help/SupHelp/FieldFox.htm>

**Sweep Directions** – Both FULL 2-Port Cals listed below result in correction that requires background measurements sweeps in both directions, regardless of the displayed measurements. The displayed traces are updated at a slower rate than Enhanced Response and 1-port calibrations, which require sweeps in one direction only.

**1-Port (OSL)**

DUT: No restrictions

S-parameters Corrected: S11 or S22

Standards: OPEN, SHORT, LOAD

Sweeps in ONE direction.

**FULL 2-Port (May require an option)**

Most comprehensive calibration. Corrects all S-parameters

DUT: Non-Insertable or Insertable

Standards: OPEN, SHORT, LOAD on **BOTH** ports. Any THRU between ports.

Based on the SOLR/Unknown THRU calibration. For more information on the Unknown THRU process, see the FieldFox Supplemental Online Help: <http://na.support.keysight.com/fieldfox/help/SupHelp/FieldFox.htm>

Sweeps in BOTH directions.

### **FULL 2-Port (QSOLT) – Mechanical Cal ONLY (May require an option)**

Quicker to perform QSOLT than Full 2-port. Corrects all S-parameters.

DUT: Insertable only

Standards: OPEN, SHORT, LOAD on port 1. Flush THRU between ports.

Recommended cal type for Insertable DUTs. A Cal Kit is NOT required for port 2.

Sweeps in BOTH directions.

### **Enhanced Response Cal - Forward OR Reverse (May require an option)**

Faster measurements than Full 2-Port.

DUT: Non-Insertable or Insertable. S-parameters PARTIALLY Corrected: S21 and S11 (Forward) **OR** S12 and S22 (Reverse)

Standards: OPEN, SHORT, LOAD on **ONE** port. Defined or Flush THRU between ports.

Sweeps in ONE direction.

## **NOTE**

Also select an Enhanced Response Optimization. Learn more in “[Enhanced Response Optimization](#)” on page 141.

### **TRL – Mechanical Cal ONLY**

A complete 2-Port calibration with potentially better accuracy than Full 2-port. Corrects all S-parameters.

DUT: Non-Insertable or Insertable

Standards: Thru, Reflect, Line or variations of these. A TRL Cal Kit **MUST** be selected to see this Cal Type

Sweeps in BOTH directions.

Learn more about TRL Calibration in the Supplemental Online Help: <http://na.support.keysight.com/fieldfox/help/SupHelp/FieldFox.htm>

### **1-port Response Cals (Open or Short)**

Calibrate the magnitude and phase of a measurement using ‘modeled’ mechanical standards. Measurement accuracy is better than Simple Response Cals (available on the main Cal page - see “[Calibration Type](#)” on page 136) but NOT as good as full 1-port cal. Corrects either S11 or S22. Can be used with Isolation (see following section). Learn more in “[Simple Response Cals](#)” on page 134

DUT: Non-Insertable or Insertable

S-parameters Corrected: S11 or S22

Standards: OPEN or SHORT on ONE port

Sweeps in BOTH directions.

## Isolation Step

The optional isolation step of a calibration corrects for crosstalk which is the internal signal leakage between the test ports. The Isolation step measures Load standards that are connected to one or both FieldFox test ports.

Perform an isolation calibration when you are testing a device with high insertion loss, such as the stop band of a filter or a switch in the open position.

The isolation step can add noise to the error model when the measurement is very close to the noise floor of the analyzer. To improve measurement accuracy, set a narrow IF Bandwidth during the calibration.

The Isolation step is NOT allowed with ECal.

### How to perform the Isolation step

- Press **Cal 5** then **Mechanical Cal / ECal**
- Then **Advanced**
- Then **Omit Isolation**
  - **OFF** Perform the Isolation step
  - **ON** (default) Omits the Isolation step
- Then **<Back**
- Configure and perform the calibration as usual. At the first step of the Cal you will be prompted to connect a Load standard to one or both test ports.

#### NOTE

If the first calibration step does NOT prompt you to connect Load standards, then the Cal Kit probably does not contain an Isolation standard. You can use DataLink software to edit the Cal Kit and add an isolation standard using a Load standard. See Data Link Help for more information:

<http://na.support.keysight.com/help/DataLinkHelp/DataLink.htm>

- 
- This setting survives an Instrument Preset.

## Waveguide Calibrations

In general, calibrating with Waveguide is very similar to calibrating with coax. However, most coax mechanical Cal Kits have standards that can be used over a very wide frequency range. Waveguide Cal Kits are used over a narrow frequency range. Therefore, it is VERY IMPORTANT to set the frequency range

of the measurement WITHIN the frequency range of the waveguide Cal Kit. Otherwise, an error message will appear during the 'Calculating Steps' portion of the calibration.

### Waveguide Cal Kits

Keysight sells two waveguide Cal Kit series: the premium 11644A series and the economy N9911X series. Both are available online at [www.Keysight.com](http://www.Keysight.com)

### Effective Velocity Factor

Velocity factor is the speed at which an electromagnetic signal passes through the transmission medium relative to the speed of light. This value is important when distance is being calculated in DTF measurements (CAT mode) and Time Domain (NA mode).

When the media is waveguide, the velocity factor changes with frequency. FieldFox calculates this 'effective' velocity factor automatically. However, the settings are different for CAT mode and NA mode.

### CAT Mode - How to make Waveguide settings

These settings are necessary ONLY when making DTF measurements.

- Press **Measure 1** then **Distance to Fault (dB)** to select a **DTF** measurement.
- Press **Meas Setup 4**
- Then **Settings** (Learn how to use the Quick Settings table in “How to view and change Quick Settings” on page 52.)
- Set **Media = Waveguide**. Frequency Mode = **BandPass** is automatically selected for you.
- Scroll down to **Waveguide Definitions**. Select the **Waveguide Standard** being used. If your waveguide standard is NOT listed:
  - Select **User Waveguide**. Then press **Done**.
  - Then **DTF Cable Specifications**, then **Edit/Save/Recall Cables**, then **Edit Cable**.
  - Scroll to set **Waveguide Definition**. The default setting is **VF Corr = Auto**.
  - Set the Min, Max, and Cutoff Frequencies.
- Press **Done**, then press **Back**.
- **Cable Correction = Auto** is the default setting. The Effective Velocity Factor is calculated automatically based on the frequencies of the waveguide standard. To override this setting, set Cable Corr = **Man**.

### NA Mode - How to make Waveguide settings

These settings are necessary ONLY when your measurement requires electrical delay or port extensions, or if using Time Domain Transform.

- Press **Meas Setup 4**
  - Then **Transform**
  - Then **Transform Settings**
  - Under **Transform Stimulus Settings**, set the **Start** and **Stop** frequencies to those of the Waveguide.
  - Set **Stimulus = Bandpass Impulse**
  - Press **Done**
  - Press **Meas Setup 4** or **Back**
  - Then **Calibration Settings**
  - Set **Media = Waveguide**
  - Set **Cutoff Frequency**. This is the absolute minimum frequency of the waveguide. This value must be less than the Start Frequency of the Waveguide.
- Enter the calculated **Effective VF** value into the Velocity Factor setting.

## Enhanced Response Optimization

When Enhanced Response Cal Type is selected, either for one calibration or for CalReady, this setting optimizes the calibration based on the type of DUT being measured. See also: CalReady Properties in **“CalReady” on page 127**.

This setting does NOT survive Preset.

- Press **Cal 5** then **More**
- Then **Enh.Response**
- Then choose from:
  - **NonReciprocal** (default) An amplifier is a Non-Reciprocal device because it has gain in the forward direction, and very high loss (isolation) in the reverse direction. This choice provides the best correction for non-reciprocal devices, and reasonable correction for reciprocal devices.
  - **Reciprocal** A reciprocal DUT is a device in which the insertion loss through the device is equal in both the forward (S21) and reverse (S12) directions. A cable is a reciprocal device. This choice provides the best correction for reciprocal devices. However, S11 measurements on non-reciprocal devices will appear to have more return loss than the non-reciprocal choice.

## Interpolation \*

Highest measurement accuracy is achieved when the frequency range or resolution settings remain the same during the measurement as when the FieldFox was calibrated. If these settings change after performing a calibration, the FieldFox will interpolate the calibration so that VERY accurate measurements continue to be made.

Interpolated Calibrations are only slightly less accurate than a calibration performed at the measurement settings. Learn more about the relative accuracy of FieldFox calibrations in **“Cal ON? – Questionable Accuracy” on page 142.**

When a calibration that you performed is being interpolated, an asterisk is added to the Cal annotation. For example: Cal ON U\* is shown on the screen when the current Response or Mechanical cal is being interpolated. An \* is never added to a CalRdy.

## Cal ON? – Questionable Accuracy

When the Output Power, Interference Rejection, or IF BW (NA Mode ONLY) setting is changed AFTER performing a calibration, a question mark is added to the Cal annotation.

The resulting measurement accuracy depends on how much the setting has changed. For highest accuracy, recalibrate using the new settings.

## Compatible Mode Calibrations

The FieldFox can have only ONE calibration present for all modes. Because NA, CAT, and VVM modes are very similar, a calibration that is performed in one mode can also be applied in the other modes with the same type of measurements (1-port or 2-port).

To apply a Cal that was performed in a different mode, press **Cal 5** then select **User Cal ON**.

## Save the Calibration

After performing any type of calibration, you can save the FieldFox settings along with the calibration into a STATE (\*.sta) file. These settings and calibration can then be recalled as necessary. To learn how, see **“Saving and Recalling Files” on page 778.**

## CalReady Properties

There are several factory calibrations (CalReady) on every FieldFox. These can be selected based on the type of DUT that you measure most often, and the compromise that you prefer to make between measurement speed versus

measurement accuracy. Remember, CalReady was performed at the test ports. Therefore, a CalReady calibration is most accurate when the DUT is directly connected to the test ports. Learn more in [“CalReady” on page 127](#).

This setting does NOT survive Preset or Power ON/OFF.

- Press **Cal 5** then **More**
- Then press **CalReady** to toggle between the following selections:
  - **2-Port Cal** (default) Corrects all four S-parameters. Requires a forward and reverse sweep, which causes slower trace measurements. Learn why in [“Calibration Type” on page 136](#).
  - **Enh. Response** Corrects forward (S21 and S11) and reverse (S12 and S22) measurements separately. Therefore, when measurements in only one direction are required, this choice provides faster trace measurements than a full 2-port cal. Also choose an Enhanced Response Optimization. Learn more in [“Enhanced Response Optimization” on page 141](#).

To find the best choice for your DUT:

- Press **Preset** then **Preset**.
- Select the appropriate S-Parameter and other settings (frequency range, resolution, and so forth).
- Press **Trace 6** then **Math and Memory** then **Data->Mem**.
- Press **Data & Memory**.
- Press **Cal 5** then **More**
- Select a CalReady Cal to compare with the current setting.
- Press **Esc** to exit the cal menu.
- View the differences in the two traces.

## Apply Nearest (NA Mode Only)

When **Apply Nearest** is pressed, interpolation is turned off and the nearest calibration point is applied when the start stop frequencies are changed for the current sweep.

### CAUTION

#### IMPORTANT!

- Apply Nearest needs to re-selected after each pair of start and stop frequency points is entered, because the Apply Nearest feature is disabled when a new start stop frequency pair is selected.
- Apply Nearest calculates the number of points based on the start and stop frequency points entered.
- Apply Nearest will display the following error when there is no valid calibration found:

“Error: 225, The required user calibration is not present.”

---

To use **Apply Nearest**:

- Press **Cal 5** > **More** > **Apply Nearest**

## Verifying Calibration and Jumper Cable Integrity

After calibrating, it is important to verify that the calibration is good. When using a jumper cable, also verify that the cable is of high quality.

### Verify a Calibration

- Connect a LOAD standard at the calibration reference plane (where calibration standards were connected). This may be at the end of the jumper cable or at FieldFox **PORT 1** connector.
- In CAT Mode, select **Return Loss**.
- In NA Mode, select **S11** with Log Mag format.
- For frequencies **lower than 9 GHz**, observe the trace on the FieldFox screen:
  - Lower than 35 dB indicates a GOOD calibration.
  - Higher than 30 dB indicates that you should recalibrate.

### Verifying Phase Accuracy

- Connect a LOAD standard at the calibration reference plane (where calibration standards were connected).
- In NA Mode, select a S11 Reflection with Polar or Smith Chart format.

- Because all LOAD standards have delay, you should see a small amount of phase rotation as a function of frequency. In general, the measurement result should agree with the characteristics of the calibration standard.

### Test the Jumper Cable

With the LOAD standard still connected, move the jumper cable while observing the trace.

- If the measurement trace is relatively stable, the jumper cable is of good quality.
- If you observe significant movement in the peaks of the measurement trace when moving the cable ( $>5$  dB), the jumper cable may need to be replaced.

## Calibration Method Summary

- **Mechanical Full 2-port Cal** is ALWAYS the most accurate Cal method. The quality of a Mechanical Cal is completely dependent on the quality of the OPEN, SHORT, LOAD standards and the quality of the standard connections. Use the correct high quality standards to ensure the most accurate calibration.
  - Even with the optional Load, phase accuracy begins to degrade when the return loss is greater than about 20dB.
- **CalReady** is accurate ONLY when the DUT is directly connected at the test ports and most accurate at room temperature.
- **For highest accuracy**, a new Mechanical Cal should be performed:
  - When the temperature changes more than about 10°F (5°C)
  - When the connection to the DUT requires a different jumper cable or adapters.
  - When any of the following measurement settings change: Frequency Range, Power Level, IF BW, and Resolution.

## 7 SA (Spectrum Analyzer) Mode (Option 233–Mixed Analyzers)

### NOTE

To better reflect the enhancements implemented during the alignment process, for firmware versions >A.10.15 “IF Flatness Alignment” is now referred to as “Channel Equalization” or “Channel Equalization Alignment” ([ChanEQ Alignment](#)).

SA Mode measures signals at the **SA RF IN** connector.

SA Mode measurements require NO calibration.

For a comprehensive SA mode tutorial, see Spectrum Analysis Basics (Application Note 150) at

<https://www.keysight.com/us/en/assets/7018-06714/application-notes/5952-0292.pdf>

For information on using the FieldFox Remote Viewer which enables you to view the FieldFox from your iOS device, refer to

<https://www.keysight.com/us/en/assets/7018-04070/application-notes/5991-2938.pdf>

Figure 9-1 SA Display with Markers

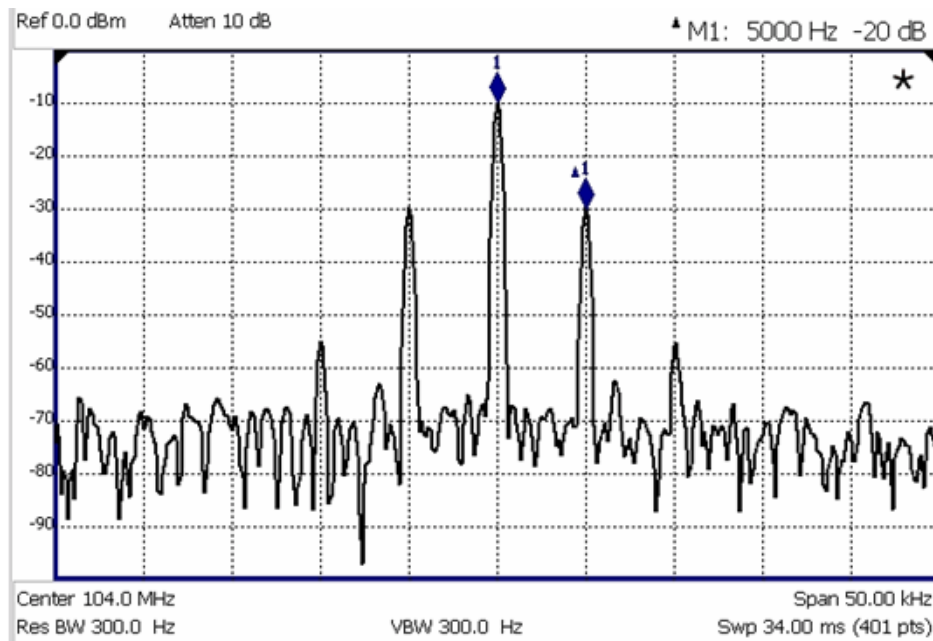

**The graphic above shows an SA display with markers.  
Carrier with 5 kHz frequency modulation and deviation of 1 kHz.**

### **In this Chapter**

[“Frequency Range” on page 151](#)

---

[“Radio Standard” on page 153](#)

---

[“Channel Selection” on page 155](#)

---

[“Reverse Swap” on page 156](#)

---

[“Scale and Units” on page 157](#)

---

[“External Gain” on page 158](#)

---

[“Attenuation Control” on page 159](#)

---

[“Preamplifier Control \(Opt 235\)” on page 160](#)

---

[“Check for Compressed Measurements” on page 160](#)

---

[“Field Strength Measurements” on page 161](#)

---

[“Using the Antenna/Cable Editor” on page 163](#)

---

[“Source Tracking Offset and Offset Reversal” on page 166](#)

---

[“Tune & Listen \(AM/FM\)” on page 166](#)

---

[“Analog Demod” on page 170](#)

---

[“Independent Source/Tracking Generator ” on page 181](#)

---

[“Resolution Bandwidth \(Res BW\)” on page 182](#)

---

[“Video Bandwidth \(Video BW\)” on page 183](#)

---

[“AF RBW \(Audio-Frequency Resolution BW\)” on page 184](#)

---

[“Sweep Type” on page 184](#)

---

[“IF Output” on page 185](#)

---

[“Sweep Acquisition” on page 188](#)

---

[“Very Long Sweep Times” on page 190](#)

---

[“Zero Span Measurements” on page 190](#)

---

[“Triggering” on page 192](#)

---

[“FFT Gating \(Opt 238\)” on page 196](#)

---

[“Single / Continuous / Restart” on page 198](#)

---

[“Points ” on page 198](#)

[“Trace Display States \(SA Mode\)” on page 198](#)

---

[“Average Type” on page 199](#)

---

[“Average Count” on page 200](#)

---

[“Alignments” on page 201](#)

---

[“RF Burst Amplitude Alignment” on page 206](#)

---

[“Detection Method” on page 208](#)

---

[“Display Line” on page 210](#)

---

[“Noise Marker” on page 211](#)

---

[“Band/Interval Power Marker” on page 211](#)

---

[“Frequency Counter at Marker” on page 212](#)

---

[“Audio Beep at Marker Power” on page 213](#)

---

[“Meas UNCAL Error” on page 214](#)

---

[“Old Data Indicator \(\\*\)” on page 214](#)

---

[“Radio Standards and Channel Measurements” on page 215](#)

---

[“Measurement Preset” on page 215](#)

---

[“Averaging” on page 215](#)

---

[“Traces” on page 216](#)

---

[“Channel Power \(CHP\)” on page 216](#)

---

[“How to Set Up EMF Settings \(Requires EMF \(Option 358\), GPS \(Option 307\), and SA Mode \(Option 233–Mixed Analyzers\)\)” on page 226](#)

---

[“Spectrum Emission Mask \(SEM\) – \(SA Mode Only\)” on page 238](#)

---

[“IQ Analysis \(Requires Option 351 IQ Analyzer and Option 353 IQ Streaming, SA Mode Only\)” on page 245](#)

---

[“Effective Isotropic Radiated Power \(EIRP\) – \(SA Mode Only\)” on page 248](#)

## See Also

### Interference Analyzer:

[“Spectrogram Display \(SA Option\)” on page 514](#)

---

[“Waterfall Display” on page 517](#)

---

[“Record/Playback \(SA Option\)” on page 519](#)

**Optional Settings:**

---

[“All about Markers” on page 700](#)

---

[“All about Limit Lines” on page 715](#)

---

[“Saving and Recalling Files” on page 778](#)

## SA Mode Settings

Select SA Mode before making any setting in this chapter.

Because there is no calibration, these settings can be made in any order.

### How to select SA Mode

- Press **Mode**
- Then **SA**.

### Frequency Range

The X-axis frequency range determines the frequencies that are measured for each sweep. The default Start frequency is 0 Hz. However, the Start frequency can be set as low as –100 MHz. The internal LO of the FieldFox can be seen at 0 Hz, which will mask signals that may be present.

#### NOTE

Although the start frequency can be set as low as –100 MHz, amplitude accuracy is specified above 9 kHz. Below 9 kHz, frequency accuracy is maintained, but amplitude accuracy is degraded.

The FieldFox can be used with an OML frequency extender. Refer to [“Utilities” on page 732](#), the [B Series FieldFox Configuration Guide 5992-3701EN](#), and to [“Contacting Keysight” on page 5](#).

Available ONLY with Opt. 209 and while in Step sweep, SA mode allows reverse sweeps. This means the Start frequency can be higher than the Stop frequency. In addition, the **Reverse Swap** feature can be used to quickly reverse the Start and Stop frequencies. Learn how in [“Reverse Swap” on page 156](#).

The frequency range of the measurement can be changed using the following methods:

- Set Center and Span frequencies
- Set Start and Stop frequencies
- Toggle between Zero and Last selected span
- Set Full Span of the FieldFox
- Using Channel selection. Learn how in [“Channel Selection” on page 155](#).
- Using Marker > Center (frequency). Learn how in [“SA Marker Functions” on page 714](#).

### How to set Frequency Range

- Press **Freq/Dist**.
- Then choose from the following:

- **Center** and **Freq Span** frequencies. This is the most common method of entering frequency range. Enter the frequency of interest. The Center frequency is at the exact center of the X-axis. The Frequency Span places half of the frequency range on either side of center. When the Center and Frequency Span values are entered, then the X-axis annotation on the screen shows the Center and Span frequencies.

**NOTE**

Integration BW (IBW) is coupled to the Frequency Span setting. Frequency Span is 50% wider than the IBW (e.g., if the IBW value is 1 MHz, then the Frequency Span value is 1.5 MHz).

---

- **Start** and **Stop** frequencies. Start is the beginning of the X-axis and Stop is the end of the X-axis. When the Start and Stop frequencies are entered, then the X-axis annotation on the screen shows the Start and Stop frequencies.

**NOTE**

Integration BW (IBW) is coupled to the Frequency Span setting. Frequency Span is 50% wider than the IBW (e.g., if the IBW value is 1 MHz, then the Frequency Span value is 1.5 MHz).

---

- Follow each of these by entering a value using the numeric keypad, the **▲▼** arrows, or the rotary knob.
- When using the **▲▼** arrows, press **Enter**. The increment setting of the arrows is based on the current span. This can be changed in SA Mode. See **How to change frequency step size** below.
- After using the keypad, select a multiplier key. Learn more in **“Multiplier Abbreviations” on page 46**.

### Two more ways to change the frequency range

- Press **Freq/Dist**
- Then choose from the following:
  - **Zero/Last Span** Each key press toggles the frequency span between 0 Hz and the last specified frequency span. Learn more about Zero Span in **“Zero Span Measurements” on page 190**.
  - **More**
  - Then **Full Span** Selects the entire frequency span of the FieldFox. The Center frequency is set automatically.

**NOTE**

When in full span, ADC dither raises the noise floor at the edges of the 120 MHz.

---

## How to change frequency step size

When using the  arrows to change any of the frequency settings, the size of the frequency step can be changed.

- Press **Freq/Dist**
- Then **More**
- Then **CF Step Auto Manual**
  - **Auto** Each press of the  arrows increments or decrements the value by 1/10th (one division) of the current frequency span. **Note:** To change this setting from **Manual** to **Auto**, press **CF Step** twice.
  - **Manual** Type a step size value using the numeric keypad, then select a multiplier key. Learn more in [“Multiplier Abbreviations” on page 46](#).

## How to change from Linear to Log Axis View

- Press **Freq/Dist** > **More**
- Then choose from the following:
  - **Log Freq AxisX** enables/disables the log frequency X-axis. Disabling the log frequency X-axis, enables the linear frequency X-axis (Default = OFF).
  - Then **Full Span** Selects the entire frequency span of the FieldFox. The Center frequency is set automatically.

### NOTE

When in full span, ADC dither raises the noise floor at the edges of the 120 MHz.

## Radio Standard

A Radio Standard is a collection of settings that are applied to the FieldFox for specific RF protocols. When a Radio Standard is applied, the FieldFox frequency and channel settings change to that of the standard.

By default, the FieldFox locates the center frequency of the standard in the middle of the screen and sets the frequency span to cover all of the Uplink and Downlink frequencies. The selected Radio Standard name appears in the center of the screen below the X-axis.

After a Radio Standard has been selected, the frequency range can be changed by selecting channel numbers rather than frequency. Learn how in [“How to set Frequency Range” on page 151](#).

When a Channel Measurement is selected such as ACPR, other relevant settings will be changed such as Integration BW. Learn more about Radio Standards and Channel Measurements in [“Radio Standards and Channel Measurements” on page 215](#).

## How to select a Radio Standard

- Press **Measure 1** OR **Freq/Dist** then **More**
- Then **Radio Standard**
- Then **Radio Standard**
- Then select a standard using the **▲▼** arrows or rotary knob and press **Enter**.

## Custom Radio Standards

Your own custom Radio Standards can be imported into the FieldFox. Custom standards are created in \*.csv (spreadsheet) format.

A template and instructions for creating your custom Radio Standard is at: <http://na.support.keysight.com/fieldfox/help/SupHelp/Reference/CustomRadioStandard.htm>

Once imported, the \*.csv file is stored in the FieldFox \User Data\ folder. The custom Radio Standards are read and presented at the top of the list of internal Radio Standards.

## How to Import and Delete a Custom Radio Standard

First, press **Save/Recall** and select the **Device** from which the Radio Standard will be read. Most likely this will be **USB** or **SD Card**.

- Press **Measure 1** OR **Freq/Dist** then **More**
- Then **Radio Standard**
- Then **Radio Standard**
- Then **Import Radio Standards**
- Then select the \*.csv file using the **▲▼** arrows or rotary knob and press **Enter**.
- Custom Radio Standards can be removed from the FieldFox by selecting **Measure 1** then **Radio Standard** then **Delete Radio Standard**.
- Then select the \*.csv file to delete using the **▲▼** arrows or rotary knob and press **Enter**.

### NOTE

To overwrite a custom standard that is already uploaded to the FieldFox, you must first delete the \*.csv file from the FieldFox, then re-upload the file that contains the standard. A predefined internal standard (such as GSM 450) can NOT be deleted from the FieldFox.

---

## Channel Selection

After a Radio Standard has been selected, the frequency range can be changed by selecting channel numbers rather than frequency. Once enabled, the channel number is appended to the X-axis frequency range.

### How to Enable Channel selection

- Press **Freq/Dist**
- Then **More**
- Then **Unit Freq Chan**

With Unit = **Chan**, **Channel Direction** becomes available and **CF Step** alters to **Channel Step**.

### How to change the Channel Number of the Measurement

With Unit = **Chan** the FieldFox will NOT allow you to specify channels outside of the selected Radio Standard.

- Press **Freq/Dist**
- Then choose from the following:
  - **Center Channel** Places the center frequency of the specified channel in the middle of the X-axis.
  - **Start Channel** Places the lowest frequency of the specified channel at the beginning of the X-axis.
  - **Stop Channel** Places the highest frequency of the specified channel at the end of the X-axis.
  - **Freq Span** Changes the span of frequencies while the center frequency remains unchanged.

#### NOTE

Integration BW (IBW) is coupled to the Frequency Span setting. Frequency Span is 50% wider than the IBW (e.g., if the IBW value is 1 MHz, then the Frequency Span value is 1.5 MHz).

- 
- Follow each of the above settings by entering a value using the numeric keypad or the rotary knob.
  - Use the **▲▼** arrows to increment the channel number by an amount specified by the Channel Step value (see below).
  - Then press **Enter** or **Enter**.

### Select either Uplink or Downlink Frequencies

Press **Freq/Dist** then **More**. Press **Chan Direction** to toggle between **Uplink** and **Downlink**. If either of these selections is not available, then the selected Radio Standard does not contain those frequencies. In that case, **Chan Direction** is grayed out.

### Channel number X-axis annotation

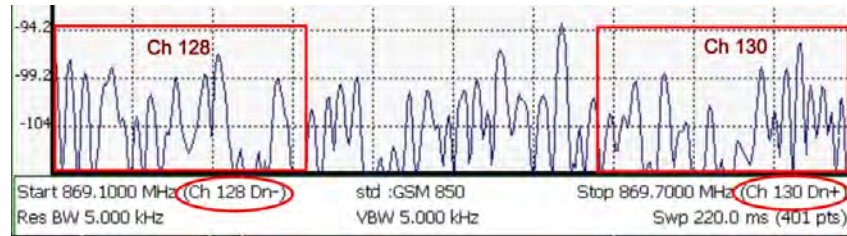

- **Dn** indicates **Downlink** channels.
- **Up** (not shown) indicates **Uplink** channels
- **(-)** indicates that the lowest frequency in the channel (128) is at the left edge of the screen.
- **(+)** indicates that the highest frequency in the channel (130) is at the right edge of the screen.
- When Center Channel or Freq Span is specified, the X-axis shows the Center Freq (Channel) and Frequency Span.
- When Start or Stop Channel is specified, the X-axis shows the Start Freq (Channel) and Stop Freq (Channel).

### Change Channel Step Size (Optional)

This setting allows you to use the **▲▼** arrows to increment the channel number by the specified value. The **Channel Step** softkey appears only when it is valid. Learn how to make it valid in the section, “See How to change the Channel Number of the measurement”?

- Press **Freq/Dist** then **More**.
- Press **Channel Step**
- Enter a step value using the numeric keypad, the **▲▼** arrows, or the rotary knob. Then press **Enter**.

### Reverse Swap

Available ONLY with Opt. 209 and while in Step sweep mode. Each press of the softkey causes the Start and Stop frequencies to swap. The Start becomes the Stop and vice versa. Learn more about Step versus FFT sweeps in **“FFT Gating (Opt 238)” on page 196**.

- Press **Freq/Dist** then **More**.
- Then **Reverse Swap**

## Scale and Units

Adjust the Y-axis scale to see the relevant portions of the data trace.

The Y-axis is divided into 10 graticules. A acquisition is shown on the screen as a solid horizontal bar that can be placed at any graticule.

When RF Attenuation set to **Auto**, the RF Attenuation is coupled to acquisition.

### How to set Scale

Press **Scale / Amptd**. Then choose from the following:

- **Autoscale** Automatically adjusts the Y-axis to comfortably fit the Minimum and Maximum amplitude of the trace on the screen.
- **Scale** Manually adjust the scale per division to view specific areas of the current trace. Enter a value using the numeric keypad, the **▲▼** arrows, or the rotary knob. Then press **Enter**.
- **Ref Level** Manually set the value of the reference line. Enter a negative value by pressing **Run/Hold (+/-)** either before or after typing a value. This can also change the RF Attenuation setting. See **“Attenuation Control” on page 159**.
- **Preamp** Refer to **“Preamplifier Control (Opt 235)” on page 160**.
- **RF Atten** Refer to **“Attenuation Control” on page 159**.
- **More** opens another set of scale softkeys.

### Manually set Scale Type, acquisition, and Reference Position.

- **Scale Type [current setting]**
  - **Log** Logarithmic scale (default setting). The Y-axis reference line represents the specified absolute acquisition in the current Unit selection. Y-axis graticules show dB below or above the reference line.
  - **Lin** Linear scale. The Y-axis reference line represents the specified absolute acquisition in the current Unit selection. Y-axis graticules show percent of acquisition (%) below or above the reference line.
- **Unit** Refer to **“How to Set Y-axis Units” on page 158**.
- **Corrections** Refer to **“How to select and edit corrections for Field Strength measurements” on page 161**.

- **External Gain** Refer to “External Gain” on page 158.
- **Ref Pos** Manually set the position of the reference line. Values must be between 0 (TOP line) and 10 (BOTTOM line). Default position is zero (top).

### How to Set Y-axis Units

The Unit setting appears for the reference line, marker readouts, and trigger level. All Unit choices are available in both Log and Linear Scale Types.

The UNIT setting survives Mode Preset, but NOT Preset.

- Press **Scale / Amptd**, then **More**, then **Unit**
- Then choose from the following:
  - **dBm** (default setting), **dBmV** (dB milli Volts), **dBuV** (dB microVolts), **W** (watts), **V** (volts), **A** (amps), **dBmA** (dB milliAmps), **dBuA** (dB microAmps).

Antenna correction units are available ONLY by loading or editing an Antenna file that contains the desired units setting. Learn more In.

### External Gain

When using an external amplifier or attenuator, the SA mode trace amplitude values can be offset to compensate for the effect of the external device. This effectively moves the reference plane of the SA measurement port out to just beyond the external device. For example, when using an external preamp with gain of +10 dB, enter this value for External Gain, and the data trace across the displayed frequency span will be adjusted down by 10 dB.

When RF Atten is set to Auto, you may see a change in the RF Attenuation value. This is an attempt to measure the signal at top of screen (the acquisition) without overloading the SA first mixer.

### How to Set External Gain

- Press **Scale/Amptd**.
- Then **More**
- Then **External Gain**
- Enter a value using the numeric keypad, the **▲▼** arrows, or the rotary knob (positive for gain; negative for loss). Values less than 5 dB must be typed using the numeric keypad. Then press **Enter**

**ExtGain xx dB** is shown at the top of the screen.

## Attenuation Control

Both the RF Attenuation and Preamp functions control the power level into the SA.

When too much power is present at the RF Input port, **ADC Over Range** appears on the FieldFox screen. This does not necessarily mean that damage has occurred, but that the measurement is probably compressed.

When high power levels are present at the RF Input port, internal attenuation can be switched in to keep the FieldFox receiver from compressing. At extremely high power levels, use external attenuation to protect the internal circuitry from being damaged.

### CAUTION

The FieldFox can be damaged with too much power. Refer to the FieldFox Data Sheet for your model on

<https://www.keysight.com/us/en/assets/7018-06516/data-sheets/5992-3702.pdf>.

Maximum Input Voltages and Power:

RF Output Connector: 50V DC, +23 dBm RF

Ext Trig/Ref Connector: 5.5 V DC

RF Input:

+27 dBm RF,  $\pm 50$  VDC Max. (N991xA/B, N9925B, N9926A, N9928A, N993xA/B)

+23 dBm RF,  $\pm 50$  VDC Max. (N9923A, N9923AN)

+25 dBm RF,  $\pm 40$  VDC Max. (N995xA/B, N996xA/B)

DC Input: 19VDC, 4ADC, 60 Watts maximum when charging battery

The displayed power level is automatically adjusted for RF Attenuation. As the attenuation value changes, the displayed power level should NOT change.

### How to set Attenuation

- Press **Scale/Amptd**.
- Then **RF Atten Auto Man**.
- **Auto** RF Attenuation is set by adjusting the acquisition. As the acquisition is lowered, for example from  $-10$  dBm to  $-40$  dBm, the FieldFox assumes that you are looking at low-level signals. The RF Attenuation value is automatically lowered in 5 dB steps to allow low-level signals to be viewed. The RF Attenuation value is never automatically lowered below 5 dB.
- **Man** RF Attenuation is set manually. The default Attenuation setting is 10 dB. Enter a value between 0 to 40 dB in 5 dB steps using the numeric keypad, the **▲▼** arrows, or the rotary knob. Then press **Enter**.  
#Atten xx dB is shown at the top of the screen. (#) means manual setting.

## Preamplifier Control (Opt 235)

When **very low-level** signals are analyzed, an internal preamplifier can be used to boost the signal level by approximately 22 dB. The gain of the preamp is NOT adjustable. The displayed signal level is automatically adjusted for the increase in system gain.

### How to control the Preamp

By default, the preamp is OFF.

- Press **Scale/Amptd**.
- Then **Preamp ON OFF**. The underlined setting is the current setting. When ON, **PA** is shown to the left of the graticules on the display.

## Check for Compressed Measurements

Compression occurs when too much power into an amplifier causes it to no longer amplify in a linear manner. When too much power goes into the FieldFox RF Input connector, the amplifiers in the SA receiver compress and signal power will not be displayed accurately. This can occur even if **ADC Over Range** is not displayed because devices other than the ADC, such as the mixer, might be compressed. Increase the RF Attenuation value to prevent the SA receiver from being compressed.

### How to Check for a Compressed Measurement

- Using a marker at the signal peak, make note of the signal power level.
- Increase the RF Attenuation level by 5 dB.
  - If the signal level does NOT change, then NO compression exists. This indicates that the signal is in the linear region of the FieldFox receiver.
  - If the signal level DOES increase, then the receiver was compressed. Set the RF Attenuation value at the setting when further increases no longer result in an increase in the displayed power level.

## Field Strength Measurements

To measure the strength of any signal transmitted through the air, an antenna must be connected to the FieldFox. The Field Strength feature allows you to enter the frequency response of the receiving antenna (the Antenna Factor) and associated cabling, and then have amplitude corrections automatically compensate the displayed trace for that response.

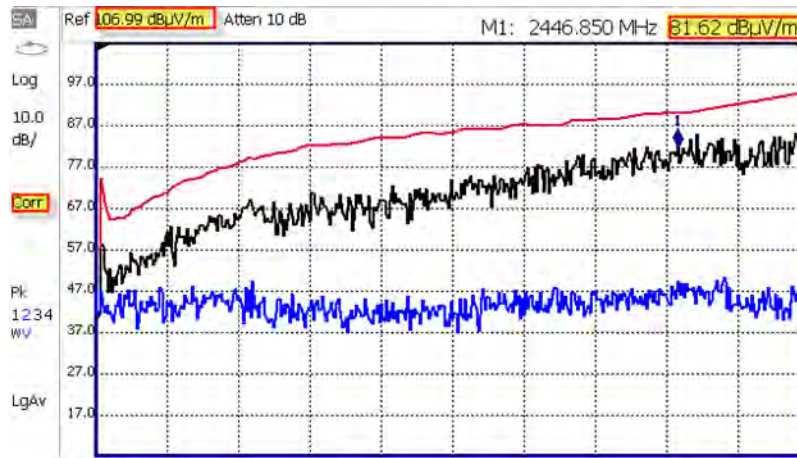

### Field Strength Measurements

**Trace 1** - Corrected trace with antenna factor. (Antenna = ON, Apply Corr = ON)

**Trace 2** - Uncorrected trace (Apply Corr = OFF). The Trace 2 trace state is “View.” For information, refer to [“Trace Display States \(SA Mode\)”](#) on page 198

**Pink Trace** - Current correction factor. See below.

- Learn how to set Y-Axis **Units** on [“How to Set Y-axis Units”](#) on page 158.
- Use a Band Power marker to measure total power over a range of frequencies. Learn how in [“Band/Interval Power Marker”](#) on page 211

### How to select and edit corrections for Field Strength measurements

The Antenna and Cable correction data survives a Mode Preset and Preset.

All Correction ON/OFF states survive a Mode Preset, but NOT a Preset.

- Press **Scale/Amptd** > **More** > **Corrections**
- Then choose from the following:
  - **Apply Corrections Auto Disabled** Use Auto and Disabled correction for all settings. (Default = Auto).
  - **Antenna Off** – Opens a softkey menu to enable/disable a antenna and edit, save, create a new antenna factors table, recall, and set a storage device location.

- **Cable Off** – Opens a softkey menu to enable/disable a cable and edit, save, create a new cable description table, recall, and set a storage device location.
- **More** – Opens a softkey menu to View Corrections and set the Amplitude Correction type for your antenna.  
Learn more, see **“Selecting and Viewing Corrections” on page 162.**
- **More** – Edit/Recall an Antenna file to be used to transmit.
- **RcvrSide Antenna Off / On** Edit/Recall an Antenna file to be used to receive.
- **SrcSide Cable Off / On** Edit/Recall a Cable file to be used on the Source side.
- **RcvrSide Cable Off / On** Edit/Recall a Cable file to be used on the Receiver side.

### Selecting and Viewing Corrections

- Press **Scale/Amptd** > **More** > **Corrections** > **More**
- **View Corrections ON OFF** Turn ON and OFF Pink Trace - Antenna/Cable corrections. This is a composite of all cable/antenna corrections that are currently applied. Available as a useful visual aid, the zero “dB” level (no net correction) is mapped to appear at the -50 dBm on-screen level.
- **Amp Corr Select [Triaxial XYZ]** – then choose one of the following:
  - **Default** Receiver side only antenna measurements.
  - **Src/Rcvr Split** to work with non-triaxial receiver and source side antenna measurements.
  - **Triaxial XYZ** (default, when Channel Power is on and when a compatible triaxial antenna’s factors have been imported) for measuring channel measurements and EMF.

### How to Use the Antenna Softkeys

The following menu appears when any of the above Antenna Off or Cable softkeys are pressed:

- **Antenna/Cable ON OFF** – Turn correction ON or OFF for this Antenna/Cable.
- **Edit Antenna/Cable** – Edit an Antenna/Cable Correction table. See Using the Antenna/Cable Editor (below) for more information.
- **New** – Create a new Antenna/Cable. See Using the Antenna/Cable Editor (below) for more information.

- **Save Antenna/Cable** – Save the modified Antenna/Cable to a file on the specified Storage Device.
- **Recall Antenna/Cable** – Read an existing Antenna/Cable file from the specified Storage Device.
- **Storage Device** – Choose from: Internal, USB, SD. Learn more about these selections in **“Set File Type and Select Device” on page 783.**

When finished, press **Back** to return to the previous menu.

## Using the Antenna/Cable Editor

The Antenna Editor and the Cable Editor menus are very similar. Both tables include header information, and a Frequency/Value table.

Figure 9-2 FieldFox Antenna Editor – E-Field and H-Field Units Displayed

Setting	Value
Description	Correction Fac
Freq Interpolation	!LIN
Antenna Factor Unit	dB /m
Frequency	Antenna Factor
26.00000000 MHz	20.00 dB /m
30.00000000 MHz	17.50 dB /m
40.00000000 MHz	13.50 dB /m
50.00000000 MHz	10.50 dB /m
60.00000000 MHz	8.20 dB /m
70.00000000 MHz	7.20 dB /m
80.00000000 MHz	7.10 dB /m
90.00000000 MHz	7.30 dB /m
100.0000000 MHz	7.50 dB /m
110.0000000 MHz	7.60 dB /m
120.0000000 MHz	7.50 dB /m
130.0000000 MHz	7.60 dB /m

Setting	Value
Description	Correction Fact
Freq Interpolation	LIN
Antenna Factor Unit	dB S/m
Frequency	Antenna Factor
26.00000000 MHz	20.000 dB S/m
30.00000000 MHz	17.500 dB S/m
40.00000000 MHz	13.500 dB S/m
50.00000000 MHz	10.500 dB S/m
60.00000000 MHz	8.200 dB S/m
70.00000000 MHz	7.200 dB S/m
80.00000000 MHz	7.100 dB S/m
90.00000000 MHz	7.300 dB S/m
100.0000000 MHz	7.500 dB S/m
110.0000000 MHz	7.600 dB S/m
120.0000000 MHz	7.500 dB S/m
130.0000000 MHz	7.600 dB S/m

## How to use the Antenna/Cable Editor

- Press **Scale/Amptd** > **More** > **Corrections** then choose:
  - **Antenna Off** to open the antenna editing softkeys
  - **Cable Off** to open the cable editing softkeys

Once you have selected Antenna or Cable to edit:

- Press **New** then **Yes** to clear all data from the existing Antenna or Cable table and reset header information to default settings.

- Then **Edit Antenna** or **Edit Cable** to open the Antenna / Cable Editor.  
(Antenna must be enabled to view a change in the antenna units.)
- Then use the **▲▼** arrows to select a field.
  - To edit header information, press **Edit** then modify the selected field using the FieldFox labeler.
    - **Description**: Enter a description for the antenna or cable correction table. This is NOT the filename used to save the file.
    - **Antenna Factor Unit** (Rcvr-side Antennas only): Units in which the measurement will be displayed. Select **NONE** (default setting) to select from standard SA Units on the Scale menu. Learn how in **“Scale and Units” on page 157**.
    - Choose from: **dB  $\mu$ V/m** - (dB micro Volts per meter), **dB  $\mu$ A/m** - (dB micro Amps per meter), **dBG** (gauss), **dBpT** (tesla).
    - **Freq Interpolation**: Set to LINear and can NOT be edited.
  - To edit **Frequency/Value** pairs, enter numbers using the numeric keypad, and a frequency suffix when necessary.
    - For both **Cable Loss** and **Antenna Factor** values, Positive numbers indicate loss (we need ADD something positive to compensate for it), and Negative is indicative of some existing gain.
    - **Antenna Factor** describes the dB value needed to accurately display a far-field signal in terms that are in the units listed below. When the antenna has low gain, or low efficiency, the dB value to be added is larger.
    - **Antenna Factor Unit** sets the type of antenna factor unit used in your measurement (i.e., dB /m or DB S/m).
  - When one Freq/Value pair is entered, that correction value is applied to the entire displayed frequency span.
  - When two or more Freq/Value pairs are entered, the data points between the lowest and highest frequencies are corrected. Linear interpolation is applied between frequencies when necessary.
- Optionally choose from the following:
  - **Previous / Next Page** Quickly scrolls through pages of Freq/Value data.
  - **Add Row** Add a blank Freq/Value pair to the table,
  - **Delete/Clear** then:
    - **Delete Row** Remove the selected Freq/Value pair from the table.

- **Clear All** then **Yes** Remove all Freq/Value pairs from the table and resets header information to default settings.

### When the table edits are complete

- Press **Done** to close the Antenna/Cable Editor.
- Press **Save Antenna** or **Save Cable** to save your changes to the specified Storage Device. Enter a filename using the FieldFox labeler (learn more in [“How to use the FieldFox labeler ” on page 780](#)). Learn more about Antenna and Cable files below.
- Press **Recall Antenna** or **Recall Cable** to load an Antenna or Cable file from the specified Storage Device.
- **Storage Device** Changes the device used to save or recall files. Choose from Internal (default setting), USB (must be connected) or SD card. This is a different setting from the Save/Recall Storage Device setting.

### About Antenna and Cable files

- Cable files are saved and recalled from the **Cables** folder.
- Antenna files are saved and recalled from the **Antenna** folder.
- To **DELETE** Cable or Antenna files, use the Manage Files feature. Learn more in [“Manage Files” on page 786](#).
- If the folder does not already exist on a USB or SD card, it is created automatically before storing the file.
- All SA mode Antenna and Cable files are saved and recalled as \*.csv files, which allows them to also be read by spreadsheet programs.
- The FieldFox can also read \*.ANT (Antenna) files that were created from older Keysight Spectrum Analyzers.
- SA Mode cable or antenna (\*.csv or \*.ANT) files can NOT be edited in Data Link software.

### How to create a Cable file from an S21 (NA mode) or an Insertion Loss (CAT mode) measurement

1. Measure the S21 or Insertion Loss of a cable. In NA mode, select either LogMag, Linear, or VSWR formats.
2. Use **Manage Folders** to change the active folder to **CABLES**. Learn how in [“Manage Folders” on page 788](#).
3. While in NA mode, save the measurement as a \*.csv file. Learn how in [“How to Save a File” on page 778](#).

**4. In SA mode, select Corrections, then recall the \*.csv file for correction.**

## Source Tracking Offset and Offset Reversal

This feature requires:

- N991xB and N995xB FieldFox Combination Analyzers to have Options 209, 210, and 233
- N993xB and N996xB Spectrum Analyzers to have Options 209 and 220

Source offset tracking is used to offset the Source frequency from the Receiver frequency by a fixed offset at every tune frequency. This feature is used when the DUT contains a frequency translation device or mixer.

### How to set Tracking Offset and Offset Reversal

- On the Receiver unit, press **Measure 1**
- Then **Source**
- Then **Advanced**
- Then choose one or both of the following:
  - **Tracking Offset** Enter an offset value.
  - **OffsetReversal** Determines whether Receiver Freq is added to or subtracted from the Offset Freq.
    - **OFF**  $\text{SourceFreq} = \text{Offset} + \text{RecFreq}$ . Use to measure Upconverters.
    - **ON**  $\text{SourceFreq} = \text{Offset} - \text{RecFreq}$ . Use to measure Downconverters. The source sweeps in Reverse direction. Note: The Offset Freq. MUST be larger than the Receiver Stop Freq.

## Tune & Listen (AM/FM)

The Tune & Listen feature can be used to identify an interfering AM or FM signal.

The demodulated AM or FM signal can be heard through the internal speaker or through headphones using the 3.5 mm jack located on the FieldFox side panel.

The Tune & Listen tuner is separate from the SA display. This allows you to listen to one frequency while displaying a different range of frequencies. The Tune & Listen measurement alternates between normal SA sweeps for the display and performing audio demodulation at the Tune Frequency. See the Listen Time setting for more information.

Figure 9-3 Tune & Listen ON

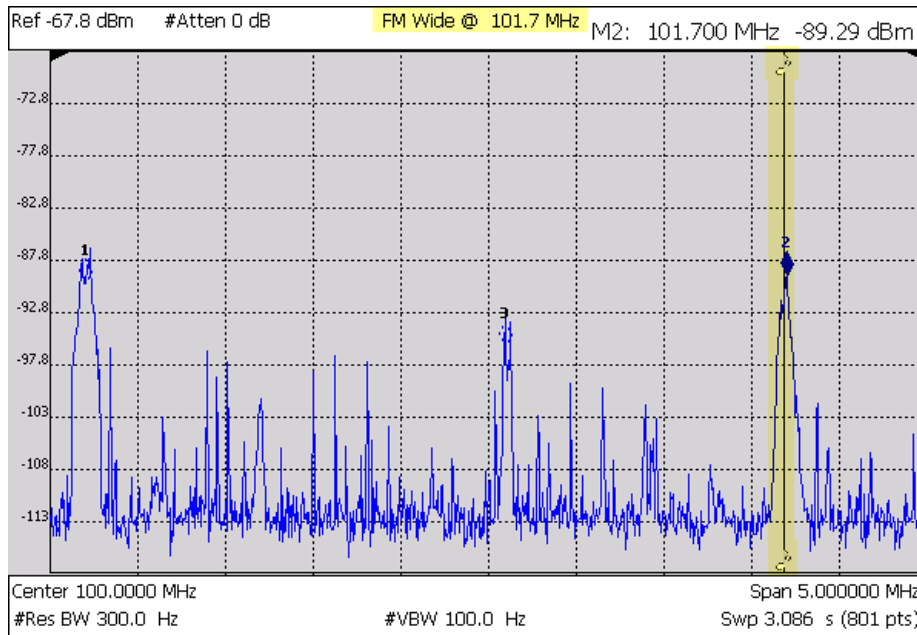

In the graphic above, Tune & Listen ON with Tune Frequency is indicated by a vertical bar (highlighted).

This section contains the following:

---

“How to select Tune & Listen” on page 167

– “TnL AM SSB Gain” on page 168

---

“Tune Frequency” on page 168

---

“Listen Time” on page 169

---

“To select Listen Time:” on page 169

---

“Volume Control” on page 169

---

“Audio Demod ON and OFF” on page 170

---

“Setting the Marker Counter Precision Softkey” on page 170

---

“Setting the Mkr->TuneFreq Softkey” on page 170

### How to select Tune & Listen

- Press **Measure 1**
- Then **Analog Demod Tune & Listen** > **Tune & Listen**

- Then choose a demodulation type. Select a setting based on the type of interfering signal you suspect is being broadcast.
  - Press **Meas Setup 4** > **TnL Demod Type** then
  - **AM** – Sets AM (Double-sideband with carrier) as the modulation type.
  - **FM Narrow** – Sets Frequency Modulation; Narrow bandwidth. Choose when interfering transmission consist of voice or data.
  - **FM Wide** – Sets Frequency Modulation; Narrow bandwidth. Choose when interfering transmission consist of voice or data.
  - **AM USB** – Sets the modulation type to AM upper sideband. Annotation: AM USB @ *Center Frequency* displayed at the top of display. See also, “**TnL AM SSB Gain**”.
  - **AM LSB** – Sets the modulation type to AM lower sideband. Annotation: AM LSB @ *Center Frequency* displayed at the top of display. See also, “**TnL AM SSB Gain**”.

See also, “**How to select Analog Demod (Metrics)**” on page 172.

### TnL AM SSB Gain

When you select **AM USB** or **AM LSB** softkeys, the **TnL AM SSB Gain** softkey becomes active.

- Press **Meas Setup 4** > **More** then
- **TnL AM SSB Gain** – sets the gain in the IF path for TnL SSB measurements (the optimal IF path gain is automatically determined/set for regular AM and all the other demod types, but it cannot be automatically determined for AM SSB so it has to set it manually).

The goal is to set the gain as high as possible (to take advantage of the range of the IF and audio paths) without distorting the audio signal. It is recommended that you keep increasing the gain until you hear distortion in the audio and then back off until you no longer hear any distortion. (Default = 0, Minimum = -50 dB, Maximum = +50 dB)

#### NOTE

The system volume setting should still be used to determine the final desired volume/level of the audio output. Learn more, see also **Chapter 30**, “**System Settings.**” and “**Audio (Volume) Control**” on page 728.

### Tune Frequency

The Tune & Listen tuner is separate from the SA display. This allows you to listen to one frequency while displaying a different range of frequencies.

Set the Tune Frequency using one of three methods:

1. Selecting **Preset** > **Mode Preset**, sets Tune Frequency to 3.25 GHz (e.g., for a N9914B FieldFox).
2. Specify Tune Frequency:
  - Press **Meas Setup 4** > **Tune Freq**
  - Enter a value using the numeric keypad, **▲▼** arrows, or the rotary knob. Then select a multiplier key. Learn about multiplier abbreviations [“Multiplier Abbreviations” on page 46](#).
3. Using Mkr->Tune Freq:
  - Create a normal marker at the frequency of interest. Learn how in [“How to create Markers” on page 700](#).
  - Press **Mkr->/Tools**
  - Then **Mkr->TuneFreq** to change the Tune Frequency to that of the marker.

#### NOTE

To improve sound quality, try increasing power by reducing the Attenuation setting and, if available, turn ON the Preamplifier. Learn how in [“Attenuation Control” on page 159](#)

## Listen Time

While Tune & Listen is actively demodulating a signal, the SA does not sweep and update the display. Listen Time sets the amount of time that the FieldFox demodulates, then stops to perform a single sweep and update the display, then again demodulates.

### To select Listen Time:

- Press **Meas Setup 4** > **Listen Time**
- Enter a value using the numeric keypad, **▲▼** arrows, or the rotary knob. Then select a multiplier key. Learn about multiplier abbreviations.

## Volume Control

To increase or decrease the Volume of the demodulated signal:

- Press **Meas Setup 4** > **Volume**
- Enter a value in percent between 0 and 100 (loudest) using the numeric keypad, **▲▼** arrows, or the rotary knob.
- Volume can also be changed and easily muted from the **System** menu. Learn more in [“How to set the FieldFox Volume Control” on page 729](#).

## Audio Demod ON and OFF

To quickly stop the audio demodulation and perform only the normal SA sweeps, select the following:

- Press **Meas Setup 4** > **Audio Demod ON OFF** > **OFF**

## Setting the Marker Counter Precision Softkey

When **AM Tune & Listen**, **FM (narrow) Tune & Listen**, or **FM (wide) Tune & Listen** are selected, you can choose from the following:

- Press **Marker** > **Peak**
- Press **Mkr->/Tools** > **More** > **Mkr Properties** > **Counter Precision** – Sets the AM or FM Metric demodulated signal's marker precision (.1 Hz, 1 Hz, 10 Hz; default = 0.1 Hz).

The Counter Precision softkey is **not** available when AM Metric or FM Metric are enabled. See also, **“Setting the Mkr->TuneFreq Softkey” on page 170.**

## Setting the Mkr->TuneFreq Softkey

When **AM Tune & Listen**, **FM (narrow) Tune & Listen**, or **FM (wide) Tune & Listen** are selected, you can choose from the following:

- Press **Marker** > **Normal**
- Press **Mkr->/Tools** > **Mkr->TuneFreq** – The Tune & Listen Frequency becomes the frequency of the active marker (When **AM Metrics** or **FM Metrics** are selected this softkey is inactive).

See also, **“How to use Marker Functions” on page 713.**

## Analog Demod

The Tune & Listen feature can be used to identify an interfering AM or FM signal. Also, AM/FM Metrics displays the demodulated signal and the audio frequency spectrum.

The demodulated AM or FM signal can be heard through the internal speaker or through headphones using the 3.5 mm jack located on the FieldFox side panel.

The Analog Demod spectrum is displayed alongside the SA displayed trace. This enables you to listen and display a carrier frequency and its harmonics. The Analog Demod measurement displays a normal SA sweeps for the display while performing audio demodulation at the carrier Frequency. See the [“How to select Analog Demod \(Metrics\)” on page 172](#) setting for more information.

Figure 9-4 AM DSB (Metrics) – Demodulation Spectrum

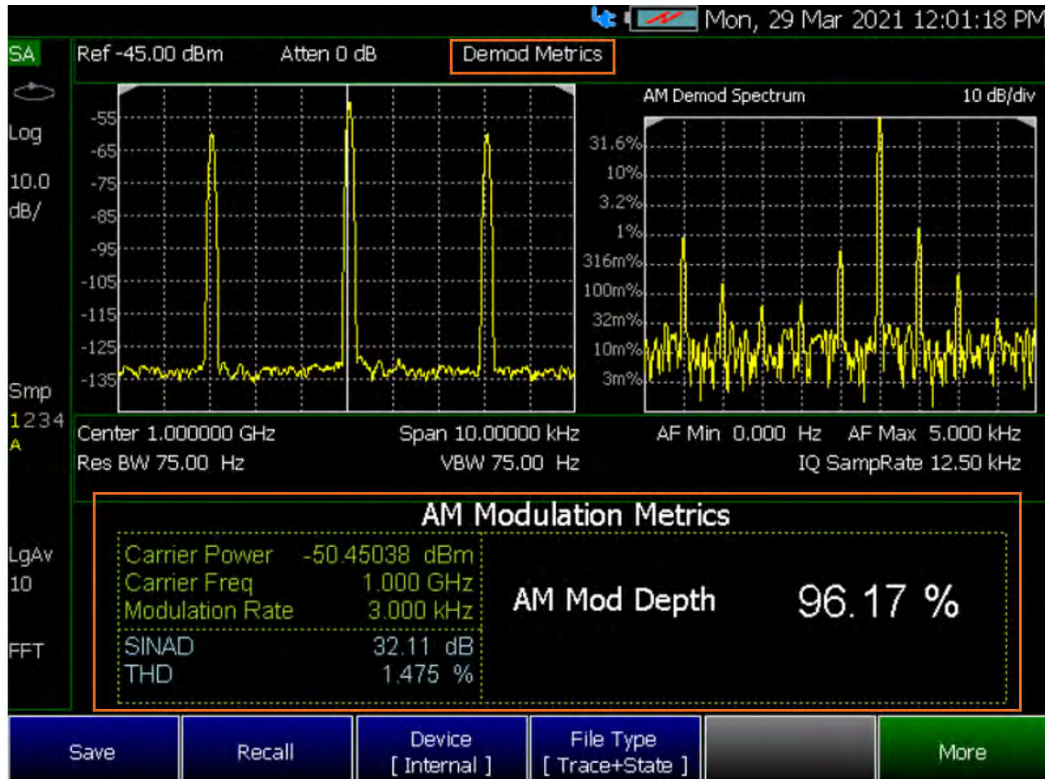

In the graphic above, Analog Demod ON and Demod Metrics is indicated above in the x2 displays of carrier spectrum content. For this example, AM Modulation Metrics are displayed in the lower half of the display. See also, [Figure 9-5 on page 179](#), [Figure 9-6 on page 179](#), [Figure 9-7 on page 180](#), and [Figure 9-8 on page 180](#).

This section contains the following:

---

[“How to select Analog Demod \(Metrics\)” on page 172](#)

---

[“How to make Analog Demodulation \(Metrics\) Settings” on page 173](#)

---

[“Setting the Alternate Frequency \(AF\) Freq/Dist Softkeys” on page 174](#)

---

[“Setting the Alternate Frequency \(AF\) RBW Softkey” on page 175](#)

[“Setting the Audio Capture Playback Softkeys” on page 175](#)

---

[“How to Set the Demod Filters” on page 177](#)

---

[“Setting the Marker Counter Gate Softkey” on page 178](#)

## How to select Analog Demod (Metrics)

Analog demodulation can demodulate AM DSB, AM SSB, FM, FM Stereo / RDS, PM signals. Under analog demodulation metrics the following information is reported for each signal type: Carrier power, modulation rate, SINAD, THD, plus deviation, depth, or RMS depending on the signal. Metrics also displays the demodulated signal and the audio frequency spectrum.

Learn more, [Chapter 26, “AM/FM Metrics \(SA Only and Option 355\).”](#)

- Press **Measure 1** > **Analog Demod Tune & Listen** > **Analog Demodulation**
- **Demod Type** – Then choose a demodulation metric type. Select a setting based on the type of interfering signal you suspect is being broadcast.

### NOTE

**IMPORTANT!** The FieldFox contains only one speaker that supports mono audio output (i.e., if you play a stereo WAVE file, the Left and Right channels are output in mono audio). If you want to output a stereo WAVE file in stereo (to hear the left and right channels separately on the FieldFox) you have to use the headphone jack and stereo headphones (i.e., most earbuds, headphones, etcetera support stereo). Learn more, see also [Chapter 30, “System Settings.”](#) and [“Audio \(Volume\) Control” on page 728.](#)

- **AM** – AM (double sideband). Displayed values for AM Modulation (metrics) – (i.e., includes AM Mod Depth, AM Demod Waveform, SINAD, THD, Carrier Power, Carrier Freq, Modulation rate).
- **AM SSB** – AM single sideband. Displayed values for AM SSB (metrics) – (i.e., includes SSB RMS Level, SSD Demod Waveform, SINAD, THD, RF Power, Modulation rate).
- **FM** – Displayed values for FM Modulation (metrics) (i.e., includes Freq Deviation, FM Demod Waveform (Time)/Spectrum (Frequency), Carrier Power, Carrier Freq, Modulation Rate, SINAD, THD).

- **FM Stereo / RDS** – Displayed values for FM Stereo / RDS (Radio Design System); (Metrics) – (i.e., includes Freq Deviation, FM Demod Waveform (Time)/Spectrum (Frequency), Carrier Power, Carrier Freq, Modulation Rate, SINAD, THD, Dist/ Total VRMS).

**NOTE**

When FM Stereo /RDS is selected as the demodulation type, a Warning message is displayed for a few seconds at the start of the sweep; the sweep is 30 to 50 seconds long.

The message reads:

"Warning: Slow Measurement. RDS Measurement in Progress."

- **PM** – Displayed values for PM Modulation Metrics (i.e., includes PM Deviation, PM Demod Waveform, SINAD, THD, Carrier Power, Carrier Freq, Modulation Rate).
- **Tune & Listen OFF** – Opens a menu of Tune & Listen demod softkeys. Tune & Listen can be set when you are in Analog Demodulation mode, so you can enable Tune & Listen sweeps in between your Analog Demod sweeps. To learn more about the Tune & Listen softkey menu choices, refer to **"Tune & Listen (AM/FM)" on page 166**.

See also, **"How to make Analog Demodulation (Metrics) Settings" on page 173**.

### How to make Analog Demodulation (Metrics) Settings

The following softkeys are available when one of the Analog Demodulation metrics measurements is pressed. See also, **"How to select Tune & Listen" on page 167**.

If **AM DSB**, choose from:

- **AM Top Y** – Determines the Y axis percentage (0% to  $\pm 100\%$ ) of the AM demodulation waveform is displayed (Default = 100%).

If **AM SSB**, choose from:

- **SSB Top Y** – Determines the Y axis voltage (0 nV to  $\pm 100\text{mV}$ ) of the AM SSB demodulation waveform is displayed (Default = 100 mV).

If **FM**, choose from:

- **FM Top Y** – Determines the Y axis frequency (1 kHz to 1 GHz) of the FM demodulation waveform is displayed (Default = 100 kHz).

If **FM Stereo / RDS**, choose from:

- **FM Top Y** – Determines the Y axis frequency (1 kHz to 1 GHz) of the FM demodulation waveform is displayed (Default = 100 kHz).

If **PM**, choose from:

- **PM Top Y** – Determines the Y axis phase (0 to 100 radians) of the PM demodulation waveform is displayed (Default = 5).

For any of the following: **AM DSB**, **AM SSB**, **FM**, **FM Stereo / RDS**, or **PM**, choose from:

Refer to **Figure 9-5 on page 179**, **Figure 9-6 on page 179**, **Figure 9-7 on page 180**, and **Figure 9-8 on page 180**.

- **Demod SwpT** – Sets the X-axis to display the demodulation sweep time for the demodulated waveform (minimum = 50  $\mu$ s; maximum = 50 ms).
- **Peak OFF ON** – This adds peak positive and peak negative metrics to the main metrics measurement. For example, in FM peak ON will include peak positive (Peak +) and negative (Peak -) frequency deviation metrics to appear. Peak ON will also enable peak traces on the demodulation waveform and audio frequency spectrum (Default = OFF).
- **Demod Type** – Sets the demodulation type.  
Choose from **AM**, **AM SSB**, **FM**, **FM Stereo / RDS**, and **PM**.
- Then, press **More** – opens a menu of softkeys: **Average Type**, **Average Count**, and **Demod View Time Freq**.
- **Average Type** – Selects the way the demodulated signal values are averaged. Choices are Power (#PAvg annotation is displayed), Log (#LgAv annotation is displayed), Voltage (#VAvg annotation is displayed). Auto is the default and when selected the FieldFox chooses the type of averaging that is used based on the current settings.
- **Average Count** – Determines the amount of averaging used (1 to 10K; Default = 10).
- **Demod Filters** – Refer to “**How to Set the Demod Filters**” on page 177.
- **Demod View Time Freq** – Toggles how the demodulated signals are displayed (Time (waveform) or Frequency (spectrum)); Default = Time).
- **Audio Capture Playback** – Refer to “**Setting the Audio Capture Playback Softkeys**” on page 175.

### Setting the Alternate Frequency (AF) Freq/Dist Softkeys

When **AM DSB**, **AM SSB**, **FM**, **FM Stereo / RDS**, or **PM** are selected and **Demod View = Freq**, you can choose from the following:

- Press **Freq/Dist** then choose:
- **AF Start Freq** – Sets the AF start frequency for the AM or FM demodulated signal.

- **AF Stop Freq** – Sets the AF stop frequency for the AM or FM demodulated signal.
- **AF Full Span** – Sets the AF full span frequency for the AM or FM demodulated signal.

Also, you can set the standard Center, Freq Span, and other frequency softkeys.

### Setting the Alternate Frequency (AF) RBW Softkey

When **AM DSB**, **AM SSB**, **FM**, **FM Stereo / RDS**, or **PM** are selected and **Demod View = Freq**, you can choose from the following:

- Press **BW 2** then choose:
- **AF RBW** – Sets the audio frequency (AF) resolution BW for the AM or FM demodulated signal (Manual or Auto; default = Auto).

### Setting the Audio Capture Playback Softkeys

The FieldFox analog demodulation audio capture playback feature allows you to capture/record the demodulated audio associated with an analog demodulation measurement (AM DSB, AM SSB, FM, FM Stereo or PM) and save it as an audio file. It also allows you to recall and playback audio files through FieldFox's built-in speaker or headphones.

#### NOTE

Currently, the audio capture playback feature supports WAVE files with mono or stereo LPCM data sampled at 48,000 Hz with 16 bits per sample.

If you are unable to hear your audio data files (\*.wav), verify that your **System > Preferences > Preferences > Audio** is set to On.

When **Analog Demod** is selected, you can choose from the following:

- Press **Meas Setup 4** > **More** > **Audio Capture Playback** then
- If you want to initiate an audio capture:  
Press **Capture**
- If you want to stop an audio capture:  
Press **Stop** to stop the current capture of audio data and depending on the timing of pressing Stop, possibly prevent the audio data from being stored.
- If you have previously stored an audio file:  
Press **Playback** then
  - **Play** – to play the last current audio file (\*.wave) loaded into memory.
  - **Stop** – to disable playback of the current audio file.

- **Volume 0** – to enable/disable volume and to adjust the volume from 0 to 100 (default = 50).
- **Load Audio File** – to load a previously stored audio (.wav) file.
- **Cap Auto-Load File** – enable/disable automatically loading of a captured audio (.wav) file (default = OFF).
- Press **Capture Settings** then
  - **Capture Count** – sets the number of audio captures for a measurement (Default = 1; Settable: 1 to 10K).
  - **Capture Time** – sets the capture time (Default = 100 ms). Minimum/Maximum capture times vary with other settings.
  - **Stereo Channel** – When **Demod Type = FM Stereo / RDS**, this softkey sets the type of audio to be captured and stored: (Choose single channel: **Mono (L+R)**, **Left (L)**, **Right (R)**, and **Difference (L-R)**). Or choose two channel: **Stereo (L&R)**. Default = Mono (L+R).

Then Choose:

<b>Mono (L+R)</b>	Sets the audio recording to Mono (single channel) and combining left and right speaker sounds. This is the default.
<b>Stereo (L&amp;R)</b>	Sets the audio recorded to be stereo (two channels).
<b>Left (L)</b>	Sets the audio to be recorded to be the left speaker only.
<b>Right (R)</b>	Sets the audio to be recorded to be the right speaker only.
<b>Difference (L-R)</b>	Sets the audio to be recorded to be the value of the left side minus the right side of the audio data (single channel).

- Then **File Settings** then
  - **Filename** – Opens the filename labeler to specify a filename.
  - **Timestamp OFF ON** – Enables/disables a timestamp label on your audio (.wav) filename.
  - **Storage Device** – Sets the storage device location for your audio (.wav) file. Select **Internal** (default), **SD Card**, or **USB**.

For more on file settings refer to **Chapter 32, “File Management.”**

## How to Set the Demod Filters

The demodulation (Demod) filters and de-emphasis options help you accurately recover and analyze the modulating signal. The demod filters apply to all demod types (AM DSB, AM SSB, FM, FM Stereo and PM), while the de-emphasis options only apply to the FM and FM stereo demod types.

- Press **Filters** then
  - **Lowpass Filter None** – then choose:

<b>None</b>	No lowpass filter is selected.
<b>300 Hz</b>	5-Pole Butterworth LPF with 3 dB cutoff frequency of 300 Hz.
<b>3 kHz</b>	5-Pole Butterworth LPF with 3 dB cutoff frequency of 3 kHz.
<b>15 kHz</b>	5-Pole Butterworth LPF with 3 dB cutoff frequency of 15 kHz.
<b>30 kHz</b>	3-Pole Butterworth LPF with 3 dB cutoff frequency of 30 kHz.
<b>80 kHz</b>	3-Pole Butterworth LPF with 3 dB cutoff frequency of 80 kHz.
<b>100 kHz</b>	3-Pole Butterworth LPF with 3 dB cutoff frequency of 100 kHz.
<b>20 kHz</b>	9-Pole Bessel LPF with 3 dB cutoff frequency of 20 kHz.
<b>300 kHz</b>	3-Pole Butterworth LPF with 3 dB cutoff frequency of 300 kHz.
<b>Custom</b>	5-Pole Butterworth LPF with a custom 3 dB cutoff frequency (determined by the LPF 3 dB Cutoff setting).

- **LPF 3 dB Cutoff 300.000 Hz** – When the Lowpass filter is set to **Custom**, sets the customized LPF 3 dB cutoff frequency for the lowpass filter (Default = 300 Hz; Minimum = 90 Hz, Maximum = 5 MHz).
- **Highpass Filter None** – then choose:

<b>None</b>	No highpass filter is selected.
<b>20 Hz</b>	2-Pole Butterworth HPF with 3 dB cutoff frequency of 20 Hz.
<b>50 Hz</b>	2-Pole Butterworth HPF with 3 dB cutoff frequency of 50 Hz.

<b>300 Hz</b>	2-Pole Butterworth HPF with 3 dB cutoff frequency of 300 Hz.
<b>400 Hz</b>	10-Pole Butterworth HPF with 3 dB cutoff frequency of 400 Hz.
<b>Custom</b>	5-Pole Butterworth HPF with a custom 3 dB cutoff frequency (determined by the HPF 3 dB Cutoff setting).

- **HPF 3 dB Cutoff 500.000 Hz** – When the Highpass Filter is set to **Custom**, sets the customized HPF 3 dB cutoff frequency for the highpass filter (Default = 500 Hz; Minimum = 20 Hz, Maximum = Varies, depending on the AF Span).
- **Bandpass Filter None** – Sets the Bandpass Filter for the current measurement (Choices: None, CCITT, A-Weighted, C-Weighted, C-Message, CCIR-1k Weighted, CCIR-2k Weighted, or CCIR Unweighted). Default = None.
- **More** – **FM and FM Stereo only**. Opens a softkey menu to enable/disable the De-Emphasis softkeys.
  - **De-Emphasis OFF ON** – Enables/disables the de-emphasis applied to the demodulated signal.
  - **De-Emphasis T** – Sets the amount of de-emphasis applied to the demodulated signal.

### Setting the Marker Counter Gate Softkey

When **AM Metric** or **FM Metric** are selected, you can choose from the following:

- Press **Marker** > **Peak**
- Press **Mkr->/Tools** > **More** > **Mkr Properties** > **Counter Gate** – Sets the AM or FM Tune & Listen demodulated signal’s counter window time (Minimum = 1 ms and Maximum = 2s; default = 100 ms).

The Counter Gate softkey is **not** available when AM Tune & Listen, FM (narrow) Tune & Listen, or FM (wide) Tune & Listen are enabled. Refer to **Figure 9-8 on page 180**.

See also, **“How to use Marker Functions” on page 713**.

Figure 9-5 AM DSB (Metrics) – Demodulation Waveform

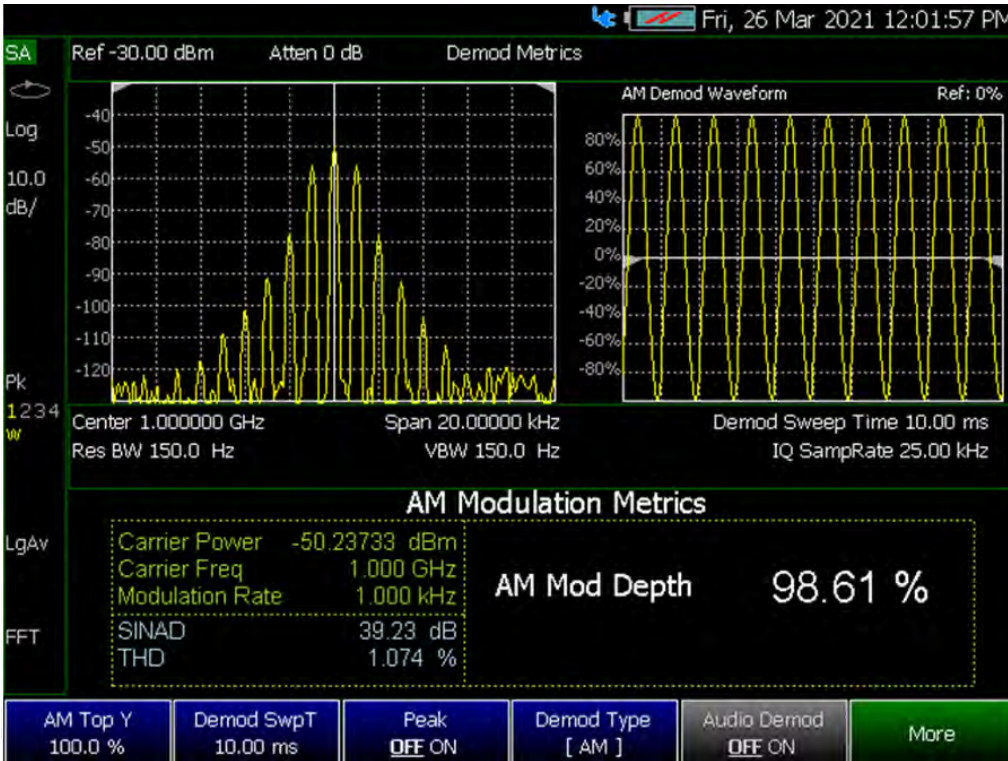

Figure 9-6 FM Metrics – Demodulation Spectrum

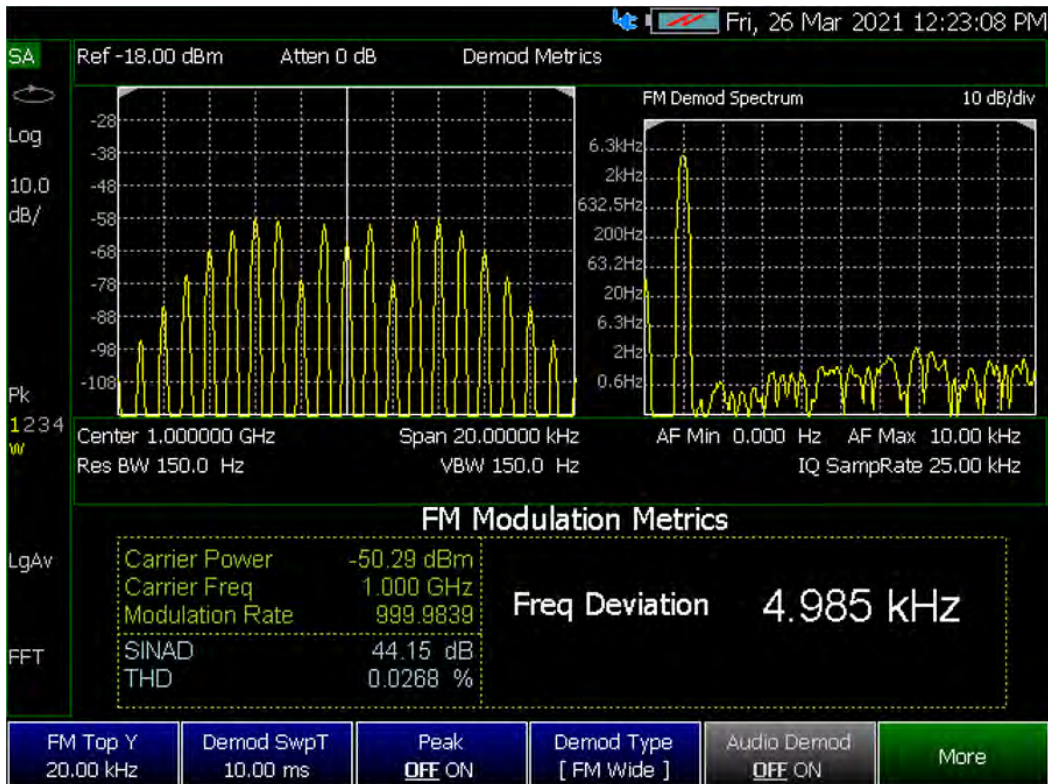

Figure 9-7 FM (Metrics) – Demodulation Waveform

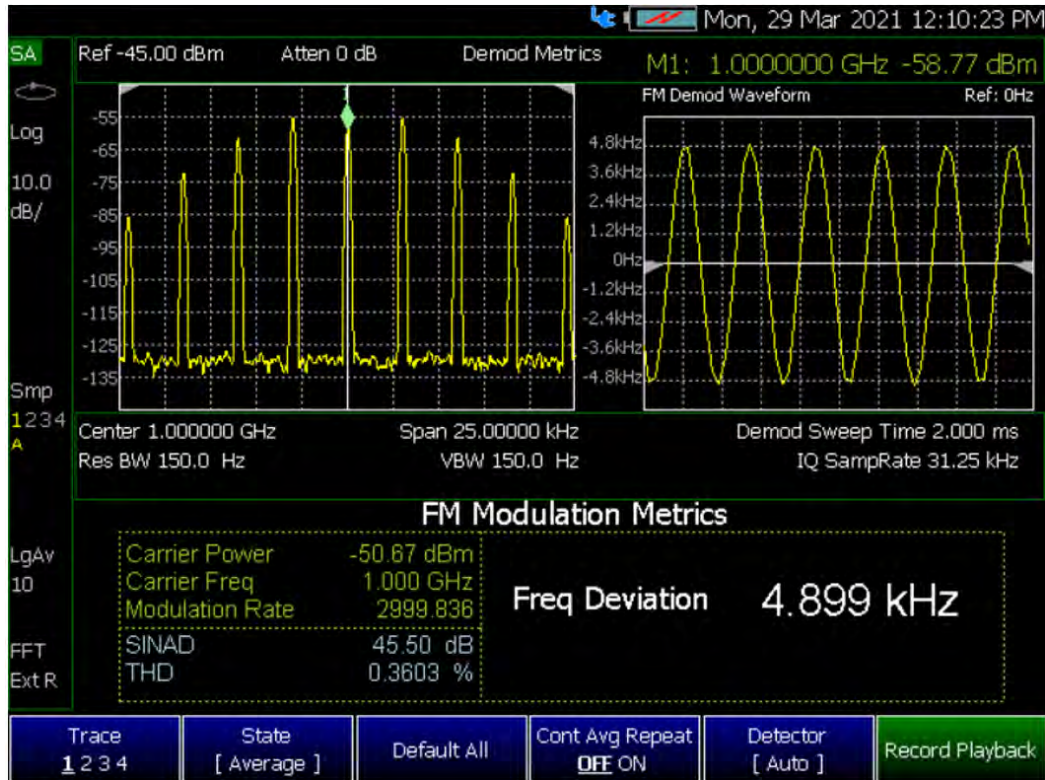
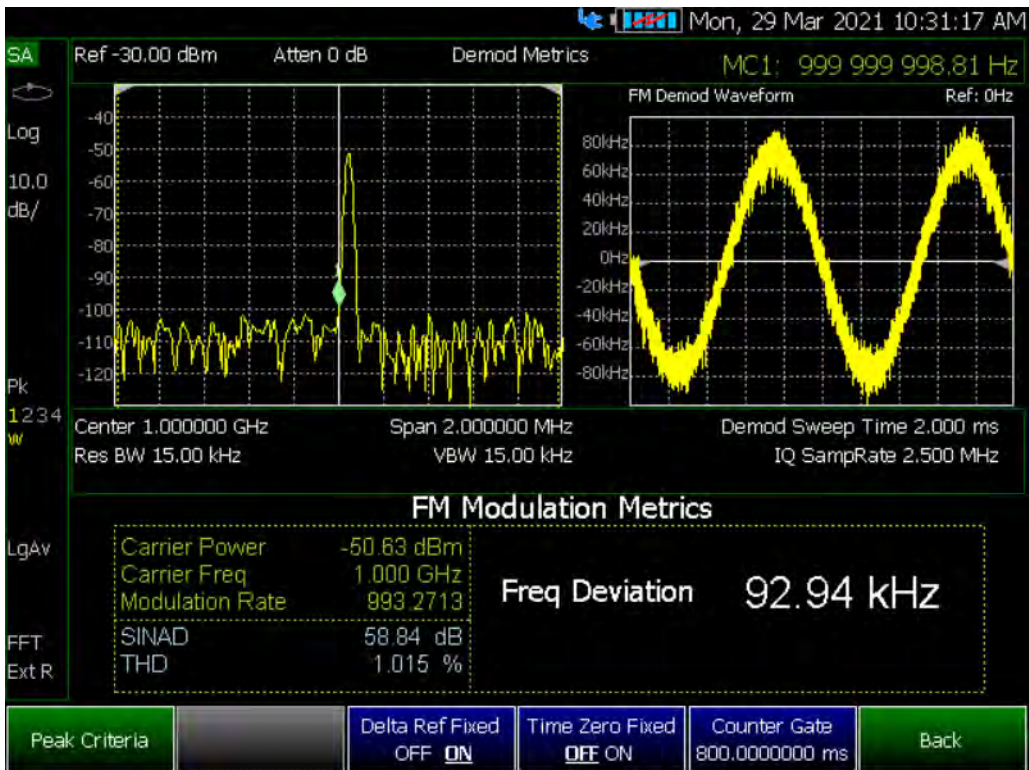

Figure 9-8 FM (Metrics) – Counter Gate and FM Demodulation Waveform



## Independent Source/Tracking Generator

### NOTE

For best results, when using the independent source feature, InstAlign and the battery saver features should be turned off. Refer to “How to Access Individual Alignments” on page 205 and “Preferences” on page 740.

This feature may require an option. For a comprehensive list, view the FieldFox Configuration Guide at:

<https://www.keysight.com/us/en/assets/7018-06515/configuration-guides/5992-3701.pdf>

A tracking generator, a popular option with Spectrum Analyzers, is a source which always tracks the SA receiver.

Like a traditional tracking generator, the Independent Source feature can set the internal FieldFox source to track the SA receiver frequency range. It can also set the internal source to a CW frequency that is independent of the SA frequency.

Independent Source can be enabled ONLY when the FieldFox is in SA mode.

To view the internal source, you must connect a cable or device between the RF Output connector and the RF Input connector.

### How to make Independent Source Settings

- Press **Measure 1** > **Source**
- **Source Enable ON OFF**
  - **ON** Turns ON the internal source.
  - **OFF** Turns OFF the internal source.
- **Source Mode** Choose from the following:
  - **Tracking** The internal source frequency can track the SA receiver. Center frequency **Src** is annotated on the screen
  - **CW** The source is set to a CW frequency independent from the SA settings. **Srcw** is annotated on the screen.
  - **Coupled CW** The source is set to a CW frequency, but that frequency “tracks” the SA receiver Center Frequency settings. Therefore, the signal always appears at center of the display. **Srcp** is annotated on the screen.
- **Normalize ON OFF** With Source Enable ON and Source Mode = Tracking, Normalize ON stores the current measurement trace into Trace 4 in View state as a reference trace. All subsequent trace measurements subtract this Trace 4 reference trace, and therefore become relative to it. **SrcN** is

annotated on the screen. Normalize is automatically turned OFF when the frequency range or Resolution is changed. Learn more about Trace Display States in [“Trace Display States \(SA Mode\)” on page 198](#).

- **Source Power** Sets the source power level. Choose from:
  - **Leveled** Enter a value from –50 dBm to 3 dBm using the numeric keypad, **▲▼** arrows, or the rotary knob<sup>1</sup>. The source power is reasonably flat across the frequency span.
  - **MAX** The power level is set to the maximum achievable power level at each frequency. This results in the power level NOT being flat across the frequency span.
- **Source CW Freq** Sets the CW frequency that is used when Source Mode is set to CW.

#### NOTE

By default, the source output will turn off momentarily at the end of each IQA and SA sweep and also every 300 seconds during the InstAlign process.

To cause the source to stay ON at the end of each sweep, turn battery saver OFF. (Learn more in [“How to Access Individual Alignments” on page 205](#).)

- Press **System 7** > **Preferences** > **Preferences** then
- In the table, select Battery Saver. Press **Edit** then **Battery Saver ON OFF**  
To suspend InstAlign: (Learn more in [“How to Access Individual Alignments” on page 205](#).)
- Press **Cal 5**
- Then **Amptd Alignment OFF**

## Resolution Bandwidth (Res BW)

In SA Mode, the Res BW provides the ability to resolve, or see closely spaced signals. The narrower (lower) the Res BW, the better the spectrum analyzer can resolve signals. In addition, as the Res BW is narrowed, less noise is measured by the spectrum analyzer ADC and the noise floor on the display lowers as a result. This allows low level signals to be seen and measured. However, as the Res BW is narrowed, the sweep speed becomes slower. See [“Very Long Sweep Times” on page 190](#).

### How to set Res BW

- Press **BW 2**.
- Then **Res BW**.
- Then choose from the following:

1. N995xB/6xB cannot have the Leveled value set lower than –35 dBm.

– **Auto** Res BW is coupled to the frequency span. As the frequency span is narrowed, the Res BW is also narrowed providing increased ability to resolve signals.

To change this setting from **Man** to **Auto**, press **Res BW** twice.

– **Man** Enter a Res BW value using the numeric keypad, the **▲▼** arrows, or the rotary knob. Then press a multiplier if necessary or press **Enter**.

The current Res BW setting is shown at the bottom of the screen.

**#Res BW x.xx XHz (#)** means manual setting.

This setting could impact the accuracy of the measurement. See Specifications in Appendix B.

**NOTE**

The Res BW setting also affects the Sweep Type setting. Learn how in “Sweep Type” on page 184

## Video Bandwidth (Video BW)

Video BW is a smoothing operation that is performed after measurement data is acquired. The trace data is effectively smoothed so that the average power level of the displayed noise is the same, but the peaks and valleys of adjacent data points are smoothed together. More smoothing occurs as the Video BW is set lower. However, as the Video BW is narrowed, the sweep speed becomes slower.

### How to set VBW

– Press **BW 2**.

– Then **Video BW**

– Then choose from the following:

– **Auto** Couples Video BW to the ResBW in a 1-to-1 ratio.

– **Man** Enter a Video BW value using the numeric keypad, the **▲▼** arrows, or the rotary knob. Then press a multiplier if necessary or press **Enter**. Setting VBW higher than RBW may smooth the trace.

**NOTE**

To change this setting from Man to Auto, press Video BW twice.

The current Video BW setting is shown at the bottom of the screen.

**# VBW x.xx XHz (#)** means manual setting.

When the Res BW/Video BW ratio exceeds 10,000, a **Meas UNCAL** warning may appear to indicate that the Video BW filter has reached the maximum capacity for averaging.

## AF RBW (Audio-Frequency Resolution BW)

AF RBW - sets the audio-frequency resolution bandwidth for the selected frequency (Default = Auto).

### How to set AF RBW

- Press **BW 2** > **AF RBW**
- Then choose from the following:
  - **Auto** Couples AF BW to the Resolution BW in a 1-to-1 ratio.
  - **Man** Enter a AF BW value using the numeric keypad, the **▲▼** arrows, or the rotary knob. Then press a multiplier if necessary or press **Enter**. Setting AF BW higher than RBW may smooth the trace.

#### NOTE

To change this setting from Man to Auto, press AF RBW twice.

The current AF RBW setting is shown at the bottom of the screen.

# **AF RBW x.xx XHz** (#) means manual setting.

When the Res BW/AF RBW ratio exceeds 10,000, a **Meas UNCAL** warning may appear to indicate that the AF RBW filter has reached the maximum capacity for averaging.

## Sweep Type

In SA mode, the FieldFox uses two sweep types to process inputs signals. The sweep type that is currently being used (**FFT** or **Step**) is displayed in the lower-left corner of the FieldFox screen.

For a more comprehensive tutorial, see Spectrum Analysis Basics (App Note 150) at

<https://www.keysight.com/us/en/assets/7018-06714/application-notes/5952-0292.pdf>

### How to set Sweep Type

- Press **BW 2**.
- Then **Advanced**
- Then **Sweep Type**
- Then choose from the following:
  - **Auto** The FieldFox selects the most efficient sweep type based on the Res BW. When Res BW is set to 200 kHz and below, FFT sweep type is selected. Above 200 kHz, Step sweep type is being performed.
  - **FFT** The FieldFox uses FFT sweep type regardless of the Res BW.

- **Step** The FieldFox uses Step sweep type regardless of the Res BW. This is useful for capturing impulsive noise that may be generated from nearby electrical equipment.

## Oversweep

In SA mode, the FieldFox uses Oversweep to quickly analyze input signals. Oversweep is meant to verify that your setup is correct, but Oversweep is **not** meant to be as accurate as **FFT** and **Step** sweeps. See also, “**How to set Sweep Type**” on page 184.

### How to set Oversweep

- Press **BW 2** > **Advanced** then
- Press **Oversweep** – To enable/disable the Oversweep. Over sweep enables you to quickly evaluate your setup.

## IF Output

The FieldFox IF (intermediate frequency) can be output for external signal processing. The signal is available from the IF Out connector on the FieldFox right-side panel. See the connector in “**Right Side Panel**” on page 42.

The IF Out signal, centered at approximately 33.75 MHz (Narrow) or 225 MHz (with Wide path Option B04 or Option B10), is simply a down-converted version of the RF Input signal that is present at the tuned frequency.

While outputting an IF signal, the FieldFox stops performing the InstAlign process. Therefore, the amplitude of traces on the FieldFox screen is NOT accurate and **Meas UNCAL** appears on the screen to indicate this. Learn more in “**Individual Alignments**” on page 204. See also **Figure 9-9** on page 186.

Learn more about the IF Output frequencies and bandwidths in the Supplemental Online Help:

<http://na.support.keysight.com/fieldfox/help/SupHelp/FieldFox.htm>

Figure 9-9

IF Output Wide with CF=225 MHz (Requires Option B04 or Option B10)

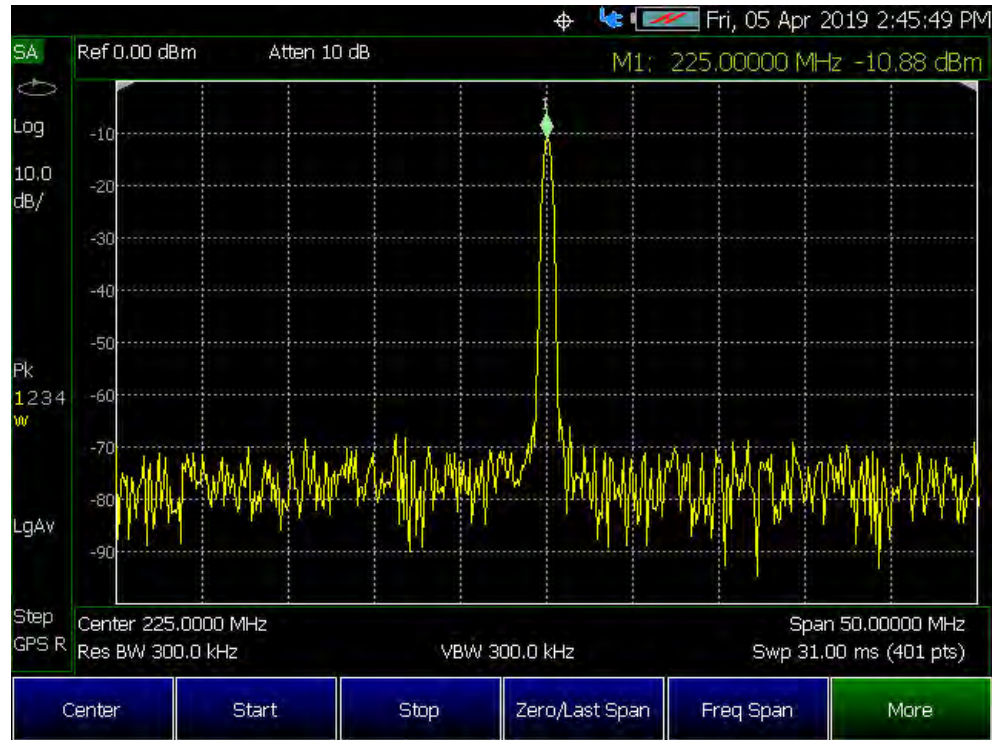

### How to select IF Output

The IF Output signal is useful only in Zero Span. Learn more about Zero Span in [“Zero Span Measurements” on page 190](#).

At least one sweep must be made in order to tune the FieldFox.

- Press **BW 2**.
- Then **Advanced**
- Then **IF Output Use**
- Then choose from the following:
  - **OFF** The translated IF signal at the IF OUT connector is no longer guaranteed to be centered at 33.75 (Narrow) or 225 MHz (Wide). Requires Option B04 or B10 respectively.
  - **Narrow** The IF output signal has approximately 10 MHz bandwidth.
  - **Wide** Requires B04 or B10. The IF output signal has approximately 100 MHz bandwidth with either B04 or Option B10.

Figure 9-10 SA Display Wide BW IF Out - Center Frequency 4 GHz (Requires Option B10)

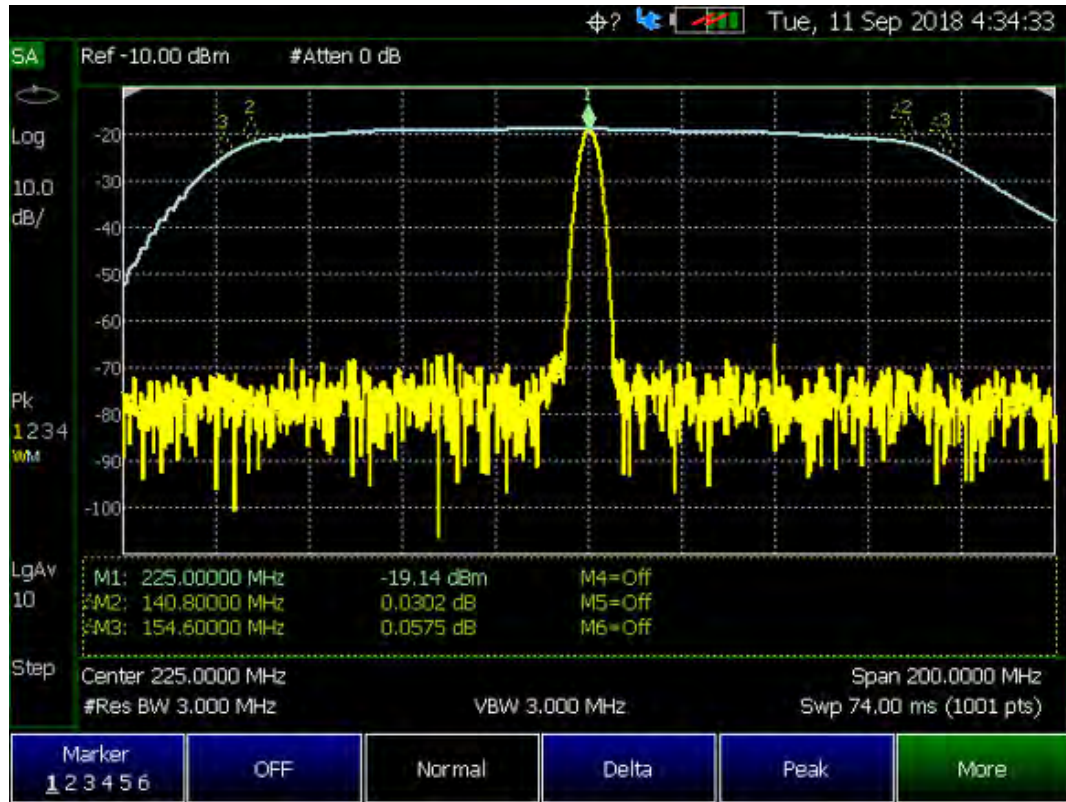
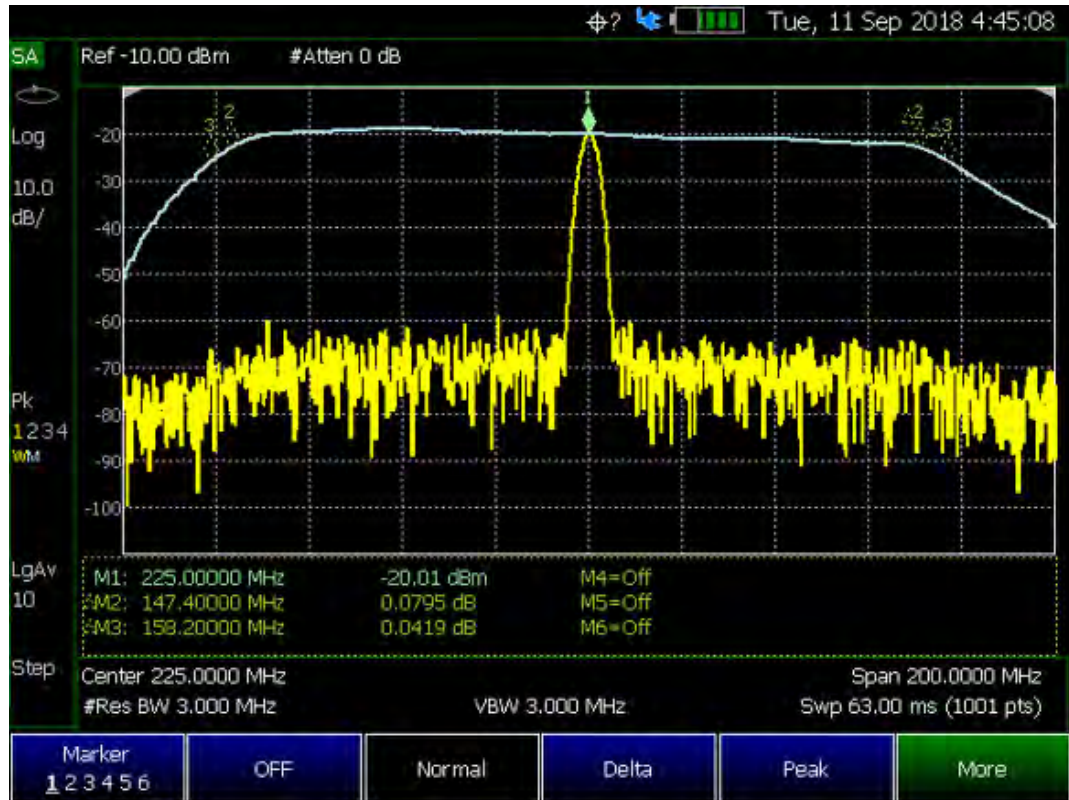

Figure 9-11 SA Display Wide BW IF Out - Center Frequency 10 GHz (Requires Option B10)



## Sweep Acquisition

Available only in non-zero span measurements, when Sweep Acquisition is set to Auto, the fastest sweep rate is achieved while maintaining full amplitude accuracy.

### NOTE

For zero span measurements, refer to **“Zero Span Measurements” on page 190.**

However, you can adjust this setting in order to increase the probability of intercepting and viewing pulsed RF signals.

For example, with **SwpAcquisition set to Auto** a pulsed GSM signal is NOT visible on the FieldFox screen, as shown in a blue trace in the following image.

While watching the trace, increase the SwpAcquisition value until the pulse spectrum rises out of the noise and reaches its maximum level. Increasing the SwpAcquisition value beyond this point only slows the update rate (increases the actual Sweep time readout) but does not improve measurement quality.

Figure 9-12 GSM Signal in Framed Data Format

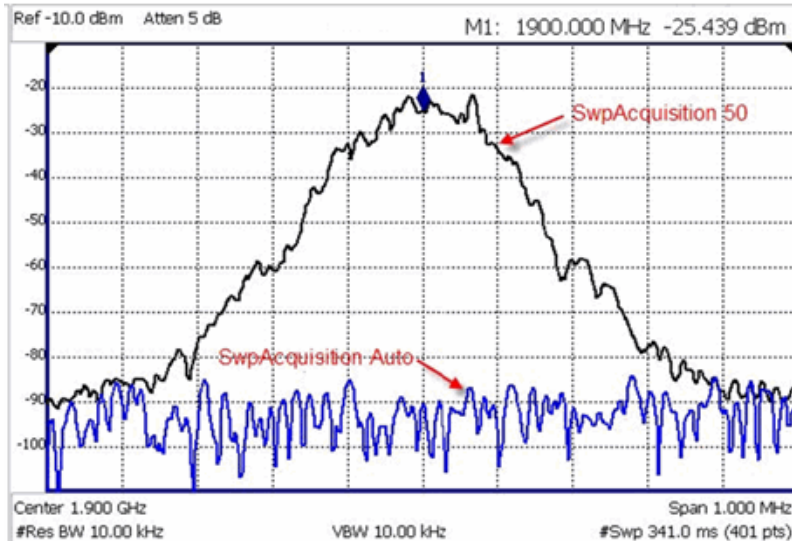

In the graphic above, a GSM signal in a framed data format; timeslot zero ON; all others OFF; PRF = 218Hz, Duty Cycle = 12.5%. The pulsed signal becomes visible on every sweep update with SwpAcquisition = 50.

### How to set Sweep Acquisition

SwpAcquisition is NOT an absolute measure of time, but a relative number between 1 (fastest) and 5000 (slowest) sweep time. The actual time that was required to complete a sweep is annotated on the screen.

- Press **Sweep 3**.
- Then **SwpAcquisition Auto Man**.
- Then choose from the following:
  - **Auto** Sweep is set to the fastest sweep possible with the current settings.
  - **Man** Enter a relative acquisition value between 1 and 5000, where:
    - 1 = Fastest sweep possible
    - 5,000 = Slowest sweep possible
    - # is shown in front of the actual sweep time to indicate a manual setting.

Some Detector and Video Bandwidth settings will raise the Auto Sweep Acquisition value greater than 1. In these cases, manually setting Sweep Acquisition lower than the Auto value may have NO effect.

**NOTE**

**Measurement speed specifications do NOT apply in Temperature Control Mode. Learn more in “Temperature Control Mode” on page 33.**

---

Learn more about SA mode SwpAcquisition time in the Supplemental Online Help: <http://na.support.keysight.com/fieldfox/help/SupHelp/FieldFox.htm>

## Very Long Sweep Times

Two primary settings are responsible for the sweep time: Res BW and SwAcquisition.

- When the sweep time exceeds 1200 seconds (20 minutes), an informational message: **Alert: Very long sweep in progress...** is annotated on the screen for the duration of the sweep.
- When the sweep time exceeds 4000 seconds (about 1 hour), **Meas UNCAL** is annotated on the screen. Accuracy cannot be guaranteed.
- InstAlign is always performed only at the beginning of the sweep regardless of the sweep time. Learn more in “How to Access Individual Alignments” on page 205.

## Zero Span Measurements

When setting the frequency span to Zero, there is NO spectrum of frequencies to display, so the X-axis units becomes Time. The SA becomes like a tunable oscilloscope, with the center frequency being the frequency of interest. This capability is useful for analyzing modulation characteristics, such as pulsed measurements.

**NOTE**

**For non-zero span measurements, refer to “Sweep Acquisition” on page 188.**

---

Figure 9-13 GSM Signal, Framed Data Format

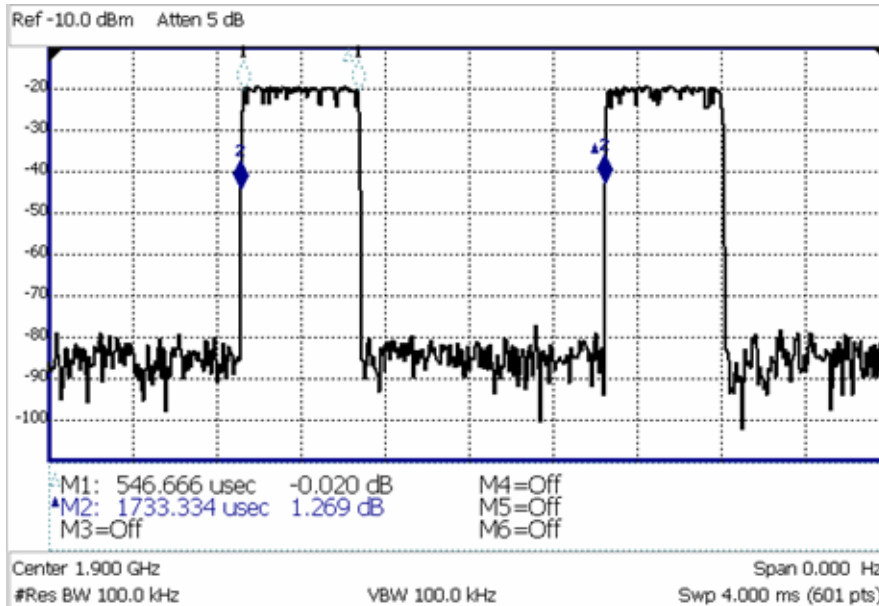

The graphic above shows a GSM signal, framed data format, with timeslot 0 and 3 “on”. Sweep Time is set to approximately the frame interval. Press Single several times until the waveform section of interest is viewable and stable. Then markers can be used to measure the timeslot width and interval as shown.

### How to set Zero Span

- Set **Center** to the frequency of interest
  - then set **Span** to 0 Hz
  - or select **Zero/Last Span**. Each key press toggles the frequency span between 0 Hz and the last specified frequency span.

### How to change Sweep Time in Zero Span

- Press **Sweep 3**
- Then **Sweep Time**
- Enter a value using the numeric keypad. Sweep time is limited to 1000 seconds for N991xB/2xB/3xB models.
- Then select a multiplier key. Learn more in **“Multiplier Abbreviations” on page 46**.

Learn more about SA mode Sweep Time in the Supplemental Online Help:  
<http://na.support.keysight.com/fieldfox/help/SupHelp/FieldFox.htm>

## Triggering

External, Video, and RF Burst triggering allows you to initiate an SA mode sweep using an external event such as a signal burst.

All three trigger types can be used in either Zero Span (time domain) or FFT frequency sweeps. Learn more in [“Zero Span Measurements” on page 190](#). Learn more in [“Sweep Type” on page 184](#).

FFT Gating is available for non-zero span measurements. Learn more about FFT Gating in [“FFT Gating \(Opt 238\)” on page 196](#).

### Trigger Type

- Press **Sweep 3** > **Trigger Settings** > **Trig Type**
- Then choose from the following:
  - **Free Run** Triggering is provided by the FieldFox internal circuitry. A new sweep begins when the previous sweep ends.
  - **External** A sweep is triggered on an external TTL signal at the Ref In/Trig In connector on the FieldFox top panel. Choose to trigger on the rising slope at about 1.7 V or on the falling slope at about 1.0 V using the Trigger Slope setting (below).
  - **Periodic** sets a trigger that repeats at the period rate entered. Periodic trigger's phase can be altered by the Offset value.

The following two selections are similar in that they both trigger a sweep from a signal at the **SA RF Input** connector. Experiment with both selections to find the best trigger type for your application.

- **Video** A sweep is initiated when the displayed amplitude of an incoming signal crosses the settable Trigger Level. This selection can detect low-amplitude signals, but also has been filtered considerably and may not be a true representation of the incoming signal.
- **RF Burst** A sweep is initiated when the signal at the third IF (analog) stage crosses the settable Trigger Level. This selection offers a wider bandwidth and may be a better representation of the incoming signal than Video trigger. However, RF Burst is not as sensitive to triggering on low-level signals.

### Sync

#### NOTE

This softkey is **ONLY** available when **Trigger Type** is set to **Periodic**.

Selects the type of signal the periodic trigger is synchronized.

- **None** No synchronization is selected for a Periodic trigger.

- **External** A sweep is triggered on an external TTL signal at the Ref In/Trig In connector on the FieldFox top panel. Choose to trigger on the rising slope at about 1.7 V or on the falling slope at about 1.0 V using the Trigger Slope setting (below).
- **RF Burst** uses an alignment process which is performed in the background to set the detected signal level accuracy. Learn more in “**RF Burst Amplitude Alignment**” on page 206.
- **1 PPS GNSS** Periodic trigger is synchronized to a 1 pulse per second GNSS signal.

## Trigger Slope

### NOTE

This softkey is unavailable when **Trigger Type** is set to **Periodic**.

Trigger Slope determines which edge of an External, Video, or RF Burst trigger signal initiates a sweep.

- Press **Sweep 3**
- Then **Trigger Settings**
- Then **Trig Slope**
- Then choose from the following:
  - **Pos** Sweep is triggered by the rising (positive) edge of signal.
  - **Neg** Sweep is triggered by the falling (negative) edge of signal.

## Trigger Delay

After a valid trigger signal is received, the sweep begins after the specified Trigger Delay time.

To see the rising edge of a repetitive signal which is triggered on that edge, enter a negative trigger delay value (also known as pre-trigger). Adjust the sweep time to observe the pre-trigger time if necessary.

- Press **Sweep 3**
- Then **Trigger Settings**
- Then **Trig Delay**
- Enter a value using the numeric keypad, the **▲▼** arrows, or the rotary knob.
- Then select a multiplier key or press **Enter**. Learn more in “**Multiplier Abbreviations**” on page 46.

In Zero span, you can use Trigger Position as an easy way to set Trigger Delay by positioning the trigger event on the FieldFox screen. See **“Triggering” on page 192**.

## Period

### NOTE

This softkey is **ONLY** available when **Trigger Type** is set to **Periodic**.

---

Sets the length of time in seconds before a waveform repeats. (default = 20.00 ms).

## Offset

### NOTE

This softkey is **ONLY** available when **Trigger Type** is set to **Periodic**.

---

Sets the periodic trigger offset. (default = 0.00 s)

## Trigger Level

Used with Video and RF Burst triggering, a sweep is initiated when an incoming signal crosses this level. The units depend on the Units setting. Learn more in **“Scale and Units” on page 157**.

**RF Burst Trigger Level** uses an alignment process which is performed in the background to set the detected signal level accuracy. Learn more in **“RF Burst Amplitude Alignment” on page 206**. **Video Trigger Level** is a zero span signal level comparison. Therefore, the sweep will trigger close to the displayed level in zero span measurements. In non-zero span measurements, processing can cause broadband signal energy to display at lower power levels than the originating time domain signal. Therefore, you may need to set the trigger level higher than the displayed level.

- Press **Sweep 3**
- Then **Trigger Settings**
- Then **Trig Level**
- Enter a value using the numeric keypad, the **▲▼** arrows, or the rotary knob.
- Then select a multiplier key or press **Enter**. Learn more in **“Multiplier Abbreviations” on page 46**.

## Auto Trigger Time

While waiting for a valid trigger signal, **Wait** is annotated in the top left corner of the FieldFox screen.

If a valid trigger signal is not received before the specified Auto Trig Time, a sweep will occur automatically.

Enter **0** to set Auto Trigger **OFF**. When Auto Trigger is OFF, the FieldFox does NOT sweep unless a valid trigger signal is received.

- Press **Sweep 3**
- Then **Trigger Settings**
- Then **Auto Trigger [current setting]**
- Enter an Auto Trig Time using the numeric keypad.
- Then select a multiplier key. See **“Multiplier Abbreviations” on page 46**.

## Trigger Position

Available ONLY in zero span measurements, this setting is an easy way to automatically set the Trigger Delay by positioning the trigger event (also known as T-zero) at any graticule along the X-axis. With T-zero in the center of the screen, you can zoom in and out by increasing or decreasing the sweep time. Using the Trigger Position and Sweep Time settings is a quick and efficient way to examine artifacts of a pulse, much easier than trying to set the Trigger Delay manually.

When Trigger Position is set to OFF, the Trigger Delay softkey is not available. The amount of Trigger Delay that is being used is displayed on the softkey. The Trigger Position is annotated on the screen. Learn how in the following section.

- Press **Sweep 3**
- Then **Trigger Settings**
- Then **Trig Position**. If Sweep Time is longer than 0.15 sec, this softkey is grayed out.
  - **ON**: The position of T-zero is set by the trigger delay.
  - **OFF**: Select, then enter a position value from 0 to 10 using the numeric keypad, the **▲▼** arrows, or the rotary knob.
    - **0**: T-zero occurs at the left graticule.
    - **5**: T-zero occurs at the center of the screen.
    - **10**: T-zero occurs at the far right graticule.
- Then press **Enter**.

## Trigger Settings Annotation

Trigger settings are annotated on the FieldFox screen as highlighted in **red** in the following image:

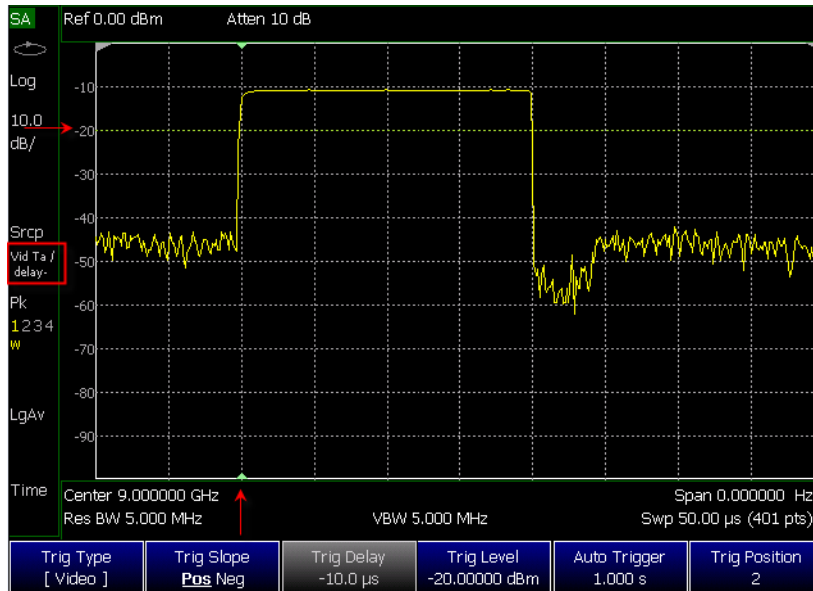

- Square: Trig Type (**VidT**), AutoTrigger (**a**), Pos Slope (**/**), Neg Delay (**delay-**)
- Horizontal arrow: Trig Level (green horizontal graticule at -20 dBm)
- Vertical arrow: Trig Position T-zero indicators (green arrows at 2nd vertical graticule)

## FFT Gating (Opt 238)

Time-gated spectrum analysis allows you to obtain spectral information about signals occupying the same part of the frequency spectrum that are separated in the time domain. Using an external trigger signal to coordinate the separation of these signals, you can perform the following operations:

- Measure any one of several signals separated in time; for example, you can separate the spectra of two radios time-sharing a single frequency.
- Measure the spectrum of a signal in one time slot of a TDMA system.
- Exclude the spectrum of interfering signals, such as periodic pulse edge transients that exist for only a limited time.

FFT Gating is a simple, efficient way to set the proper amount of trigger delay and capture time so that signal artifacts of a repeating waveform or pulse can be examined in the frequency domain. Learn more about trigger settings in **“Triggering” on page 192**.

For best results, Auto Trigger should be used with this feature to ensure that the sweep does not wait indefinitely for a trigger. Set Auto Trigger to a time that is longer than the expected periodic rate of the signal. This is especially

important when using RF Burst or Video triggering in wider spans, because the signal providing those triggers has limited bandwidth. Learn more about Auto trigger in **“Auto Trigger Time” on page 195**.

For more conceptual information on this topic, please refer to Spectrum Analysis Basics (App Note 150), pages 31 – 35, at <http://literature.cdn.keysight.com/litweb/pdf/5952-0292.pdf>.

## How to set FFT Gating

- Create a non-zero span measurement. Wider frequency spans take more time to acquire.
- Press **Sweep 3**
- Then **Trigger Settings**
- Then **FFT Gating Setup**
- Then choose from the following:
  - **Gate View OFF ON** When ON, a separate zero span measurement is displayed below the non-zero span window. The gate view measurement helps to configure the gate width and delay by revealing (with green markers) the location of the gate relative to the trigger event. The zero span measurement is tuned to the center frequency of the non-zero span measurement with about 5 MHz of bandwidth. The Y-axis scale is the same for both windows.
  - **Gate View Time** Set the X-axis span for the non-zero span window. Enter a value using the numeric keypad, the **▲▼** arrows, or the rotary knob. This value is annotated as Swp (nn) below the window.
  - **FFT Gating OFF ON** When ON, the trigger type, gate width, and delay are applied to the non-zero span measurement. The Res BW is set to a value that is inversely proportional to the gate width.
  - **Gate Width** Set the width of the gating area within the non-zero span window. The gating area is indicated by two vertical green lines. Enter a value using the numeric keypad, the **▲▼** arrows, or the rotary knob.
  - **Gate Delay** Effectively moves the gating area left (negative delay) or right (positive delay) relative to the trigger event. Enter a value using the numeric keypad, the **▲▼** arrows, or the rotary knob.

When you have properly setup the Gate Trigger, Width, and Delay using the Gate View measurement, you can turn **Gate View OFF** to return to the full screen non-zero span measurement with FFT Gating ON, the RBW set, and the Trigger settings active.

## Single / Continuous / Restart

This setting determines whether the FieldFox measures continuously or only once each time the **Single** or **Run / Hold +/-** button is pressed. Use **Hold / Single** or to conserve battery power or to allow you to save or analyze a specific trace.

### How to set Single or Continuous

- Press **Sweep 3**.
- Then choose one of the following:
  - **Continuous**
    - **ON** Causes the SA to make continuous sweeps. This is the typical setting for making measurements. Each **Run / Hold +/-** press causes the SA to toggle between continuous sweep and Hold.
    - **OFF** Causes the SA to Hold. Each **Run / Hold +/-** or **Single** press causes the SA to make ONE sweep, then Hold. The Hold annotation changes to an arrow --> while the sweep occurs.
  - **Single** Automatically sets Continuous OFF and causes the SA to make ONE sweep, then Hold.
  - **Restart** Resets the Average counter to 1. The Average counter also is used with MaxHold and MinHold Trace States. Learn more in **“Average Count” on page 200**.

## Points

Points is the number of measurements that are displayed along the X-axis. The higher number of data points, the better the ability to resolve closely spaced signals and the slower the sweep speed.

### How to set number of points

- Press **Sweep 3**
- Then **Points [current setting]**
- Then choose from:
  - **101 | 201 | 401 | 601 | 801 | 1001**
  - **# Points** to enter a trace points value manually (Maximum = 20001).

## Trace Display States (SA Mode)

- In SA Mode you can display up to four of the following types of trace states. All SA settings are applied to all displayed traces. See also **“Marker Trace (IQA and SA Mode)” on page 704**.

A color-coded legend for displayed traces is visible in the left pane of the SA mode screen:

**W** = Clear/Write; **M** = MaxHold; **m** = MinHold; **A** = Average; **V** = View

### How to display the Trace States

- Press **Trace 6**.
- Then **Trace 1,2,3,4** repeatedly to select a trace number to display or change its state. Traces are displayed in the following colors:
  - Trace 1 – **Yellow**      Trace 2 – **Blue**
  - Trace 3 – **Orange**      Trace 4 – **Green**
- Then **State [current setting]**
- Then choose from the following Trace States:
  - **Clr /Wr** (Clear/Write) Displays the actual measured data for each sweep.
  - **MaxHold** Displays the maximum response of the input signal at each data point over multiple sweeps. See also Average Count in **“Average Count” on page 200**.
  - **MinHold** Displays the minimum response of the input signal at each data point over multiple sweeps. See also Average Count in **“Average Count” on page 200**.
  - **Average** Each data point is averaged over multiple sweeps as set by the Average Count setting. Learn more in **“Average Count” on page 200**.
  - **View** Displays and then holds the last complete measurement trace on the screen. This is similar to storing a trace in memory.
  - **Blank** Displays no trace.
- Press **Default All** to return all traces to their default settings: Trace 1 (Clear/Write); all other traces (Blank).

#### NOTE

Trace 4 data WILL be overwritten by the FieldFox when using the Independent Source Normalize feature (**“Independent Source/Tracking Generator ” on page 181**) or using Field Strength antenna or cable corrections (**“Field Strength Measurements” on page 161**).

### Average Type

In SA Mode, there are four different processes in which Averaging is performed:

- Average Traces – Learn more in **“Averaging” on page 215**.
- Detection Method Averaging – Learn more in **“Detection Method” on page 208**.

- Noise Marker Averaging – Learn more in **“Noise Marker” on page 211**.
- Video BW filtering (for non–Zero Span measurements) – Learn more in **“Video Bandwidth (Video BW)” on page 183**.

There are three types of mathematical averaging that can be performed – Log, Linear, or Voltage (see **“How to set Average Type” on page 200**). Select ONE of these types and it is used for all of the above averaging processes.

### How to set Average Type

- Press **Meas Setup 4** then **Average Type [current setting]**
- Then choose from the following:
  - **Auto** – The FieldFox chooses the most appropriate type of averaging for the current settings. When Detection Method is set to Average, a Noise Marker is present, or a Channel measurement is active, then Power Average is ALWAYS selected. Otherwise, Log Average is selected.
  - **Log** Averaging – Best for displaying Trace Averaging. LgAv is shown on the left side of the FieldFox screen when selected.
  - **Power** (Linear) Averaging – Best for measuring true power levels. Used in Detection Average and Noise Marker Average. Mathematically, trace noise is 2.5 dB higher than when using Log Average. PAVg is shown on the left side of the FieldFox screen when selected.
  - **Voltage** Averaging – Converts the amplitudes to a magnitude unit before averaging (e.g., Volts, Amps, microVolts, milliVolts, etc.) **VAvg** annotation is displayed.

### Average Count

The Average Count setting is used mainly with the Average Trace State described in **“Trace Display States (SA Mode)” on page 198**. In this Trace State, the Average Count setting determines the number of sweeps to average. The higher the average count, the greater the amount of noise reduction.

When Trace (display) State is set to **Average**, **MaxHold**, or **MinHold**, the average counter is shown in the left edge of the screen below the Average Type.

For all three of these Trace States, when **Sweep 3 Continuous** is set to OFF, press **Restart** to reset the sweep count to 1, perform <n> sweeps, then return to **Hold**.

### How to set Average Count

- Press **Meas Setup 4**
- Then **Average Count**

- Enter a value from 1 to 10,000 using the numeric keypad, the  arrows, or the rotary knob.
- Press **Enter**

## Alignments

This section contains the following:

- [“Overview” on page 201](#)
- [“All Alignment and Align All Now” on page 203](#)
- [“Individual Alignments” on page 204](#)

### Overview

**All Alignment** or **Align All Now** corrects for receiver drift over temperature and time. SA measurement applications monitor changes in internal temperature and the time since last alignment update and trigger the need for a new update when the alignment becomes stale. The alignment is deemed stale after a significant change in temperature or a significant time elapsed from the last update. The temperature change and time duration necessary to trigger an alignment update is predetermined in the factory. Until the update is performed, annotation indicating “questionable amplitude” is displayed **AMPTD?**.

When **All Alignment** is enabled (by default) the FieldFox performs an alignment process using the internal RF source. Although some sweeps are delayed, measurement results are never disturbed.

If the Independent Source (tracking generator) is enabled for your measurement, it will be borrowed to perform the alignment. Again, the measurement results are not disturbed. Learn about the Independent Source in [“Independent Source/Tracking Generator ” on page 181](#).

The alignment process can be disabled. You may want to do this, for example, if you are analyzing the amplitude stability of a signal.

SA and all modes built on its infrastructure require three types of alignments:

- InstAlign Amplitude Alignment
- RF Burst Amplitude Alignment
- Channel Equalization

These are referred to as **Individual Align**.

All three or a subset of the individual alignments are required for each specific mode, depending on the type of measurement supported by it:

SA:

- InstAlign Amplitude Alignment

SA (Spectrum Analyzer) Mode (Option 233–Mixed Analyzers)  
SA Mode Settings

- RF Burst Amplitude Alignment

RTSA:

- InstAlign Amplitude Alignment
- WidePath Burst Trigger Alignment
- Channel Equalization

Channel Scanner:

- InstAlign Amplitude Alignment

EMI Measurements:

- InstAlign Amplitude Alignment
- WidePath Burst Trigger Alignment
- Channel Equalization

ERTA:

- InstAlign Amplitude Alignment

IQA:

- InstAlign Amplitude Alignment
- RF Burst Amplitude Alignment
- Channel Equalization

Built-in Power meter

- InstAlign Amplitude Alignment

Default settings and recommended use model for many applications:

- Coupled individual alignments
- Coupled state is Auto
- Individual alignments are not accessible via front panel soft-keys
- Individual alignments cannot be UnCoupled

For special cases, the individual alignments can be accessible via the front panel soft-keys using the Preference setting **SA - Individual Alignment Control > On/Off**. This enables a soft-key for access to **Individual Alignments** when this preference is set to ON: **Cal 5 > Individual Align**. For more refer to **“Preferences” on page 740**, in **Chapter 30** System Settings.

The individual alignments may be:

- Coupled (default) - when they are in the same state, or
- Uncoupled - when at least one of them is in a different state than the other ones
- Executed on demand, all of them, using the **Align All Now** softkey.

Each of the individual alignments:

- could be in one of three states:
  - **Off** - the alignment is not applied and is not updated automatically
  - **Auto** (default) - the alignment will be updated over time and temperature as needed, no user interaction required
  - **Hold** - the unit holds the alignment values from the last alignment-execution and does not execute another alignment automatically
- can be updated on demand using the corresponding **Align Now** soft-key. Refer to **“Individual Alignments” on page 204**.
- The **All Alignment** soft-key has the following functionality:
  - when the individual alignments are Coupled, the state of all of them can be changed simultaneously using the **All Alignment** soft-key sub-menus
  - when the individual alignments are UnCoupled, they will be coupled when using the **All Alignment** soft-key sub-menus and their state will be simultaneously changed accordingly

## All Alignment and Align All Now

### NOTE

**IMPORTANT!** It is recommended that you use **Align All Now**, because it includes the individual alignment InstAlign **Amptd Align Now**, as well as, **Burst Align Now**, and **ChanEQ Align Now**. But, if you would prefer to have manual control over the individual alignments, then refer to the **SA Individual Alignment Control** setting in **“Preferences” on page 740**, in **Chapter 30 System Settings**.

The notification **AMPTD?** displayed on screen means the InstAlign amplitude alignment or channel equalization is stale (if its state is Hold) and requires an update or it is in the OFF state. This situation does not occur when the respective alignment is in the Auto state. To clear this notification, press the Align All Now softkey.

---

## How to set All Alignment and Align All Now

- Press **Cal 5**
- Then **All Alignment [Auto]** (to enable or disable the All Alignment) – Default is Auto.
- or
- Then **Align All Now** (to manually perform an Align All Now.) This performs an alignment on all three individual alignments: Amptd Align Now, Burst Align Now, and ChanEq Now). Refer to **“Individual Alignments” on page 204**.
- Press **Enter**

If you want to disable the All Alignment [Auto], you can do so in the FieldFox preferences (i.e., you may want to do this, for example, if you are analyzing the amplitude stability of a signal).

Refer to the **SA Individual Alignment Control** setting in **“Preferences” on page 740**, in **Chapter 30** System Settings. See also, **“Individual Alignments”**.

## Individual Alignments

### NOTE

**IMPORTANT!** It is recommended that you use **All Alignment [Auto]** or **Align All Now** in lieu of the individual alignments (**Amptd Align Now**, **Burst Align Now**, and **ChanEQ Align Now**), because All Alignment [Auto] and Align All Now includes the individual alignment InstAlign **Amptd Align Now**, **Burst Align Now**, and **ChanEQ Align Now**. But, if you would prefer to have manual control over the individual alignments, then refer to the **SA Individual Alignment Control** setting in **“Preferences” on page 740**, in **Chapter 30** System Settings.

The Individual Alignment softkey is only available, when the preference SA - Individual Alignment Control is set to On in the FieldFox Preferences menu. Refer to **“Preferences” on page 740**, in **Chapter 30** System Settings.

---

## How to Access Individual Alignments

This section assumes access to individual alignments was activated using the FieldFox's system settings' Preferences. Once enabled, an **Individual Alignments** softkey is displayed. Refer to **“Preferences” on page 740**, in **Chapter 30 System Settings**.

- Press **Cal 5**
- Then **Individual Align**
- Then **Amptd Align Now** or
- Then **Burst Align Now** or
- Then **ChanEq Align Now**
- Press **Enter**

## How to make Amplitude Alignment settings

### NOTE

During continuous sweep (“acquisition” for IQA) operation, automatic Alignments will NOT interrupt the ongoing measurement, but when necessary, will occur opportunistically as settings are changed. When no automatic alignment updates occur, existing alignments can become stale over time and temperature drift, so a warning annotation on the left panel will light up indicating that alignments need updating.

SA, IQA, RTSA, and other modes use a proprietary amplitude alignment algorithm to make extremely accurate amplitude measurements over the full frequency range of the FieldFox.

These settings do NOT survive a Preset or Mode Preset.

- Press **Cal 5**
- Then **Individual Align**
- Then **Amptd Alignment**
- Then choose from the following:
  - **Auto** (Default setting) Alignments are required and are performed automatically, when necessary, at times when interrupting the RF Output is deemed acceptable. The alignment process is performed opportunistically when changes in settings require the measurement to stop momentarily and a significant time elapsed since the last alignment (predetermined in the factory) or the internal instrument temperature has changed sensibly (predetermined in the factory).

Some examples of the conditions when alignments occur are: This could be a Center frequency change, or it could be as simple as requesting a Single sweep. Also, unique alignments are required at different FieldFox receiver frequency bands, so even if the temperature hasn't changed, an alignment may be required when one changes the Center frequency.

If a needed alignment cannot be performed, the user is notified about questionable amplitude **AMPTD?**.

- **OFF** Alignments are not performed. The most recent alignment result is cleared. Only factory corrections are applied to SA Receiver measurements. Questionable amplitude **AMPTD?** is always displayed.
- **Hold** The alignment process is stopped, but the last alignment values are applied to subsequent sweeps.
- **Amptd Align Now** An alignment is performed immediately, thus updating (clearing) any questionable amplitude status. If the Mode was previously Off, it is changed to Hold.

**Amptd?** is annotated in the lower left corner of the FieldFox screen when amplitude alignment is questionable. This is always true when OFF, and is conditionally true in Auto or Hold when the most recent alignment is deemed stale.

## RF Burst Amplitude Alignment

RF Burst alignment calibrates the circuitry to provide accurate external RF Burst triggering. Learn more about RF Burst triggering in [“Triggering” on page 192](#)

When enabled (by default) the FieldFox performs an alignment process using the internal RF source. Although some sweeps are delayed, measurement results are never disturbed.

If the Independent Source is enabled for your measurement, it will be borrowed to perform the alignment. Again, the measurement results are not disturbed. Learn about the Independent Source in [“Independent Source/Tracking Generator” on page 181](#).

The alignment process can be disabled. You may want to do this, for example, if you are analyzing the amplitude stability of a signal.

## How to make Burst Alignment settings

These settings do NOT survive a Preset or Mode Preset.

- Press **Cal 5**
- Then **Individual Align**

- Then **Burst Alignment**
- Then choose from the following:
  - **Auto** (Default setting) SA measurement applications monitor changes in internal temperature and the time since last alignment update and trigger the need for a new update when the alignment becomes stale. The alignment is deemed stale after a significant change in temperature or a significant time elapsed from the last update. The temperature change and time duration necessary to trigger an alignment update is predetermined in the factory.
  - **OFF** The alignment process is NOT performed. Only factory correction values are used.
  - **Hold** The alignment process is stopped, but the last alignment values are applied to subsequent sweeps.

**Burst Align Now** An alignment is performed once and applied to subsequent sweeps.

### Channel Equalization (IQA and RTSA Only)

#### NOTE

During continuous sweep operation for RTSA and continuous acquisition for IQA, automatic Alignments will NOT interrupt the ongoing measurement, but when necessary, will occur opportunistically as settings are changed. When no automatic alignment updates occur, existing alignments can become stale over time and temperature drift, so a warning annotation on the left panel will light up indicating that alignments need updating. When alignments need updating, you will see a “Channel Equalization” or “ChanEq” error message displayed.

---

IQA and RTSA modes use proprietary channel equalization algorithms to make extremely accurate channel measurements over the full frequency range of the FieldFox.

### How to make Channel Equalization Alignments settings

These settings do NOT survive a Preset or Mode Preset.

- Press **Cal 5**
- Then **Individual Align**
- Then **ChanEq Alignment**
- Then choose from the following:
  - **Auto** (Default setting) SA measurement applications monitor changes in internal temperature and the time since last alignment update and trigger the need for a new update when the alignment becomes stale. The alignment is deemed stale after a significant

change in temperature or a significant time elapsed from the last update. The temperature change and time duration necessary to trigger an alignment update is predetermined in the factory.

Some examples of the conditions when alignments occur are: This could be a Center frequency change, or it could be as simple as requesting a Single sweep. Also, unique alignments are required at different FieldFox receiver frequency bands, so even if the temperature hasn't changed, an alignment may be required when one changes the Center frequency.

- **Hold** The alignment process is stopped, but the last alignment values are applied to subsequent sweeps.
- **OFF** The alignment process is NOT performed, and the channel equalization is deactivated.
- **ChanEq Align Now** An alignment is performed immediately.

The **Amptd?** annotation lights up whenever the current channel equalization is deemed stale.

## Detection Method

In SA Mode, the X-axis is comprised of data points, also known as “buckets”. The number of data points is specified using the Points setting. Learn more in **“Points ” on page 198**.

Regardless of how many data points are across the X-axis, each data point must represent what has occurred over some frequency range and time interval.

From the frequency span of the measurement, the span of each data point is calculated as  $(\text{frequency span} / (\text{data points} - 1))$ . The detection method allows you to choose how the measurements in each bucket are displayed.

Figure 9-14 Detection using One Bucket

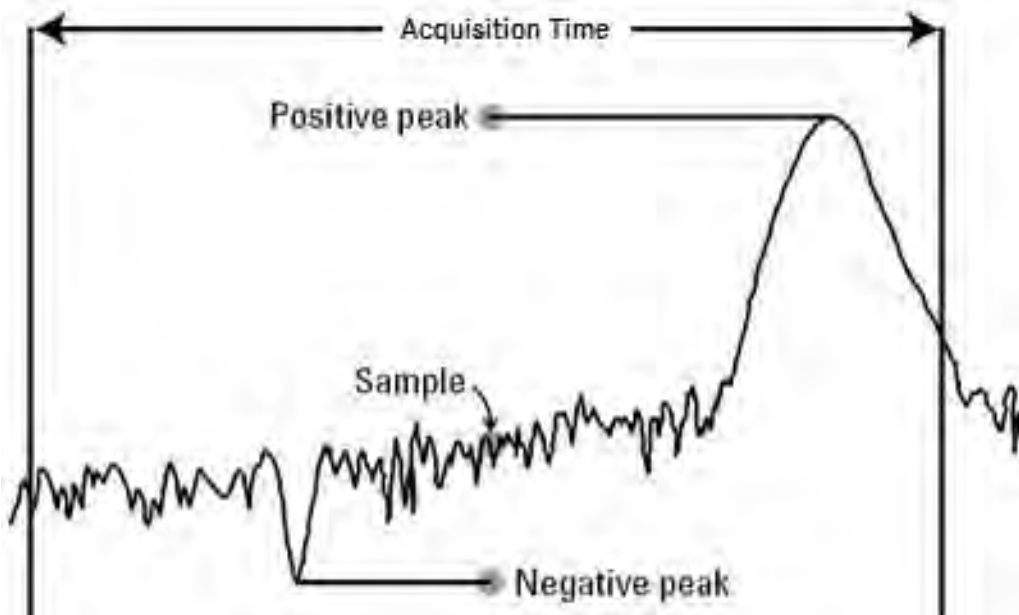

In the graphic above there is one bucket showing Positive peak, Sample, and Negative peak Detection methods.

### How to set Detection Method

The current Detection method is labeled on the left edge of the screen. When a method is selected manually, a # precedes the label. For example: **# Nrm** means that **Normal** was selected from the softkeys.

- Press **Trace 6** > **Detector**
- Then choose from the following:
  - **Auto** Displays the most appropriate Detection method based on other settings. [**# is NOT shown**]
  - **Normal** [**#Nrm**] Provides a better visual display of random noise than **Positive peak** and avoids the missed-signal problem of the **Sample** Mode. Should the signal both rise and fall within the bucket interval, then the algorithm classifies the signal as noise. An odd-numbered data point displays the maximum value encountered during its bucket. An even-numbered data point displays the minimum value encountered during its bucket. If the signal is NOT classified as noise (does NOT rise and fall) then Normal is equivalent to Positive Peak.
  - **Positive Peak** [**#Pk**] Displays the maximum value of all the measurements in each bucket. This setting ensures that no signal is missed. However, it is not a good representation of the random noise in each bucket.
  - **Negative Peak** [**#NPK**] Displays the minimum value of all the measurements in each bucket.

- **Sample** [#Smp] Displays the center measurement of all the measurements in each bucket. This setting gives a good representation of the random noise in each bucket. However, it does not ensure that all signals are represented.
- **Average** [#RMS] Displays the Root Mean Squared (RMS) average power of all the measurements in each bucket. This is the preferred method when making power measurements.

## Display Line

A display line is a simple, horizontal line that can be placed at any amplitude level on the SA screen or set to any level in IQA. Use a display line as mental guide for visual feedback. A display line is similar to a Limit Line, except that no PASS/FAIL testing occurs. A display line is easier to create than a Limit Line. Learn more in **“All about Limit Lines” on page 715**.

Figure 9-15 Display Line with Annotations

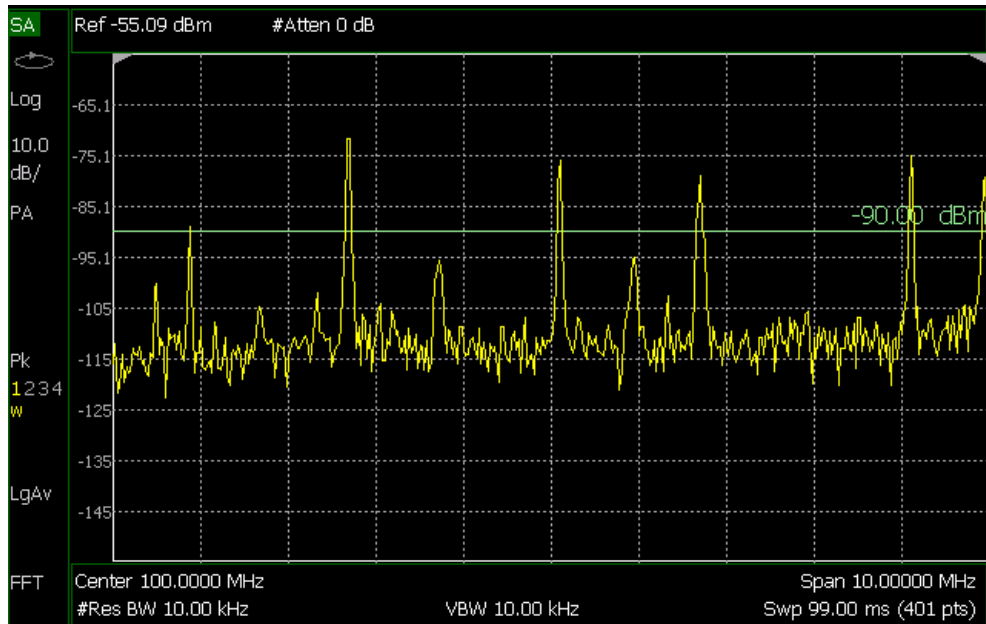

### How to create and move a Display Line

- Press **Limit 8**
- Then **Display Line OFF ON**
- Then enter a Y-axis value using the **▲▼** arrows or the rotary knob, then press **Enter**. Or enter a value using the numeric keypad and press a suffix key or press **Enter**.

Learn more, **“All about Limit Lines” on page 715**.

## Noise Marker

For comparison purposes, electronic noise measurements are often displayed as though the measurement was made in a 1 Hz Res BW. However, making an actual measurement at a 1 Hz Res BW is extremely slow.

A Noise Marker, unique to SA Mode, mathematically calculates the noise measurement as though it were made using a 1 Hz bandwidth.

Several data points (or ‘buckets’) are averaged together to calculate the Noise Marker readout. To accurately measure noise, the Noise Marker should NOT be placed on, or too close to, a signal. The distance from a signal depends on several factors. To know if an accurate reading is being made, move the Noise Marker until consistent measurements are displayed in adjacent data points.

In addition, when a Noise Marker is displayed, the Detection method is automatically switched to Average and **PAvg** is shown on the FieldFox screen. This occurs only when Detector is set to Auto. Learn more in [“Detection Method” on page 208](#).

With a Noise Marker present, the Res BW can be changed and the displayed noise floor will also change, but the Noise Marker readout will remain about the same.

Noise Markers can be used like regular markers. A Noise Marker is distinguished from a regular marker by **(1Hz)** after the marker readout value. Learn more about regular markers in [“All about Markers” on page 700](#).

### How to measure Noise with a marker

- Press **Marker** to create or select a Normal or Delta marker to use to measure Noise.
- Then **More**.
- Then **Marker Function**.
- Then **Noise ON OFF**.

## Band/Interval Power Marker

A Band/Interval Power marker—available in IQA and SA Modes—accumulates the power that is measured over several adjacent data points (or ‘buckets’). The range of buckets being measured is displayed with vertical posts around the marker. This Band Span value is selectable.

This feature is very similar to a channel power measurement ([“Channel Power \(CHP\)” on page 216](#)).

When the frequency span is set to Zero span, the marker is referred to as an Interval Band Marker because it averages power over a specific time interval. In this case the range is specified as the Interval Span. Learn more about Zero span measurements in [“Zero Span Measurements” on page 190](#).

If the Detection method and Averaging type are set to Auto when you enable a Band/Interval Power marker, the Detection method will change to Average (RMS) and Averaging type will change to Power average. Other Detection methods or Averaging type settings will usually cause measurement inaccuracy. Learn more about Detection method in [“Detection Method” on page 208](#), and Averaging Type in [“Average Type” on page 199](#).

Summary:

- In Zero span, an Interval Power Marker yields the average power over the specified time interval.
- In non-Zero span, a Band Power Marker yields the total power over the specified frequency range.

### How to measure Band/Interval Power with a marker

- Press **Marker** to create or select a Normal or Delta marker to use to measure Band/Interval Power.
- Then press **More**
- Then **Marker Function**
- Then **Band/Int Power**
- Then **Band (or Interval) Span**
- Then choose from the following:
  - **Auto** Measures power over 5% of the displayed span, or ½ graticules. The Band Span is automatically updated to remain at 5% when you change the frequency span.
  - **Man** Enter a frequency or time value using the **▲▼** arrows or the rotary knob, then press **Enter**. Or enter a value using the numeric keypad and select a frequency or time suffix. The Band Span remains at the frequency or time value that you set as the span changes.

### Frequency Counter at Marker

- **Available in SA Mode ONLY.** Use any existing marker to make highly-accurate frequency counter readings. For highest accuracy, lock the FieldFox to a stable external frequency reference. Learn how in [“Frequency Reference Source” on page 760](#).

When Frequency Counter is ON, the FieldFox uses background sweeps to zoom on the signal, measure the signal peak with 1 Hz resolution, and display the frequency of the signal peak in the marker annotation area. The marker does not move to the signal peak.

When Freq Counter is ON, measurement sweeps are considerably slower.

## How to use Frequency Counter

- Press **Marker**.
- Press Normal, Delta, or Peak, or select an existing marker to use as a frequency counter.
- Locate the marker somewhere on a CW signal. It does NOT have to be on the peak.
- Then **More**
- Then **Freq Count ON**
- With Freq Count ON, you can scroll through the existing markers that are located on a discrete CW signal, and read the frequency of the signal peak. However, each frequency count update requires another sweep. If the FieldFox is in HOLD, press **Single** to update the frequency count results.

## Time Zero Fixed Marker

This feature was created to allow recall of vintage instrument states (older than Rev. 7.0) that included Zero span sweep with a trigger delay and at least one marker. Before Rev. 7.0, these instrument states were saved and recalled with the equivalent of the ON state of this setting. The default setting is OFF. Learn more about Triggering with negative delay in **“Triggering” on page 192**.

- Press **Mkr->/Tools**
- Then **More**
- Then **Mkr Properties**
- Then **Time Zero Fixed**
- Then choose from the following:
  - **ON** Time Zero is fixed at the left-edge of the screen. A marker in negative delay resides at this point. This is the vintage behavior.
  - **OFF** (default) Time Zero is located at the T-zero indicators. A marker in negative delay appears to the left of T-zero.

## Audio Beep at Marker Power

When enabled, the Audio Beep feature emits a repetitive beep sound which varies in tone pitch and repetition rate to indicate the relative power level of the active marker. The highest tone pitch and fastest beep rate occurs when the marker Y-axis position is at the top of the display. Conversely, the lowest pitch and repetition rate occurs at the bottom of the display. Therefore, it is important to scale the signals that you intend to measure between the top and bottom of the screen. Learn more about Scale in **“Scale and Units” on page 157**.

Audio Beep can be used with any marker type or function, including Band/Interval Power. Learn more in [“Audio” on page 745](#).

### How to use Audio Beep

- Press **Marker**
- Optionally, press **Marker 1 2 3 4 5 6** to select an existing marker to use with Audio Beep. A marker will be created if one does not already exist.
- Then **More**
- Then **Marker Function**
- Then **Audio Beep ON OFF**

Audio Beep does NOT beep when the FieldFox is in Hold mode.

While Audio Beep is ON, press **Marker 1 2 3 4 5 6** to toggle Audio Beep through the existing markers.

To set FieldFox speaker volume control, press **System**, then **Volume**. Learn more in [“Audio” on page 745](#).

### Meas UNCAL Error

**Meas UNCAL** appears in the lower-left corner of the screen when the FieldFox can NOT display accurate measurement results with the current settings. Usually, the part of the trace that is inaccurate is shown at –200 dB.

The following situation can produce **Meas UNCAL**:

- When the ResBW/VBW ratio exceeds 10,000, causing the VBW filter to reach the maximum capacity for averaging.

### Old Data Indicator (\*)

In SA mode, when the current trace does not exactly match the annotation that is on the screen, an asterisk is displayed in the upper-right corner of the screen graticule area. This would occur, for example, when the Res BW setting is changed while in sweep Hold mode. The annotation is changed immediately, but the trace is not updated until the next sweep occurs. Therefore, the current data trace does not match the screen annotation. See the asterisk in [Figure 9-1 on page 147](#).

## Channel Measurements

The following Channel Measurements are offered in SA Mode:

- Channel Power [“Channel Power \(CHP\)” on page 216](#)
- Occupied Bandwidth [“Occupied Bandwidth” on page 218](#)
- Adjacent Channel Power Ratio [“Adjacent Channel Power Ratio \(ACPR\)” on page 220](#)

## Radio Standards and Channel Measurements

To tune the frequency range of any of the Channel Measurements using channels instead of frequency, first select a Radio Standard, then select Units = CHAN. Learn how to select a Radio Standard and channels in [“How to select a Radio Standard” on page 154](#).

When you first select a Radio Standard, then select a Channel Measurement:

- With Units = FREQ selected, the center frequency and span will ALWAYS change to the full frequency range of that standard (Uplink and Downlink) to allow for a quick scan of energy. The X-axis annotation indicates the frequency range.
- With Units = CHAN selected, the FieldFox chooses either the uplink or downlink band, and displays that range of frequencies. You can then tune within that Standard using Start CHAN, Stop CHAN, or Center CHAN. The X-axis annotation indicates the frequency range.

When you **first select a Channel Measurement**, then select a **Radio Standard**, the BW, Offset, RRC, Integration BW, and Span settings are changed to those of the standard. In addition, Res BW can also change when set to ‘Auto(couple)’. However, center frequency is NOT changed unless you first select Units = CHAN.

## Measurement Preset

Measurement Preset allows you to easily reset any of the channel measurements to its default settings. The Center Frequency, Preamp ON|OFF, RF Attenuation, Markers, Limits, and Radio Standard settings are NOT reset.

### How to select Measurement Preset:

- Press **Preset** then **Mode Preset**

## Averaging

By default in ALL Channel measurements, averaging is enabled and set to display the average of the last 15 measurements. When enabled, this average setting is automatically making the following ‘averaging’ settings in order to provide the most accurate power measurements:

## SA (Spectrum Analyzer) Mode (Option 233–Mixed Analyzers) Channel Measurements

- Averaging Type is set to Power.
- Trace State is set to Average.
- Detector is set to Average.
- Count is set to 15.

Any of these settings can be changed manually during a Channel measurement. Learn more about these settings starting in **“Average Type” on page 199**.

To change Averaging:

- Press **Meas Setup 4**.
- Then **Average Enable ON OFF** OFF effectively sets the Average Count to 1.
- Then **Average Count**
- Enter a value between 1 and 10,000 using the numeric keypad, **▲▼** arrows, or the rotary knob.
- Press **Enter**.

## Traces

Only one measurement trace can be displayed in Channel Measurements.

## Channel Power (CHP)

Channel Power measures total power over the specified Integrated BW. The Integration Bandwidth (IBW) can be adjusted to measure the power over multiple channels.

Figure 9-16 Channel Power Measurement

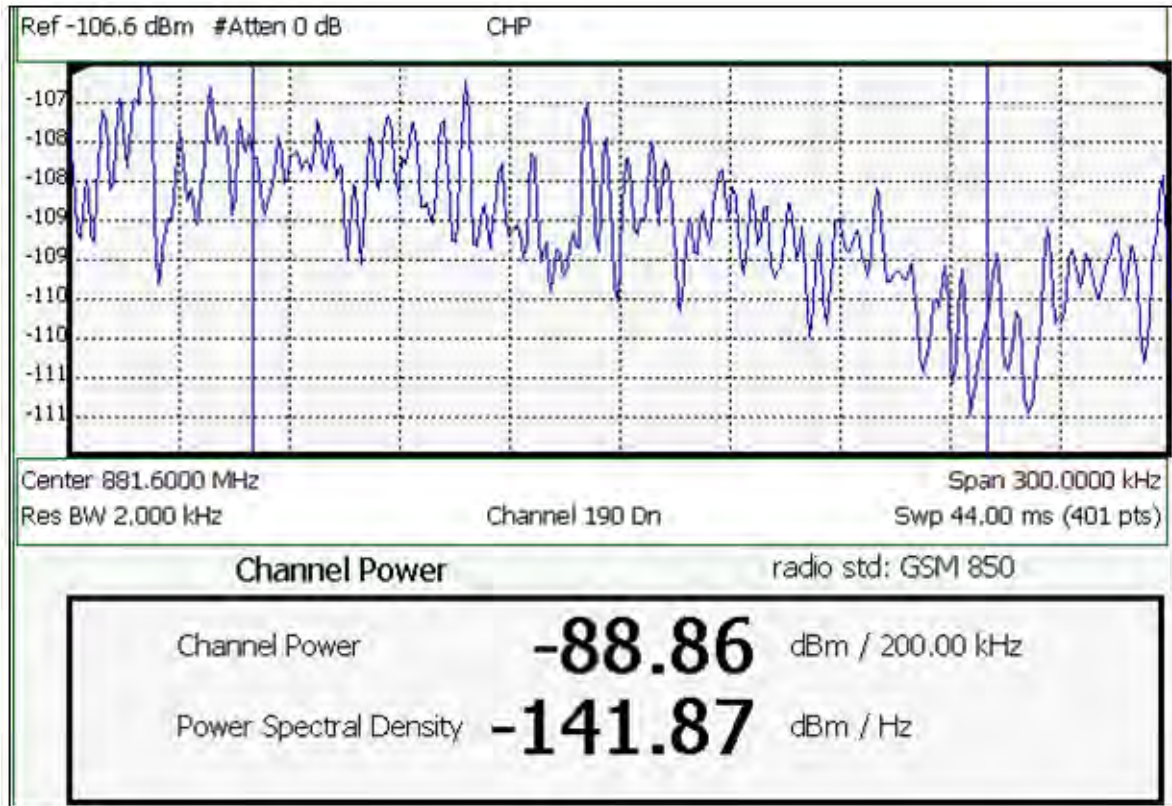

The following two Channel Power levels are displayed:

- **Channel Power** - measures total power over the specified Integrated BW.
- **Power Spectral Density** – same measured power, but mathematically normalized to a 1 Hz bandwidth using the same algorithm as Noise Marker. Learn more about the Noise Marker in [“Noise Marker” on page 211](#).

#### How to select Channel Power

- Press **Measure 1**
- Then **Channel Measurements**
- Then **Channel Power**

When Channel Power is selected, the following settings are maintained from a previous measurement: Center Frequency, Preamp ON|OFF, and RF Attenuation.

#### Integration Bandwidth

When Channel Power is selected, vertical posts appear on the display to mark the current Integration Bandwidth setting. The displayed Channel Power and Power Spectral Density values are measured and calculated over the specified Integration Bandwidth.

By default, the displayed frequency span is automatically coupled to the Integration Bandwidth. As you change the Integration Bandwidth, the frequency span is adjusted so that the vertical posts appear to NOT move. However, when you manually change the frequency span, the Integration Bandwidth is no longer coupled to the frequency span.

When a Radio Standard is selected, the appropriate Integration Bandwidth is set automatically. Learn more about Radio Standards in [“Radio Standard” on page 153](#).

To change Integration Bandwidth:

- Press **Meas Setup 4**
- Then **Integ BW** (Integrating Bandwidth)
- Enter a value between 100 Hz and 5 GHz using the numeric keypad,  arrows, or the rotary knob.
- Press **Enter**

### Other Channel Power Settings

All relevant FieldFox settings are made automatically to ensure the highest accuracy, such as ResBW, VideoBW, and sweep (SwpAcquisition) speed. These, and all other SA Mode settings, can be changed manually in a Channel Power measurement.

- Learn about Measurement Preset in [“Measurement Preset” on page 215](#).
- Learn about Averaging in [“Averaging” on page 215](#).
- Learn about RRC Weighting in [“RRC Weighting” on page 224](#).

### Occupied Bandwidth

Occupied Bandwidth measures the power of the displayed frequency span and displays vertical posts at the frequencies between which the specified percentage of the power is contained. The frequency span between the two vertical posts is the Occupied Bandwidth. The Occupied Power, the power that is contained between the two posts, is also displayed in dBm.

Figure 9-17 Occupied Bandwidth Measurement

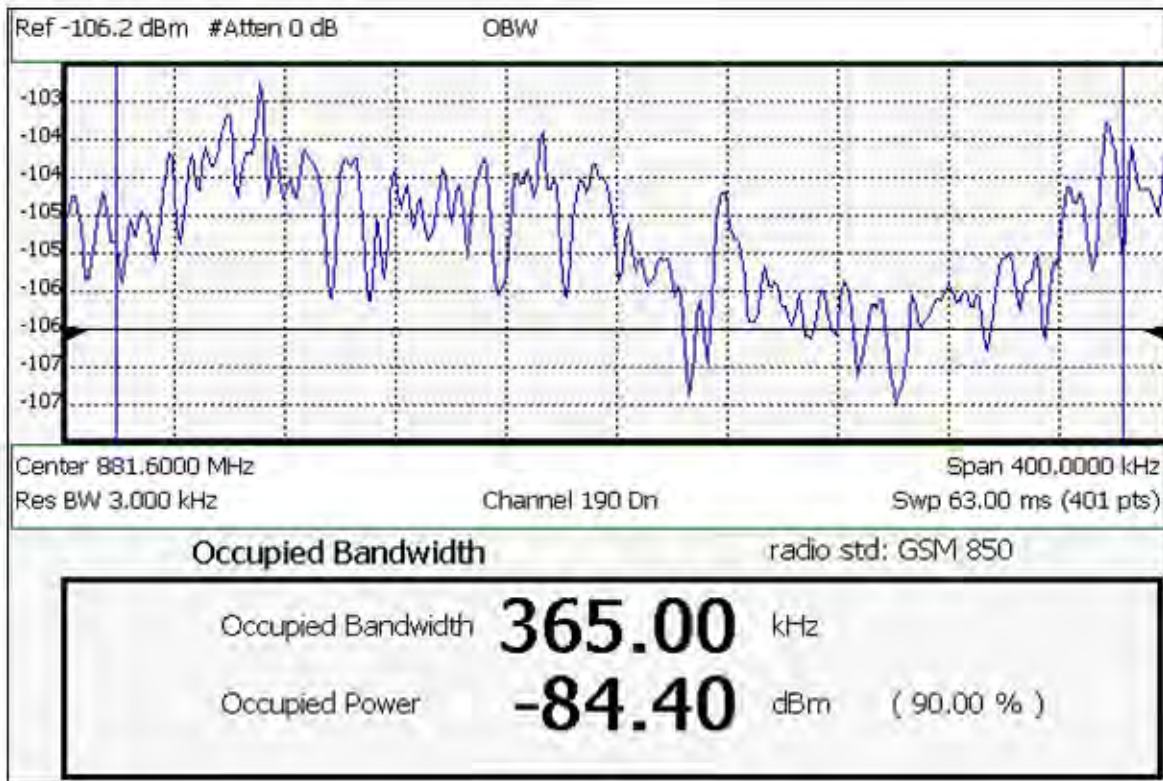

The graphic above shows an OBW measurement; Chan 190 Downlink; GSM850 Radio Standard

### How to Select Occupied Bandwidth

- Press **Measure 1**
- Then **Channel Measurements**
- Then **Occupied BW**

When Occupied Bandwidth is selected, the following settings are maintained from a previous measurement: Center Frequency, Preamp ON|OFF, and RF Attenuation.

### Frequency Span

Occupied BW is calculated from power that is measured over the entire displayed Frequency Span. The frequency span can be entered using arbitrary frequencies or by using a Radio Standard in conjunction with channel numbers. Learn how to select a Radio Standard and channels in **“Channel Selection” on page 155**.

To change Frequency Span:

- Press **Freq/Dist**

- Then **Freq Span**

**NOTE**

Integration BW (IBW) is coupled to the Frequency Span setting. Frequency Span is 50% wider than the IBW (e.g., if the IBW value is 1 MHz, then the Frequency Span value is 1.5 MHz).

---

- Enter a value using the numeric keypad, **▲▼** arrows, or the rotary knob.
- Press **Enter**

### Power Percent

This setting specifies the percentage of total measured power to display between the vertical posts. The measurement defaults to 99% of the occupied bandwidth power. The remaining power (1% of default setting) is evenly distributed; .5% of the power on the outside of each side of the vertical posts.

To change Power Percent:

- Press **Meas Setup 4**
- Then **Power Percent**
- Enter a value between 10 and 99.99 using the numeric keypad, **▲▼** arrows, or the rotary knob.
- Press **Enter**.

### Other Occupied Bandwidth Settings

All relevant FieldFox settings are made automatically to ensure the highest accuracy, such as ResBW, VideoBW, and sweep (SwpAcquisition) speed. These, and all other SA Mode settings, can be changed manually in a Occupied Bandwidth measurement.

- Learn about Measurement Preset in [“Measurement Preset” on page 215](#).
- Learn about Averaging in [“Averaging” on page 215](#).

### Adjacent Channel Power Ratio (ACPR)

ACPR measures the power of a carrier channel and the power in its adjacent (offset) channels. The measurement results can help you determine whether the carrier power is set correctly and whether the transmitter filter is working properly.

You can measure the channel power in one, two, or three adjacent (offset) channels on the low frequency and high frequency side of the carrier channel.

Limits can be used to quickly see if too much power is measured in the adjacent channels.

Figure 9-18 GSM 850-Ch 251-Up with one Offset

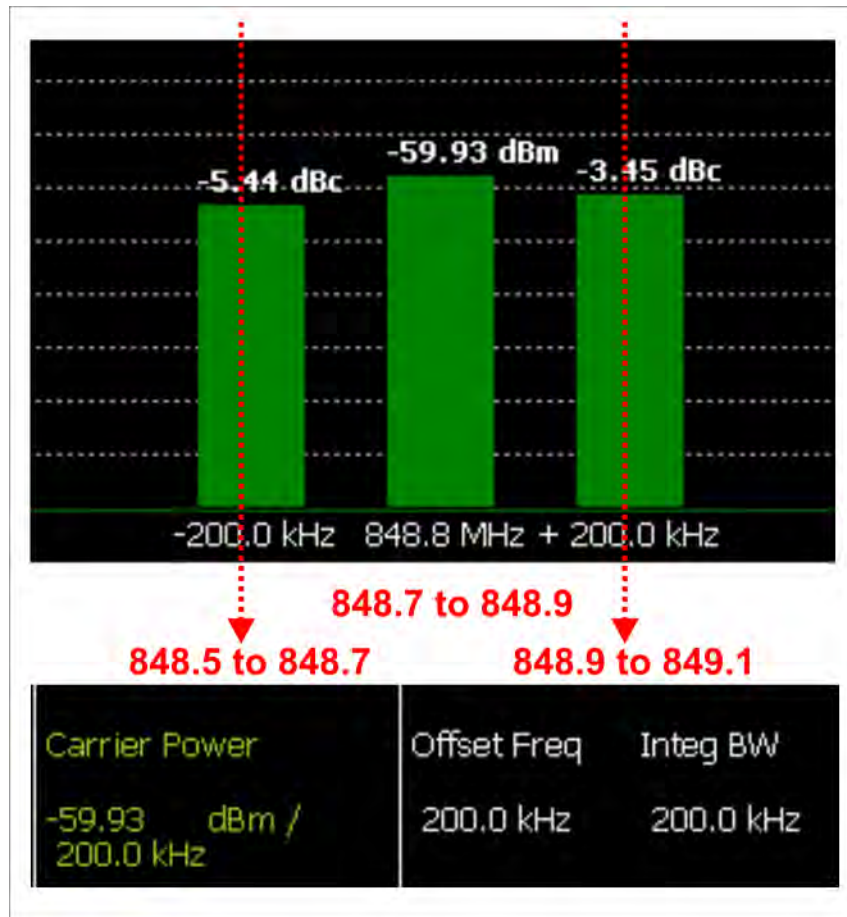

In the graphic above, red frequencies (MHz) are added to illustrate offset and integ BW.

Data in the ACPR graphical chart is always presented in dBm for the carrier, and dBc (dB below the carrier) for the offsets. This can NOT be changed. Use the **Meas Type** setting (next page) to change how the data is presented in the table below the graph.

#### How to select ACPR

- Press **Measure 1**
- Then **Channel Measurements**
- Then **Adjacent Channel Power**

When ACPR is selected, the following settings are maintained from a previous measurement: Center Frequency, Preamp ON|OFF, and RF Attenuation.

## Frequency Range/Channel

When a Radio Standard is selected, the appropriate center frequency or channel and span is set automatically. The frequency or channel number can then be changed from the **Freq/Dist** menu. Learn how to select a Radio Standard and channels in **“Radio Standard” on page 153**.

The frequency range of an ACPR measurement can also be entered using arbitrary frequencies.

When a Radio Standard is NOT selected, the center frequency of a previous measurement is maintained when ACPR is selected.

## Integration Bandwidth

The Integration Bandwidth of the carrier and offsets is the frequency span over which power is measured.

To change Integration Bandwidth:

- Press **Meas Setup 4**
- Then **Integrating BW**
- Enter a value between 100 Hz and 100 MHz using the numeric keypad, **▲▼** arrows, or the rotary knob.
- Press **Enter**

## How to define adjacent (Offset) channels

An offset represents a difference in center frequencies of the carrier channel and its adjacent channel to be measured. The frequency range for each offset is specified with an Offset Freq and Integ BW. Each offset that is created has a Lower (carrier MINUS Offset Freq) and Upper (carrier PLUS Offset Freq) set of frequencies.

- Press **Meas Setup 4**
- Then **Offsets**
- Press **Offset 1 2 3** to select an offset.
- Then **Offset State** to set that offset ON or OFF.
- Select **Offset Freq** This is the difference between the **carrier center frequency** and the **center frequency of the offset channel**. Then enter a value using the numeric keypad.
- Select **Offset Integ BW** This is the frequency range over which power is measured in that offset; half of the range below and half above the Offset Freq.

## How to set limits for adjacent channels

You can set a unique threshold power for each of the offsets that will cause a FAIL indication (RED bar). This occurs when the calculated **dBc** power (on top of the offset bar) is ABOVE the specified level.

To set limits, with an ACPR measurement on the screen:

- Press **Limit 8**
- Then **Offset (1,2,3)**
- Then choose from the following:
  - **LowerOffsetLimit** Sets a limit for the lower-frequency offset.
  - **Upper OffsetLimit** Sets a limit for the higher-frequency offset.
- Then enter a value using the numeric keypad, **▲▼** arrows, or the rotary knob.
- Then **Limit Test ON OFF**

## Measurement Type

This setting determines how the measured carrier and offset power levels in the **table** are presented. (Data in the graphical chart is always presented in dBm for the carrier and dBc for the offsets.)

To select Meas Type:

- Press **Meas Setup 4**.
- Then **More**
- Then **Meas Type**
- Then choose from the following:
  - **Total Pwr Ref** – Integrated carrier power is represented in dBm, and relative powers between offsets and carrier are represented as dBc (dB below the carrier).
  - **PSD Ref (Power Spectral Density)** – Integrated carrier power is normalized to a 1 Hz density as dBm/Hz using a similar algorithm as Noise Marker. Learn more about the Noise Marker in **“Noise Marker” on page 211**.

For both Meas Types, choose the reference for the offset data.

- Press **Ref Value** to toggle between these settings:
  - **Auto** – dB or dBc value is computed by subtracting the measured carrier power from the measured offset power.
  - **Man** – dB or dBc value is computed by subtracting the entered RefValue from the measured offset power.

- Then enter a value to be used to reference the data using the numeric keypad,  arrows, or the rotary knob.

### Other ACPR Settings

All relevant FieldFox settings are made automatically to ensure the highest accuracy, such as ResBW, VideoBW, and sweep (SwpAcquisition) speed. These, and all other SA Mode settings, can be changed manually in a ACPR measurement.

- Learn about Measurement Preset in [“Measurement Preset” on page 215](#).
- Learn about Averaging in [“Averaging” on page 215](#).

### RRC Weighting

RRC, or Root-Raised-Cosign weighting, is offered with Channel Power and ACPR measurements.

When RRC Weighting is applied to transmitted and received power, the edges of the channel are ‘smoothed’ to help prevent interference. To accurately measure a channel that has RRC weighting, set the same value of RRC weighting as that used in the transmitter and receiver.

Figure 9-19 Channel power measurement with .22 RRC applied

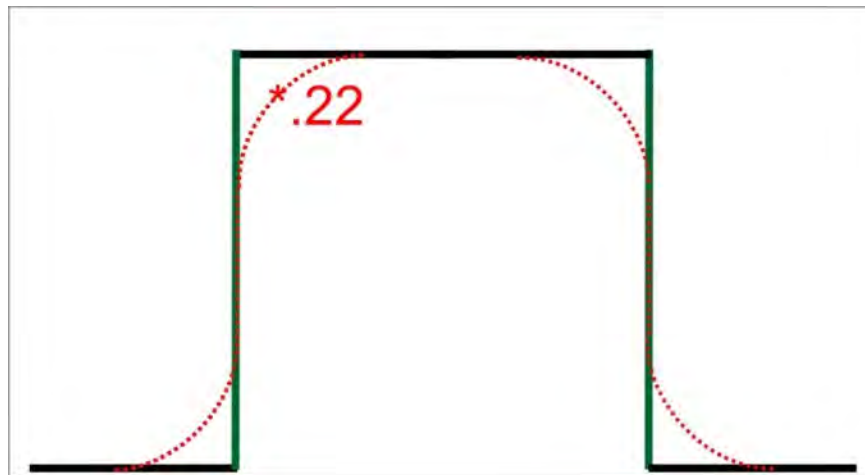

RRC Weighting is set and enabled automatically when included in a selected radio standard.

To set and enable RRC Weighting:

- Press **Meas Setup 4**
- Then **RRC Weighting ON OFF**
- Then **More**
- Then **RRC Alpha [current setting]**

SA (Spectrum Analyzer) Mode (Option 233–Mixed Analyzers)  
Channel Measurements

- Enter a value between 0 (no smoothing) and 1 (most smoothing) using the numeric keypad,  arrows, or the rotary knob. A standard level of filtering is 22.
- Press **Enter**.

## How to Set Up EMF Settings (Requires EMF (Option 358), GPS (Option 307), and SA Mode (Option 233–Mixed Analyzers))

### CAUTION

If OTA or SA mode does not detect an EMF Option 358 license, then the EMF application and the USB antenna's axes must be set up manually. This use model is not recommended or supported by Keysight.

---

### CAUTION

The USB antenna's cable loss is **not** included, in the antenna's correction factors. For an accurate EMF measurement, the cable loss values should be accounted for. Refer to **“Editing Cable Correction Factors and Adding New Cable Factors” on page 235.**

---

### NOTE

**IMPORTANT!** The USB triaxial antenna—or equivalent—is required for EMF measurements. Refer to **Chapter 15, “USB Antennas – (Full Capability Requires EMF Option 358, and either SA mode (Option 233 Mixed Analyzers) or OTA–5G NR / 5G NR EVM Conducted Option 378).”**

---

EMF mode measures signals at the SA RF Input Port 2 connector.

EMF mode requires the FieldFox to have SA mode (Option 233 on combination analyzers), or 5G NR Option 378), GPS (Option 307), and CPU2 installed.

Recommended, but not required, preamplifier (Option 235) to improve receiver sensitivity.

With Option 358 (EMF), network designers can measure and verify the RF exposure compliance as required by each country.

If SA mode is licensed for EMF Option 358, the primary measurement performed is Channel Power (CHP) which automatically switches amongst the 3 TriAxial antenna axis (X/Y/Z), to provide a summation of “total power” detected, using unique Antenna supplied corrections for the individual axis, with results in FieldStrength units. This is accomplished within the existing SA Channel Power measurement.

Even without license EMF Option 358, the System Utilities menu enables one to Import Corrections and manually drive the Antenna to a particular axis (X, Y, or Z). The manual control thus allows any SA Receiver measurement to sweep that axis just like any other antenna transducer, however without license the imported corrections are not usable from the Apps. But with license the SA provides for easy use of the imported XYZ corrections, thus allowing presentation of correctly compensated FieldStrength measurements, for 1 axis at a time.

This section reviews the steps in setting up an EMF measurement, using a USB antenna. If you are not familiar with this process or would like more information, refer to **Chapter 15, “USB Antennas – (Full Capability Requires EMF Option 358, and either SA mode (Option 233 Mixed Analyzers) or OTA–5G NR / 5G NR EVM Conducted Option 378).”**

This section consists of:

SA (Spectrum Analyzer) Mode (Option 233–Mixed Analyzers)  
How to Set Up EMF Settings (Requires EMF (Option 358), GPS (Option 307), and SA Mode (Option 233–Mixed Analyzers))

- “EMF Features” on page 227
- EMF Setup Procedure

## EMF Features

### EMF has the following features:

EMF Measurement Results:

- Measure and display corrected field strength in RMS average power
- Antenna control over X, Y, and Z antenna factors downloaded via USB
- Pass/Fail limit testing supported
- External PC **not** required

EMF uses the following data formats:

- Field Strength units:
  - dB $\mu$ V/m – For use with E-field signals
  - dB $\mu$ A/m – For use with H-field signals
  - dBG – dB Gauss
  - dBpT – dB Tesla

SA (Spectrum Analyzer) Mode (Option 233–Mixed Analyzers)  
 How to Set Up EMF Settings (Requires EMF (Option 358), GPS (Option 307), and SA Mode (Option 233–Mixed Analyzers))

Figure 9-20 Example of EMF with Triaxial Antenna

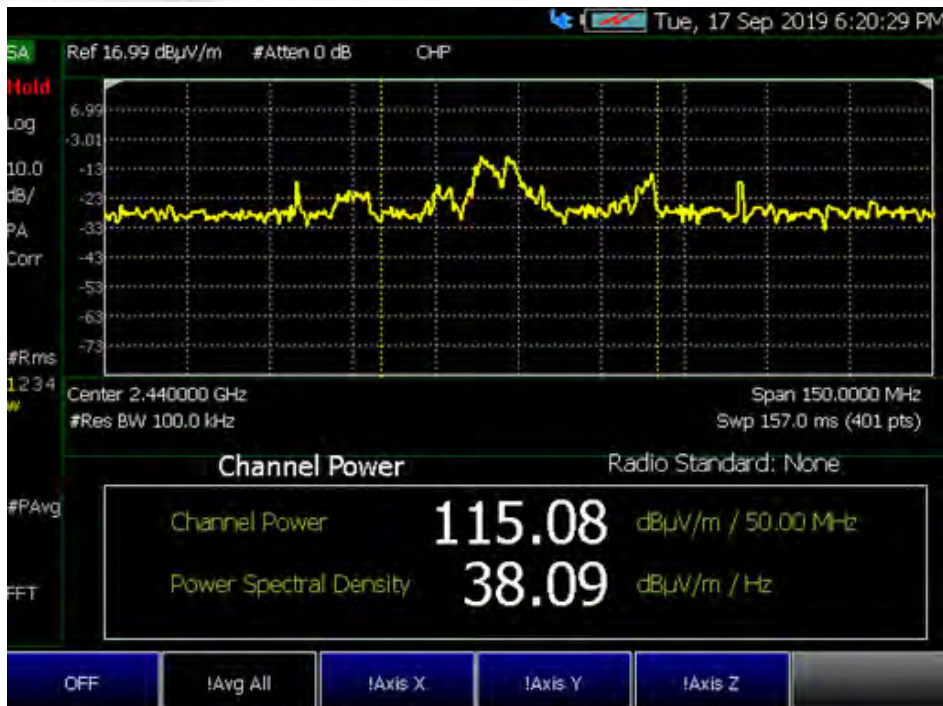
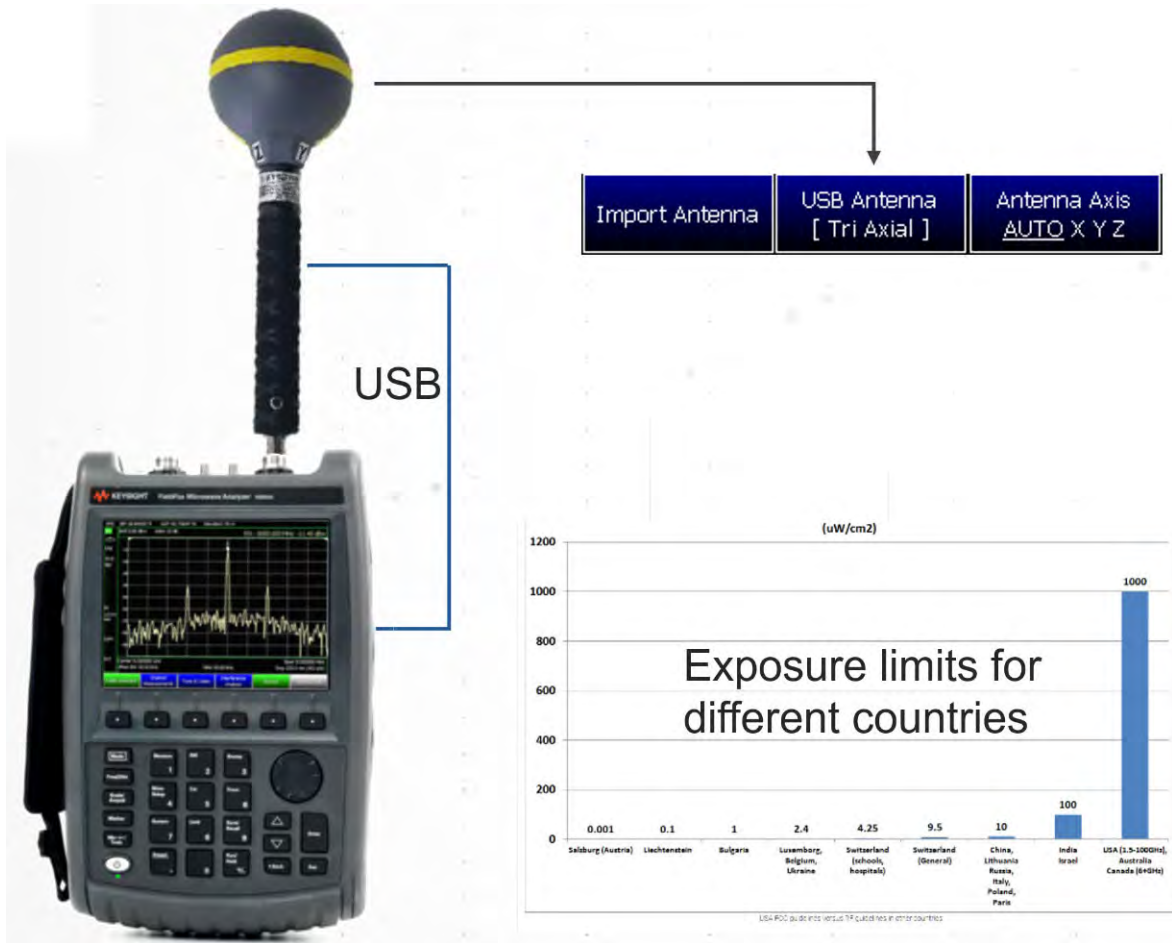

## EMF Setup Procedure

### NOTE

When the USB antenna correction factors are imported, EMF (Option 358) couples many settings to ease setting up the EMF measurement (e.g., **Apply Corrections** is enabled, all X, Y, and Z antenna axes are enabled, and **Amp Corr Select** is set to **TriAxial XYZ**).

### 1. Setup the FieldFox Spectrum Analyzer for a Channel Power measurement.

a. Press **Mode** > **SA** >

Press **Measure 1** > **Channel Measurements** > **Channel Power**

See also, “**Channel Measurements**” on page 215.

### NOTE

If necessary, this step can be skipped and done after the USB antenna is set up.

### 2. Connect a USB antenna’s RF cable to the **SA RF Input**, port 2 and the USB connector to a FieldFox USB port. See also, **Figure 9-20 on page 228** and to **Chapter 15, “USB Antennas – (Full Capability Requires EMF Option 358, and either SA mode (Option 233 Mixed Analyzers) or OTA–5G NR / 5G NR EVM Conducted Option 378).”**

### CAUTION

Only Agos Advanced Technologies SDIA–6000 Triaxial Isotropic USB antenna is currently compatible with EMF (Option 358).

### 3. Importing and selecting the X/Y/Z antenna factors:

a. Press **System** > **Utilities** > **USB Antennas**

– Then **Import Antenna** – to import the antenna factors from the antenna’s memory over the USB connection (this may take 5 seconds or so and vary with the Triaxial antenna).

### NOTE

If the antenna factor import is successful, the FieldFox displays: “Success: Antenna Factors Imported: Tri-Ax Antenna ID: ->[R] Antenna ID: SDIA-6000-1006 ->[ ]”. The last 4-digits will vary for each antenna (i.e., “1006” value will vary).

If the FieldFox displays this error **Error: USB antenna Error: Not found or Unable to communicate with antenna. Ensure it is connected.** is displayed, verify the USB antenna is connected correctly. See also, “**Troubleshooting**” on page 456.

– Then **USB Antenna [Tri Axial]** verify Triaxial (default) is selected.

– Optional: Press **Antenna Axis** the antenna axis should be set to **Auto** for default operation. When AUTO is selected the application (e.g., Channel Power or OTA) controls the axes and switches as needed. With the AUTO setting, all antenna elements (X, Y, and Z) are OFF.

SA (Spectrum Analyzer) Mode (Option 233–Mixed Analyzers)  
 How to Set Up EMF Settings (Requires EMF (Option 358), GPS (Option 307), and SA Mode (Option 233–Mixed Analyzers))

- Press **Back** > **Back** to exit the USB Antenna softkey menu.

4. Modifying the EMF settings:

Press **Meas Setup 4**

- Then **More** > **EMF** then
  - **EMF Meas OFF ON** disable/enable the EMF measurement.
  - **EMF Units** choose dBuV/m (default) or V/m.
  - **Back** to exit to the previous softkey menu.

For more details on editing the USB antenna, refer to **Chapter 15, “USB Antennas – (Full Capability Requires EMF Option 358, and either SA mode (Option 233 Mixed Analyzers) or OTA–5G NR / 5G NR EVM Conducted Option 378).”**

5. Enabling the imported USB antenna factors and Cable factors:

- Enabling the Channel Power: Press **Measure 1** > **Channel Measurements** > **Channel Power**
- To enable the Triaxial antenna for EMF: Press **Scale/Amptd** > **Amp Corr Select [Default]** > **TriAxial XYZ**

With Sum all, the field strength from all three axes is summed and displayed. The RF measurements are switched between the three different antennas (three dipoles), and the resulting summation of the total power collected, and averaged.

Alternatively, you can select either of three axes to individually measure the field strength in the one direction.

- Else, if the **SysCtrl Triaxial** softkey is viewable (i.e., **EMF TriAxial [OFF]** is **not** viewable). The **SysCtrl Triaxial** softkey is **not** editable, and indicates the System control softkeys are manually controlling a single X, Y, or Z antenna dipole for **uncorrected** use. [X, Y, or Z] is displayed to indicate which one of the X/Y/Z dipole axes is enabled. If for example the X axis has been selected in the **System** > **Utilities** > **USB Antenna** menu, then **USB Antenna [X]** is displayed to indicate the X axis measurement (i.e., this uncorrected manual mode is typically used when no EMF Option 358 is installed). Refer to **Figure 9-21**. See also step **f**.

**Figure 9-21** SysCtrl Triaxial [N] Softkey – With the X–Axis Dipole Selected



d. Modifying the Amplitude Correction Selection:

Press **Scale/Amptd** > **More** > **Corrections** > **More** then

- **Amp Corr Select [Triaxial XYZ]** - then choose one of the following:
  - **Default** Receiver side only antenna measurements.
  - **Src/Rcvr Split** to work with non-triaxial receiver and source side antenna measurements.
  - **Triaxial XYZ** (default, when Channel Power is on and when a compatible triaxial antenna's factors have been imported) for measuring channel measurements and EMF.
- Then **Back** to exit to the previous softkey menu.

**e. Optional (Triaxial XYZ Antenna):**

Verifying antenna and cable corrections are applied:

- i. Press **Scale/Amptd** > **More** > **Corrections**
  - Then verify the **Apply Corrections Auto Disabled** softkey is set to **Auto** (This is the default setting when a compatible USB antenna's correction factors have been imported, via the System softkeys).
  - Then verify the **X axis Antenna**, **Y axis Antenna**, and **Z axis Antenna** are all **ON**. These can each be enabled or disabled individually, but for EMF measurements all three axes should be enabled (i.e., Antenna = Off, the applications are setting the X/Y/Z).
  - Then Press **Cable Off** to open the cable correction softkeys menu.

Verify **Cable** is **ON**. This can be disabled for applications where an additional cable has not been connected to the triaxial antenna. Before a cable can be used with the EMF measurements it needs to have corrections loaded. If you are going to use a cable, then choose as needed:

- **Cable Off** to enable a cable for use in your antenna measurement.
- **Edit Cable** displays a cable corrections table that you can edit
- **New** displays a cable corrections table that you can edit with new cable correction content.

**Yes** – Choose **Yes** to overwrite the current cable data

SA (Spectrum Analyzer) Mode (Option 233–Mixed Analyzers)  
How to Set Up EMF Settings (Requires EMF (Option 358), GPS (Option 307), and SA Mode (Option 233–Mixed Analyzers))

**No** – Choose **No** to exit the cable data edit table view

- **Save Cable** Opens a menu to name and save the cable corrections data
- **Recall Cable** Recalls the selected cable correction file from the \Cables folder.
- **Storage Device** to select the storage device where your cable correction file is located (Internal/USB/SD Card)

ii. **Optional:** Press **More** then

- Press **View Corrections OFF ON** to turn ON and OFF Pink Trace - Antenna/Cable corrections. This is a composite of all cable/antenna corrections that are currently applied. Available as a useful visual aid, the zero “dB” level (no net correction) is mapped to appear at the -50 dBm on-screen level.
- Press **Src/Rcv Split** - selecting **Src/Rcv Split** selects Source and Receiver side measurements.

f. **Optional:** Example of editing X, Y, and Z axes manually.

## NOTE

The USB antenna factors stored in the triaxial antenna itself cannot be overwritten. The antenna factors on FieldFox imported into FieldFox can be modified. To reset the antenna factors in FieldFox to the original factors, re-import the antenna factors.

- Press **X axis Antenna** – opens the X axis Antenna softkey menus. Then choose one or more of the following:
  - **X axis Antenna** – enable/disable the X axis antenna factors (default is coupled to other settings).
  - **Edit Antenna** – to edit the current imported X factor (if available). Refer to “**Editing Antenna Correction Factors and Adding New Antenna Factors**” on page 233.
  - **New** – to edit/define a new X factor value. Refer to “**Editing Antenna Correction Factors and Adding New Antenna Factors**” on page 233.
  - **Save Antenna** – to save either an edited X antenna factor or a new X antenna factor. See also Chapter 30, “**System Settings**” and then to “**Alpha Numeric Editing**” on page 749.

SA (Spectrum Analyzer) Mode (Option 233–Mixed Analyzers)  
How to Set Up EMF Settings (Requires EMF (Option 358), GPS (Option 307), and SA Mode (Option 233–Mixed Analyzers))

- **Recall Antenna** – to recall a stored X antenna factor. See also **Chapter 30, “System Settings.”**
- **Storage Device** – to select the location to store your new antenna factor. See also **Chapter 30, “System Settings.”**

## Editing Antenna Correction Factors and Adding New Antenna Factors

This section contains two procedures illustrating how to edit the Antenna Factors settings table values.

### NOTE

If New is selected under the X, Y, or Z Antenna or Cable softkey menu, whatever antenna or cable factors that have been imported as the default values and are displayed in the Settings table.

### 1. Selecting an antenna softkey menu:

Press **Scale/Amptd** > **More** > **Corrections** then choose one of these softkey menus:

- **X axis Antenna** – to open a softkey menu to edit the X axis of a triaxial antenna.
- **Y axis Antenna** – to open a softkey menu to edit the Y axis of a triaxial antenna.
- **Z axis Antenna** – to open a softkey menu to edit the Z axis of a triaxial antenna.
- **Cable** – to open a softkey menu to edit the cable factors for an antenna setup.

### 2. For this example, the X axis Antenna softkey menu has been selected:

- Then press **Edit Antenna** to edit the existing X axial antenna factor's Frequency and Antenna Factor table values that are stored in the FieldFox [ :Internal ] : \Antenna\ directory (Refer to **Figure 9-22**). Then you can edit the following:
  - **Description** – edits the name of the current antenna settings table
  - **Antenna Factor Unit** – edits the units from dB /m electric antenna factor to dB S/m for the magnetic antenna factors. **None** is displayed, when no antenna is detected.
  - **Frequency** – edits the frequency value measured that corresponds to a particular Antenna Factor.
  - **Antenna Factor** – edits the Antenna Factor (amplitude) that corresponds to a particular frequency.

Refer to next step for details on editing the antenna Settings table.

- b. Use the ▲▼ arrows, the rotary knob, or numeric keypad to select the table cell value to be edited (i.e., the Frequency Interpolation value is not editable). Then:
- Press **Edit Antenna** to edit your existing antenna factors or press **New** to add a new antenna's factors or to write over your existing antenna's file (i.e., **Overwrite existing Antenna data?** is displayed above the table).
    - Choose **Yes** to write over the existing antenna file.
    - Choose **No** to create a new antenna file (default filename is Example).
  - Press **Add Row** to create additional Frequency and Antenna Factor values.
  - Press **Delete/Clear** then choose one of these:
    - **Delete Row** – when pressed this choice deletes the currently selected row of Frequency and Antenna Factors (i.e., you must press **Yes** to delete a row or **No** to exit the current softkey menu).
    - **Clear All** – when pressed this choice deletes all of the currently selected rows of Frequency and Antenna Factors (i.e., you must press **Yes** to deleted the rows or **No** to exit the current softkey menu).
    - **Back** – To exit to previous softkey menu.
  - Press **Done** when finished editing to exit.
- c. Press **Save Antenna** to save your changes. See also Chapter , “File Saving Naming Options” and then to “Alpha Numeric Editing” on page 749.

For more information:

- See also “GNSS (GPS+) and GPS” on page 755.

SA (Spectrum Analyzer) Mode (Option 233–Mixed Analyzers)  
 How to Set Up EMF Settings (Requires EMF (Option 358), GPS (Option 307), and SA  
 Mode (Option 233–Mixed Analyzers))

**Figure 9-22** Example Editing and Adding a New X axis antenna is shown.

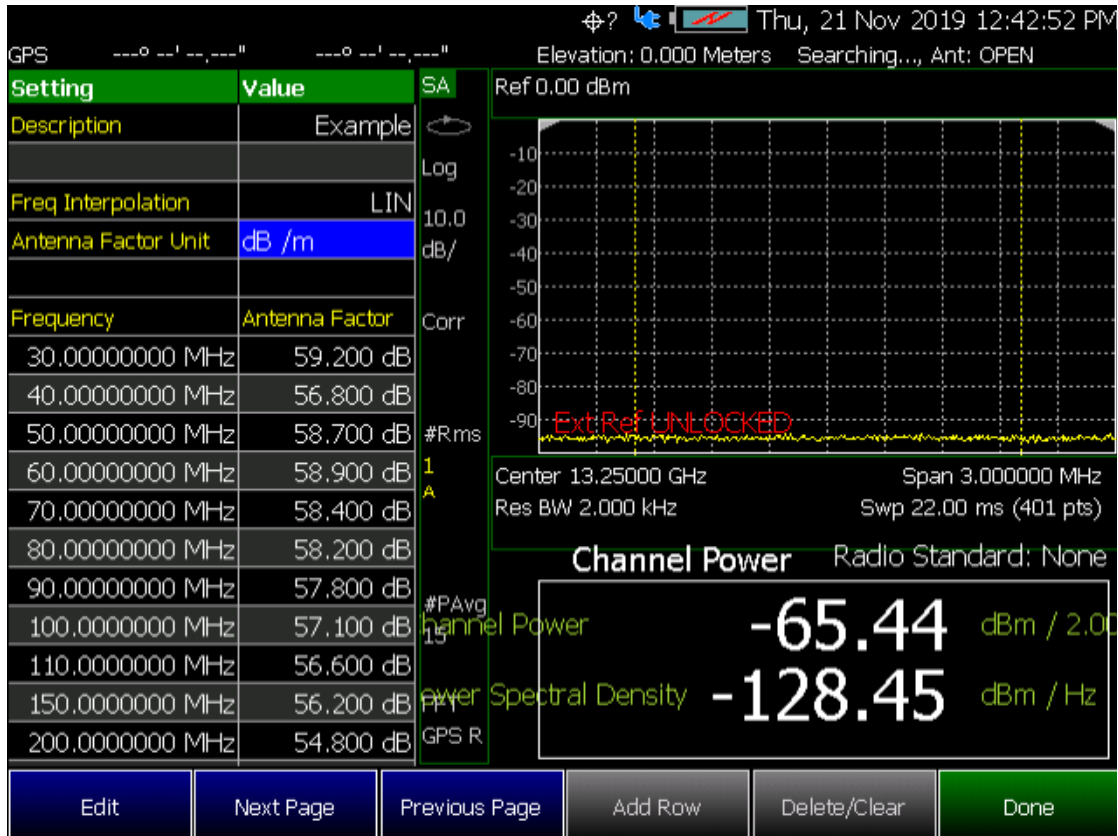

### Editing Cable Correction Factors and Adding New Cable Factors

This section contains two procedures illustrating how to edit the Cable Factors settings table values.

#### NOTE

If New is selected under the X, Y, or Z Antenna or Cable softkey menu, whatever antenna or cable factors that have been imported as the default values and are displayed in the Settings table.

#### 1. Selecting an cable softkey menu:

Press **Scale/Amptd** > **More** > **Corrections** then choose one of these softkey menus:

- **Cable Off** – to open a softkey menu to edit the cable factors for an antenna setup.

#### 2. For this example, the Cable Off softkey menu has been selected:

- a. Then press **Cable Off** > **Edit Cable** to edit the existing cable's Frequency and Cable Loss table values that are stored in the FieldFox [ :Internal ] : \Cable\ directory (Refer to **Figure 9-22**). Then you can edit the following:
- **Description** – edits the name of the current cable correction settings table
  - **Frequency Interpolation** – sets the frequency interpolation to linear or to log.
  - **Frequency** – edits the frequency value measured that corresponds to a particular Cable Loss.
  - **Cable Loss** – edits the Cable Loss value that corresponds to a particular frequency.

Refer to next step for details on editing the cable Settings table.

- b. Use the **▲▼** arrows, the rotary knob, or numeric keypad to select the table cell value to be edited (i.e., the Frequency Interpolation value is not editable). Then:
- Press **Edit Cable** to edit your existing cable loss data or press **New** to add a new antenna's factors or to write over your existing antenna's file (i.e., **Overwrite existing Cable data?** is displayed above the table).
    - Choose **Yes** to write over the existing cable file.
    - Choose **No** to create a new cable file (default filename is `Example`).
  - Press **Add Row** to create additional Frequency and Cable Loss values.
  - Press **Delete/Clear** then choose one of these:
    - **Delete Row** – when pressed this choice deletes the currently selected row of Frequency and Cable Loss (i.e., you must press **Yes** to delete a row or **No** to exit the current softkey menu).
    - **Clear All** – when pressed this choice deletes all of the currently selected rows of Frequency and Cable Loss (i.e., you must press **Yes** to deleted the rows or **No** to exit the current softkey menu).
    - **Back** – To exit to previous softkey menu.
  - Press **Done** when finished editing to exit.

SA (Spectrum Analyzer) Mode (Option 233–Mixed Analyzers)  
 How to Set Up EMF Settings (Requires EMF (Option 358), GPS (Option 307), and SA Mode (Option 233–Mixed Analyzers))

- c. Press **Save Cable** to save your changes. See also **Chapter**, “**File Saving Naming Options**” and then to “**Alpha Numeric Editing**” on page 749.

For more information:

- See also “**GNSS (GPS+) and GPS**” on page 755.

**Figure 9-23** Example: Editing and Adding a New X axis antenna is shown. But, the Cable Loss table is similar.

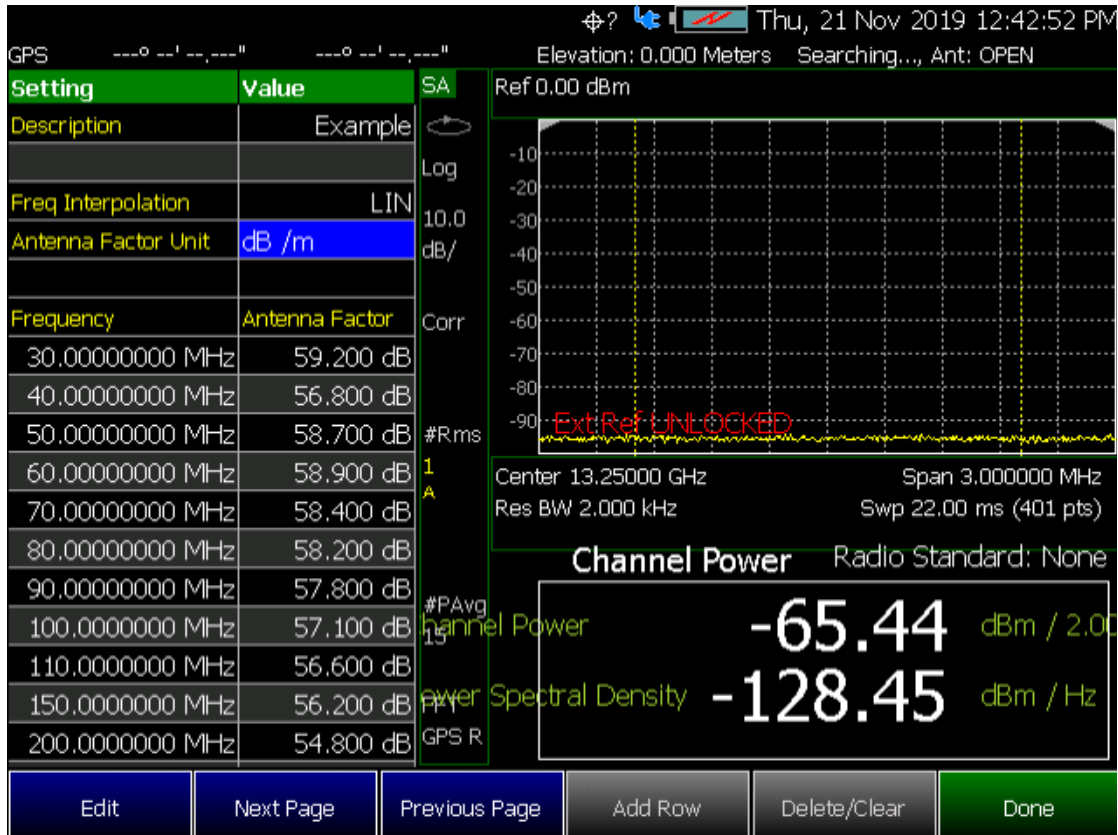

## Spectrum Emission Mask (SEM) – (SA Mode Only)

This section explains how to make the spectrum emission mask, (SEM), measurement. SEM compares the total power level within the defined carrier bandwidth and offset channels on both sides of the carrier frequency, to levels allowed by standard. Results of the measurement of each offset segment can be viewed separately.

### Purpose

The Spectrum Emission Mask measurement includes the in-band and out-of-band spurious emissions. It is the power contained in a specified frequency bandwidth at certain offsets relative to the total carrier power. It may also be expressed as a ratio of power spectral densities between the carrier and the specified offset frequency band.

The spectrum emission mask measurement is a composite measurement of out-of-channel emissions, combining both in-band and out-of-band specifications. It provides useful figures-of-merit for the spectral regrowth and emissions produced by components and circuit blocks.

### Measurement Method

The spectrum emission mask measurement measures spurious signal levels in up to 8 pairs of offset/region frequencies and relates them to the carrier power.

The integration bandwidth method is used to perform a data acquisition. The reference channel integration bandwidth (Meas BW) is analyzed using the user defined resolution bandwidth (Res BW), which is much narrower than the channel bandwidth. The measurement computes an average power of the channel or offset/region over a specified number of data acquisitions, automatically compensating for resolution bandwidth and noise bandwidth.

This measurement requires the user to specify the measurement bandwidths of carrier channel and each of the offset/region frequency pairs up to 12 (A - L). Each pair may be defined with unique measurement bandwidths. The results are displayed both as relative power in dBc and as absolute power in dBm.

### Summary

Similar to other Radio Channel measurements, SEM sweeps and measures the total power within a Reference channel. It also optionally performs sweeps of user defined offset segments both above and below the reference channel. The peak signals within the offsets are compared against limits, to determine PASS or FAIL results. Tabular data is presented showing individual offset segment results, one row for each offset. A final trace is displayed that contains all of offset segment sweeps and the reference channel sweep is formed and plotted along with the limits.

The following are displayed:

- **Total Power Ref (dBm / Hz)** - measures total power over the specified Integrated BW.

SA (Spectrum Analyzer) Mode (Option 233–Mixed Analyzers)  
 Spectrum Emission Mask (SEM) – (SA Mode Only)

- **Spectrum Emission Mask Pass/Fail** – A PASS indicates the displayed SEM is within the current boundaries specified. A FAIL indicates the current signal fails with the specified parameters.

Figure 9-24 SEM Example

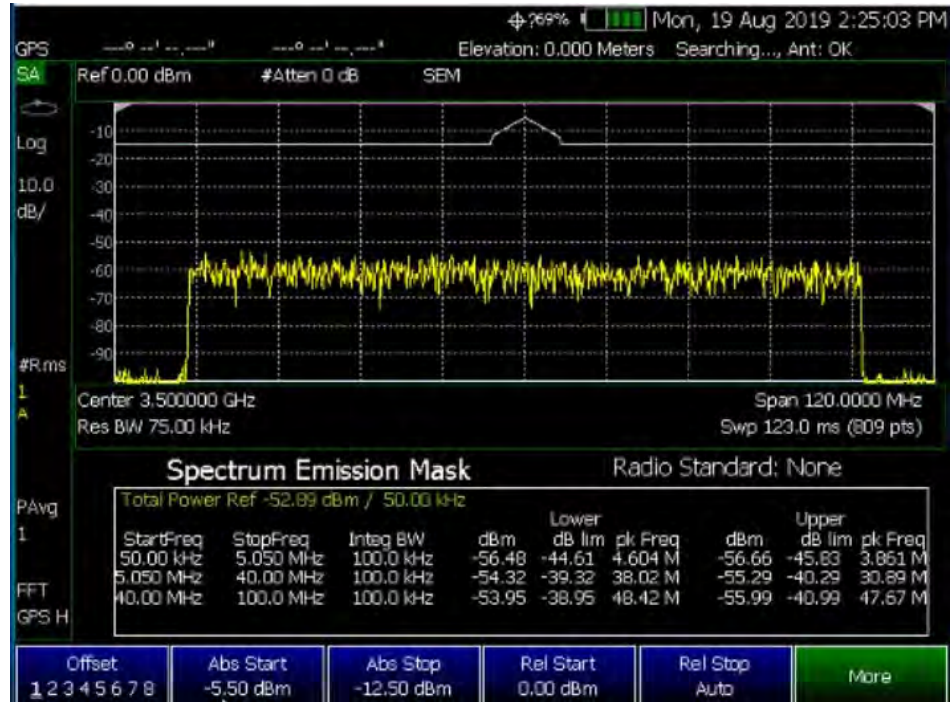
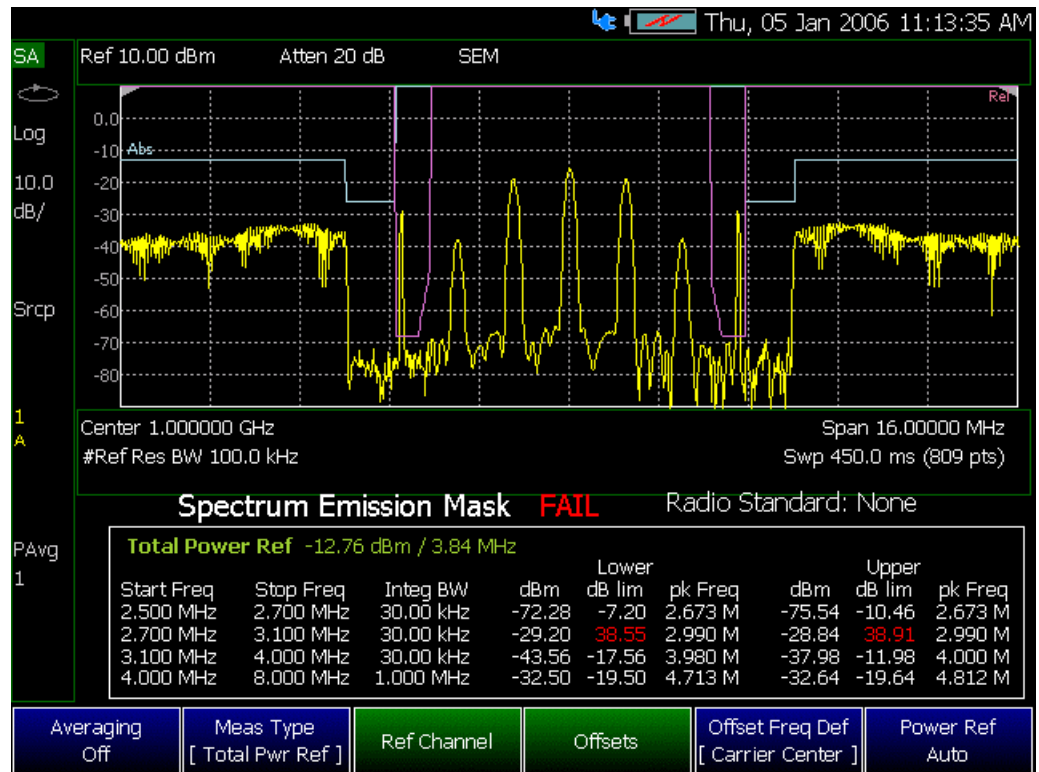

Figure 9-25

SEM Example FAIL Data - Absolute Limit (Blue), Relative Limit (Violet), Trace (Yellow), and Tabular Data



### How to select Spectrum Emission Mask (SEM) Measurement

- Press **Measure 1**
- Then **Channel Measurements**
- Then **Spectrum Emission Mask**

When SEM is selected, the following settings are maintained from a previous measurement: Center Frequency, Preamp ON|OFF, and RF Attenuation.

### Setting up the FieldFox for Spectrum Emission Mask (SEM) Measurement

1. Press **Measure 1** > **Channel Measurements** > **Spectrum Emission Mask**
2. Press **Meas Setup 4** then optionally select:
  - **Averaging** Enable/disables averaging and sets the number of trace averages (Default is OFF).
  - **Meas Type** Then select one of the following:

Measurement Type (Meas Type) enables the user to select the method used to calculate the reference power level.

**NOTE**

The displayed green power (dBm)/frequency (Hz) text changes as the Meas Type is toggled.

- **Total Pwr Ref** (Default is Total Pwr Ref) is the total integrated reference channel power (dBm) is measured and used as the Auto Power Ref value. Peaks found in Offset segments remain in (dBm) units for direct comparison with (dBm) limits.
- **PSD Ref** the power spectral density (dBm/Hz) is measured and used as the Auto Power Ref value. Absolute Limits and Peaks found in Offset segments are normalized to their equivalent PSD value (dBm/Hz).
- **Spec Pk Ref** the spectral peak value measured within the reference channel (dBm) is used as the Auto Power Ref value. Peaks found in Offset segments remain in (dBm) units for direct comparison with (dBm) limits. Values in the table are compared to the peak power of the spectrum.
- **Ref Channel** Opens the Reference Channel softkey menu. Then select one of the following:
  - **Integ BW** Sets the Integrated bandwidth.
  - **Ref Chan Span** Sets the reference channel span. usually set equal or greater than the Integ BW, it is simply a way to reserve additional freq range to be measured for display presentation, if that range is not overlapped by the offset regions. The reference channel is always measured completely as specified, but only the central part of the reference channel that is NOT overlapped by active offset regions is displayed. (Minimum = 10 Hz/ Maximum = Value varies with model and options).
  - **Carrier Center** Tracks currently displayed carrier center frequency (Default = TrackCF). Set to Hold to disable the carrier frequency tracking.
  - **Res BW** Auto/Manual (Default is Auto). Sets the resolution bandwidth. See also, “Resolution Bandwidth (Res BW)” on page 182.
- **Offsets** Opens the frequency Offsets softkey menu. Then select one of the following:
  - **Offset** Sets the number of pairs of frequencies to be offset (up to eight pairs can be selected).

- **Ofst Enable** Enables/disables the currently selected Frequency Start/Stop Offset values.
- **Ofst Freq Start** Sets the offset frequency start value. (Default/Maximum = Value varies with model and options, Minimum = 0 Hz).
- **Ofst Freq Stop** Sets the offset frequency stop value. (Default/Maximum = Value varies with model and options, Minimum = 0 Hz).
- **Res BW** Auto/Manual (Default is Auto). Sets the current resolution bandwidth value. See also, “Resolution Bandwidth (Res BW)” on page 182.
- **Offset Side Neg Both Pos** (Default is Both). Sets the offset side measurement value. Select Negative (Neg) to measure the negative side of the spectrum. Select Positive to measure the positive side of the spectrum.
- **Offset Freq Def** then select one of the following:
  - **Carrier Center** (Default) applies the frequency offsets to the current carrier center frequency.
  - **Carrier Edge** Selects the edge of the carrier for frequency offset definition.
- **Power Ref** – the reference power value can be fixed (which also fixes the Relative Limit line), but the user must then consider the unit being used (dBm or dBm/Hz) depending on the Meas Type selected. If Power Ref is left AUTO (Default) then its value will track the Meas Type and change units automatically. Both fixed and Auto settings display the power reference value measured.

### 3. Setting Center Frequency and Span

#### NOTE

Frequency control menu (Center and Span) provides an SEM Auto Span control (defaulted to ON) which automatically tracks the necessary span to cover all enabled offset segments. In the example in [Figure 9-25 on page 240](#), the necessary span is 16 MHz. But the you can de-couple the span simply by narrowing or widening Span it in order to zoom.

The Carrier Frequency (Ref Channel Center) by default tracks the specified Center Frequency, but can be forced to “Hold” at a particular location which would then allow the user Center Frequency to pan above or below for reasons similar to zooming with span.

---

Press **Freq/Dist** then

- **Center** - sets the center frequency.
- **SEM Auto Span** - Enables/disables the SEM Auto Span.
- **Freq Span** - sets the frequency span of the SEM measurement.

- **More** - optional to set Radio Standard controls. Refer to “Radio Standard” on page 153.

#### 4. Setting the Limit Lines

Two Limit traces are available, an Absolute Limit and a Relative Limit. Both are defined and applied only over the Offset measurement regions. There is no Limit definition or application for the Reference Channel itself. The final Limit Trace displayed is a concatenation of all the individual Offset Limit segments, just as the final measurement trace is. Success or Failure is determined by Fail Mask per offset, to be based on either Relative or Absolute limits, Both (Abs AND Rel), or Either (Abs OR Rel).

Press **Limit 8** then

- **Offset** - selects the offset region to be edited.

The Limits per offset are determined by Start/Stop Amplitude level endpoints, which correspond exactly to the user specified Start/Stop frequency locations in the Offsets sub-menu. So each offset segment is a LINE defined by its two endpoints. In the Limit “Auto” means to match the Start limit value, hence creating a FLAT (horizontal) Limit Line segment. But the Stop value can be manually set as well, creating sloped Limit segments.

- **Abs Start** - Sets the start of an absolute limit line segment.
- **Abs Stop** - Sets the stop of an absolute limit line segment.
- **Rel Start** - Sets the amplitude limit at the start frequency of the offset, relative to the reference power level.

#### NOTE

The reference power level is displayed in green. The reference power level type can be selected through **Measure 1** > **Meas Type**, and the reference power settings defined through **Meas Setup** > **Ref Channel**.

Example: If the reference power level reads -15 dBm, and **Rel Start** is set to -10 dB, the level is -25 dBm. Since this limit line type is relative, it moves with the reference power reading.

- **Rel Stop** - Sets the amplitude limit at the stop frequency of the offset, relative to the reference power level.
- **Fail Mask** - Sets the Fail Mask offset parameters for the measurement. Then choose:
  - **Absolute** - The absolute mask is tested for all offsets.
  - **Relative** - The relative mask is tested for all offsets.
  - **Abs OR Rel** - Either Absolute or Relative data failure generates a fail message.

- **Abs AND Rel** - Requires a relative and an absolute data failure to generate a fail message.

## 5. Setting the Detectors

The Trace menu shows that two Detector controls are available, one for the Reference Channel (default Auto is Average to facilitate the Power Integration), and another for all the Offset segments (default Auto is PEAK, to facilitate finding PEAK signal energy when comparing against Limits). There is only 1 Trace available, and like the other Channel Measurements, it is set to average.

Press **Trace 6** then

- **State** - sets the measurement state. Refer to “**Trace Display States (SA Mode)**” on page 198.
- **Default All** - Sets the SEM settings to default
- **Chan Detector** - Sets the Reference Channel detector (default Auto is Average to facilitate the Power Integration). See also “**Detection Method**” on page 208.
- **Offset Detector** - Sets all of the Offset segments (default Auto is Peak, to facilitate finding peak signal energy when comparing against the Limits). See also “**Detection Method**” on page 208.
- **Record Playback** - Refer to “**Record/Playback (SA Option)**” on page 519.

SA (Spectrum Analyzer) Mode (Option 233–Mixed Analyzers)  
IQ Analysis (Requires Option 351 IQ Analyzer and Option 353 IQ Streaming, SA Mode Only)

## IQ Analysis (Requires Option 351 IQ Analyzer and Option 353 IQ Streaming, SA Mode Only)

### CAUTION

This feature's intended use is that the Streamed data will be sent to another computer. That computer or another one will act as a SCPI controller and is required for actually controlling the streaming, in particular setting up network configuration data and starting and stopping the streaming.

---

### NOTE

#### IMPORTANT!

- IQ Streaming is used by configuring the desired setup and then starting the acquisition/data stream. In order to make measurement changes (bandwidth, center frequency, etcetera) streaming must be stopped, the new setup configured, and then streaming restarted.
  - During streaming, the data displayed on the FieldFox is not updated.
  - For both Decodio and VITA49, FieldFox encodes all streamed I and IQ data as 32-bit IEEE 754 floating point values.
  - FieldFox does not support TCP networking.
  - Data for both protocols is 2 floating point values per sample (I and Q).
  - Except for the 32-bit floating point only option for I and Q data, FieldFox implements VITA 49A a subset of the VITA 49.2 protocol.
  - While in any IQ Analysis mode, the sample rate to frequency span will stay locked/coupled in a ratio of 1.25:1.
- 

### How to Select IQ Analysis

- Press **Meas Setup 4**
- Then **IQ Analysis** then choose from
  - Then **General** –
  - Then **Streaming** – to emit a sequence of packets from a specific location in a VRT (VITA49) enabled architecture (e.g., VRT packet class with a defined packet attribute used in one or more places in a architecture to create packet streams).

When IQ Analysis is selected, the following settings are maintained from a previous measurement: Center Frequency, Span, BW, Sample Rate, Preamp ON/OFF, and RF Attenuation.

SA (Spectrum Analyzer) Mode (Option 233–Mixed Analyzers)  
IQ Analysis (Requires Option 351 IQ Analyzer and Option 353 IQ Streaming, SA Mode Only)

## How to Setup IQ Analysis General

General setup for IQ Analysis:

1. Press **Meas Setup 4** > **IQ Analysis** > **General**
2. Press **IQE Sample Rate** > Auto (default).
3. Press **Average Count** > 10 (default). Learn more refer to “Adjusting the Measurement Setup Settings” on page 299.
4. Press **Average Type** > Auto (default). Learn more refer to “Adjusting the Measurement Setup Settings” on page 299.
5. Press **Freq/Dist** > **Center** > 1 GHz
6. Press **Freq Span** > 1 MHz (default).

## How to Setup IQ Analysis Streaming

### CAUTION

This feature’s intended use is that the Streamed data will be sent to another computer. That computer or another one will act as a SCPI controller and is required for actually controlling the streaming, in particular setting up network data and starting and stopping the streaming.

The feature provides continuous streaming of IQ data up to 1.25 MSamples/sec over the Ethernet port in either VITA49A or Decodio formats.

If locked to GPS, will populate the timestamp applied to streamed data packets. If **not** locked to GPS, the system clock time is used to stamp the streamed data packets. Refer to **Chapter 30, “System Settings”** and to “Frequency Reference” on page 748.

General setup for IQ Streaming:

1. Press **Meas Setup 4** > **IQ Analysis** > **Streaming**
2. Then **IQE SampRate** > **Manual** > 1.25 MHz (default when set to **Auto**).  
Setting the IQE sample rate to **Manual**, forces the Span to be:  
 $\text{Span} = 0.8 * \text{Sample rate}.$
3. Configure Center Frequency, Span, Preamp, and RF Attenuation
  - a. Press **Freq/Dist** > **Center** > 1 GHz
  - b. Press **Freq Span** > 1 MHz (default).

This forces the Span to be:

$\text{Span} = 1.25 * \text{Span}.$

SA (Spectrum Analyzer) Mode (Option 233–Mixed Analyzers)  
IQ Analysis (Requires Option 351 IQ Analyzer and Option 353 IQ Streaming, SA Mode Only)

a. Then to adjust receiver gain:

**CAUTION**

Typically, the goal is to be able to see the desired signal that you want to capture as close as possible to the top of the display grid on the screen, without causing an ADC over range to be displayed. This maximizes the signal-to-noise ratio.

Press **Scale/Amptd** then

- To configure automatically: Press **Ref Level** – adjust as needed.

or

To adjust manually:

- Press **Preamp ON** (default = OFF)
- Press **RF Atten** > Manual > 15 dB (default)

4. Setup IQ Streaming protocol, destination host, and port:

To set the destination host, IQ streaming protocol, and samples per packet, refer to the [ :SENS ] : IQST subsystem commands in the [FieldFox Handheld Analyzer SCPI Programming Guide](http://www.keysight.com) on [www.keysight.com](http://www.keysight.com).

- Destination Host
- Destination Port – (default is 4991)
- Protocol – Choose Vita or Decodio
- Samples per packet

5. Start Streaming: Refer to the [FieldFox Handheld Analyzer SCPI Programming Guide](http://www.keysight.com) on [www.keysight.com](http://www.keysight.com).

6. When done press **Exc** to stop streaming or refer to the [FieldFox Handheld Analyzer SCPI Programming Guide](http://www.keysight.com) on [www.keysight.com](http://www.keysight.com).

Or via the FieldFox front panel, choose:

- Press **Meas Setup 4** > **IQ Analysis** > **None**

Or simply choose:

- Press **Measure 1** > **All Meas Off**

## Effective Isotropic Radiated Power (EIRP) – (SA Mode Only)

### How to Select Effective Isotropic Radiated Power (EIRP)

- Press **Measure 1**
- Then **Channel Measurements** > **More** > **EIRP** to open a menu of softkeys to set up EIRP.

### How to Setup EIRP (Effective Isotropic Radiated Power)

General setup and an example for EIRP:

For this example we are using an isotropic antenna with the following specifications:

- Frequency range: 9 kHz to 9 GHz isotropic antenna
- Preamplifier stages: 2 (+15 dB each (@2 GHz))
- Chop/Switch speed rate: 1 Hz to 50 kHz
- Assume: 600 Series 50  $\Omega$  coaxial cable with 2.5 dB/100 feet

1. Press **Measure 1** > **Channel Measurements** > **Channel Power** > **More** > **EIRP** then choose from the following:

- **EIRP Meas** – Enables and disables the EIRP measurement.
- **Rx Ant Gain** – Enter the receiver antenna gain (–100 dB to 100 dB; default = 0 dB).

For this example: **30 dB** > **Enter**.

- **Dist to Ant** – Enter the distance between the receiving and transmitting antennas (0 m to 25 km; default = 100m)

For this example: **100m** (default)

- **Rx Cable Loss** – Enter the receiver cable loss (0 to –100 dB; default = 0 dB).

For this example: **2.5 dB**

- **Margin Comp** – Enter the margin compensation to remove known self-interference, antenna efficiency, fading and other errors (–100 dB to 100 dB; default = 0 dB).

- Then **More** and choose from the following:

- **Restart** – Press this softkey to restart an antenna measurement.

- **Save Horizontal** – Saves the current horizontal EIRP value (dBm).
  - **Save Vertical** – Saves the current vertical EIRP value (dBm).
  - **Clear H & V** – Clears the saved horizontal and vertical EIRP values (dBm).
2. Configure Center frequency, Span, Preamp, and RF Attenuation
- Press **Freq/Dist** > **Center** > 2 GHz
  - Press **Freq Span** > 3 MHz (default)
  - Press **Scale Amptd** > **Preamp** > **ON** (default = OFF)
  - Press **RF Atten Auto** (default = Auto)
3. Summary of EIRP setup, per step 1.
- Press **Rx Ant Gain** For this example: 30 dB > **Enter**.)
  - Press **Dist to Ant** For this example: 100m (default)
  - Press **Rx Cable Loss** For this example: 2.5 dB
  - Press **Margin Comp**
4. Start EIRP: Press **Restart**
5. When done press:  
**Save Horizontal** and  
**Save Vertical**
6. Optional: To clear the saved horizontal and vertical EIRP values press:  
**Clear H & V**

SA (Spectrum Analyzer) Mode (Option 233–Mixed Analyzers)  
Effective Isotropic Radiated Power (EIRP) – (SA Mode Only)

## 8 Data Analysis Features

The following features can be used after a measurement to analyze the results.

### **In this Chapter**

- “How to create Markers” on page 700
- “How to move a Marker after it is created” on page 700
- “About Delta Markers” on page 701
- “Marker Table” on page 702
- “Coupled Markers (NA Mode)” on page 703
- “Marker Trace (CAT, NA, NF Modes)” on page 704
- “Marker Trace (IQA and SA Mode)” on page 704
- “Marker Format” on page 705
- “Searching with Markers” on page 706
- “What Is a ‘Peak’” on page 711
- “Marker Functions” on page 713
- “SA Marker Functions” on page 714
- “How to Create Fixed Limit Lines” on page 715
- “Relative Limit Lines” on page 716
- “Build From Trace” on page 716
- “Limit Options” on page 717
- “How to Save and Recall Limits” on page 718
- “How to display data and memory traces” on page 720
- “How to perform Trace Math ” on page 720
- “About Math Operations” on page 721
- “How to Use Scale Settings” on page 722

## All about Markers

Markers move along the X-axis range of the measurement trace to provide a numerical readout of each measured data point. Markers also allow you to search for specific Y-axis values.

A trace can contain up to six markers.

The marker readout on the FieldFox screen displays X and Y-axis information for the current active marker ONLY.

A Marker Table can be displayed that allows you to simultaneously view X and Y-axis information for all markers.

Markers can be used in **CAT, I/Q Analyzer, NA, NF, RTSA, SA**, and **Pulse Measurements** Modes.

### How to create Markers

- Press **Marker**.
- Then **Markers 1...6** to select a marker to activate.
- Then **Normal** to activate that marker. A marker is created on the trace in the middle of the X-axis. That marker is now **active**.
- Then move the marker using the rotary knob, the **▲▼** arrows, or by entering an X-axis position with the number keys.
- Then press **Enter**.

### How to move a Marker after it is created

- Press **Marker**.
- Then **Markers 1...6** repeatedly until the marker of interest is selected. The OFF, Normal, or Delta softkey is black to indicate the current setting of each marker.
- Then move the marker as when it was first created.
- Markers can also be moved using one of the marker search functions. Refer to **“Searching with Markers” on page 706**.

Figure 29-1 Marker 2 is Active, marker 1 is NOT active.

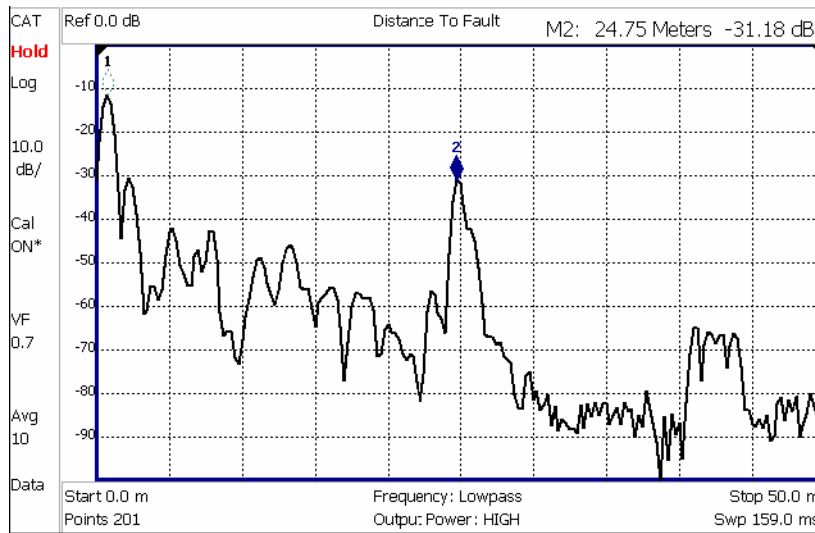

### About Delta Markers

A Delta marker provides X-and Y-axis readout information that is **relative** to a 'reference' marker.

A Delta marker is created with a  $\Delta$  (delta symbol) to distinguish it from the reference marker.

All six markers can be a Delta marker pair.

Peak search functions can be performed using delta markers.

Figure 29-2 A Delta marker and its associated reference marker.

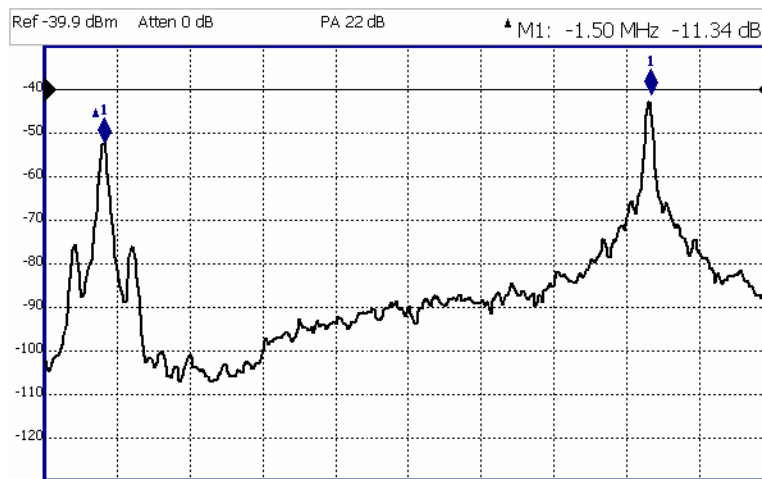

In the graphic above, the marker readout shows the difference between the two markers in frequency and amplitude.

## How to Create a Delta Marker

- Create a **Normal** marker and move it to the reference position.
- Press **Delta**. The marker becomes the reference marker and fixed in its X-Axis position.
- Move the **Delta** marker using the numeric keypad, the **▲▼** arrows, or the rotary knob.
- Press **Enter** when finished.

## How to move the Reference marker

- Press **Normal** to turn the Delta marker OFF.
- Move the marker to the new position.
- Then press **Delta** again, to turn the Delta marker back ON.

## Fix the position of the Reference marker (I/Q Analyzer, RTSA, and SA Modes ONLY)

In SA mode, the reference marker can be fixed at the Y-axis position of the data trace when the marker was created, or it can ‘float’ with each sweep at the Y-axis position of the data trace. In CAT and NA mode, the reference marker always floats with the data trace.

- Create a Delta marker.
- From the **Mkr ->/Tools** menu, press **More** (SA mode only), then **Marker Properties**, then **Delta Ref Fixed**
  - **OFF** – The reference marker floats at the data trace Y-axis position.
  - **ON** – The reference marker is fixed at the Y-axis position of the data trace when the marker was created (default IQA and SA modes).

## Signal Track Marker (NF and SA Mode ONLY)

In NF and SA mode, the marker can be peaked at the Y-axis position of the data trace and the marker is centered on the screen. This setting applies to all NF and SA markers.

- Create a Signal Track marker (peak).
- From the **Mkr ->/Tools** menu, press **More**, then **Marker Search**
  - **OFF** – The reference marker floats at the data trace Y-axis position.
  - **ON** – The reference marker is peaked at the Y-axis position of the data trace and the marker is centered on the screen.

## Marker Table

The Marker Table can be displayed at the bottom of the FieldFox screen. It can display information for up to 6 markers in a full-width window, and up to 3 markers for a half-width window (NA mode). The marker table “squeezes” the graticule area when activated.

## How to display the Marker table

- Press **Marker**.
- Then **More**
- Then **Marker Table On Off**.

### Coupled Markers (NA Mode)

#### NOTE

I/Q Analyzer (IQA) mode has coupled markers. but the behavior is different than the NA mode Coupled Markers behavior. Refer to **“Coupled Markers (Waveform Only)”** on page 307.

Coupled Markers, available in NA mode only<sup>1</sup> and allows you to simultaneously create and move markers that have the same number for all traces. For example, when marker 2 is created on a trace, a marker 2 is created for ALL traces. When any marker 2 is moved, they all move together to the same X-axis position.

- Coupled markers are allowed only in NA mode and are relevant only in multi-trace configurations.
- You can have markers that are coupled and others that are uncoupled.
- Peak functions move the marker to the peak on the active trace, while all other markers move to the same X-axis position.

Figure 29-3 Coupled Markers move on ALL traces at the same time (NA shown).

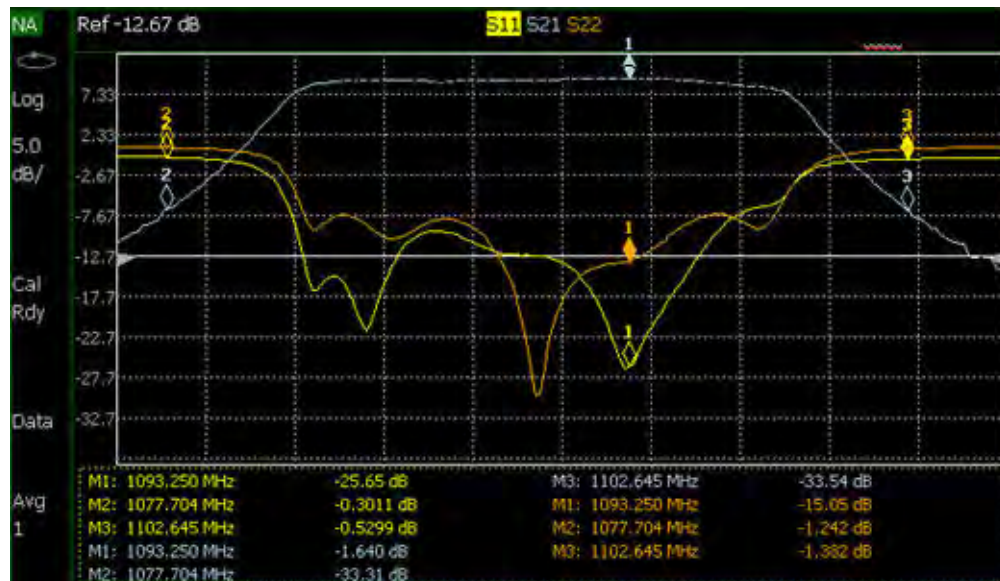

1. IQA mode has coupled markers, but the behavior is different than NA mode's coupled markers. Refer to **“Coupled Markers (Waveform Only)”** on page 307.

## How to create Uncoupled Markers

### NOTE

Markers are coupled by default.

---

To create markers that are NOT coupled (move independently on each trace):

- Press **Marker**
- Then **More**
- Then **Coupled Markers OFF**

### Marker Colors

As shown in the above image, in NA and CAT Modes, markers are the same color as the trace to which they are assigned. In SA Mode, the marker color is NOT the same as the trace.

Marker colors can NOT be changed.

### Marker Trace (CAT, NA, NF Modes)

The Marker Trace setting is used to move markers between the data trace and memory trace.

When Coupled Markers is ON, this setting applies to the active marker for ALL traces that are coupled. Otherwise, this setting applies to the active marker on only the active trace.

## How to move a CAT, NA, and NF mode marker between traces

- With at least one marker present, press **Marker** then **More**.
- Then select the marker to move using **Marker 1,2,3,4,5,6**.
- Then toggle **Marker Trace Auto Data Mem**.
  - **Auto** - Marker resides on data trace when it is visible. Marker resides on memory trace when only IT is visible (Default setting).
  - **Data** - Marker resides on data trace, even when not visible.
  - **Mem** - Marker resides on memory trace, even when not visible.

### Marker Trace (IQA and SA Mode)

Marker Trace determines the trace number on which a marker resides. A marker is created on, or can later be changed to, the trace number specified by the Marker Trace selection. When changed, a marker moves to the same X-axis location on the specified trace.

Learn more about IQA Traces in [“Trace Display States \(IQA Mode\)” on page 310](#).

Learn more about SA Traces in [“Trace Display States \(SA Mode\)” on page 198](#).

## How to move an IQ and SA mode marker between traces

- With two or more traces present, press **Marker** and **Enter** to create a marker. The marker is created on the current Marker Trace selection (default setting is 1).
- Then **More**
- Then select the marker to move using **Marker 1,2,3,4,5,6**.
- Then toggle **Marker Trace 1,2,3,4**
  - The selected marker is moved to the specified trace.
  - When a marker is moved to a 'blank' trace (not visible) the marker moves to the same X-axis position at either the Y-axis position of the last data, or to the ZERO position.

## Marker Format

The Marker Format setting allows you to choose the format of the marker readout that appears in the upper-right corner of the screen and in the marker table. The marker format can be independent of the trace format, and can be set independently for each trace. All markers on a trace have the same marker format.

## How to choose marker format

- Press **Marker**
- Then **More**
- Then **Marker Format**
- For **NA Mode** measurements, choose from the following:

Selection	Example Y-axis value
<b>Default</b> Same as displayed format	
<b>R + jX</b> Complex impedance format (3rd number is distance for Time Domain)	<b>22.8Ω -j61.4Ω</b> <b>287.9fF</b>
<b>Z Magnitude</b> Impedance Mag.	<b>66.08Ω</b>
<b>Phase</b>	<b>73.8°</b>
<b>Real</b>	<b>0.2003</b>
<b>More</b>	
<b>Imaginary</b>	<b>-0.6727</b>
<b>Mag &amp; Phase</b>	<b>0.705, -73.7°</b>
<b>dB Angle</b>	<b>-2.1 dB, -138.2°</b>

There are more trace formats available than marker formats. To display marker readouts in more formats than are shown here, change the trace format, then select **Default**. Learn how to change format in **“Format” on page 98**.

- For **TDR (CAT) Mode**, choose from **Default** and **Z Mag**.

## Searching with Markers

Marker Searches are used to move markers to locations on the trace which exhibits the characteristics of the search criteria. Learn ‘What is a Peak’ in **“What Is a ‘Peak’” on page 711**.

### How to Search with Markers

The following menu structure applies to NA Mode. Keystrokes will be slightly different for CAT, Pulse Measurements, and SA Modes.

- Activate the marker to be used for the search (NOT necessary with Bandwidth search.)
- Then press **Mkr ->/Tools**.
- Then choose one of the following:
  - **Tracking ON OFF** (NA Mode ONLY)
    - **ON** causes the active marker to search for the specified criteria with each new sweep. Search criteria can include: Target, Bandwidth, Peak, Min. The searches begin with the first sweep after Tracking is turned ON, based on the current search type. **Trk** appears next to the marker number.
    - **OFF** causes a new marker search only when the search feature is re-executed.
  - **Peak** Moves the active marker to the HIGHEST amplitude data point of the trace. Peak Excursion and Peak Threshold value is ignored. In SA Mode, the LO feed-through signal (0 Hz) is also ignored.
  - **Next Peak** Moves the active marker to the next highest amplitude data point of the trace. Peak Excursion value is ignored.
  - **Mkr -> Center** Moves the current active selected marker to the center frequency for the current frequency range displayed.
  - **Mkr -> RefLev** Moves the current active marker to the acquisition.
  - **Minimum** (Not available in DTF, RTSA, SA, or I/Q Analyzer) Moves the active marker to the LOWEST amplitude data point of the trace.
  - **Min Search** (I/Q Analyzer, RTSA, and SA modes Only) Moves the active marker to the LOWEST amplitude data point of the trace. If a marker is turned off, it is turned on before the minimum search is performed.
  - **Target** (NA Mode and Pulse Measurements ONLY) Enter the Target value. The marker moves to the first occurrence of the Target value to the right of its current position. The FieldFox interpolates between measured data points to find the exact Target value to two decimal points. The interpolated X-axis value is displayed in the marker readout or marker table. Subsequent presses of the Target softkey cause the marker to move to the right to

find the next occurrence of the Target value. When the marker reaches the end of the stimulus range, it “wraps around” and continues the search from the beginning of the stimulus range.

- **Bandwidth ON OFF** (NA Mode ONLY) Use to quickly toggle BW Markers ON and OFF. When OFF, the marker table appears showing the X and Y-axis positions of all enabled markers.
- **Bandwidth** (NA Mode ONLY) Specify the level in dB from the peak or valley where bandwidth is measured.
  - **Negative** numbers search for a **Peak** bandpass, such as a filter S21 response.
  - Either of the following TWO methods can be used to search for a **Valley** or Notch filter, such as the S11 response of a bandpass filter.
  - **Negative** values search down from the TOP (MAX) of the response.
  - **Positive** values search up from the BOTTOM (MIN) of the notch.
  - If you first enter Negative, then Positive values, it may be necessary to press **Marker**, then **More**, then **Markers All Off**.

Figure 29-4 S21 of a filter with BW Markers and associated readout values. The search criteria is -3 dB.

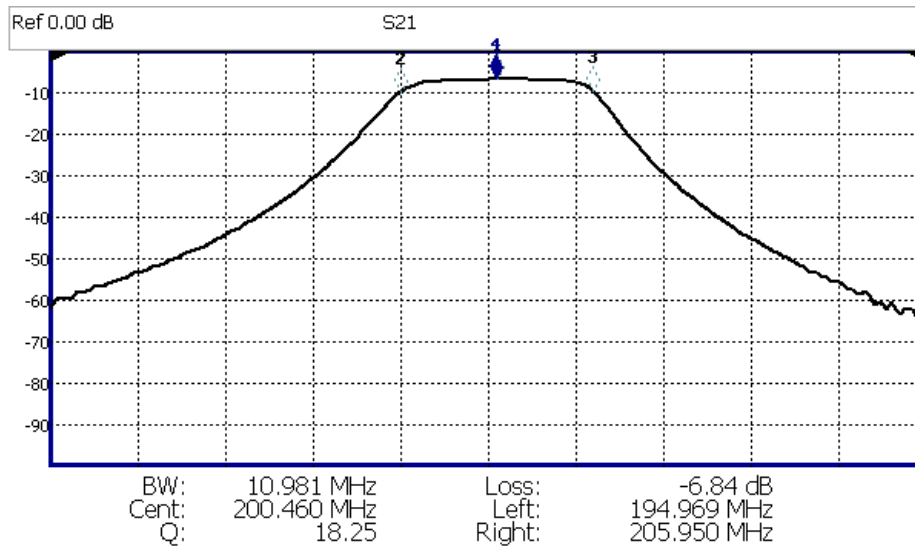
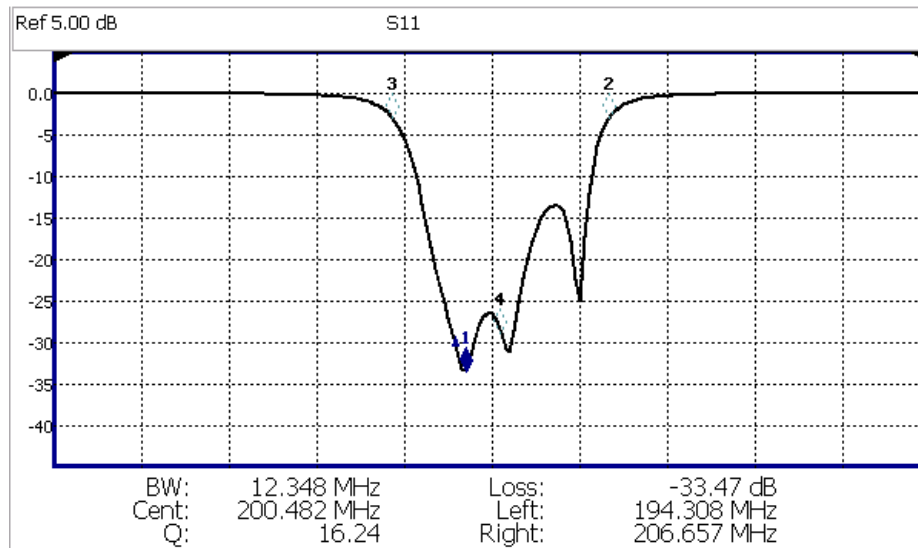

Figure 29-5

S11 of the same filter with same search criteria: -3 dB.  
The same values would result from a search criteria of approximately +30.4 dB.



After pressing **Bandwidth**, four markers are automatically created to find the first negative or positive bandpass over the displayed frequency range.

Bandwidth Search can be used ONLY with Log Mag display format.

- The following six values are displayed for Bandwidth Search:
  - **BW**: Width of the filter. (marker 2 freq) **minus** (marker 3 freq).
  - **Center**: Marker 4 frequency. Mathematical midpoint between marker 2 and marker 3.
  - **Q**: Center Frequency / Bandwidth.
  - **Loss**: Marker 1 amplitude.
  - **Left**: Frequency of marker 2 or 3 (to left of marker 1).
  - **Right**: Frequency of marker 2 or 3 (to right of marker 1).
  - Press **Back** to return to the previous menu.

Press **Peak Search** then choose from the following:

- **Peak** Moves the active marker to the HIGHEST amplitude data point of the trace. Peak Excursion value is ignored. In SA Mode, the LO feed-through signal (0 Hz) is also ignored.
- **Next Peak** Moves the active marker to the next highest amplitude peak from where it currently resides.
- **Peak Left** (Not IQA) Moves the active marker to the next data point to the left that meets the 'Peak' criteria. When no data points to the left meet the 'Peak' criteria, the marker does not move.

- **Peak Right** (Not IQA) Moves the active marker to the next data point to the right that meets the 'Peak' criteria. When no data points to the right meet the 'Peak' criteria, the marker does not move.

The following applies to DTF Measurements ONLY:

- **More** then:
  - **Track Peaks ON OFF** When Track Peaks is ON, markers will find the new peak with every sweep. While in this Mode, the markers can NOT be turned OFF or moved.
  - **Find 3 Peaks** Three markers are created and find the highest peaks (faults) on the trace.

The following applies to IQA Measurements ONLY:

- **More** then:
- **Min Search** Moves the active marker to the minimum frequency (IQA displays time) currently displayed on the screen.
- **Mkr Properties** then:
  - **Peak Criteria** then refer to **“How to set Peak Criteria” on page 711:**
  - **Delta Ref Fixed** Enables or disables the delta reference fixed marker.
- **Peak Left** (IQA Spectrum Only) Moves the active marker to the next data point to the left that meets the 'Peak' criteria. When no data points to the left meet the 'Peak' criteria, the marker does not move.
- **Peak Right** (IQA Spectrum Only) Moves the active marker to the next data point to the right that meets the 'Peak' criteria. When no data points to the right meet the 'Peak' criteria, the marker does not move.

**Using Mkr5/Mkr6 to find mins/maxs between Mkr1 and Mkr2 / Mkr3 and Mkr4 (CAT and NA Mode)**

Use this feature to search minimum and maximum values within sub-spans defined by Mkr1 and Mkr2, and Mkr3 and Mkr4. This facilitates measuring minimum and maximum values on your uplink and downlink channels, or only in the passband of a DUT. Use in conjunction with marker table and limit lines to verify your DUT's signals and to adjust or tune as needed. See also, **“All about Limit Lines” on page 715.**

When markers are set to Normal, Mkr5 and Mkr6 can be used to find the minimum and or maximum values between Mkr1 and Mkr2 (using Mkr5) and Mkr3 and Mkr4 (using Mkr6). Refer to [Figure 29-6 on page 711](#).

**NOTE**

If your Markers are positioned and in Normal marker mode, no changes are made to the Mkr1 through Mkr4 settings.

If your Markers are not previously positioned and in Normal marker mode, when you select the Mkr5 and Mkr6 maximum and minimum setting, your markers are set as follows:

- Markers are all set to **Normal**
- Mkr1 and Mkr3 are set to 1/4 full span
- Mkr2 and Mkr4 are set to 3/4 full span

How to use the Mkr5 and Mkr6 markers to find maximums and minimums between your Normal markers (CAT and NA Mode):

This section assumes you understand the previous marker features. And, that you have previously positioned your markers (Mkr1 and Mkr2 or and Mkr3 and Mkr4) and set the markers up as **Normal** markers using [“How to create Markers” on page 700](#) and other previous marker sections. For example, if your markers are set to **Delta**, change to **Normal**, and verify the marker positions are correct. Refer to [Figure 29-6 on page 711](#).

- Then press **Mkr ->/Tools**.
- Then **More** (For DTF, TDR measurements, and NA Mode, skip this step and proceed to the next step.)
- Then **Mkr5 & Mkr6 Search**
- For Mkr1 & Mkr2 maximum or minimum value search:
  - Then **Mkr5 Peak** or
  - **Mkr5 Min**
- Or for Mkr3 & Mkr4 maximum or minimum value search:
  - Then **Mkr6 Peak** or
  - **Mkr6 Min**

Figure 29-6 CAT Mode Mkr5 and Mkr6 Search Example

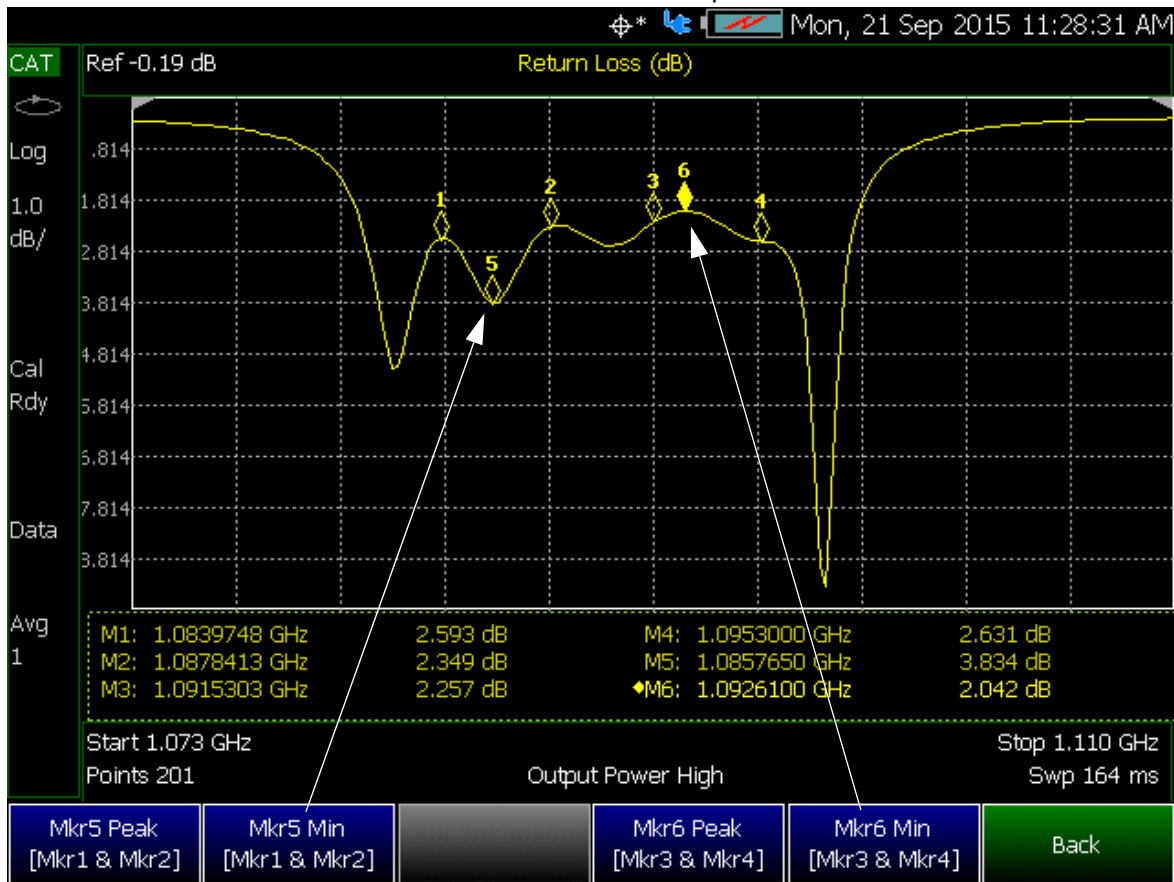

### What Is a 'Peak'

You define what the FieldFox considers a "peak" by setting the Peak **Threshold** and Peak **Excursion** and for I/Q Analyzer Only **Cont Peak Search**.

These two peak criteria settings are set individually for each trace and for each mode (CAT, SA, or NA).

These settings do NOT survive a FieldFox or Mode Preset.

#### NOTE

The Peak Threshold and Excursion settings are NOT available in DTF measurements. To make these settings, create a non-DTF CAT mode measurement, then change the measurement back to DTF.

### How to set Peak Criteria

- Press **Mkr ->/Tools**.
- In **CAT** and **NA** modes:
  - Then **Peak Search**.
  - Then **Peak Criteria**

- In **IQA** (Spectrum) and **SA** mode:
  - Then **More**
    - Then **Mkr Properties**
    - Then **Peak Criteria**
- In **IQA** (Waveform) mode:
  - Then **Mkr Properties**
    - Then **Peak Criteria**

After selecting Peak Criteria for CAT, IQA, NA, or SA mode:

- Then select the following:
  - Peak Threshold** Minimum amplitude (dB). To be considered valid, the peak must be above the threshold level. The valley on either side can be below the threshold level.  
Default = -190 for CAT and NA Modes; -90 for SA Mode.

**NOTE**

CAT mode Loss measurements are displayed in positive values. In these cases, the Peak Threshold setting is inverted. For example, Peak Threshold = -20 will consider any peak that has less Loss than 20 dB to be valid.

- Peak Excursion** The vertical distance (dB) between the peak and the valleys on both sides. To be considered a peak, data values must “fall off” from the peak on both sides by the excursion value. Default = 0.5 dB for CAT and NA Modes; 6 dB for SA Mode.
- Cont Peak Search** (I/Q Analyzer Only) Enables or disables the Continuous Peak Search marker. When Continuous Peak Search is on, a peak search is automatically performed for the selected marker after each sweep. The rules for finding the peak are exactly the same as for Peak Search, including the use of peak criteria rules. See also, **“Using Markers (IQA)” on page 305.**
- Delta Ref Fixed** Enables or disables the delta reference fixed marker.

**Peak Excursion and Peak Threshold example**—the settings for the trace in the following image are:

- Threshold: -10 dB
- Excursion: 1 dB
- Scale = 1 dB / Division.

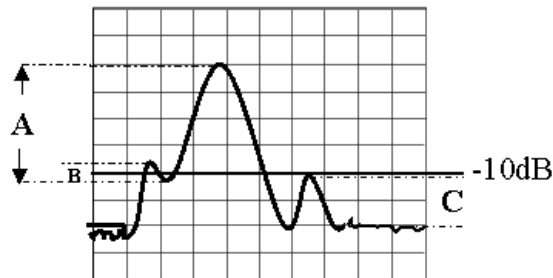

Peak A = **Valid Peak** (Above Threshold and Excursion Settings)

Peak B = **Invalid Peak** (Below 1 dB Excursion Setting)

Peak C = **Invalid Peak** (Below -10 dB Threshold Setting)

## Marker Functions

Marker functions are used to change FieldFox frequency or distance settings to those of the active marker.

### How to use Marker Functions

- Activate the marker to move.
- Then press **Mkr ->/Tools**
- Then **Mkr ->** (this step **not** required for all modes)

Then choose one of the following:

- **Mkr -> Center** (**Not** available in DTF, I/Q Analyzer (waveform), or SA mode with zero span) The center frequency of the measurement becomes the value of the active marker. The frequency span is adjusted accordingly.
- **Mkr -> Delay** (NA mode ONLY.) The group delay value of the active marker becomes the electrical delay setting of the trace. Learn how to set group delay format in **“Calibration Settings” on page 97**. Learn more about electrical delay in **“Electrical Delay” on page 101**.
- **Mkr-> RefLev** (IQ Analyzer (NOT waveform) and SA mode ONLY) The acquisition becomes the magnitude of the active marker.
- **Mkr-> TuneFreq** (SA mode with Tune & Listen ONLY) The Tune & Listen Frequency becomes the frequency of the active marker (When **AM Metrics** or **FM Metrics** are selected this softkey is inactive).

The following applies to DTF Measurements ONLY:

- **More** then:
- **Mkr->Start Distance** The Start Distance of the measurement becomes the value of the active marker. Markers that would no longer appear on the screen are moved to the new Start Distance.
- **Mkr->Stop Distance** The Stop Distance of the measurement becomes the value of the active marker. Markers that would no longer appear on the screen are moved to the new Stop Distance.

### I/Q Analyzer (IQA) Marker Functions

The following Marker Functions are available in I/Q Analyzer Mode ONLY (exceptions are noted):

- Noise Marker (Available in SA mode)
- Band/Interval Power Marker (Available in SA mode)
- Coupled Markers
- Band Span
- Interval Band Span
- Continuous Peak Search

Learn more about Noise and Band/Interval Power marker functions starting in the IQA chapter here: **“Noise Marker” on page 305.**

### SA Marker Functions

The following Marker Functions are available in SA Mode ONLY (exceptions are noted):

- Noise Marker (Available in I/Q Analyzer mode)
- Band/Interval Power Marker (Available in I/Q Analyzer mode)
- Frequency Counter at Marker
- Audio Beep with Marker
- Time Zero Fixed Marker

Learn more about these marker functions starting in the SA chapter here: **“Noise Marker” on page 211.**

## All about Limit Lines

Limit lines are visual representations, drawn on the FieldFox screen, of the specified limits for a measurement. With this capability, you can easily compare measured data versus specifications. Optionally, you can enable an audible beep and display **Pass or Fail** information for each measurement.

### NOTE

**IMPORTANT!** For CAT and NA modes, limit lines do not apply where  $F1 = F2$ .

- You can have up to as many limit line segments as there are data points for each measurement trace allowing you to test all aspects of your measurements.
- Limit lines are available in CAT Mode, NA Mode, NF Mode, and SA Mode. Power Meter Mode uses different limit settings. Learn more in [“Limits” on page 552](#).
- Limit lines and limit testing are NOT allowed in NA Mode with **Smith Chart** or **Polar** display formats.
- A simple Display Line is also available in I/Q Analyzer, NF, and SA Modes ONLY. Learn more in [“Display Line \(I/Q, NF, and SA Modes Only\)” on page 719](#).
- Limit lines can be saved and recalled with an \*.sta file. Learn more in [“How to Save and Recall Limits” on page 718](#). They can also be saved and recalled independently from the Limit softkeys. Learn more in [“How to Save and Recall Limits” on page 718](#).

### How to Create Fixed Limit Lines

There are two ways to build a Fixed limit line:

1. **Build (limits) From a Trace.** Learn how in [“Build From Trace” on page 716](#).
2. **Enter X/Y data points into the on-screen editor.** The limit line is formed as the FieldFox ‘connects the dots’ on the screen. To create frequency gaps that are NOT tested, use separate limit lines. The X-axis values for two lines can overlap.
  - Press **Limit 8**.
  - Then **Edit Limits**. A limit line table appears.
  - Use the Up / Down arrows and rotary knob to navigate the cursor to the following editable cells.
    - **Description** – Press **Edit**, then enter a description for the limit line using the FieldFox labeler. Learn how in [“How to use the FieldFox labeler ” on page 780](#).
    - **Fixed/Relative** – Press **Edit** to toggle between the following:
      - **Fixed** – (Default) the limit line does not move. The X/Y coordinates are absolute locations on the screen.
      - **Relative** – the limit line moves relative to the center frequency and acquisition.  
**Note:** It is easiest to first create Fixed Limits, then change this setting to Relative. Learn more [“Relative Limit Lines” on page 716](#).
    - **Upper/Lower** – Press **Edit** to toggle between the following:

- **Upper** - (Default) FAILS any measured data point **ABOVE** the line.
- **Lower** - FAILS any measured data point **BELOW** the line.
- **Off/On** – Press **Edit** to toggle between the following:
  - **On** - Limit line is drawn on the screen and PASS/FAIL testing occurs.
  - **Off** - Limit line is NOT drawn on the screen and testing does NOT occur.
- **Frequency** – Enter a numeric X-axis value of the data point.
- **Amplitude** – Enter a numeric Y-axis value of the data point.
- Press **Add** then choose from the following:
  - **Add Point** – Adds a blank X/Y data point below the cursor.
  - **Add Limit** – Adds a default limit line below the current limit.
- Press **Clear** then choose from the following:
  - **Clear Point** – Removes the X/Y data point on which the cursor resides.
  - **Clear Limit** – Removes the limit Line on which the cursor resides.
  - **Clear All** – Removes ALL limit lines.
- Press **<Back** to return to the Limit menu.

## Relative Limit Lines

Relative limit lines are X/Y coordinates that are referenced to the center frequency (X-axis) and acquisition (Y-axis).

Use relative limits to test devices or signals that are identical except for the center frequency or amplitude. With relative limit lines in place, you change the center frequency of the measurement and the limits look as though they are in the same location.

The same is true for acquisition. When you expect to measure a different power level, instead of changing the Y-axis value of all of the fixed limits, simply change to relative limits. The limits will then remain a constant Y-axis distance from the acquisition.

Each limit line can be changed at any time from Fixed to Relative, and Relative to Fixed.

## How to Create a Relative Limit Line

The easiest way to create a Relative limit line is to create a Fixed Limit at a specific center frequency and acquisition. Learn how **“Relative Limit Lines” on page 716**. Then change the limit line to Relative. The X/Y data points will be re-calculated relative to the center frequency and acquisition.

## Build From Trace

A limit line can be built from an existing trace. One X/Y point is made from each measured data point. Then, using an offset value, you can shift the limit line UP for upper limits or DOWN for lower limits.

Once limit lines have been built from the trace, changes that you make to the trace, such as frequency range, do NOT change the limits. However, the limit line properties can be edited just like standard limit lines.

Figure 29-7 A lower limit line (red) built from the trace (yellow) shifted down 5 dB.

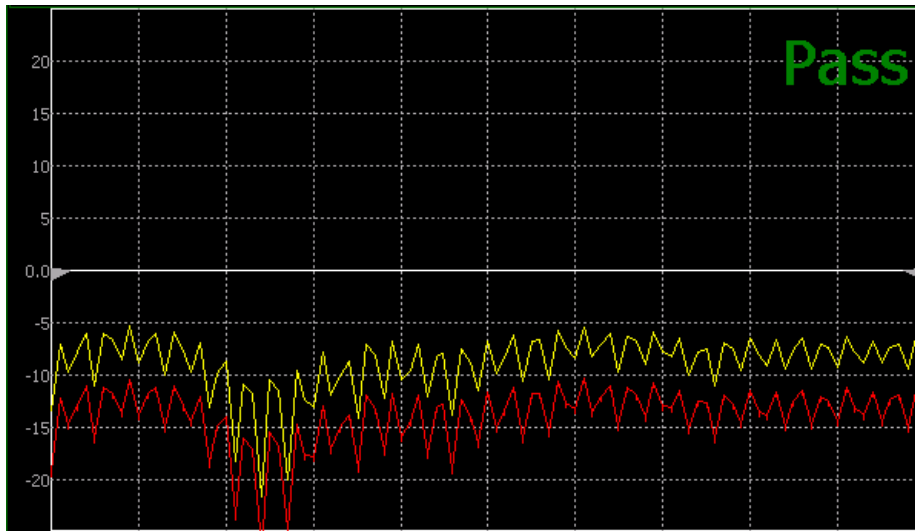

## How to Build Limit Lines from a Trace

### NOTE

Build from Trace is NOT allowed for traces with more than 1001 data points.

- Select the trace from which limits will be built.
- Press **Limit 8**.
- Then **Edit**.
- Then **Build From Trace**. A limit line table appears.
- Use the **▲▼** arrows to select ON.
- Use **Offset** to shift the limit line UP or DOWN. Learn how below.

## Limit Options

### How to set Limit Options

- Press **Exit** if the limit table is visible.
- Then **Options**.
- Then choose from the following:
  - **Beep**
    - **On Pass** Audible beep sounds when a sweep passes.

- **On Fail** Audible beep sounds when a sweep fails.
- **Off** No audible beep sounds.
- **Warning On Off** Shows Pass or **Fail** indication on the display with each sweep. Data points that fail are highlighted.
- **Limit Type** Then Fixed or Relative.
- **Offset** Shifts the limit line up or down. Enter an offset value using the rotary knob, the **▲▼** arrows, or by entering a value with the number keys.
  - Enter a **positive** offset to shift the limit line UP, usually used with UPPER limits.
  - Enter a **negative** offset to shift the limit line DOWN, usually used with LOWER limits.
- **Margin** Shifts the limit line up or down like an offset, but only virtually. The limit line does NOT appear to move. Enter a Margin value using the rotary knob, the **▲▼** arrows, or by entering a value with the number keys.
  - Enter a **positive** margin to virtually shift the limit line UP.
  - Enter a **negative** margin to virtually shift the limit line DOWN.

### How to Save and Recall Limits

- Press **Save/Recall** then **Device** to set the Device (Internal, SD card, or USB flash drive) to be used for the Save or Recall. Learn more in **“Set File Type and Select Device” on page 783**.
- Then press **Limit**.
- Then choose from the following:
  - **Save Limits** After limit lines have been defined, this saves the line definition to a file on the specified device.
  - **Recall Limits** Recalls a limit Line definition from the specified device.

## Display Line (I/Q, NF, and SA Modes Only)

A display line is a simple, horizontal line that can be placed at any amplitude level on the SA screen or set to any level in IQA. Use a display line as mental guide for visual feedback. A display line is similar to a Limit Line, except that no PASS/FAIL testing occurs. A display line is easier to create than a Limit Line. Learn more in [“All about Limit Lines” on page 715](#).

Figure 29-8 Display Line with Annotations (SA mode shown, but others are similar)

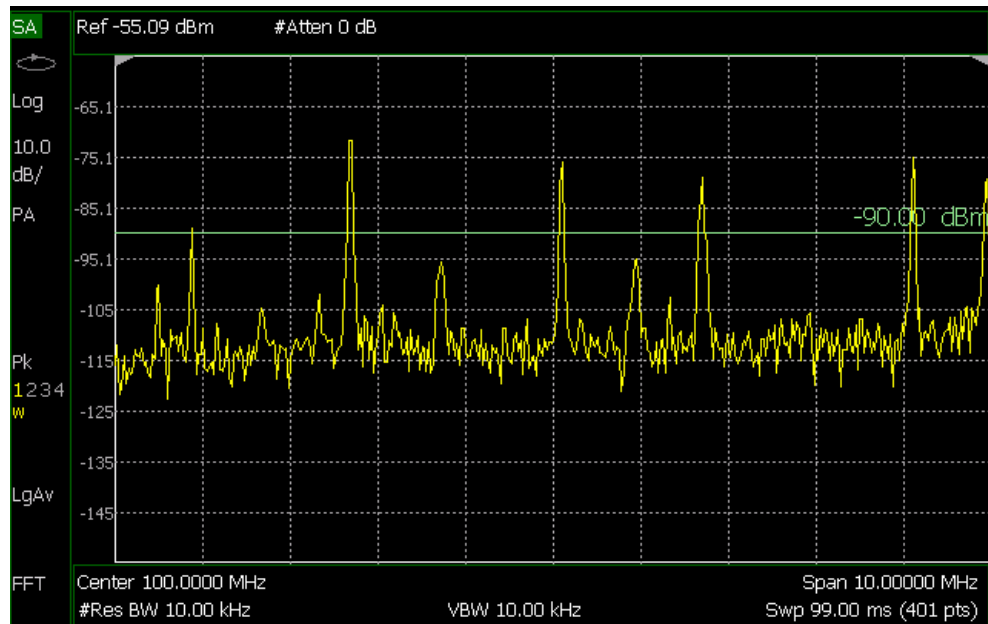

### How to create and move a Display Line

- Press **Limit 8**
- Then **Display Line OFF ON**
- Then enter a Y-axis value using the **▲▼** arrows or the rotary knob, then press **Enter**. Or enter a value using the numeric keypad and press a suffix key or press **Enter**.

## All about Trace Math

Trace Math is available in **CAT** (excluding DTF measurements), **NA** Mode, and FOPS (under USB Power Meter mode).

### NOTE

Noise Figure (NF–Opt. 356) does not have trace math, but does have the ability to display data and memory traces. Refer to “**How to display data and memory traces**”.

---

A trace is a series of measurement data points that are connected to form a line. This ‘live’ data trace is updated as data points are measured.

A memory trace is a live trace that has been stored in the FieldFox volatile memory. It then becomes static, meaning it is not updated with measurements. It can be displayed on the screen by itself, or with a data trace for comparison purposes.

- In NA mode, memory traces are the same color as data).
- In CAT mode and FOPS, the data trace is displayed in **yellow** and the memory trace is displayed in **blue**.

### How to display data and memory traces

- Press **Trace 6**.
- Press **Math and Memory** then **Data->Mem** to store the current live trace into memory. A ‘beep’ sounds to confirm the data trace has been saved to memory. There is no display annotation that indicates that the memory trace has been stored.
  - Press **Data** to view only the data trace.
  - Press **Memory** to view only the memory trace.
  - Press **Data & Memory** to view both the live trace and the stored memory trace.

### How to perform Trace Math

Trace math is performed between a live trace and a memory trace. When one of the following math operations are selected, the yellow data trace displays the current measurement with the selected trace math applied. The math operation symbol indicated below in [brackets] is displayed on the lower left corner of the screen.

- Press **Trace 6**.
- If not already stored, press **Data->Mem** to store the current live trace into memory.
- Then **Data Math**.
- Then choose one of the following:
  - **Data + Mem** [D+M] Current measurement data is added to the data in memory.
  - **Data – Mem** [D-M] Current measurement data is subtracted from the data in memory.

- **Data / Mem** [D/M] Current measurement data is divided by the data in memory.
- **Math Off** [Data] Displays trace data with NO math applied.

### About Math Operations

**Data / Memory** and **Data - Memory** math operations are performed on complex linear data before it is formatted. Because data is often viewed in log format, it is not always clear which of the two math operations should be used. Remember: dividing linear data is the same as subtracting logarithmic data. The following illustrates, in general, when to use each operation.

Use **Data / Memory** for normalization purposes, such as when comparing traces “before” and “after” a change is made or when measuring trace noise. In the following table, the Data/Mem values intuitively show the differences between traces. It is not obvious what Data-Mem is displaying.

Values to compare	Data/Mem	Data-Mem
0.5 dB and 0.6 dB	0.1 dB	-39 dB
0.5 dB and 0.7 dB	0.2 dB	-33 dB

Use **Data - Memory** to show the relative differences between two signals. Use for comparison of very small signals, such as the S11 match of two connectors.

In the following table, Data/Mem shows both pairs of connectors to have the same 2 dB difference. However, the second pair of connectors have much better S11 performance (-50 and -52). The relative significance is shown in **Data-Mem**.

Values to compare	Data/Mem	Data-Mem
-10 dB and -12 dB	2 dB	-24 dB
-50 dB and -52 dB	2 dB	-64 dB

## All about Scale Settings

### How to Use Scale Settings

Adjust the Y-axis scale to see the relevant portions of the data trace. The Y-axis is divided into 10 graticules.

This setting can be changed at any time without affecting calibration accuracy.

### How to set Scale

- Press **Scale / Amptd**.
- Then choose from the following three methods:
  1. **Autoscale** Automatically adjusts the Y-axis to comfortably fit the Minimum and Maximum amplitude of the trace on the screen.
  2. Set Scale, acquisition, and Reference Position:
    - **Scale** Manually enter a **scale per division** to view specific areas of the trace
    - **Ref Level** Manually set the value of the reference line. Enter a negative value by pressing **Run/Hold (+/-)** either before or after typing a value
    - **Ref Pos** Manually set the position of the reference line. Values must be between **0** (TOP line) and **10** (BOTTOM line)
  3. Set Top and Bottom graticule values. The scale per division is calculated.
    - **Top** to set the value of the Top graticule.
    - **Bottom** to set the value of the Bottom graticule.
    - Enter a negative value by pressing **Run/Hold (+/-)** either before or after typing a value.

#### Scale annotation on the FieldFox screen

Reference Line = red arrow

Ref Level = -40 dB

Ref Position = 1

Scale = 2 dB per division

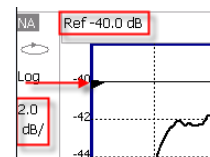

### Averaging (CAT, NA, Power Meter, Channel Scanner, and Pulse Measurement Modes Only)

Trace Averaging helps to smooth a trace to reduce the effects of random noise on a measurement. The FieldFox computes each data point based on the average of the same data point over several consecutive sweeps.

Average Count determines the number of sweeps to average; the higher the average count, the greater the amount of noise reduction.

An average counter is shown in the left edge of the screen as **Avg N**. This shows the number of previous sweeps that have been averaged together to form the current trace. When the counter reaches the specified count, then a 'running average' of the last **N** sweeps is displayed. Average Count = 1 means there is NO averaging.

This setting can be changed at any time without affecting calibration accuracy.

**NOTE**

Averaging is often used to increase the dynamic range of a measurement. To achieve the highest dynamic range, select NA mode and reduce the IF Bandwidth setting. Learn more about dynamic range in ["Increase Dynamic Range" on page 112](#).

---

### How to Enable/Disable Averaging

- Press **BW 2**.
- Then **Average OFF ON** change to ON to enable averaging (Default = OFF).
- Press **Enter**.
- Refer to ["How to set Trace Averaging" on page 723](#).

### How to set Trace Averaging

- Press **BW 2**.
- Then **Average N** where **N** is the current count setting.
- Enter a value using the numeric keypad. Enter 1 for NO averaging.
- Press **Enter**.
- While Trace Averaging is in process, press **Sweep 3** then **Restart** to restart the averaging at 1.

Data Analysis Features  
All about Scale Settings

## 9 System Settings

### In this Chapter

- “Run/Hold” on page 726
- “Preset” on page 727
- “User Preset” on page 727
- “Audio (Volume) Control” on page 728
- “Display (Settings)” on page 729
  - “Display Brightness” on page 729
  - “Display Colors” on page 729
  - “Trace Width” on page 730
  - “Title” on page 730
  - “Edit Keywords” on page 731
  - “Full Screen Mode” on page 731
- “Utilities” on page 732
  - “How to view and change Utilities Settings” on page 732
    - “Utilities Softkey Choices” on page 732
    - “How to view and change the Frequency Extender (Freq Extnd) Settings” on page 733
- “Preferences” on page 740
  - “Quick Settings Table” on page 740
  - “Save and Reset Preferences” on page 742
  - “Global Settings (Overview)” on page 742
    - “Language” on page 743
    - “Battery Saver” on page 743
    - “Startup Mode” on page 744
  - “File folders” on page 748
  - “Alpha Numeric Editing” on page 749

- “File Saving Naming Options” on page 749
- “System Configuration” on page 754
  - “Options (Licensing)” on page 754
  - “GNSS (GPS+) and GPS” on page 755
  - “Frequency Reference Source” on page 760
  - “Variable Voltage Source (Opt. 309)” on page 761
  - “Security Level” on page 762
  - “Date and Time, Format, and Time Zone Settings” on page 763
  - “LAN Settings” on page 764
  - “Power ON” on page 766
  - “FieldFox Package Installer” on page 767
  - “Date and Time, Format, and Time Zone Settings” on page 763
- “Service Diagnostics” on page 769
- “Understanding the Fan Controls” on page 771

**See Also:**



- “Install the Lithium-Ion Battery” on page 30
- “FieldFox High Temperature Protection” on page 32

## Run/Hold

The **Run/Hold** key determines whether the FieldFox sweeps continuously or does NOT sweep, but holds the display results of the last sweep that was performed.

Use **Hold** to conserve battery power or to allow you to save or analyze the results of a specific measurement sweep.

The current sweep mode is shown on the screen as:

-  Continuous
- Hold
-  is displayed while a single sweep occurs.

### How to perform a single sweep while in Hold

- Press **Sweep 3**.
- Then choose one of the following:

- **Single** Automatically sets Continuous OFF (Hold) and causes FieldFox to make ONE measurement sweep, then hold for the next Single key press.
- **SA Mode ONLY** – With **Continuous OFF** each successive **Run/Hold** press also causes a single sweep.
- **Continuous ON OFF** Makes continuous sweeps. This is the typical setting when battery power is not critical.

## Preset

The Preset key restores the FieldFox measurement settings to a known condition. You can preset the entire instrument, or just the current Mode (CAT, SA, and so forth).

When Preset, the FieldFox CalReady calibration is recalled for use in CAT and NA Modes. Learn more in [“CalReady” on page 127](#).

In addition to all **Preference** settings, the following settings always survive Preset and Mode Preset:

- External Reference state (see [“Frequency Reference Source” on page 760](#))
- SA Scale and Units (see [“Scale and Units” on page 157](#))
- SA Correction states (see [“Field Strength Measurements” on page 161](#))
- VVM Display Resolution (see [“Display Resolution” on page 588](#))
- Marker Peak Excursion and Threshold (see [“What Is a ‘Peak’” on page 711](#))

## How to Preset the FieldFox

- Press **Preset**.
- Then choose one of the following:
  - **Preset** Returns ALL Modes to the factory default settings.
  - **Mode Preset** Returns only the current Mode to the factory default settings. The current settings for all other Modes remain.

## User Preset

User Preset allows you to store custom settings for each mode, then recall the settings when the Preset key is pressed. Your custom settings are saved to a standard State file (UserPreset.sta). However, unlike State files, calibration data is NOT saved. Learn more about State files in [“Set File Type and Select Device” on page 783](#).

## How to set User Preset

- Make your custom settings for all modes.
- When finished, press **Preset**.
- Then **Save User Preset**, then select **Yes** to confirm.
- Then **User Preset ON**

## How to recall User Preset

- Press **Preset**.
- Then choose from the following:
  - **Preset (User)** The entire UserPreset.sta file is recalled. ALL modes assume the settings that were in place when the User Preset was saved. The active mode is the mode that was visible when the file was saved.
  - **Mode Preset (User)** The settings for only the current mode are recalled from UserPreset.sta.

### NOTE

- Only the instrument settings are saved to UserPreset.sta. No trace data or calibration data is saved.
- User Preset ON / OFF is saved as a Preference setting. Like all preferences, this setting survives a FieldFox shut down and power ON. Therefore, when User Preset is ON during shut down, the FieldFox will load UserPreset.sta when it is powered ON.
- To return to Factory Preset, select **User Preset OFF**. The contents of UserPreset.sta remain stored on the FieldFox. When User Preset is OFF, you can also set the Startup Mode preference that determines which mode will be visible after powering ON. Learn more in [“Startup Mode” on page 744](#).

## Audio (Volume) Control

System volume control is a FieldFox global setting which sets speaker volume for ALL success beeps, key press clicks, and individual features that use the FieldFox speaker, such as SA Mode Tune and Listen.

The volume control setting remains through a FieldFox Preset. To cause your volume control setting to remain through a FieldFox shut down, save the setting as a Preference. Learn how in [“Save and Reset Preferences” on page 742](#).

## How to set the FieldFox Volume Control

- Press **System 7**
- Then **Volume**
- Then use the  arrows, the rotary knob, or numeric keypad to enter a value between 0 (lowest volume) and 100 (highest volume).
- Press **Volume** again and select Mute to quickly turn OFF the speaker volume.
- Press **Volume** again to set volume ON to the previous volume control.

## Display (Settings)

You can adjust the FieldFox for optimum viewing in a wide range of lighting conditions.

Display settings are persistent after a FieldFox shut down. Save the display settings as Preferences. Learn how in [“Save and Reset Preferences” on page 742](#).

### NOTE

Clean the transfective screen with gentle and minimal wiping using Isopropyl alcohol applied to a lint-free cloth.

---

## Display Brightness

Change the brightness of the background.

### How to set Display Brightness

- Press **System 7**
- Then **Display**
- Then **Brightness**
- Use the  arrows, the rotary knob, or numeric keypad to enter a value between 0 and 100%.

## Display Colors

Change Display Colors to alter the viewing scheme.

### How to set Display Colors

- Press **System 7**
- Then **Display**

System Settings  
Display (Settings)

- Then **Display Colors**
- Then choose one of the following:

**Indoor**



**Outdoor Dusk**



**Outdoor Clouds**



**Outdoor Sun**



**Night Vision**



## Trace Width

You can set width of all displayed traces on the FieldFox. This may allow better viewing or enhance the look of screen images. This setting can be saved with Preferences.

### How to set Trace Width

- Press **System 7**
- Then **Display**
- Then **Display Colors**
- Then **More**
- Then **Trace Width**
- Then choose one of the following:
  - **Normal** - Standard width.Wide
  - **Wide** - Enhanced width

## Title

A custom title can be made to appear in the upper-left corner of the FieldFox screen. The title can contain up to approximately 65 alpha-numeric characters. To view the Title area, see the Screen Tour in **“Screen Tour” on page 44**.

### How to add or edit a Title

- Press **System 7**
- Then **Display**
- Then **Title**
- Then enter or edit a title using the FieldFox labeler. This is the same labeler function that is used to name files. Learn how to use the labeler in [“How to use the FieldFox labeler ” on page 780.](#)
- Then **Title ON OFF** to make the title appear and disappear from the screen.

### Edit Keywords

During a file save operation, keywords can be quickly appended to other text to create unique filenames. The Edit Keywords feature allows you to create custom keywords. Learn all about Edit Keywords in [“Edit Keywords” on page 789.](#)

### Full Screen Mode

Full Screen Mode maximizes the display of trace. The screen annotations and the soft keys are removed.

- Press **System 7**
- Then **Full Screen**

To **Exit** full screen Mode, press any key.

## Utilities

FieldFox utilities settings will not survive a shut down. When your FieldFox is turned OFF, then back ON, these settings default to their factory settings.

### NOTE

For information on the **Phase Array Antenna** and **USB antennas** softkeys, refer to [Chapter 14, “5G Rapid Prototype Phased Array Antenna – Option 360.”](#) and “USB Antennas” an [Chapter 15](#).

---

### How to view and change Utilities Settings

- Press **System 7**
- Then **Utilities** Opens the Utilities softkey menu.

### Utilities Softkey Choices

Then choose one of the following:

- **Mapping** – (Requires Option 352) opens a menu of softkeys that enables the Indoor / Outdoor on-the-box mapping features. Refer to [Chapter 16, “Indoor and Outdoor Mapping – Option 352 \(Requires Spectrum Analyzer Mode \(Option 233\), and GPS Receiver \(Option 307\)\).”](#)
- **Phased Array Antenna** (PAA – Requires Option 360) – opens a menu of softkeys that enables the PAA measurements. Refer to [Chapter 14, “5G Rapid Prototype Phased Array Antenna – Option 360.”](#)
- **USB Antennas** – opens a menu of softkeys that enables the triaxial antenna feature, for use in EMF measurements. Refer to [Chapter 15, “USB Antennas – \(Full Capability Requires EMF Option 358, and either SA mode \(Option 233 Mixed Analyzers\) or OTA–5G NR / 5G NR EVM Conducted Option 378\).”](#)
- **Freq Extnd** – opens a menu of softkeys that enables frequency extender feature, for use with OML heads. Refer to [“How to view and change the Frequency Extender \(Freq Extnd\) Settings” on page 733](#).

### NOTE

#### IMPORTANT!

The Frequency Extender (Freq Extnd) is only active (available) when one of the following modes are enabled: SA/RTSA/IQA/OTA/PAA/VSA (via the Remote Server feature).

When OML millimeterwave extenders are used, Cable and Antenna corrections, if On, are included in eCorr, or Extended Corrections.

---

## How to view and change the Frequency Extender (Freq Extnd) Settings

The following are the only supported modes for the frequency extender feature: SA (Option 233), mixed analyzers, RTSA (Option 350), IQA (Option 351), OTA (Option 370/377/378), PAA (Option 360) modes, and VSA (via the Remote Server feature).

### CAUTION

#### IMPORTANT!

Due to limitations in the OML hardware, the heads have a 6 GHz frequency span.

#### Examples

Using a 24 to 40 GHz mixer, you can sweep:

- 24 to 30 GHz and 25 to 31 GHz, but not
- 24 to 31 GHz

Assuming the same 24 to 40 GHz mixer, using OTA mode, you can

- Set a CCO to 24 GHz and CC1 to 31 GHz, but not
- CCO to 4 GHz and CC1 to 32 GHz, because you have to remain within the mixer's band

### CAUTION

PAA and 89600 VSA (via the Remote Server feature) are compatible with the frequency converter heads, but cannot apply or edit the frequency head corrections.

For this section, refer to [Figure 30-1 on page 737](#), [Figure 30-2 on page 738](#), [Figure 30-3 on page 738](#), [Figure 30-4 on page 739](#), [Figure 30-5 on page 739](#), and [Figure 30-6 on page 740](#).

These settings are used to set up a frequency extender head (e.g., OML head). The frequency extender feature can be used in OTA FR2 measurements. See also, [Chapter 13, “Over-the-Air Measurements \(OTA\) – LTE FDD Option 370, LTE TDD Option 371, 5G TF Option 377, 5G NR / 5G NR EVM Conducted Option 378.”](#)

The frequency extender heads are an external down converter that extends the FieldFox's range. The frequency extender head makes use of the FieldFox's source and uses USB port for power. The FieldFox support for the frequency extender head includes:

- The frequency extender heads are compatible with to SA, IQA, OTA, PAA, RTSA, and 89600 VSA (via the Remote Server feature—with VSA license).

### CAUTION

PAA and 89600 VSA (via the Remote Server feature) is compatible with the frequency converter heads, but cannot apply or edit the frequency head corrections.

**CAUTION**

The OML frequency extenders have approximately 4 to 10 dB of gain depending on the mixer and frequency.

---

- The USB ports are used to supply power to the head
- Port 1 is used to supply an LO signal to the head. The LO signal is automatically generated, using the internal source. Therefore the application disables normal Port 1 access to the internal source. But, automatic alignments of the SA Receiver still remain active using an internal path for the source.
- Port 2 is where the head delivers the downconverted signal to the SA receiver.
- High Sensitivity ON OFF selection: able to choose between showing largest span (wide) available (6 GHz) or best noise floor (narrow).

## Frequency Extender Procedure:

### General Comment on Frequency Converter Usage:

OML heads are limited to 6 GHz span.

Example:



If you are using a 24–40 GHz OML head you can sweep:

24–30 GHz and 25–31 GHz, but not:

24–31 GHz

But, in OTA mode, because each frequency is set separately, you can set CC0 to 24 GHz and CC1 to 31 GHz.

But, you cannot set CC0 to 4 GHz and CC1 to 32 GHz. You have to stay within the band of the OML mixer (24–40 in this example), if you are enabling an external head.

1. Press **System 7** > **Utilities** > **Freq Extnd** > **Select Freq Extnd Head** then
2. To select the frequency extender head, use the numeric keypad,   arrows, or rotary knob to change the value.
3. Press **Recall File** to make the highlighted head the current selection.
4. Press **Freq Extnd ON OFF** to **ON** to enable the frequency extender head. When a compatible mode is enabled, all supported modes annotate **Freq Extnd** at the bottom of the display. See also, step 8.
5. **Optional:** Press **High Sensitivity ON OFF** OFF is selected for maximum span (up to 6 GHz). Narrow is selected for lowest noise floor for a given RF input (100 MHz). Default is OFF (maximum span – 6 GHz).
6. **Optional:** Press **Setup Corr Auto Edit SA** when Auto is selected the default corrections for a frequency converter head are automatically loaded ("**...Default.csv**"). These corrections are defaults for the specific head, to improve nominal accuracy of the amplitude readings, but this accuracy is not specified. Press **Edit SA**, when you want to view or edit the corrections using the SA mode corrections. This state stops all auto-loading of the default corrections. Refer to step 8.

The other non-SA supported modes do not allow viewing or editing of the corrections, but they all share the same corrections.

Therefore, any manual changes to the corrections (using SA via Edit SA) are then used by other supported modes (RTSA/IQA/OTA) as well.

7. **Optional:** Press **Apply Corr ON OFF** OFF is selected to not apply the default nominal file corrections. Press to apply corrections for the Converter, all supported modes will apply corrections and annotate "**eCorr**" in the left

panel. The corrections applied (regardless of mode) are either default/nominal (if Auto loading was used) or custom/specific (if manual editing Edit SA was used). Default is OFF.

8. Press **Mode** > and then your preferred mode for testing.

**NOTE**

**IMPORTANT!** The softkey menu for editing of the frequency converter correction files is only available when the FieldFox is in SA mode.

- Optional: If you pressed **Edit SA** in step 6 above and want to display and to edit a "\*.csv" corrections file then:

- Press **Scale/Amptd** > **More** > **Corrections** > **OML Converter** then:

- a. **Converter** to enable/disable the frequency converter corrections.
- b. **Edit Converter** to opens a corrections table of the currently selected file (\*.csv).

To select a setting/value to edit, use the numeric keypad, **▲▼** arrows, or rotary knob to change the value.

Refer to [Figure 30-4 on page 739](#).

**CAUTION**

It is important to save any changes that are made to the Settings table. If the Setup Corr softkey is reset to Auto, it will recall the last "...Default.csv" used, and any unsaved changes will be lost.

- c. **New** to opens a corrections table of the currently selected file (\*.csv), but enables you to create a new converter corrections file. Displays "Overwrite existing Converter data?" Then choose:

- Yes** to clear all of the frequency converter correction table's values and enter your own.

- No** to leave the current correction table values and edit just some of the entries.

To select a setting/value to edit, use the numeric keypad, **▲▼** arrows, or rotary knob to change the value.

Refer to [Figure 30-4 on page 739](#).

- d. **Save Converter** opens a 'labeler' menu where you can name and save your frequency converter corrections file (\*.csv) to the default [ INTERNAL ] : \Converter folder.
  - e. **Recall Converter** opens a menu where you can recall a frequency converter corrections file (\*.csv).
- Storage Device** opens a menu where you can change the storage location of your frequency converter correction files (\*.csv). (Default = Internal. Else, SD Card or USB.)

See also, Chapter 13, "Over-the-Air Measurements (OTA) – LTE FDD Option 370, LTE TDD Option 371, 5G TF Option 377, 5G NR / 5G NR EVM Conducted Option 378."

Figure 30-1 FieldFox with OML Downconverter



Figure 30-2 FieldFox Frequency Converter High Sensitivity (ON: Narrow—Lowest Noise Floor—Displayed)

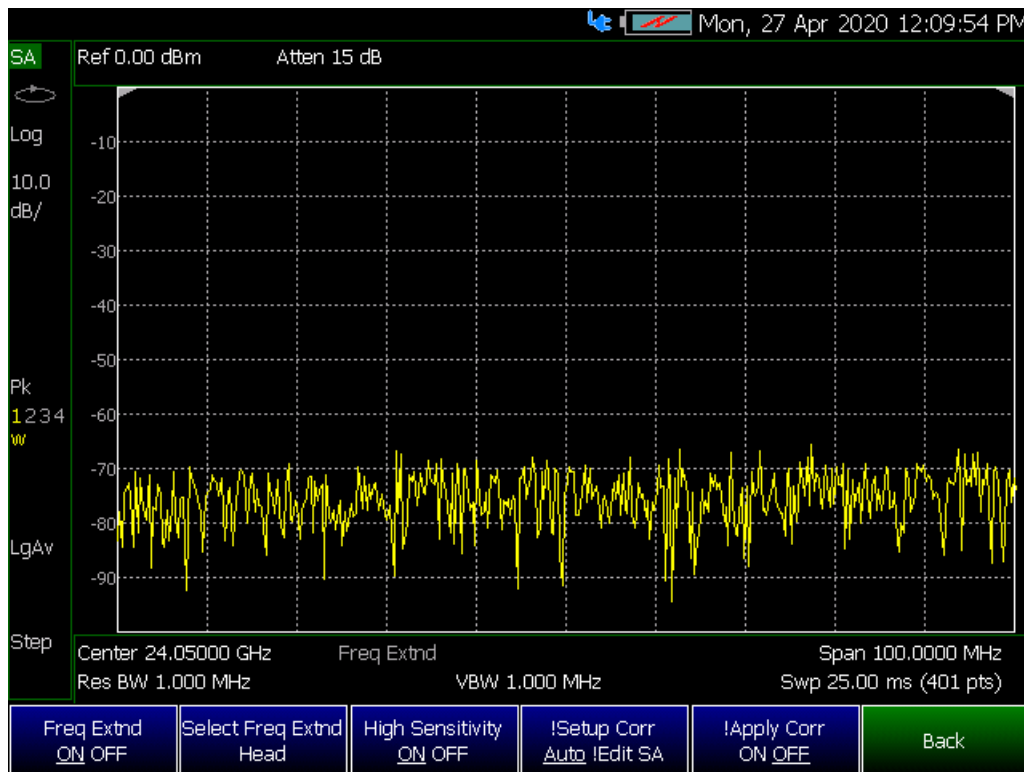

Figure 30-3 FieldFox Frequency Extender Select Frequency Extender Head

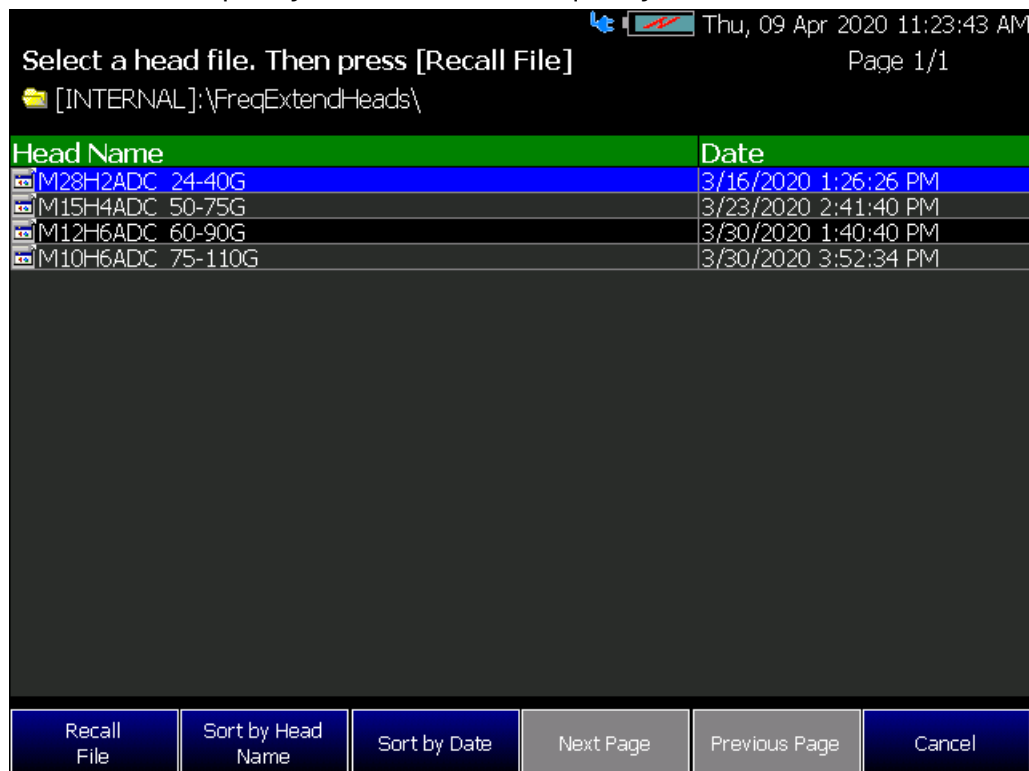

Figure 30-4 FieldFox Frequency Converter Corrections Table

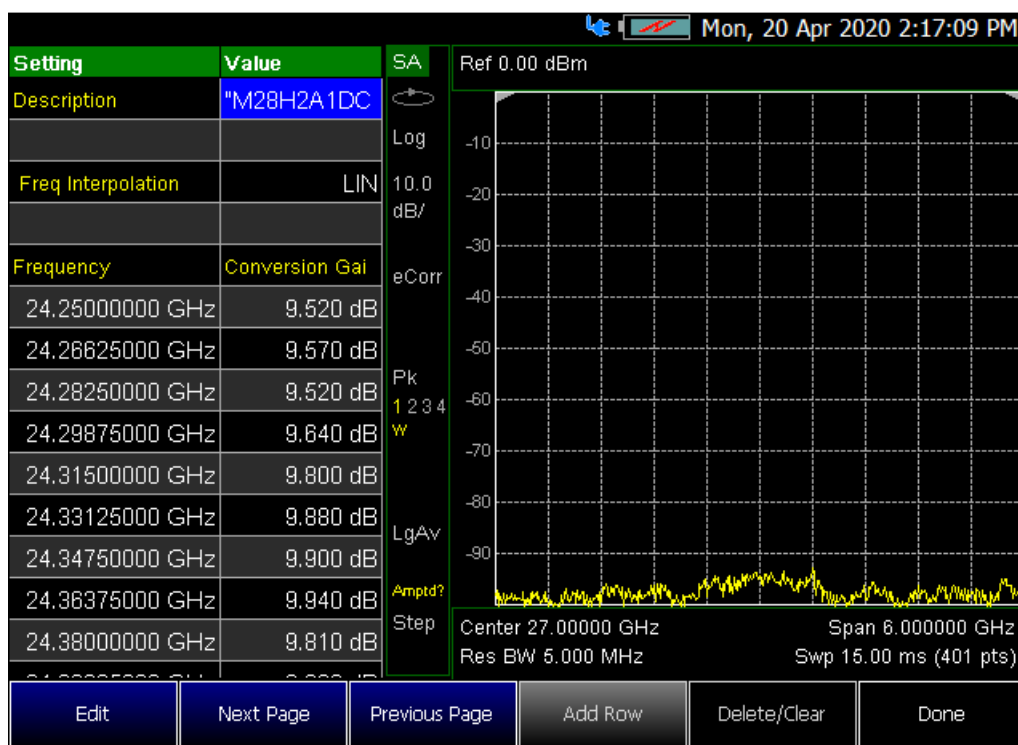
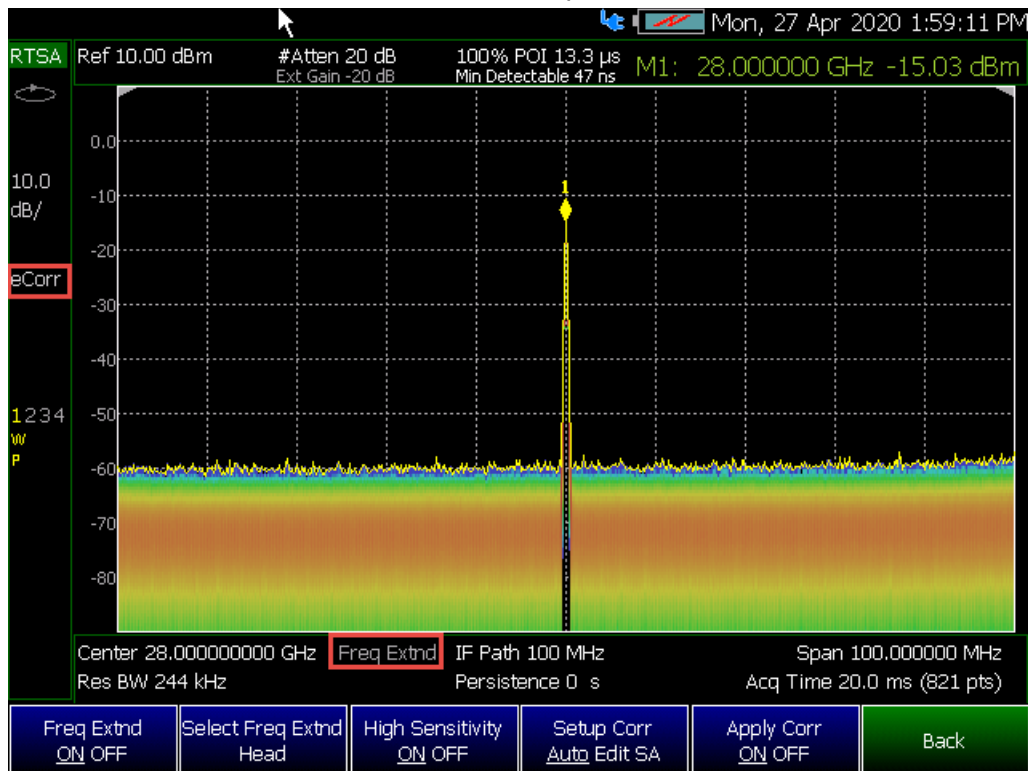

Figure 30-5 FieldFox Frequency Converter (Freq Extend) On And Corrections (eCorr) Enabled (SA mode shown; other compatible modes are similar.)



Figure 30-6

FieldFox Frequency Converter (Freq Extend) On And Corrections (eCorr) Enabled (RTSA mode shown; other compatible modes are similar.)



## Preferences

FieldFox preferences are settings that survive a shut down. When your FieldFox is turned OFF, then back ON, these settings remain. All preference settings can be restored to their factory defaults. Learn how in [“Save and Reset Preferences” on page 742](#).

There are two ways to make FieldFox preference settings:

- From softkey selections throughout the FieldFox menu structure. Do this to temporarily try a setting, then press [Save Current Preferences](#). Learn how in the next section.
- From the Quick Settings table.
- Also, refer to: [“Audio \(Volume\) Control” on page 728](#) and [“Display \(Settings\)” on page 729](#).

## Quick Settings Table

All preferences can be set from the Quick Settings table. They are immediately saved as Preferences when [Done](#) is pressed.

## How to view and change Preference Quick Settings

- Press **System 7**
  - Then **Preferences**
  - Then **Preferences**
  - Press **Next Page** and **Previous Page** to view all settings.
  - To change a setting:
    - Use the **▲▼** arrows to highlight a setting.
    - Then press **Edit**. The current setting changes to **yellow**.
    - Some settings require you to press a softkey to change the value. Otherwise, use the numeric keypad, **▲▼** arrows, or rotary knob to change the value.
    - When finished changing a value, press **Done Edit**.
  - When finished changing ALL preferences, press **Done**. All changes are immediately saved as Preferences.
  - To exit the editing session without saving changes, press **Esc** at any time.
- Learn more about these preference settings:

### Settings

**“Global Settings (Overview)” on page 742**

- **“Language” on page 743**
- **“Battery Saver” on page 743**
- **“Startup Mode” on page 744**

**“Display (Settings)” on page 729**

**“Audio (Volume) Control” on page 728 and “Audio” on page 745**

**“Date and Time” on page 746**

**“GNSS (GPS+) and GPS” on page 755**

**“Frequency Reference Source” on page 760**

**“File folders” on page 748**

**“Alpha Numeric Editing” on page 749 (i.e., ABC/Qwerty keyboard styles)**

**“File Saving Naming Options” on page 749**

**“Quick Save Editing” on page 749**

**“Group Save File Types Editing” on page 750**

## Settings

“CAT (Distance Units)” on page 751

“CAT/NA” on page 752

“SA” on page 753

“Discrete Colors Softkey Menu” on page 754 - Part of Preferences softkey menu.

## Save and Reset Preferences

All preference settings can be made at one time from the Quick Settings table.

All settings that can be saved as preferences (except Battery Saver and Startup Mode) can also be made from individual softkey selections throughout the FieldFox menu structure. However, they remain through a FieldFox shut down ONLY when the current settings are saved as preferences.

The table above shows a list of all of these settings and where they are discussed in this User’s Guide.

### How to save current settings as Preferences

- Using softkeys, configure the settings as you would like them to remain.
- Press **System 7**
- Then **Preferences**
- Then **Save Current Settings** There is a beep when your settings have been saved.
- Press **Reset Preferences** to restore the factory default settings.

## Global Settings (Overview)

Choose the Global Settings values (Language, Batter Saver, and Startup Mode). See also “**Quick Settings Table**” on page 740.

### How to select Global Settings:

- Press **System 7**
- Then **Preferences**
- Then **Preferences**
- Then use arrow softkeys or the knob to select Global Settings
- Then **Edit** for each of the following:
  - Language (see)
  - Batter Save Mode (see)

System Settings  
Preferences

- On
- Off (default)
- Startup Mode (see)
- Then **Done Edit** (for each change in setting)

## Language

Choose the language in which to display FieldFox softkeys and other messages. Select Save Current Settings to set this language as a preference.

### How to select a Language

- Press **System 7**
- Then **Preferences**
- Then **Language**
- Then choose from the following:
  - **English**
  - **Espanol – Spanish**
  - **Deutsch – German**
  - **Italiano – Italian**
  - **Francais – French**
  - **Russian**
  - **Japanese**
  - **Chinese**
  - **Turkish**

## Battery Saver

When the battery saver is OFF, the RF source power is left ON at the end of the sweep which consumes more battery power. This feature is used in CAT, NA, VVM modes, and SA mode when the internal source is turned ON.

Battery Saver is the ONLY FieldFox setting that must be made as a Preference from the Quick Settings table. This setting remains until you change it again.

### NOTE

The FieldFox internal temps will run 2°C – 5°C cooler with the Battery Saver on (the temperature range is dependent on the ambient temp).

### How to set Battery Saver

- Press **System 7**

System Settings  
Display

- Then **Preferences**
- Then **Preferences**
- Then scroll to **Global Settings > Battery Saver**
  - **ON** – To conserve battery power, the RF source power is turned OFF at the end of each CAT, NA, and VVM mode sweep. This behavior does not impact FieldFox measurements.
  - **OFF** – Source power is kept ON at all times, including during trigger Hold mode and between single sweep acquisitions. The RF source stays at the stop frequency until another sweep begins. This provides a constant, uninterrupted RF output from the RF OUT port. This behavior also provides the highest trace stability sweep-to-sweep which may only be evident while using either single sweep or Run/Hold. With Battery Saver OFF, the use of a full battery charge is reduced by approximately 45 minutes.

## Startup Mode

The Startup Mode setting determines the mode that becomes active (visible) when User Preset is set to OFF (Factory Preset) and the FieldFox is powered ON. See [“User Preset” on page 727](#).

### How to setup Startup Mode

- Press **System 7**
- Then **Preferences**
- Then **Preferences**
- Then scroll to **Global Settings > Startup Mode** and press **Edit**.
- Then repeatedly press the **Startup Mode** to scroll through the available choices.
  - **<Default>** is the factory default mode for your FieldFox model.
  - Built-in Power Meter Mode is NOT allowed as a Startup Mode.

## Display

Choose the Display values (Display Colors, Trace Width, Brightness, Title Enabled, Title). See [“Display \(Settings\)” on page 729](#).

How to select Display values:

- Press **System 7**
- Then **Preferences**
- Then **Preferences**

System Settings  
Audio

- Then use arrow softkeys or the knob to select **Display**
- Then **Edit** for each of the following:
  - Display Colors
  - Indoor (default)
  - Night Vision
  - Outdoor Sun
  - Outdoor Dusk
  - Outdoor Clouds
- Trace Width
  - Normal (default)
  - Wide

**NOTE**

Setting trace width to **Wide**, will result in slower trace refresh rates.

---

- Brightness
  - 0 to 100% (80% default)
- Title Enabled
  - On
  - Off (default)
- Title
  - User Title (default)
- Then **Done Edit** (for each change in setting)

## Audio

Choose the Audio values (Mute, Volume). See also **“Audio (Volume) Control” on page 728**.

How to select Audio values:

- Press **System 7**
- Then **Preferences**
- Then **Preferences**
- Then use arrow softkeys or the knob to select **Audio**
- Then **Edit** for each of the following:

System Settings  
Date and Time

- Mute
  - On
  - Off (default)
- Volume
  - 0 to 100 (default is 50)
- Then **Done Edit** (for each change in setting)

## Date and Time

Choose the Date and Time values (Date and Time, Time Format, Date Format, and Time Zone). See also **“Date and Time, Format, and Time Zone Settings” on page 763.**

How to select CAT distance units:

- Press **System 7**
- Then **Preferences**
- Then **Preferences**
- Then use arrow softkeys or the knob to select **Date and Time**
- Then **Edit** for each of the following:
  - Date and Time
    - Edit as needed (Refer to **“Date and Time, Format, and Time Zone Settings” on page 763**):
      - Time Format
      - Date Format
      - Time Zone
- Then **Done Edit** (for each change in setting)

## GPS

Choose the GPS values (GPS State, Elevation Unit, GPS Sync Clock, Display, Lat/Lon Format). See also **“GNSS (GPS+) and GPS” on page 755.**

How to select CAT distance units:

- Press System 7
- Then Preferences

System Settings  
GPS

- Then Preferences
- Then use arrow softkeys or the knob to select **GPS**
- Then Edit for each of the following:
  - GPS State
    - Off (default)
    - Internal
    - External
  - Elevation Unit
    - Meters (default)
    - Feet
    - Inches
  - GPS Sync Lock
    - Off (default)
    - Internal
    - External
  - Display
    - On
    - Off
  - Lat/Lon Format
    - ddd° mm' ss.sss"
    - ddd.ddddddd°
    - ddd° mm.mmmmm'
- Then Done Edit (for each change in setting)

## Frequency Reference

When Internal or External is selected, a search is made for satellites overhead. GPS (default) works best when outdoors and in full view of the open sky.

See also, “GNSS (GPS+) and GPS” on page 755.

How to set the frequency reference settings:

This procedure saves your frequency reference settings using the Quick Settings Table in Preferences. Learn more in “Quick Settings Table” on page 740.

1. Press **System 7** > **Preferences** > **Preferences** then
2. Press **Next Page** until **Frequency Reference** is displayed.
3. Use arrow keys **▲▼** or knob to scroll down to until **Frequency Ref Source** is highlighted.
4. Press **Edit** > **Frequency Ref Sou [GPS]** then
5. Choose from the following:
  - **GPS** - (default setting).
  - **External** - Enable GPS using an external, customer-supplied, USB dongle device. A check is made to detect a USB GPS device at the USB connectors.
  - **Internal** - Enable GPS using Option 307 – Built-in GPS. Connect a GPS antenna to the top-panel GPS connector. Learn more about additional GPS antenna accessories at <http://www.keysight.com/find/fieldfox>. Internal is set automatically when Frequency Reference Source is set to GPS. Learn more in “Frequency Reference Source” on page 760.

## File folders

When enabled, FieldFox uses the last selected Device and Folder location as the default device location after instrument power cycle.

### NOTE

Before setting the preferences for the File Folders, you must select the Device and Folder locations. Refer to **Chapter 32, “File Management.”**

How to set File Folders

- Press **System 7**

- Then **Preferences**
- Then **Preferences**
- Then scroll to User Folder Persist:
  - **User Folder Persist (On/Off)** – Defaults to the current Device and folder location at power up. Toggle User Folder Persist On/Off when a new Device location is selected location.
  - **User Folder** – displays the default folder location.
  - **User Device** – displays the default device location.

See also: “Alpha Numeric Editing” and “File Saving Naming Options”.

## Alpha Numeric Editing

- **Keyboard Style** – Toggles through Qwerty/ABC style keyboards that the Labeler displays. Refer to “How to use the FieldFox labeler ” on page 780.

## File Saving Naming Options

- **Prefix** – Displays the current choice for Prefix. Choices are User, Last File (default), or Off. Refer to Prefixes and Suffixes for Filenames in “Prefixes and Suffixes for Filenames” on page 789.
- **Auto Append** – Displays the current choice for Auto Append to a filename (Suffix). Choices are Off (default), Number, Date. Refer to “Prefixes and Suffixes for Filenames” on page 789.

## Quick Save Editing

Enables/disables the Quick Save feature. Quick Save saves any files you have set to On in the Group Save File Types preferences. Refer to “Group Save File Types Editing” on page 750.

To save the **User Device** storage location, refer to **Chapter 32, “File Management.”**

### CAUTION

#### IMPORTANT!

To avoid losing data, before using the Quick Save feature, verify that you have all of the correct data file types enabled for saving.

1. Press **System 7** > **Preferences** > **Preferences** then

2. Press **Next Page** until **Quick Save** is displayed.
3. Use arrow keys **▲▼** or knob to scroll down to until your choice is highlighted then choose one or more of the following:
  - **Save/Recall Long Press** – Enables/Disables the Quick Save feature. When enabled (default = Off), when the **Save/Recall 9 hardkey** is held down for ~3 seconds, the specified files are saved to a file with the FFoxData prefix. See also, Prefixes and Suffixes in **“Prefixes and Suffixes for Filenames” on page 789**.
  - **Quick Save Prefix** – Chooses the name of the Quick Save data file’s prefix. Press the **Edit** softkey to edit the prefix name in the "Quick Save Prefix" menu (default = FFoxData). Refer to **“Prefixes and Suffixes for Filenames” on page 789**.
  - **Quick Save Suffix** – Chooses the name of the Quick Save data file’s suffix. Press the **Edit** softkey to edit the suffix type Number or Data (default = Number). Refer to **“Prefixes and Suffixes for Filenames” on page 789**.

## Group Save File Types Editing

Enables/disables the selected file types to be saved as part of the Group Save File Types feature. (Default for all group save file types = Off.) Refer to **“Quick Save Editing” on page 749**.

### Group Save File Types Procedure

1. Press **System 7** > **Preferences** > **Preferences** then
2. Press **Next Page** until **Group Save File Types** is displayed.
3. Use arrow keys **▲▼** or knob to scroll down to until your choice is highlighted then:
4. Press **Edit** then
5. Press **'file type' Data (.xxx)** to enable/disable the data file type (default = Off). (e.g., **Image (.png) ON OFF**, **CSV Data (.csv) ON OFF**, etcetera).
6. Repeat steps 3 through 5 as required.
7. Press **Done Edit** to exit the current data type softkey menu.
8. Press **Done** to exit the Preferences menu and save your Preferences.

### Group Save File Types

- **State+Trace (.sta)** – Enables/Disables .sta as a group. file to be saved when the Quick Save (Save/Recall 9) hardkey is pressed for ~3 seconds.

System Settings  
CAT (Distance Units)

- **State (.sta)** – Enables/disables .sta files as a group file to be saved when the Quick Save (Save/Recall 9) hardkey is pressed for ~3 seconds.
- **Image (.png)** – Enables/disables .png files as a group file to be saved when the Quick Save (Save/Recall 9) hardkey is pressed for ~3 seconds.
- **CSV Data (.png)** – Enables/disables .csv data files as a part of the group files to be saved when the Quick Save (Save/Recall 9) hardkey is pressed for ~3 seconds.
- **S1P Data (.s1p)** – Enables/disables .s1p data files as a part of the group files to be saved when the Quick Save (Save/Recall 9) hardkey is pressed for ~3 seconds.
- **S2P Data (.s2p)** – Enables/disables .s2p data files as a part of the group files to be saved when the Quick Save (Save/Recall 9) hardkey is pressed for ~3 seconds.
- **Matalab Data (.mat)** – Enables/disables .mat data files as a part of the group files to be saved when the Quick Save (Save/Recall 9) hardkey is pressed for ~3 seconds.
- **SDF Data (.sdf)** – Enables/disables .sdf data files as a part of the group files to be saved when the Quick Save (Save/Recall 9) hardkey is pressed for ~3 seconds.

## CAT (Distance Units)

Choose the CAT distance units (i.e., Meters (default), Feet, Inches). See “**DTF Units**” on page 73.

How to select CAT distance units:

- Press **System 7**
- Then **Preferences**
- Then **Preferences**
- Then **Edit** for each of the following:
  - Distance Units:
    - Meters (default)
    - Feet
    - Inches
  - TDR Sweep:
    - Cable (default and the most accurate)
    - Auto
- Then **Done Edit** (after each change in setting)

## CAT/NA

Choose the CAT/NA settings for SnP file save, default factory error corrections, extended cal default. See also “> **What Data Processing functions are included in saved SNP Data:**” on page 785.

How to select CAT/NA defaults:

- Press **System 7**
- Then **Preferences**
- Then **Preferences**
- Then use arrow softkeys or the knob to select CAT/NA
- Then **Edit** for each of the following:
  - SnP File Save
    - Default
    - Advanced
  - Default Factory Error Corr. (N995xB/6xB Only)
    - Enhanced Response
    - Full 2 Port
  - Extended Cal Default (N995xB/6xB Only)
    - On
    - Off (default on models >6 GHz)
- Then **Done Edit** (after each change in setting)

## SA

Choose the SA setting for Individual measurement Control default. See also [“Alignments” on page 201](#).

How to select SA defaults:

- Press **System 7**
- Then **Preferences**
- Then **Preferences**
- Then use arrow softkeys or the knob to select SA
- Then **Edit** for each of the following:
  - **Individual measurement Control**
    - On (Default - recommended)
    - Off
  - **ADC Over Range Large Warning**
    - On
    - Off (Default)
- Then **Done Edit** (after changing setting)

## Discrete Colors Softkey Menu

The discrete colors softkey menu can be used to increase the choice of colors displayed from two to up to six colors, for easier measurement readings. Refer to [Figure 30-7](#).

Figure 30-7 Display Example: Color Coded Bar Scale (x6 Colors)



### Using the Discrete Colors Softkey Menu

1. Press **System 7** > **Preferences** > **Discrete Colors**
2. Choose from the following:
  - **Discrete Colors ON OFF** – to enable/disable the discrete colors greater than 2.
  - **Number of Colors** – choose up to 6 discrete colors (Minimum (default) = 2, red and blue).
  - **High Power Red Blue** – choose red or blue to choose the color to indicate the highest power levels (default = Red).

## System Configuration

### Options (Licensing)

You can view and install options on your FieldFox. To see a comprehensive list of the options that are available, view the FieldFox Configuration Guide at: <http://literature.cdn.keysight.com/litweb/pdf/5992-3701EN.pdf>

#### How to view the Installed Options

- Press **System 7**
- Then **System Configuration**
- Then **Options (Licensing)**
- Then **Show Options**

The currently installed options are listed.

#### How to Install Options

A.lic file must already be on a USB Flash Drive. To learn how to obtain a.lic file, visit: <http://www.keysight.com/find/softwarelicense>

Insert the USB Flash Drive in the FieldFox.

- Press **System 7**
- Then **System Configuration**
- Then **Options (Licensing)**
- Then **Install Options** The FieldFox reads, validates, then installs the options.
- Press and hold the power button to shut down, then restart the FieldFox.

### How to Delete ALL Options

Deleting individual options is NOT supported.

- Press **System 7**
- Then **System Configuration**
- Then **Options (Licensing)**
- Then **Advanced**
- Then **Delete All Options**

After a warning message, all options on the FieldFox are deleted.

#### NOTE

**Delete All CFG Options** is to be used by Service Personnel ONLY.

---

For more information about Licensing, see the FieldFox Service Manual at:  
<http://na.support.keysight.com/fieldfox>.

## GNSS (GPS+) and GPS

#### NOTE

**IMPORTANT!** The FieldFox may display "Ant OPEN", even when a GPS antenna is connected to the FieldFox. If the GPS antenna is powered by another power supply **and** has a DC blocking capacitor where the feed is connected to FieldFox, then minimal amounts of current will be drawn from the FieldFox, so the instrument will display "Ant OPEN". The threshold to detect the presence of an antenna is approximately 1.6 mA.

---

GPS (Global Positioning System) allows you to 'stamp' each data trace with your physical position in latitude/longitude/elevation format. This can be useful when making measurements on cell towers or other antennas at remote locations.

- **With Option 307**, GPS is available with the built-in receiver accessed through the top-panel SMA (f) connector. This connector has a settable 3.3 VDC or 5 VDC bias voltage which is switched ON when GPS is set to Internal. This system is designed for use with an active antenna such as the Keysight N9910X-825.

- **Without Option 307**, GPS is usable ONLY with an external GPS receiver that is shipped with Microsoft “Streets and Trips” and “AutoRoute”. The GPS receiver is NOT available from Keysight. Only the GPS USB receiver is used with the FieldFox. Therefore, it is NOT necessary to purchase the very latest version of the map software.

## How to make GPS settings

GPS settings are the same with, or without, Option 307.

- Your GPS settings can be saved with Preferences. Learn more in **“Quick Settings Table” on page 740**.
- Press **System 7**
- Then **System Configuration**
- Then **GPS** or **GNSS (GPS+)** – depending on options
- Then choose from the following:
- **Display ON OFF** Enable and disable the GPS display on the FieldFox main window.
- **GPS**
  - **OFF** - Disable GPS (default setting).
  - **External** - Enable GPS using an external, customer-supplied, USB dongle device. A check is made to detect a USB GPS device at the USB connectors.
  - **Internal** - Enable GPS using Option 307 – Built-in GPS. Connect a GPS antenna to the top-panel GPS connector. Learn more about additional GPS antenna accessories at <http://www.keysight.com/find/fieldfox>. Internal is set automatically when Frequency Reference Source is set to GPS. Learn more in **“Frequency Reference Source” on page 760**.

When Internal or External is selected, a search is made for satellites overhead. GPS works best when outdoors and in full view of the open sky. When several satellites are found, the following screen appears (when Display is set to ON) and is updated frequently:

### NOTE

As the bar graph count exceeds 9 bars, the “dB” text is dropped from the number displayed on the bar. Units for C/No are dBHz.

---

Figure 30-8

GPS Display

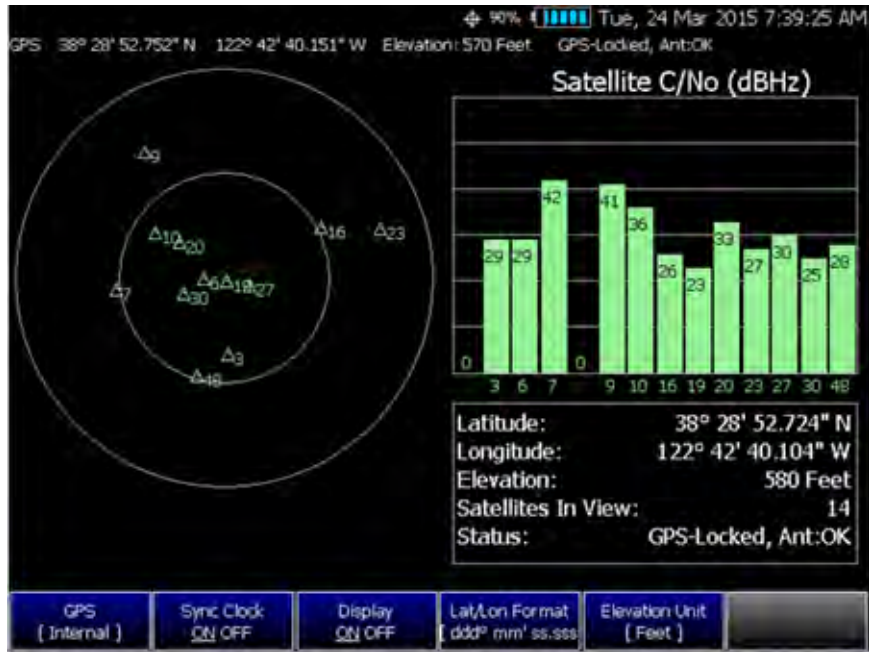

- The left portion of the screen displays satellites and the corresponding number on the adjacent Satellite Power chart.
- The right portion of the screen displays Satellite Power Carrier to Noise (C/No) dBHz values on the tops of the satellite power chart.

**NOTE**

The C/No values returned are not calibrated at the factory or warranted for accuracy. The numbers retrieved are passed unprocessed directly from the GPS receiver in use.

GPS Status

With GPS enabled the following is displayed at the top of the FieldFox screen:



The following icons (located in RED circle above) indicate the GPS lock status:

- GPS ON and locked on satellites.
- GPS ON, but NOT locked on satellites.
- GPS ON, but no GPS receiver is present or detected.

The following annotation (BLUE circle in above image) indicates the **INTERNAL**, top-panel antenna status:

- Ant: **INIT** – antenna status initializing.

- Ant: **OK** – antenna present and working.
- Ant: **OPEN** – antenna is not drawing DC bias current. This could occur when an active antenna is not connected properly or the antenna does not require DC bias current. Antennas that do not require bias current can still provide an accurate GPS reading.
- Ant: **SHORT** – antenna center pin has been shorted to ground. The internal bias circuitry is disabled for about one minute, then re-enabled. You can also press **GPS OFF**, then **GPS Internal** to quickly re-enable the antenna bias.

### More GNSS and GPS settings

See also, “**GNSS and GPS Freq Ref Source Settings**” on page 760.

- Press **System 7**
- Then **System Configuration**
- Then **GNSS (GPS+)** or **GPS** (depending on options) > **GNSS Settings**
- Then choose from the following:
- Enable and disable the synchronization of the FieldFox internal clock to the GPS UTC time standard.

#### NOTE

The GPS Sync setting has the same restrictions as the Date and Time setting. Learn more in “**Date and Time**” on page 746.

- **ON** The FieldFox clock is synchronized and updated approximately once every hour to the time of the GPS clock.
- **OFF** The FieldFox clock is NOT synchronized with GPS. When set to OFF after Sync was ON, the date and time does NOT revert back to the settings before the clock was synchronized.
- **Display ON OFF** Enables or disables displaying Lat/Lon Format and Elevation Units.
- **Lat/Lon Format** Change the format of the GPS display on the FieldFox screen. Choose from:
  - **ddd°mm’ ss.sss”** degrees, minutes, seconds (default setting)
  - **ddd°mm.mmmmm’** degrees, minutes, fractional minutes
  - **ddd.dddddd°** decimal degrees
- **None** Lat/Lon is not displayed.
- **Elevation Unit** Choose from:
  - **m** (Meters)
  - **Feet**

- **Inches**
- **Antenna Voltage** Choose from:
  - **3.3V 5V** – Settable to: 3.5 VDC or 5 VDC. When the bias voltage is set to ON and when the GPS is set to Internal. This system was designed for an active antenna such as the Keysight N9910X-825

### Saving Data with GPS Enabled

GPS position and clock data are included when data is saved with the following files types: \*.csv, \*.SnP, State, State+Trace data save.

A warning is shown if the GPS is ON but unlocked at time of save, or if the GPS feature is ON but no GPS is physically present at time of save.

The following is a sample S1P file with GPS information:

```
!GPS Latitude: 38 28.87717 N
!GPS Longitude: 122 42.66625 W
!GPS TimeStamp: 06/25/2010 16:24:48
!GPS Seconds Since Last Read: 2s
```

### Saving GPS Display Data

To save the current GPS data displayed:

- Press **Save/Recall 9**
- Then **Save File Picture (PNG)**
- A menu opens to enable naming the file you are saving (\*.png).

### More GNSS Settings

- Press **System 7**
- Then **System Configuration**
- Then **GNSS Selection**
- Then choose from the following:
  - **GPS** Refer to **“How to make GPS settings” on page 756.**
  - **GLONASS** Global navigation system, operating as part of a radio navigation-satellite system. Learn more **“More GNSS and GPS settings” on page 758.**
  - **BDS** - China’s BeiDou navigation system. Learn more **“More GNSS and GPS settings” on page 758.**
  - **GALILEO** - European navigation system. Learn more **“More GNSS and GPS settings” on page 758.**

## GNSS and GPS Freq Ref Source Settings

For convenience, the GNSS Settings menu includes the **Freq Ref Source** softkey.

- Press **System** > **System Configuration** > **GNSS (GPS+)** > **Freq Ref Source** > **GPS** then
- Choose one of the following:
  - **Int**, **Ext**, or **GPS**

For more, on the **Freq Ref Source** softkey choices, refer to “**Frequency Reference Source**” on page 760.

## Frequency Reference Source

The FieldFox internal frequency reference source is used to make accurate and stable measurements. To improve measurement accuracy and stability, you can use a highly-stable external 10 MHz reference source or a precision timing signal provided with Built-in GPS (Opt. 307).

The Frequency Reference setting will survive a Factory Preset or Mode Preset and is saved as part of the Instrument State. When resuming after Standby, the FieldFox will display an Unlock message while it acquires a lock to an external or GPS source.

## How to select Frequency Reference Source

- Press **System 7** > **System Configuration** > **Frequency Ref** > **Freq Ref Source**
- Then choose from the following:
  - **Int** Internal frequency reference
  - **Ext** External frequency reference. Connect the 10 MHz External Reference to the **Ref In/Trig In** SMA (f) connector on the FieldFox top panel. The FieldFox may take up to 10 seconds to lock to a valid External Reference source
  - **GPS** Available ONLY with Built-in GPS (Opt. 307). When selected, the internal GPS is immediately enabled and a search for satellites begins. When satellites are found, the precision timing signal is NOT used directly, but is used to correct the absolute frequency of the internal reference many times per second.

## Hold-over mode

When the GPS signal is lost, the last GPS reading is used as a hold-over correction value for the internal reference. The hold-over correction value is no longer used, but instead the factory-set correction value is used, when any of the following occur:

- when GPS is disabled.

- when Reference Source is set to Internal.
- when the FieldFox resumes from Standby mode or shut down.

### Frequency Reference Status

When switched to Ext or GPS, one of the following annotations appears in the lower-left corner of the screen:

- **EXT R** – External reference is selected.
- **GPS R** – GPS reference is selected.
- **GPS H** – Internal Reference is used with last 'hold-over' correction reading.

If the FieldFox does NOT find an appropriate **Ext** or **GPS** reference signal, then **Ext Ref UNLOCKED** is displayed in the lower-left corner of the graticule area. This can occur when any of the following conditions exist:

- NO reference signal is present.
- A low or very high-level external reference signal is present. For best results, the signal should be between -5 dBm and +5 dBm.
- The external reference is off-frequency.

To learn the expected measurement accuracy when connected to a frequency reference source, see the FieldFox specifications in **“Specifications/Data Sheet” on page 829**.

### Reference OUT

The internal 10 MHz frequency reference is available from the Ref/Trig output connector on the right-side panel. Use this signal as a common frequency reference when making measurements using external equipment. See this connector in **“Top Panel” on page 41**.

## Variable Voltage Source (Opt. 309)

### CAUTION

**IMPORTANT!** Noise Figure mode uses DC variable voltage source (VVS) – (Option 309) during the measurements. The voltage might be as high as 28V during the measurement. During the noise figure measurement, always make sure there are no voltage sensitive devices connected to the DC SMB output port. Refer to **Chapter 28, “Noise Figure Mode (Option 356)”, on page 649**.

When you initially change the FieldFox mode to Noise Figure, the FieldFox displays the following message for ten seconds:

**"Ensure your Noise Source is connected to the VVS DC Output  
It (VVS) will be driven up to +28V during the measurement".**

---

An internal DC source, available with Opt. 309, may be used to provide power for external devices. The maximum power available is 8 watts.

The voltage is output through an SMB (m) output connector located on the left-side panel. See the connector in “[Left Side Panel](#)” on page 43.

An optional SMB (f) to BNC (m) bias-tee power cable is available with Keysight part number: N9910X-713.

The following status line is provided near the top of the FieldFox screen.

Figure 30-9

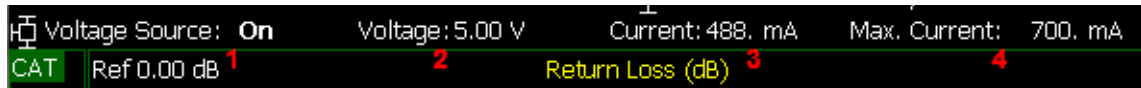

#### Voltage Source Status Line

1. Voltage source state: ON, OFF, TRIPPED.
2. **Voltage** setting from 1.00 V to 32.00 V with .01 V resolution.
3. **Current:** The amount of current (in Amperes) being drawn from the source.
4. **Max Current:** A conservative estimate of maximum current possible given the present voltage setting. The actual ‘trip’ level may be slightly different.

#### How to make Voltage Source settings

- Press **System 7**
- Then **System Configuration**.
- Then **Voltage Source**.
- Then **Source ON OFF** to enable and disable the voltage source output.
- Then Voltage x.xx V Using **▲▼** arrows, the rotary knob, or numeric keypad, enter a value between 0.001 and 32 volts.
- **Clear Overload** If the voltage source becomes ‘TRIPPED’ press to re-enable the voltage source output. Then set **Source ON**.
- **Status Line ON OFF** Turn ON and OFF the voltage source status line that appears near the top of the screen. The status line is always ON while making Voltage Source settings.
- **Hi Impd. Load ON OFF** Enables/Disables low current use (Step) and high current use (Ramp). Default = OFF (Low current (Step)).

#### Security Level

For security reasons, you can prevent frequency information from appearing on the FieldFox while in SA, NA, or CAT modes.

#### How to set Security Level

- Press **System 7**

- Then **System Configuration**
- Then **Security Level**
- Then choose from the following:
  - **None** All frequency settings are visible.
  - **High** Frequency information is blanked from the following:
    - Display annotation
    - Softkeys
    - Marker display and marker table
    - Calibration properties
    - All settings tables
    - Limit line tables
    - All saved.png files
  - Any of the following will re-display frequency information:
    - Set to **None**, Preset, Mode Preset, or FieldFox restart.

## Date and Time, Format, and Time Zone Settings

Set the local date and time, Date and Time format, and Time Zone that is shown on the FieldFox screen. The Date and Time is also used to identify files that are saved.

The Date and Time can also be set by synchronizing with GPS satellites. Learn more in **“GPS” on page 746**.

### How to Update Date and Time using Internet

This method of setting the Date and Time does NOT have the security restrictions of the other methods (listed below).

This method will NOT set the correct Time Zone. You must do that using the manual method. See below.

- Press **System 7**
- Then **System Configuration**.
- Then **More**
- Then **Update Time using Internet**
- Connect a LAN cable that is also connected to the Internet.
- Then press **Update Time using Internet**. When successful, a message is displayed indicating the amount of time correction that occurred.

- Optional: Set the following when a Proxy server is used to connect to the internet:
  - **Proxy Host** – Enter the name of the proxy host.
  - **Proxy Port** – Enter the port number of the proxy host.

## How to MANUALLY set Date and Time, Format, and Time Zone

### NOTE

Because of licensing security, the manual and GPS Sync methods to set Date and Time are restricted as follows:

Can be set backward no more than 5 hours at a time.

Can be set forward any amount of time.



Can be set backward or forward no more than once in a day. A new day begins at midnight.

There is no restriction for setting the Time Zone.

To change the Date and Time backward a significant amount, send an email to [csg.servicedesk@keysight.com](mailto:csg.servicedesk@keysight.com).

### NOTE

BEFORE manually setting the Date and Time, be absolutely certain that the Time Zone setting is correct.

- Press **System** **7**
- Then **System Configuration**.
- Then **More**.
- Then **Date and Time**.
- Press the  arrows to highlight the row to be edited.
- Then press **Edit**.
- Use the  arrows or rotary knob to select the field to be edited.
- Use the  arrows or numeric keypad to edit that field.
- Press **Cancel** or **Done** when the edits are complete.
- Press **Done** to exit the Date and Time settings. The readout in the upper-right corner of the FieldFox screen will update accordingly.

## LAN Settings

Configure the LAN settings to be used to communicate with the Data Link Software and connect to the FieldFox for remote SCPI operation. Learn more about Data Link at: [www.keysight.com/find/fieldfoxsupport](http://www.keysight.com/find/fieldfoxsupport).

Use knob. Press [Edit] to make changes. Press [Done] to exit.	
Setting	Value
Current IP Address	192.168.1.102
Current Subnet Mask	255.255.255.0
Current Gateway	192.168.1.1
Hostname	A-N9912A-00000
Obtain IP Address using:	DHCP
Static IP Address	123.456.789.123.123
Static Subnet Mask	0.0.0.0
Static Gateway	0.0.0.0
Apply Settings at:	PowerUp

Table 30-1 LAN LEDs

LAN LEDs
<b>When FieldFox is connected to the LAN, the flashing LAN LEDs have the following definitions:</b>

Green: Flashing indicates packets are being transferred.

Yellow:

- Flash, pause = 10 Mbit link speed
- Flash, flash, pause = 100 Mbit link speed
- Flash, flash, flash, pause = 1 GBit link speed

### How to configure LAN settings

The first three ‘Current...’ settings can NOT be edited.

- Press System 7.
- Then System Configuration.
- Then More.
- Then LAN.
- Use the  arrows to select one of the following, then press Edit.
- **Hostname** Change the name that can be used to address the FieldFox if your server supports this feature. The default hostname is generated automatically.
- **Obtain IP** Choose from:
  - **DHCP** - IP Address is assigned dynamically. If your server supports this feature, the IP Address for the FieldFox is assigned each time it is started.

- **Static** - Set the IP Address manually. The Address remains until you change it.
- **Static IP Address** - Enter the IP Address – including periods - in the format nnn.nnn.nnn.nnn

**NOTE**

For all FieldFoxes with firmware  $\leq$ A.08.18 and  $\leq$ A.09.50 FW, when using Static IP addresses:

- Either a valid Static Gateway is required or 0.0.0.0.
  - Either a valid Static DNS is required or 0.0.0.0. (If entry is available.)
- 
- **Static Subnet Mask** - Enter the Subnet Mask – including periods - in the format nnn.nnn.nnn.nnn
  - **Static Gateway** - Enter the Static Gateway – including periods - in the format nnn.nnn.nnn.nnn
  - **Static DNS** - Enter the Static DNS – including periods - in the format nnn.nnn.nnn.nnn
  - **Apply Settings** Choose from:
    - **Power Up** The above settings take effect when the FieldFox is started.
    - **Now** The above settings take effect immediately.

**NOTE**

To make the LAN settings persist after power up, toggle Apply Settings to Now then back to Power Up. You should see a message indicating that the LAN config file was saved.

- 
- Press **Done Edit** when finished.

## Power ON

When the FieldFox is without a power source, this setting allows the FieldFox to power ON when the DC Adapter is inserted without pressing the power button.

### How to set Power ON

- Press **System 7**
- Then **System Configuration**
- Then **More**
- Then **Power ON**
- Then choose from the following:
  - **Auto** The FieldFox will power ON when the DC Adapter is inserted.

- [Manual](#) The FieldFox will power ON only when the power button is pressed.

## FieldFox Package Installer

The FieldFox Package Installer enables you to download new versions of firmware from either a USB memory or SD Card. Additionally, the Utility softkey enables you to backup user files or restore user files.

### How to run the Installer

#### NOTE

Before running the Installer to update your firmware, you might want to back up your user data. Refer to [“How to restore files” on page 768](#).

- Press [System 7](#).
- Then [System Configuration](#).
- Then [More](#).
- Then [Firmware Update](#).
- Then [Start Installer](#).
- The Installer software opens after a couple of seconds.

#### NOTE

If no files are displayed, verify that a USB memory or SD Card is installed and press [Refresh List](#).

- Then the  arrows or the knob to scroll to the firmware you want to install.
- Press [Start Install](#).
- “Current Step Progress:” bar and a “Total Progress:” bar are displayed along with this message: “Copying package. Do not remove install media.”
- When the installation is completed, the FieldFox reboots.

### How to backup files

This procedure backs up your user data to a USB or SD card. See also [“How to restore files” on page 768](#).

#### NOTE

If you backup multiple versions of the user files, the FieldFox appends a “\_#” to each subsequently stored file. During restore, the file with the highest appended number is loaded into the FieldFox.

From the initial Installer menu:

- Press **Utility**
- Then **Backup Data**
- A message is displayed: “Choose backup file location.”
- Then choose either **SD Card** or **USB**
- A progress bar and a message is displayed: “Saving user data...”
- Press **Cancel** to exit without backing up your files and returning to the initial Installer menu.

### How to restore files

This procedure restores user files from a USB or SD card. See also [“How to backup files” on page 767](#).

#### CAUTION

Restoring files overwrites the existing user data on the FieldFox.

#### NOTE

If you backup multiple versions of the user files, the FieldFox appends a “\_#” to each subsequently stored file. During restore, the file with the highest appended number is loaded into the FieldFox

If you stored any user files to a USB or SD card, this procedure restores those files.

From the initial Installer menu:

- Press **Utility**
- Then **Cancel** to exit without restoring your files and returning to the initial Installer menu.

Or

Press **Restore Data**

- A message is displayed: “This option will COMPLETELY ERASE existing user data. ARE YOU SURE?”
- Then **No** to return to the previous menu without restoring files.

Or

Press **Yes**

- Then choose either SD Card or USB

A progress bar and a message is displayed: “Restoring user data...”

## Service Diagnostics

- The Service diagnostics menu is generally used to display service-related information. To access these menu items, press **System 7** then **Service Diagnostics**.

### System Information

The System information table shows important information about your FieldFox. The following is the most useful information:

- **Model Number** – FieldFox model
- **Serial Number** – Identification number of your FieldFox
- **Firmware Release** – The currently installed version of software. Check to see if you have the latest firmware at:  
[www.keysight.com/find/fieldfoxsupport](http://www.keysight.com/find/fieldfoxsupport)
- **Network Identity** – The network name and current IP address of your FieldFox.
- **Reflectometer Factory Cal** - The Factory (CalReady) Calibration shows the date and time that the factory cal was performed for each test port and the Thru connection. The format is P1 <date time>, P2 <date time>, P1-P2 <date time>. The factory calibration is updated when you send your FieldFox to Keysight for Instrument Calibration. Learn more in “**Instrument Calibration**” on page 831.

### Event Log

The Event Log shows the information that has appeared on the FieldFox screen. The most recent information is at the top of the table.

Press **Clear Events** to erase this information.

### Battery

Learn more in **Chapter 33, “Working with the Lithium-Ion Battery”, on page 793.**

### Internal Temperatures

Learn about the importance of the internal FieldFox temperatures in “**FieldFox High Temperature Protection**” on page 32.

### Erase User Data

All data that you have written to the FieldFox can be erased with the press of a button. You would do this if your FieldFox is located in a secure environment and must be routinely erased of sensitive data.

All data is removed from the FieldFox internal “UserData” partition. This includes all State files and Trace + State files (\*.sta), all Data files (\*.csv, \*.snp), all Picture files (\*.png), all Cal Kit files, and all Cable files.

External media that is inserted (mini-SD card or USB flash drive) is NOT erased.

The “Lost Clusters” folder and files are NOT erased because they are part of the file system housekeeping.

## How to Erase User Data

- Press **System 7**.
- Then **Service Diagnostics**.
- Then **Advanced**.
- Then **Erase User Data**.
- Then **Confirm Erase**.
- Then the following occurs:
  - All data files and folders are deleted from the “UserData” partition.
  - The FieldFox is rebooted, which manages the newly-freed data and re-writes the factory cal kits and cable files.

## Understanding the Fan Controls

### CAUTION

If the FieldFox displays a "Fan Stuck" or "Error: Internal Fan has stopped spinning", to avoid incorrect measurements and possibly damaging your FieldFox, shut your FieldFox down and contact Keysight. Refer to ["Contacting Keysight" on page 5](#).

The fan is replaceable, but not removable by non-Keysight trained personnel.

This section contains the following:

- ["How to find the Fan Control Softkey Menu"](#)
- ["Fan Error Messages" on page 772](#)

### How to find the Fan Control Softkey Menu

This section discusses how to locate the fan control softkeys to monitor your fans performance (i.e., the fan control softkeys are for informational purposes only).

1. Press **System 7**.
2. Then **Service Diagnostics**.
3. Then **Advanced**.
4. Then **Fan Control**.
5. These softkeys are for informational purposes only:
  - **Fan Mode Auto** – Manual is not selectable.
  - **Manual Speed [Medium]** – this is the default. No other speeds are selectable.
  - **Fan RPM** – displays the current fan RPM.
  - **Fan Temp** – displays the current fan air temperature.
  - **Back** –to exit the fan control softkey menu

Figure 30-10 Fan Control Softkeys – Informational Use Only (Not Editable)



## Fan Error Messages

The FieldFox displays fan error messages, when the fan is not functioning properly. Refer to [Figure 30-11](#), [Figure 30-12 on page 773](#), and [Figure 30-13 on page 773](#).

### CAUTION

If the FieldFox displays a "Fan Stuck" or "Error: Internal Fan has stopped spinning" message, to avoid incorrect measurements and possibly damaging your FieldFox, shut your FieldFox down and contact Keysight. Refer to ["Contacting Keysight" on page 5](#).

If the FieldFox displays a "Fan: Service" message the fan needs replacing. Call Keysight and request a fan kit. Refer to [Figure 30-13 on page 773](#) and to ["Contacting Keysight" on page 5](#).

Figure 30-11 Initial Fan Stuck Error Message – Displays For a Few Seconds

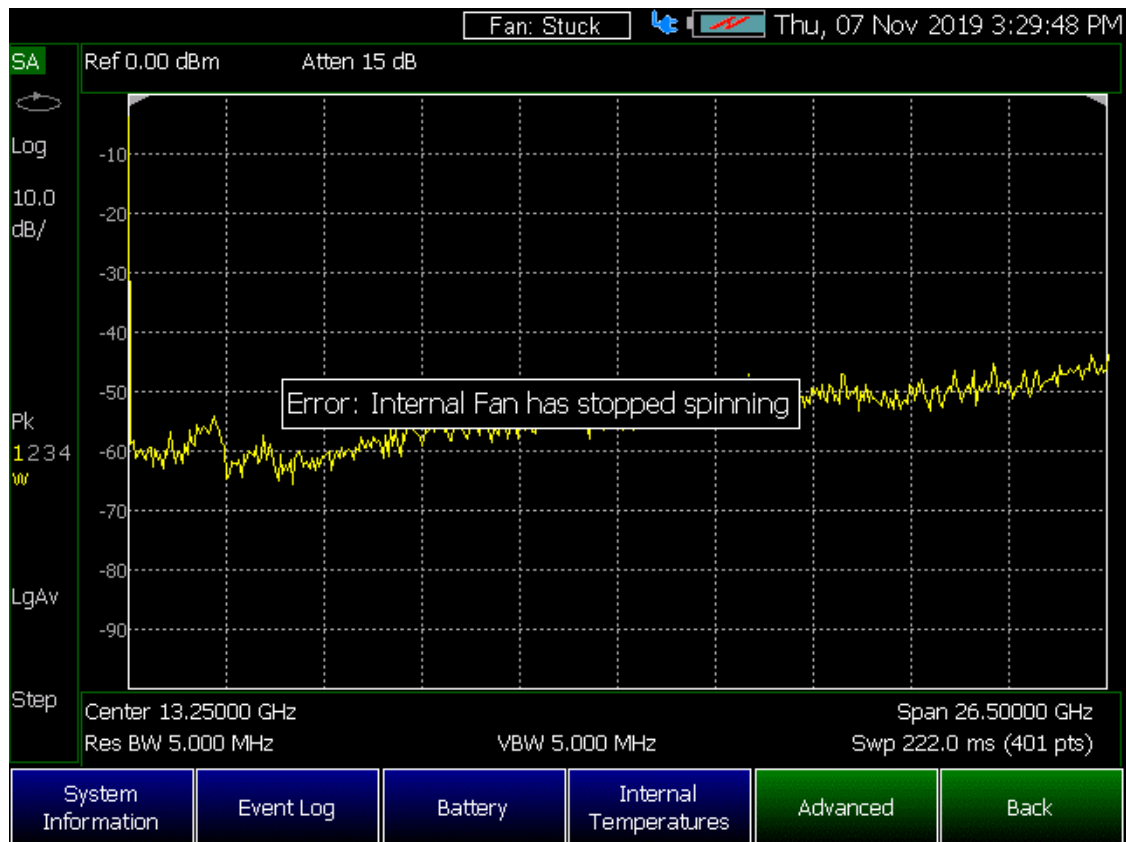

Figure 30-12 Persistent Fan Stuck Error Message

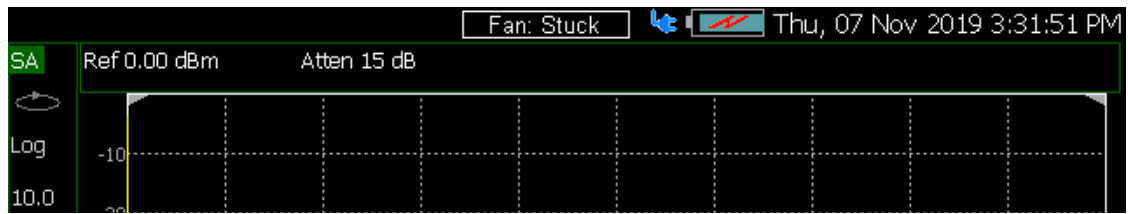
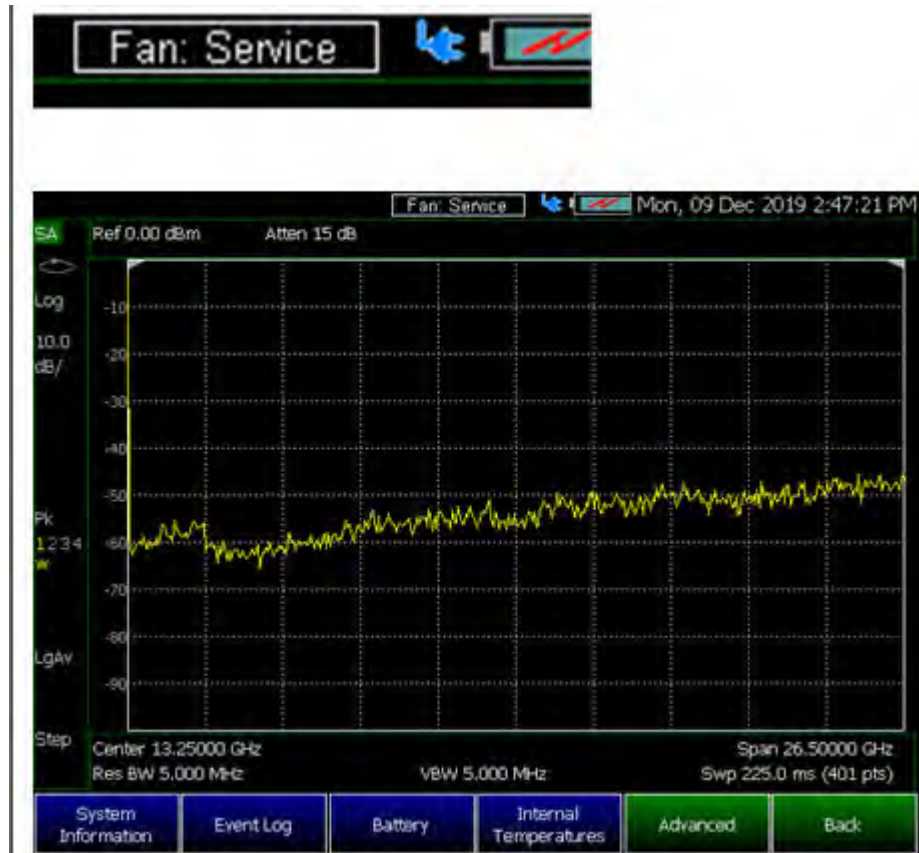

Figure 30-13 Fan: Service Message



System Settings  
Understanding the Fan Controls

## 10 File Management

The FieldFox can save any of the following types of files:

- Current settings and calibration
- Trace data (\*.csv, \*.S1P, \*.S2P)
- Picture of the FieldFox screen

In addition, files can be saved to the internal memory, a USB Flash drive, or a standard SD card.

### **In this Chapter**

[“Save Files” on page 778](#)

[“Recall Files” on page 782](#)

[“Move \(Copy\) Files” on page 782](#)

[“Set File Type and Select Device” on page 783](#)

[“Manage Files” on page 786](#)

[“Manage Folders” on page 788](#)

[“Edit Keywords” on page 789](#)

[“Prefixes and Suffixes for Filenames” on page 789](#)

### **See Also:**

[“Erase User Data” on page 769](#)

## Saving and Recalling Files

### NOTE

FieldFox State files are intended to be recalled on the same instrument model on which they were saved. Sometimes you may be able to recall them within model families. An error will result when trying to recall a state file that was saved on a different model family.

---

The FieldFox model families are:

- N991x (VNA/SA) model family
- N992x (VNA) model family
- N993x (SA) model family
- N995x (VNA/SA) model family
- N996x (SA) model family

### Save Files

#### How to Save a File

- Press **Save/Recall 9**
- Then **Save**
- At the top of the current 'labeler' screen (see following image) check the **File Type** to save and **Device** (Internal, USB, Storage Card) to which the file is saved. Learn how to change these settings in **“Set File Type and Select Device” on page 783**.
- Then use the labeler to specify a filename.

### CAUTION

If you are having difficulty saving to a USB flash drive, it may be a timing issue. The turn-around time for “file open, write data, file close” to a USB drive is much longer than to FieldFox’s internal memory. Alternative methods are:

1. Save your content to the FieldFox’s internal memory; and then move your files off to a USB flash drive using FTP SCPI programming. Refer to **Using FTP with FieldFox** and to the **FieldFox Programming Guide**.
  2. Save your data to the FieldFox’s internal memory, then move the data to a PC using a binary block transfer, and delete the data from the FieldFox’s internal memory. An example for transferring an image: [http://na.support.keysight.com/fieldfox/help/Programming/webhelp/Examples/Transfer\\_Image\\_to\\_PC.htm](http://na.support.keysight.com/fieldfox/help/Programming/webhelp/Examples/Transfer_Image_to_PC.htm). Please note that the receiving computer program needs to be able to handle the binary block transfer. See also **FieldFox Programming Guide**.
-

**NOTE**

Insert only ONE USB flash drive in the FieldFox when saving or copying files.

Saving MATLAB files

**NOTE**

If you have Option 351 I/Q Analyzer option, you can directly save your data as MATLAB files (\*.mat). Refer to [Chapter 11, “IQ Analyzer \(IQA\) – Option 351”, on page 285](#) and to [Chapter 32, “File Management”, on page 777](#).

If you have the FieldFox’s Remote Server mode (89600 VSA software connectivity), you can use the VSA software to capture and record your data as MATLAB files (\*.mat). Learn more about FieldFox and 89600 VSA software, refer to [Chapter 17, “Remote Server Mode \(Requires SA Hardware/SA Option 233\)”](#) and to <http://rfmw.em.keysight.com/wireless/helpfiles/89600B/WebHelp/89600.htm>.

Figure 32-1 I/Q Analyzer Mode (IQA) MATLAB File Save

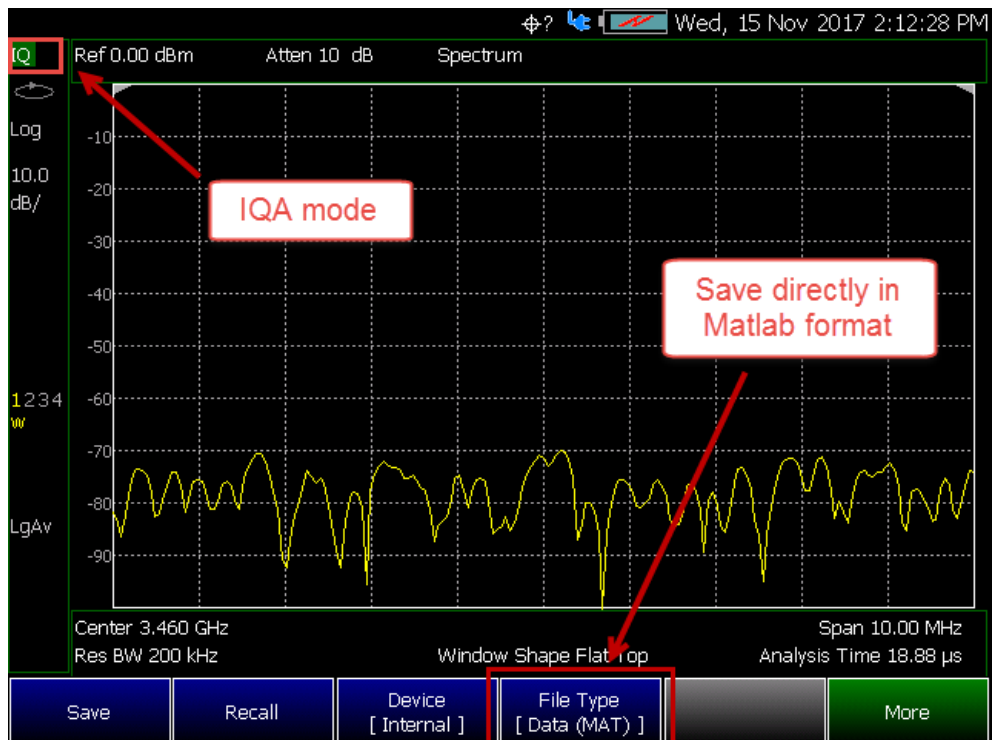
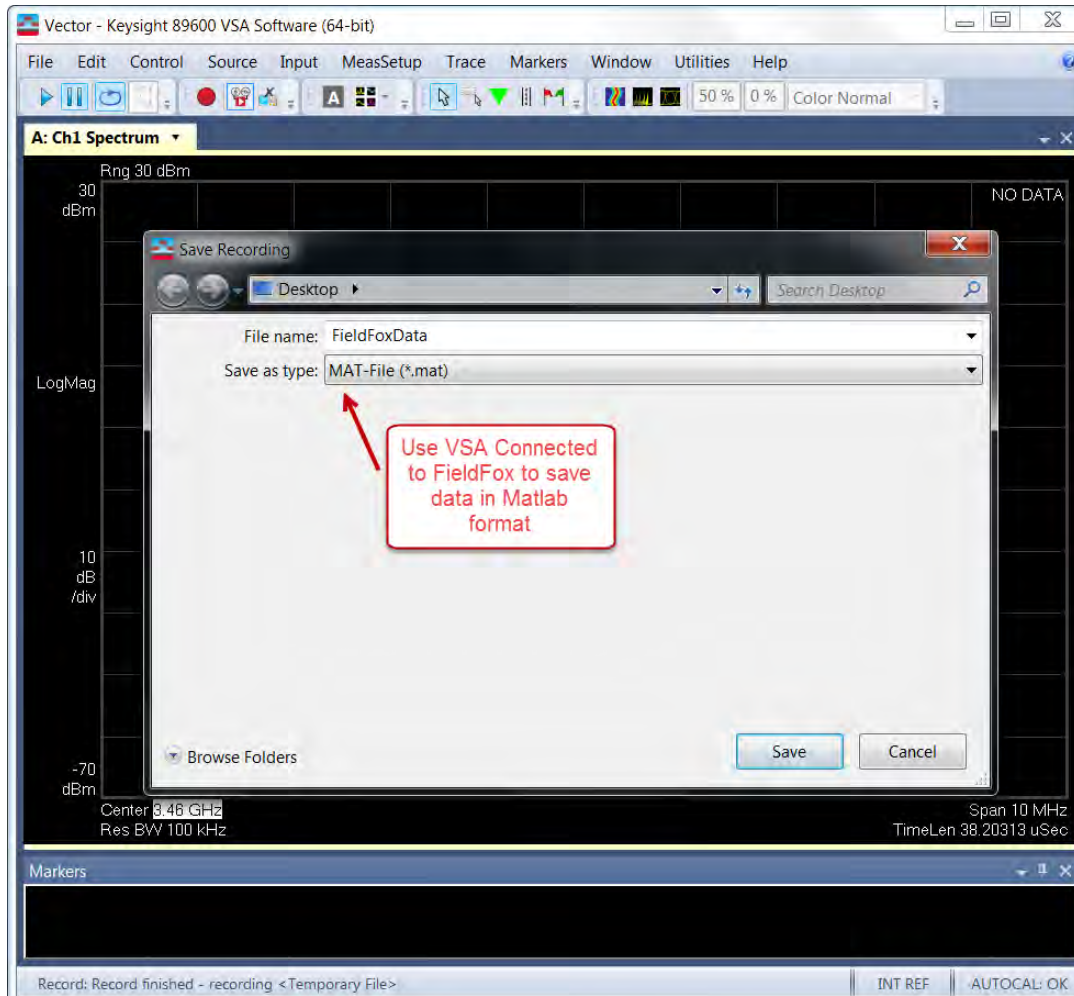

Figure 32-2 VSA Software MATLAB File Save



### How to use the FieldFox labeler

The FieldFox labeler is used to edit or change the current filename. It is also used for many other labeling functions, such as creating a title, prefix, and keyword to display on the FieldFox screen. Learn about Titles in **“How to Manage files” on page 786**.

- Move the cursor (see section below, How to move the cursor), then press **Select** to add the cursor character to the end of the existing filename.
- **Back Space** to erase the last character(s) from the end of a filename.
- Press **Shift** to toggle keyboard between lower case and upper case characters.
- Press **Alt Keyboards** to display the different keyword choices.

#### NOTE

You can select either an ABC or Qwerty style keyboard. Refer to **“Alpha Numeric Editing” on page 749**.

The preselected keywords (File, Site, and so forth) can be selected just like a single character. These keywords can also be edited. Learn more in [“Edit Keywords” on page 789](#).

Figure 32-3 The FieldFox labeler

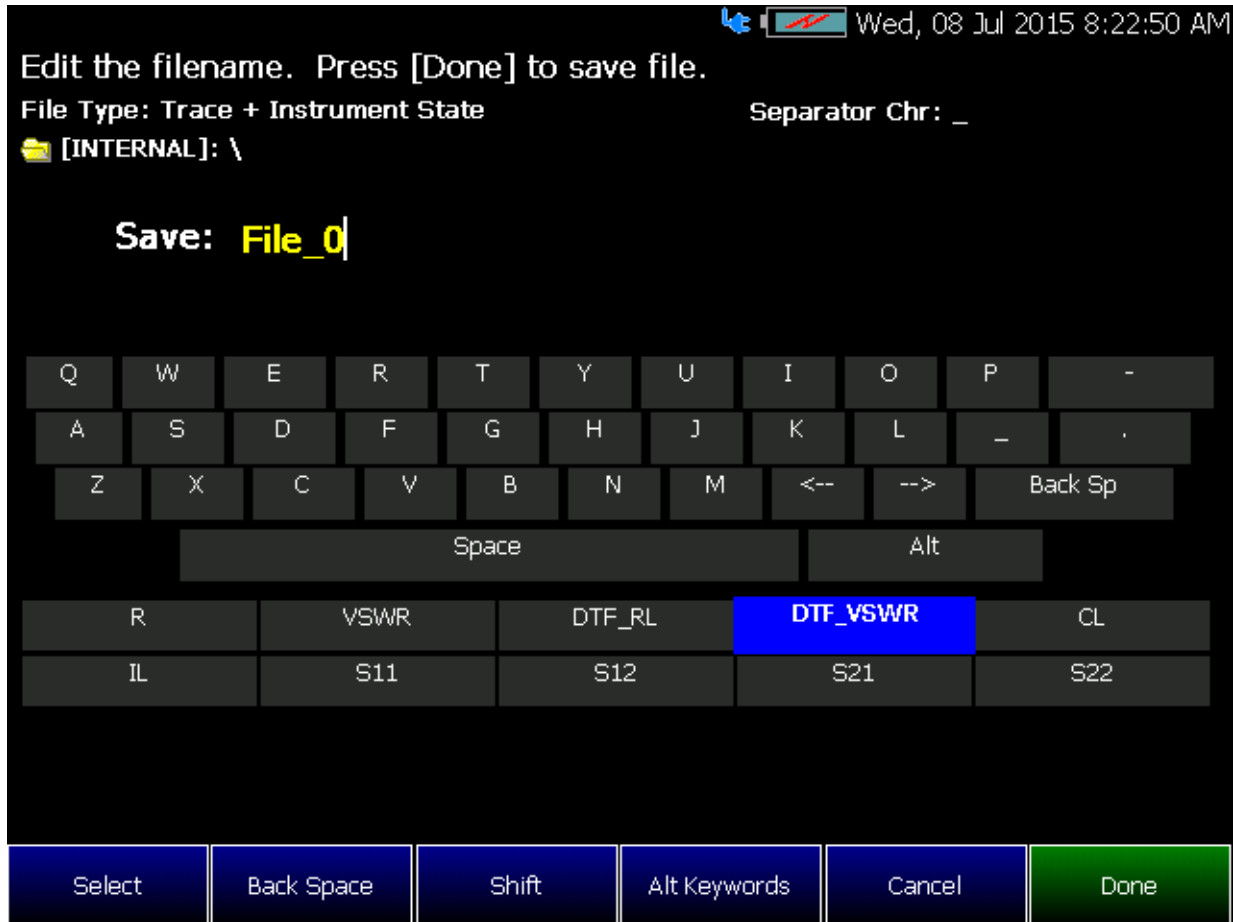

In the graphic above, the current filename is **File\_0**. The cursor is on the custom **DTF\_VSWR** keyword. The file will be saved to USB (flash drive). File Type is “Trace + State” (Instrument State).

### How to move the cursor

- Use the rotary knob to move cursor on the same row. The cursor will change rows when it comes to a row end.
- Use the  arrows to move the cursor up and down the rows.

### When the current filename is complete

- Press **Done** to save the file to the specified filename.
- Press **Cancel** to close the labeler without saving a file.

- If the filename already exists, you are prompted to choose from the following:
  - Press **Yes** to overwrite the existing file.
  - Press **Cancel** to return to edit the filename.

## Recall Files

The FieldFox can recall **State** files, **Trace + State** files, and image files.

### State Files

ALL FieldFox instrument settings for ALL Modes are saved and recalled in a \*.sta file. If error correction is ON in CAT or NA Mode, then calibration data is also saved and recalled.

If error correction is OFF (CalRdy is active), calibration data is NOT saved in the \*.sta file. When a Trace + State file is recalled on a FieldFox other than the one it was saved on, differences in the CalRdy calibration data may result in differences between the displayed traces.

### Image Files

The FieldFox can open and display \*.png, \*.jpg, and \*.jpeg images.

### How to Recall a File

#### NOTE

Before recalling a file, first Select the Device and Location from which the file will be recalled. See the following section for more information.

- Press **Save/Recall 9**
- Then **Recall File** or **Enter**
- Navigate to the file to be recalled using the Up/Down arrow keys.
- Optional: **Sort by Name** to list the current files by name.
- Optional: **Sort by Date** to list the current files by date.
- Optional: **Next Page** if available, to go to the next page of filenames.
- Optional: **Previous Page** if available, to go to the previous page of filenames.
- Then **Recall File** or **Enter**.
- **Cancel** to cancel recall file and return to the previous menu.

## Move (Copy) Files

The FieldFox can **Move** files (i.e., including **Trace + State** files, and image files).

## How to move a file

- Press **Save/Recall 9**
- Then **Device** to be copied from (i.e., Internal, SD, or USB). Refer to **“Set File Type and Select Device” on page 783**.
- Then **More**
- Then **Manage Files**
- Then **Select Files**
- Navigate to the file(s) to be copied using the Up/Down arrow keys or the knob.
- Then **Copy**
  - Select the destination device using the softkeys:
    - **Copy to Internal** Copies to FieldFox’s internal memory.
    - **Copy to USB** Copies to a USB memory device.
    - **Copy to SD Card** Copies to a SD/SDHC memory card.
    - **Cancel** to cancel copy file and return to the previous menu
  - Use the close folder icon or the open folder icon to locate the target folder for your files.
  - Then **Do Copy** copies files to selected location and FieldFox displays a confirmation message of a successful file copy.
  - **Cancel** to cancel copy file and return to the previous menu.

## Set File Type and Select Device

The following File TYPE and DEVICE settings are used to determine the type of file to save, and the location to be used for all file operations.

These two settings remain through an instrument preset, but are reset to the default values when the FieldFox power is shutdown.

### Select Device (location of File Save/Recall)

- Press **Save/Recall 9**
- Then **Device** to set the LOCATION where the file is to be saved, recalled, or moved. Choose from the following:
  - **Internal** Saves/Recalls/Moves (Copies) files to/from the FieldFox internal memory. To specify a folder, first select Manage Folders (learn how in **“Manage Folders” on page 788**). The Data Link software will read data ONLY from the \UserData folder.

- **SD Card** Saves/Recalls/Moves (Copies) files to/from the SD card (not included), inserted in the card slot. See **“Take the FieldFox Tour” on page 38**. Only the root folder is available.
- **USB** Saves/Recalls/Moves (Copies) files to or from a USB Flash drive (not included) that is inserted in one of the USB connectors. Only the root folder is available.

**NOTE**

Insert only ONE USB Flash Drive in the FieldFox when saving or copying files.

---

### How to set File Type

- Press **Save/Recall 9**
- Then **File Type**. Choose one of the following:
  - **State** Saves ALL FieldFox instrument settings for ALL Modes to a \*.sta file. If a calibration is ON in CAT or NA Mode, calibration data is also saved. This file can be opened ONLY by a FieldFox. State files can be saved between compatible FieldFox models. See note in: **“Saving and Recalling Files” on page 778**.
  - **Trace+State** Saves the current trace and instrument settings to a \*.sta file. In SA Mode, all traces are saved. This file can be opened ONLY by a FieldFox. When recalled, the FieldFox sweep is set to Hold.

**CAUTION**

When using RTSA, the Density Spectrum information is not saved using Trace+State. Only the last displayed trace settings is saved.

---

- **Picture (PNG)** Saves a 640 x 453 pixel image of the FieldFox screen to a \*.png file. The picture does NOT include the softkeys.
- **Data (csv)** Saves trace data from the current Mode to a \*.csv file. This format can be imported into spreadsheet software such as Microsoft Excel. Column A is always the frequency at which the data is measured.
  - In **SA Mode**, all visible data traces are saved. Each trace is saved to a separate column that is labeled with the Trace State.
  - In **CAT** and **NA** Modes, only the data trace is saved – not the memory trace.
  - In **Power Meter** (with Option 208 Frequency Offset Power Sensor (FOPS)), all visible traces are saved. Each trace is saved to a separate column labeled **Output Power** or **Memory**.
  - In **VVM** Mode, NO data is saved.

- **Data (S1P) / (S2P)** Saves **CAT** and **NA** Mode trace data to an \*.S1P or \*.S2P file, depending on the active measurement. This file format is used by CAE programs such as Keysight's Microwave Design System (MDS) and Advanced Design System (ADS). It can also be imported into spreadsheet software such as Microsoft Excel.

### About SNP Files

The SNP file includes header information, and the following data:

- S1P - saves 1-port (receiver) data for the active data trace. \*.s1p Files contain 1 stimulus value and 1 S-parameter (total of 3 scalar values) **Stim Real(Sxx) Imag(Sxx)**
- S2P (NA Mode ONLY) - saves 2-port data for the active trace. \*.s2p Files contain 1 stimulus value and 4 S-parameters (total of 9 scalar values) **Stim Real(S11) Imag(S11) Real(S21) Imag(S21) Real(S12) Imag(S12) Real(S22) Imag(S22)**
- Only data traces are saved – not memory traces.

### Corrections

- When parameters are corrected, data is returned even when not displayed. Data is returned with the correction type that is applied for each S-parameter. The correction type for each S-parameter is annotated in the header.
- When parameters are NOT corrected or displayed:
  - With Smith chart and Polar formats, Real/Imag zero-filled data appears as (1.0, 0.0).
  - With all other formats, LogMag/Phase zero-filled data appears as (0.0, 0.0).

### > Display formats

In CAT Mode, S1P files are always Magnitude (dB) / Phase (angle) format.

In NA Mode:

- Smith chart and Polar display formats are ALWAYS saved in Real/Imag data pairs.
- All other display formats are saved in LogMag/Phase (dbAngle).

### > What Data Processing functions are included in saved SNP Data:

In NA Mode, the data processing functions (such as trace math) that are included in the SNP data depends on a Preference setting. Click **System**, then **Preferences**, then **Preferences**, then scroll to **NA, SNP File Save**, then select from the following:

- **Default** – SNP data does NOT include smoothing. SNP data saves are taken AFTER data processing (location 2) on the processing chain.
- **Advanced** – SNP data includes the following:
  - With Smith or Polar display format, SNP data saves are taken BEFORE most processing (location 1 on the data processing chain).
  - With any other display format, SNP data saves are taken just AFTER Formatting and Smoothing is applied (location 3 on the data processing chain). For each non-active trace, SNP trace data is reprocessed using the data processing chain of the active trace.

See the FieldFox data processing chain at the **Supplemental Online Help:** <http://na.support.keysight.com/fieldfox/help/SupHelp/FieldFox.htm> Learn more about System Preferences in “**Preferences**” on page 740.

## Manage Files

Files that are stored in the FieldFox internal memory, standard SD card, and USB Flash drive, can be copied to another device or deleted.

### How to Manage files

- Press **Save/Recall 9**
- Then **Device** to select the location (Internal, USB, or standard SD Card) of the file to copy or delete.

#### NOTE

When selecting Internal, it may also be necessary to first select Manage Folders to specify an active folder which contains the files to copy or delete. Refer to “**Manage Folders**” on page 788.

- 
- Then **More**
  - Then **Manage Files**
  - Then choose from the following:
    - **Select Files** Selects a file or files to sort, copy, or delete.
    - **Sort**
      - **Sort by Name** Sorts the displayed list of files by name.
      - **Sort by Date** Sorts the displayed list of files by date.
    - **Copy** Select a file or files to copy.
  - Then select a device to copy the file to. Choose from **Copy to Internal**, **Copy to USB** (must be inserted), or **Copy to SD Card** (must be inserted).

- **Do Copy** to complete the file copy to the media/folder selected.

**NOTE**

Copy can be done to any FieldFox internal folder, standard SD folder, or USB storage device.

---

- **Delete**
  - **Yes** The selected file is deleted.
  - **Cancel** To cancel Delete and return to previous menu.
- **More**
  - **Select Files** Selects a file or files to sort, copy, or delete.
  - **Select All** selects all of the displayed files. All files that are displayed are to be copied. Then select a device and a folder to copy the file to. Choose from Internal, USB (must be inserted), or SD Card (must be inserted).
  - **Clear All** Deselects all of the displayed files.
  - **Rename Files**

**NOTE**

For more on renaming folders/files, refer to **“How to use the FieldFox labeler ” on page 780** and **“Prefixes and Suffixes for Filenames” on page 789**.

---

- Enter the string in the filename or filenames that are to be replaced.

**NOTE**

**String to Replace** is case sensitive.

---

- **Replace With** Enter the string that is to be replaced by the characters entered with the String to Replace softkey.
- **Prefix** Enter a prefix (one time) that the current filename or filenames are to be renamed. To add a prefix to subsequent filenames (persistent), refer to How to edit the Prefix and Suffix (Auto Append) in **“How to edit the Prefix and Suffix (Auto Append)” on page 790**.
- **Suffix** Enter a suffix that the current filename or filenames are to be renamed.
- **Do Rename** Enable renaming of the current file or files.

**NOTE**

Insert only ONE USB Flash Drive in the FieldFox when saving or copying files.

---

## Manage Folders

You can create new folders, delete old folders, and select the active folder to which files can be saved. The Parent folder [...] is listed when not in the root directory.

### Press Save/Recall 9

- Press **Save/Recall 9**
- Then **More**
- Then **Manage Folders**
- Then choose from the following:
  - **Change Folder** Changes the active folder to which files can be saved. The active device and current folder is displayed at the top of the screen, and below, a list of files in that folder. Use the ▲▼ arrows to highlight a folder within the current folder. Each time the **Change Folder** softkey is pressed, the highlighted folder becomes the active folder.
  - **Create Folder** A new folder is created in the current folder. Select a name for the new folder from one of the displayed keywords: You can change these keywords using the following **Edit Keywords** function. Refer to Edit Keywords in **“Edit Keywords” on page 789**.
  - **Delete Folder** The **selected** folder and its contents are deleted after a warning prompt is displayed. A “Parent” folder or system folder can NOT be deleted.
  - **Copy Folder** The **selected** folder and its contents are copied and a message is displayed telling you that the copy was successful.
    - Then select a device to copy the folder to. Choose from **Copy to Internal**, **Copy to USB** (must be inserted), or **Copy to SD Card** (must be inserted).
    - **Do Copy** to complete the file copy to the media/folder selected.
  - **Rename** The rename folder menu opens and the selected folder’s title is displayed and available for editing.

#### NOTE

For more on renaming folders/files, refer to **“How to use the FieldFox labeler” on page 780**, and **“Prefixes and Suffixes for Filenames” on page 789**.

- 
- Press **Exit** when finished.

## Edit Keywords

The preselected keywords (FILE, SITE, and so forth) can be edited to meet your specific needs. Your keywords will remain in the FieldFox until you change them. Keywords are limited to 30 characters.

### How to edit keywords

- Press **Save/Recall 9**
- Then **More**
- Then **Edit Keywords**
- Then **Next Page** and **Previous Page** to view all keywords.
- Use the **▲▼** arrows to select a keyword to edit.
- When a keyword is selected, then press **Edit**.
- Then choose from the following:
  - Press **Select** to add the cursor character to the end of the selected keyword.
  - Press **Backspace** to erase the last character from the end of the selected keyword.
  - Press **Shift** to change from upper-case to lower-case and vice versa.
  - Press **Alt Keywords** to toggle through different keyword choices.

### How to move the cursor:

- Use the rotary knob to move the cursor along the same row. The cursor will change rows when it comes to a row end.
- Use the **▲▼** arrows to move the cursor up and down between rows.

### When the selected keyword is complete:

- Press **Done** to save all keywords and close the Edit Keywords labeler. These keywords will exist on the FieldFox until changed.
- Press **Cancel** to close the labeler without saving changes.

## Prefixes and Suffixes for Filenames

The prefix and suffix (Auto Append) can be used together to organize files. Once set and enabled, they are automatically entered as the beginning (Prefix) and end (Suffix - using Auto Append) of a filename when performing a Save

operation. These settings are persistent, until disabled. Refer to [“How to edit the Prefix and Suffix \(Auto Append\)” on page 790](#) and [“How to enable/disable Auto Append \(Suffix\)” on page 791](#).

**NOTE**

If you are only interested in adding a prefix or a suffix to a new file or files one time, refer to [“Manage Files” on page 786](#).

This section contains the following sections:

- [“How to edit the Prefix and Suffix \(Auto Append\)” on page 790](#).
- [“How to move the cursor” on page 781](#).
- [“When the Prefix is complete” on page 791](#).
- [“How to enable/disable Auto Append \(Suffix\)” on page 791](#).

### How to edit the Prefix and Suffix (Auto Append)

If you want to edit a prefix on a finite set of files one time, refer to [“Manage Files” on page 786](#).

- Press **Save/Recall 9**
- Then **More**
- Then **Prefix Suffix**
- Then choose from the following:
  - **Edit Prefix** to edit the prefix using the labeler. For more, refer to [“How to edit the Prefix and Suffix \(Auto Append\)” on page 790](#).
    - **Select** to add the cursor character to the end of the Prefix.
    - **Back Space** to delete the last character(s) from the end of the prefix.
    - **Shift** to toggle between capital letters and lower case letters.
    - **Alt Keywords** to display the different preselected keywords (File, Site, and so forth) can be selected just like a single character. These keywords can also be edited. See Edit Keywords.
    - **Cancel** to cancel edits and return to the previous menu.
- **Auto Append** (Suffix)
  - **OFF** to turn off Auto Append.
  - **Number** to auto-append a number using format “\_nnn” sequentially to all saved files.
  - **Date** to auto-append a date and time using format “\_YYYY-MM-DD.HH.MM.SS” sequentially to all saved files.

- **Number Suffix Reset** to reset Auto Append number to “\_001”.
- **Prefix**
  - **OFF** to disable the prefix. The Prefix softkeys are grayed out (inactive). Refer to How to enable/disable the Prefix (persistent) in **“How to enable/disable the Prefix (persistent)” on page 791.**
  - **Last File** to use the last filename saved, as your filename for subsequent saved filenames.
  - **User** to use the user-selected prefix.
- **Back** to return to the previous menu.

**NOTE**

When Last File is selected, the Edit Prefix and Auto Append softkeys are unavailable (grayed out). Refer to **“Prefixes and Suffixes for Filenames” on page 789.**

---

### How to move the cursor

- Use the rotary knob to move cursor on the same row.
- Use the  arrows to move the cursor up and down the rows.

### When the Prefix is complete

- Press **Done** to save the Prefix and close the labeler. This Prefix will exist on the FieldFox until it is changed.
- Press **Cancel** to close the labeler without saving changes.

### How to enable/disable the Prefix (persistent)

- Press **Save/Recall 9**
- Then **More**
- Then **Prefix Suffix**
- Then **Prefix**
  - **OFF** to disable the prefix on subsequently saved files. Edit Prefix, Auto Append, and Number Suffix Reset softkeys are grayed out (inactive).

### How to enable/disable Auto Append (Suffix)

- Press **Save/Recall 9**
- Then **More**
- Then **Prefix Suffix**
- Then **Auto Append**
- **OFF** to disable the Auto Append (Suffix) on subsequently saved files. Auto, and Number Suffix Reset softkeys are grayed out (inactive).

## Press Printing

The current screen or selected files can be printed using a PCL-compatible printer (like older HP Deskjet printer) connected to one of the FieldFox USB ports. Newer PCL3GUI photo and all-in-one printers are NOT supported.

Measurements can also be printed using the FieldFox Data Link software.

### How to print the current screen or a saved file

To save ink, first select an outdoor (white background) display color. Learn how in **“Display Colors” on page 729**.

- Connect the printer to a FieldFox USB port. **The print softkey will appear ONLY when a compatible printer is connected.**
- Then press **Save/Recall 9**
- Then **Print** and choose from the following:
  - **Printer & Page\nSetup** – Confirm that the printer is connected and configured properly. The Status line should read “Ready”.
  - Make other print settings as desired.
    - **Select Files\nfor Printing** – Print up to 16 \*.PNG images on one page that are stored on the Internal drive. Images can NOT be printed from the USB and SD card.
    - Edit the Quick Settings table to select up to FOUR Rows and FOUR Columns for up to 16 total images to be printed on a single page.
    - If necessary, edit the filenames to be printed.
    - Select **Done**. Then **Print Selected\nFiles** to begin printing.
      - **Print Current Screen** – Immediately prints the FieldFox screen using the selected Printer and Page Setup settings.

## 11 Safety Considerations

Keysight has designed and tested the FieldFox in accordance with IEC Publication 61010-1 Safety Requirements for Electrical Equipment for Measurement, Control and Laboratory Use, and the FieldFox is supplied in a safe condition. The FieldFox is also designed for use in Installation Category II and pollution Degree 2 per IEC 61010-1. Read the following safety notices carefully before you start to use this FieldFox to ensure safe operation and to maintain the product in a safe condition.

**NOTE**

The input terminals for this product are classified as Measurement Category None.

---

## For the FieldFox

**WARNING**

No operator serviceable parts inside except for the lithium-ion battery. Refer servicing to qualified personnel. To prevent electrical shock do not remove covers.

---

**WARNING**

If this product is not used as specified, the protection provided by the equipment could be impaired. This product must be used in a normal condition (in which all means for protection are intact) when attached to the AC-DC adapter.

---

**WARNING**

The unit may be used only in the operating conditions and positions specified by the manufacturer.

---

**WARNING**

Do not install substitute parts or perform any unauthorized modification to the product. Return the product to Keysight Technologies or a designated repair center for service to ensure that safety features are maintained.

---

**WARNING**

Applicable local or national safety regulations and rules for the prevention of accidents must be observed in all work performed.

---

**WARNING**

Ensure that the connections with information technology equipment comply with IEC950 / EN60950.

---

**WARNING**

Observe all ratings and markings of the instrument before connecting the instrument.

Maximum Input Voltages and Power:

RF Output Connector: 50V DC, +23 dBm RF

Ext Trig/Ref Connector: 5.5 V DC

RF Input:

+27 dBm RF,  $\pm 50$  VDC Max. (N991xA/B, N9925B, N9926A, N9928A, N993xA/B)

+23 dBm RF,  $\pm 50$  VDC Max. (N9923A, N9923AN)

+25 dBm RF,  $\pm 40$  VDC Max. (N995xA/B, N996xA/B)

DC Input: 19VDC, 4ADC

---

**WARNING**

When performing a measurement, ensure that the right safety and performance ratings of the instrument and accessories are used.

Do not expose the circuit or operate the instrument without its cover or while power is being supplied.

Do not operate the instrument in any environment at risk of explosion.

---

**WARNING**

---

Only Keysight approved accessories shall be used.

**WARNING**

---

Cleaning connectors with alcohol shall only be done with the instruments power cord removed, and in a well-ventilated area. Allow all residual alcohol moisture to evaporate and the fumes to dissipate prior to energizing the instrument.

**CAUTION**

---

The power cord and connectors shall be compatible with the connector used in the premise electrical system. Failure to ensure adequate earth grounding by not using the correct components may cause product damage and serious injury.

**CAUTION**

---

The measuring terminals on this instrument are designed to be used with external signals described in Measurement Category NONE, but NOT with external signals described in Categories II, III, and IV. The input of this instrument cannot be connected to the mains.

**CAUTION**

---

It is not recommended to operate the FieldFox when it is laying on its back on a table top or other flat surface, with the kickstand folded in. The cooling is less effective when the FieldFox is placed lying down flat on back of the instrument.

**CAUTION**

---

Use original packaging or comparable for shipping or transporting the instrument.

---

## For the AC/DC Adapter

**WARNING**

---

Use only the designated AC/DC adapter supplied with the instrument.

**WARNING**

---

Use only the designated power cord supplied with the AC/DC adapter.

**WARNING**

---

Operated at an ambient temperature: 0 to 40°C; full power rating; derate linearly at a rate of 3 watts per degree C, from 90W at 40°C to 45W at 55°C, 30W at -20°C.

Input: 100-240 VAC, 1.5-0.75A, 50-60 Hz

Output: 15 VDC, 6A

---

**WARNING**

To prevent electrical shock, disconnect the AC to DC adapter from the mains before cleaning. Use a dry cloth or one slightly dampened with water to clean the external case parts. Do not attempt to clean internally.

---

**WARNING**

When the FieldFox is connected to the AC/DC adapter, position the adapter so the power cord is readily accessible. The power cord is the disconnecting device. It removes main power to the AC/DC adapter. The FieldFox front panel switch is only for the DC power within the instrument, and not for the AC/DC adapter. Alternately, an AC switch or circuit breaker (which is readily identifiable and is easily reached by the operator) may be installed and used as a disconnecting device to remove mains power from the AC/DC adapter.

---

**WARNING**

To avoid overheating, always disconnect the FieldFox from the AC/DC adapter before storing the FieldFox in the backpack.

If you prefer to leave the FieldFox connected to the AC/DC adapter while inside the backpack, you can disconnect the AC/DC adapter from its AC power source to prevent overheating.

---

**WARNING**

Safety of any system incorporating the equipment is the responsibility of the assembler of the system.

---

**WARNING**

This is a Safety Protection Class I Product (provided with a protective earthing ground incorporated in the power cord). The mains plug shall only be inserted in a socket outlet provided with a protective earth contact. Any interruption of the protective conductor inside or outside of the product is likely to make the product dangerous. Intentional interruption is prohibited.

**CAUTION**

---

The AC/DC adapter has an auto-ranging line voltage input – be sure the supply voltage is within the specified range and voltage fluctuations do not to exceed 10 percent of the nominal supply voltage.

---

**CAUTION**

The AC/DC adapter is for indoor use only.

---

**CAUTION**

Never use a modified or damaged charger. Use the original AC-DC adapter ONLY.

---

**CAUTION**

The AC/DC adapter is designed for use in Installation Category II and Pollution Degree 2 per IEC 61010-1.

---

**CAUTION**

The instrument can operate with mains supply voltage fluctuations up to  $\pm 10\%$  of the nominal voltage.

---

Samples of this product have been type tested in accordance with the Keysight Environmental Test Manual and verified to be robust against the environmental stresses of Storage, Transportation and End-use; those stresses include but are not limited to temperature, humidity, shock, vibration, altitude and power line conditions. Test Methods are aligned with IEC 60068-2 and levels are similar to MIL-PRF-28800F Class 3.

## For the External Battery Charger (N9910X-872)

**CAUTION**

If charging batteries externally, use the optional external charger available from Keysight, or another SMBus charger of level II or higher.

Never use a non-SMBus charger because the battery issues commands over the SMBus to the charger to control the charge rate and voltage.

Never use a modified or damaged charger.

---

External AC/DC power supply, U.S. FCC compliance

Meets the required verification equipment authorization rules.

This device complies with part 15 of the FCC Rules. Operation is subject to the following two conditions: (1) This device may not cause harmful interference, and (2) this device must accept any interference received, including interference that may cause undesired operation.

## For the Battery

Lithium battery packs may get hot, explode, or ignite and cause serious injury if exposed to abuse conditions.

**This section contains the following:**

- “High Capacity Lithium Battery (N9910X-876)”
- “Standard Capacity Battery (N9910X-870)”

## High Capacity Lithium Battery (N9910X-876)

Lithium battery (High Capacity): N9910X-876 (battery Keysight part number: 1420-0937) is used to provide power to a family of portable microwave test instruments produced by Keysight Technologies. Be sure to follow these safety warnings:

External battery, U.S.  
FCC compliance

Battery storage:

The only instructions related to storage have to do with temperature and are listed below

- “Temperature (1 month): -20°C to +45°C
- “Temperature (6 month): -20°C to +40°C
- “Temperature (12 month): -20°C to +35°C

Rating:

10.8V 6400mAh 70Wh

### WARNING

Lithium-ion batteries:

- Must not be exposed to high temperatures (>70°C) or fire.
- Must be kept away from children.
- Must not be short circuited.
- Must be replaced only with Keysight qualified Li-ion batteries.
- If replaced or charged improperly, there is a danger of explosion.

### WARNING

Do not connect the positive terminal and negative terminal of the battery to each other with any metal object (such as wire).

### WARNING

Do not carry or store the battery with necklaces, hairpins, or other metal objects.

### WARNING

Do not pierce the battery with nails, strike the battery with a hammer, step on the battery, or otherwise subject it to strong impacts or shocks.

### WARNING

Do not solder directly onto the battery.

### WARNING

Do not expose the battery to water or salt water, or allow the battery to get wet.

### WARNING

Do not disassemble or modify the battery. The battery contains safety and protection devices, which if damaged, may cause the battery to generate heat, explode, or ignite.

**WARNING**

---

Do not place the battery in direct sunlight, or use or store the battery inside cars in hot weather. Doing so may cause the battery to generate heat, explode, or ignite. Using the battery in this manner may also result in a loss of performance and a shortened life expectancy.

**WARNING**

---

There is a danger of explosion if the battery is incorrectly replaced. Replace only with the same or equivalent type of battery recommended. Discard used batteries according to manufacturer's instructions.

**WARNING**

---

If you are charging the batteries internally, even while the FieldFox is powered off, the FieldFox may become warm. Allow for proper ventilation.

Do NOT run the FieldFox with the vents blocked or in the carrying case.

**WARNING**

---

Do not discharge the battery using any device except the FieldFox or the external battery charger (N9910X-872). When the battery is used in a device other than those specified, it may damage the battery or reduce its life expectancy. If the device causes an abnormal current to flow, it may cause the battery to become hot, explode, or ignite and cause serious injury.

The external battery charger discharges during recalibration.

**WARNING**

---

For a Korean battery safety consideration translation, refer to [Appendix D: "Korean Battery Safety Translation."](#)

**WARNING**

---

For a Russian battery safety consideration translation, refer to [Appendix E: "Russian Battery Safety Translation."](#)

**WARNING**

---

The external battery is not rated for use in a wet location. Do not use the external battery in a wet location.

---

## Standard Capacity Battery (N9910X-870)

**WARNING**

Lithium-ion batteries:

- Must not be exposed to high temperatures (>70°C) or fire.
- Must be kept away from children.
- Must not be short circuited.
- Must be replaced only with Keysight qualified Li-ion batteries.
- If replaced or charged improperly, there is a danger of explosion.

**WARNING**

Do not connect the positive terminal and negative terminal of the battery to each other with any metal object (such as wire).

**WARNING**

Do not carry or store the battery with necklaces, hairpins, or other metal objects.

**WARNING**

Do not pierce the battery with nails, strike the battery with a hammer, step on the battery, or otherwise subject it to strong impacts or shocks.

**WARNING**

Do not solder directly onto the battery.

**WARNING**

Do not expose the battery to water or salt water, or allow the battery to get wet.

**WARNING**

Do not disassemble or modify the battery. The battery contains safety and protection devices, which if damaged, may cause the battery to generate heat, explode, or ignite.

**WARNING**

Do not place the battery in direct sunlight, or use or store the battery inside cars in hot weather. Doing so may cause the battery to generate heat, explode, or ignite. Using the battery in this manner may also result in a loss of performance and a shortened life expectancy.

**WARNING**

There is a danger of explosion if the battery is incorrectly replaced. Replace only with the same or equivalent type of battery recommended. Discard used batteries according to manufacturer's instructions.

**WARNING**

If you are charging the batteries internally, even while the FieldFox is powered off, the FieldFox may become warm. Allow for proper ventilation.

---

**WARNING**

Do not discharge the battery using any device except the FieldFox or the external battery charger (N9910X-872). When the battery is used in a device other than those specified, it may damage the battery or reduce its life expectancy. If the device causes an abnormal current to flow, it may cause the battery to become hot, explode, or ignite and cause serious injury.

---

**WARNING**

For a Korean battery safety consideration translation, refer to [Appendix D: “Korean Battery Safety Translation.”](#)

---

**WARNING**

For a Russian battery safety consideration translation, refer to [Appendix E: “Russian Battery Safety Translation.”](#)

---

## Battery Protective Functions

This section contains the following:

- “**Battery Protective Functions (N9910X-876)**”
- “**Battery Protective Functions (N9910X-870)**” on page 813

### Battery Protective Functions (N9910X-876)

The following protective functions are designed into the lithium-ion rechargeable battery system used in FieldFox.

The protective functions can be divided between two categories: active and passive. Active protection refers to the type of protection that depends on at least two or more protection devices working together to enable the protection. Passive protection refers to the type of protection that is always enabled independent of any other protection device.

#### Active Protection

**Primary Overcharge Voltage:** This prevents the battery from being charged if the voltage across any cell exceeds approximately 4.25 V per cell. Once the overcharge protection is tripped, the voltage across each cell must drop below approximately 4.10 V to reset the protection and permit charging.

**Overdischarge Voltage:** This prevents the battery from discharging if the voltage across any cell drops below approximately 2.5 V. Once the overdischarge voltage protection is tripped, the voltage across each cell must be charged to approximately 3 V to reset the protection and permit discharging.

**Primary Overcharge Current:** This prevents the battery from being charged if the average charging current reaches or exceeds 3.3A for a time period of 5 seconds or more.

**Primary Overdischarge Current:** This prevents the battery from being discharged if the average current out of the battery reaches or exceeds 7A for a time period of 5 seconds or more. This protection can be reset by removing the load.

**Short Circuit Protection:** This prevents the battery from being charged or discharged and protects against damage or lost data if the current in or out of the battery reaches or exceeds 33.3A for a time period of 274.5 microseconds or more. This protection can be reset by removing the load.

**Overtemperature Charging:** The system microcontroller prevents the battery from being charged if the cell temperature exceeds 48C. Once the overtemperature charging protection is tripped, the cell temperature has to drop to or below 43C to reset the protection and permit charging.

**Overtemperature Discharging:** The system microcontroller prevents the battery from being discharged if the cell temperature exceeds 67C. Once the overtemperature discharging protection is tripped, the battery is automatically shut off which results in turning off the instrument as well.

#### Passive Protection

**Reverse Charging:** A reverse protection diode prevents against damage or lost data due to a reverse charge polarity applied to the battery terminals.

**Primary Overtemperature:** The maximum operating temperature of this fuse is 85C. An overtemperature cutout permanently opens at 85C with no recovery.

**Secondary Overtemperature:** A second PTC polyfuse built into each Li-ion cell will open up and limit current flow at high currents.

**Tertiary Overtemperature:** A current interrupt device (CID) within each Li-ion cell will permanently open up when an individual cell's internal pressure is too high. As each cell fuse is permanently interrupted, overall battery performance will become severely degraded, up to and including disabling the battery.

## Battery Protective Functions (N9910X-870)

The following protective functions are designed into the lithium-ion rechargeable battery system used in FieldFox.

The protective functions can be divided between two categories: active and passive. Active protection refers to the type of protection that depends on at least two or more protection devices working together to enable the protection. Passive protection refers to the type of protection that is always enabled independent of any other protection device.

### Active Protection

**Primary Overcharge Voltage:** This prevents the battery from being charged if the voltage across any cell exceeds approximately 4.35 V per cell. Once the overcharge protection is tripped, the voltage across each cell must drop below approximately 4.15 V to reset the protection and permit charging.

**Secondary Overcharge Voltage:** This is a one-time, permanent protection that is triggered when the voltage across any cell exceeds approximately 4.45 V. Once this protection is tripped, the battery can no longer be used and must be replaced.

**Overdischarge Voltage:** This prevents the battery from discharging if the voltage across any cell drops below approximately 2.6 V. Once the overdischarge voltage protection is tripped, the voltage across each cell must be charged to approximately 3 V to reset the protection and permit discharging.

**Primary Overcharge Current:** This prevents the battery from being charged if the average charging current reaches or exceeds 3.5A for a time period of 120 seconds or more.

**Secondary Overcharge Current:** This prevents the battery from being charged if the charging current reaches or exceeds 4A+/-20% for a time period of 20 milliseconds or more.

**Primary Overdischarge Current:** This prevents the battery from being discharged if the average current out of the battery reaches or exceeds 5A for a time period of 120 seconds or more. This protection can be reset by removing the load.

**Secondary Overdischarge Current:** This prevents the battery from being discharged if the current out of the battery reaches or exceeds 6A for a time period of 20 milliseconds or more. This protection can be reset by removing the load.

**Short Circuit Protection:** This prevents the battery from being charged or discharged and protects against damage or lost data if the current in or out of the battery reaches or exceeds 12.5A for a time period of 183 microseconds or more. This protection can be reset by removing the load.

**Overtemperature Charging:** The system microcontroller prevents the battery from being charged if the cell temperature exceeds 46C. Once the overtemperature charging protection is tripped, the cell temperature has to drop to or below 45C to reset the protection and permit charging.

**Overtemperature Discharging:** The system microcontroller prevents the battery from being discharged if the cell temperature exceeds 65C. Once the overtemperature discharging protection is tripped, the battery is automatically shut off which results in turning off the instrument as well.

### Passive Protection

**Reverse Charging:** A reverse protection diode prevents against damage or lost data due to a reverse charge polarity applied to the battery terminals.

**Primary Overtemperature:** A PTC (positive temperature coefficient) polyfuse in series between the Li-ion cells and the charging and discharging transistors will open up and limit current flow to the battery terminals as a function of very high currents. This protection is resettable once the overstress condition is removed.

**Secondary Overtemperature:** A second PTC polyfuse built into each Li-ion cell will open up and limit current flow as a function of very high currents.

**Tertiary Overtemperature:** A current interrupt device (CID) within each Li-ion cell will permanently open up when an individual cell's internal pressure is too high. As each cell fuse is permanently interrupted, overall battery performance will become severely degraded, up to and including disabling the battery.

**Overcurrent Fuse:** This is a one-time blow fuse with a rated current of 12A.

## Batteries: Safe Handling and Disposal

Refer to battery manufacture Safety Data Sheet (SDS) for safe handling and disposal information. Battery SDS's are located at:

<https://regulations.about.keysight.com/msds/default.htm>

## Battery Transportation

Batteries are generally subject to transportation regulations, refer to the battery Safety Data Sheet (SDS) and contact your shipping department for transportation requirements.

## Environmental Requirements

Refer to the FieldFox Specifications in **“Specifications/Data Sheet” on page 829.**

## Electrical Requirements

The FieldFox allows you to use either the lithium-ion battery or the AC/DC adapter - both are included.

## Electrostatic Discharge (ESD) Precautions

The FieldFox was constructed in an ESD protected environment. This is because most of the semiconductor devices used in this instrument are susceptible to damage by static discharge.

Static charges are generated in numerous ways, such as simple contact, separation of materials, and normal motions of persons working with the FieldFox. To prevent instrument damage, practice industry accepted techniques for handling static sensitive devices when using the FieldFox.

Very often, coaxial cables and antennas also build up a static charge, which, if allowed to discharge by connecting to the FieldFox, may damage the instrument input circuitry. To avoid such damage, it is recommended to dissipate any static charges by temporarily attaching a short to the cable or antenna prior to attaching to the instrument.

## FieldFox Markings

The table below lists the definitions of markings that may be on or with the product. Familiarize yourself with each marking and its meaning before operating the instrument.

### NOTE

**All labels and symbols may not apply to the instrument.**













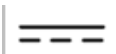



This symbol marks the standby position of the power line switch.



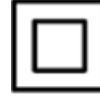







This symbol marks the ON position of the power line switch.

Safety Considerations  
FieldFox Markings

	This symbol marks the OFF position of the power line switch.
	This symbol indicates that the input power required is AC.
	This symbol indicates DC voltage
	This symbol indicates a three-phase alternating current.
	This symbol indicates Frame or chassis Terminal.
	The instruction documentation symbol. The product is marked with this symbol when it is necessary for the user to refer to the instruction in the documentation.
	This symbol indicate the presence of a Laser device.
	This symbol indicates the surface can be hot.
	This symbol indicated the product is sensitive to electrostatic discharge.
	This symbol identifies the Protective Conductor terminal.
	This symbol indicates the equipment is protected throughout by double or reinforced insulation.
	The CE mark is a registered trademark of the European Community (if accompanied by a year, it is the year when the design was proven). It indicates that the product complies with all the relevant directives.
	The UK conformity mark is a UK government owned mark. Products showing this mark comply with all applicable UK regulations.
	The Keysight email address is required by EU directives applicable to our product.
	The CSA mark is a registered trademark of the CSA International.

Safety Considerations  
FieldFox Markings

	Two person lift required.
<b>CAN ICES/NMB-001(A)</b>	Canada EMC label. Interference-Causing Equipment Standard for industrial, scientific and medical (ISM) equipment. Matériel industriel, scientifique et médical (ISM).
	CE/ICES/ISM label. (Old mark for reference only.) This is a space saver label that combines three markings - CE with CAN ICES and ISM (see above) and ISM (see below).
	This is a space saver label that combines three markings - CE with CAN ICES and ISM (see above) and ISM (see below).
	The RCM mark is a registered trademark of the Australian Communications and Media Authority.
	This is a space saver label that combines two markings - CAN ICES and ISM.
<b>ISM 1-A</b>	This is a symbol of an Industrial Scientific and Medical Group 1 Class A product (CISPR 11, Clause 5).
	South Korean Certification (KC) mark. It includes the marking's identifier code.
	The crossed-out wheeled bin symbol indicates that separate collection for waste electric and electronic equipment (WEEE) is required, as obligated by the EU DIRECTIVE and other National legislation. Please refer to <a href="http://www.keysight.com/go/takeback">www.keysight.com/go/takeback</a> to understand your trade-in options with Keysight, in addition to product takeback instructions.
	China Restricted Substance Product Label. The EPUP (environmental protection use period) number in the center indicates the time period during which no hazardous or toxic substances or elements are expected to leak or deteriorate during normal use and generally reflects the expected useful life of the product.
	Universal recycling symbol. This symbol indicates compliance with the China standard GB 18455-2001 as required by the China RoHS regulations for paper/fiberboard packaging.
<b>IP x y</b>	This mark indicates product has been designed to meet the requirements of “IP x y”, where “x” is the solid particle protection and “y” is the liquid ingress protection.

## Battery Markings

The table below lists the definitions of markings that may be on or with the product. Familiarize yourself with each marking and its meaning before operating the instrument.

**NOTE**

**All labels and symbols may not apply to the instrument.**



The CE marking is a registered trademark of the European Community (if accompanied by a year, it is the year when the design was proven). It indicates that the product complies with all relevant directives.



Eurasian Conformity Mark indicating conformance to all technical regulations of the Eurasian Customs Union.



Dispose of properly. Do not throw batteries away—collect as small chemical waste.



Recycle the old battery properly. Consult local or country regulations related to disposal.



Keep battery away from excessive heat. Do not dispose of by burning.



Taiwan recycling symbol.



The RCM Mark is a registered trademark of the Australian Communications and Media Authority.



Korean Certification (KC) mark.



India mark from the Bureau of Indian standards. IS 13252 is the equivalent India standard to IEC 60950-1.

Safety Considerations  
Battery Markings



GOST, Russia's safety and EMC mark.



The UL Marks are registered certification marks of Underwriters Laboratories Inc. (UL). It means that UL has tested and evaluated representative samples of that product and determined that it meets UL's safety requirements. When accompanied by a 'C' and 'US', it indicates compliance to both Canadian and US requirements.



Taiwan's safety and EMC compliance mark.



Indicates the time period which no hazardous or toxic substance elements are expected to leak or deteriorate during normal use. Ten years is the expected useful life of the product.

This symbol indicates the Environmental Protection Use Period (EPUP) for the product's toxic substances and for the China RoHS requirements.



The UK conformity mark is a UK government owned mark. Products showing this mark comply with all applicable UK regulations.



The CSA mark is a registered trademark of the CSA international.

**CAN ICES/NMB-001(A)**

Canada EMC label. Interference-Causing Equipment Standard for industrial, scientific and medical (ISM) equipment. Matériel industriel, scientifique et médical (ISM).

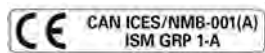

CE/ICES/ISM label. This is a space-saver label that combines three markings – CE with CAN ICES (see above) and ISM (see below).



The RCM mark is a registered trademark of the Australian Communications and Media Authority.



This is a combined marking to indicate product compliance with the Industry Canadian Interference-Causing Equipment Standard (ICES/NMB-001). This is also a symbol of an Industrial Scientific and Medical Group 1 Class A product (CISPR 11, Clause 5).











**ISM 1-A**

This is a symbol of an Industrial Scientific and Medical Group 1 Class A product (CISPR 11, Clause 5).



South Korean Certification (KC) mark. It includes the marking's identifier code.

Safety Considerations  
Battery Markings

	Universal recycling symbol. This symbol indicates compliance with the China standard GB 18455-2001 as required by the China RoHS regulations for paper/fiberboard packaging.
	This symbol marks the standby position of the power line switch.
	This symbol marks the ON position of the power line switch.
	This symbol marks the OFF position of the power line switch.
	This symbol indicates the input power required is AC.
	This symbol indicates DC voltage.
	This symbol indicates a three-phase alternating current.
	This symbol indicates frame or chassis terminal.
	This symbol indicates the presence of a laser device.
	This symbol identifies the Protective Conductor Terminal.
	This symbol indicates the equipment is protected throughout by double or reinforced insulation.

## Packaging Markings



Universal recycling symbol. This symbol indicates compliance with the China standard GB 18455–2001 as required by the China RoHS regulations for paper/fiberboard packaging.

## AC/DC Adapter Markings

The table below lists the definitions of markings that may be on or with the product. Familiarize yourself with each marking and its meaning before operating the instrument.

### NOTE

All labels and symbols may not apply to the instrument.



The UL Marks are registered certification marks of Underwriters Laboratories Inc. (UL). It means that UL has tested and evaluated representative samples of that product and determined that it meets UL's safety requirements. When accompanied by a 'C' and 'US', it indicates compliance to both Canadian and US requirements.



NOM Mark (Normality of Mexico) indicates that the product was tested by an accredited laboratory in Mexico and meets Mexico's safety requirements.



Japan's safety and EMC compliance mark.



China's safety and EMC compliance mark.















Taiwan's safety and EMC compliance mark.



Singapore's safety mark.

Safety Considerations  
AC/DC Adapter Markings

	Korean Certification (KC) mark; includes the marking's identifier code.
	GOST, Russia's safety and EMC mark.
	AC (Alternating Current).
	Direct current (DC) equipment
	CAUTION, risk of danger, refer to safety information in manual.
	DC connector polarity
	Ingress Protection Code
	Operating instructions should be considered when operating the device.
	U.S. Energy efficiency rating
	Eurasian Conformity Mark indicating conformance to all technical regulations of the Eurasian Customs Union.
	UL component mark. Recognized in Canada and the United States.
	Operation for indoors only.

Safety Considerations  
AC/DC Adapter Markings



India mark from the Bureau of Indian standards. IS 13252 is the equivalent India standard to IEC 60950-1.



IRAM/S-mark is the safety mark for Argentina.



The crossed out wheeled bin symbol indicates that separate collection for waste electric and electronic equipment (WEEE) is required, as obligated by the EU DIRECTIVE and other National legislation.

Please refer to [keysight.com/go/takeback](https://www.keysight.com/go/takeback) to understand your Trade in options with Keysight in addition to product takeback instructions.



Dispose of properly



The UK conformity mark is a UK government owned mark. Products showing this mark comply with all applicable UK regulations.



The CSA mark is a registered trademark of the CSA international.

**CAN ICES/NMB-001(A)**

Canada EMC label. Interference-Causing Equipment Standard for industrial, scientific and medical (ISM) equipment. Matériel industriel, scientifique et médical (ISM).



CE/ICES/ISM label. This is a space-saver label that combines three markings – CE with CAN ICES (see above) and ISM (see below).



The RCM mark is a registered trademark of the Australian Communications and Media Authority.

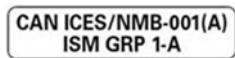

This is a combined marking to indicate product compliance with the Industry Canadian Interference-Causing Equipment Standard (ICES/NMB-001). This is also a symbol of an Industrial Scientific and Medical Group 1 Class A product (CISPR 11, Clause 5).

**ISM 1-A**

This is a symbol of an Industrial Scientific and Medical Group 1 Class A product (CISPR 11, Clause 5).













South Korean Certification (KC) mark. It includes the marking's identifier code.



Universal recycling symbol. This symbol indicates compliance with the China standard GB 18455-2001 as required by the China RoHS regulations for paper/fiberboard packaging.

Safety Considerations  
Certification and Compliance Statements

	This symbol marks the standby position of the power line switch.
	This symbol marks the ON position of the power line switch.
	This symbol marks the OFF position of the power line switch.
	This symbol indicates the input power required is AC.
	This symbol indicates DC voltage.
	This symbol indicates a three-phase alternating current.
	This symbol indicates frame or chassis terminal.
	This symbol indicates the presence of a laser device.
	This symbol identifies the Protective Conductor Terminal.
	This symbol indicates the equipment is protected throughout by double or reinforced insulation.

## Certification and Compliance Statements

### Certification

Keysight Technologies, Inc. certifies that this product met its published specifications at the time of shipment from the factory. Keysight Technologies, Inc. further certifies that its calibration measurements are traceable to the United States National Institute of Standards and Technology, to the extent allowed by the Institute's calibration facility, and to the calibration facilities of other International Standards Organization members.

## Manufacturer's Declaration

This product has been designed and tested in accordance with accepted industry standards, and has been supplied in a safe condition. The documentation contains information and warnings that must be followed by the user to ensure safe operation and to maintain the product in a safe condition.

## Declaration of Conformity

Should the Declaration of Conformity be required, visit:

<http://www.keysight.com/go/conformity>.

For more information, see **"Where to Find the Latest Information" on page 3.**

## EMC

Complies with the following standards (dates and editions are cited in the Declaration of Conformity):

- CISPR Pub 11 Group 1, class B
- AS/NZS CISPR 11
- ICES/NMB-001

This ISM device complies with the Industry Canada Interference-Causing Equipment Standard (ICES-001);  
Cet appareil ISM est conforme a la norme NMB-001 du Canada.

## Safety

Complies with the European Low Voltage Directive

- IEC/EN 61010-1
- Canada: CSA C22.2 No. 61010-1
- U.S.A.: UL std no. 61010-1

## Acoustic Statement (European Machinery Directive)

### Acoustic Noise Emission

LpA <70 dB

Operator position

Normal operation position per ISO 7779

Safety Considerations  
Certification and Compliance Statements

## Index

### Numerics

- 1-port cable loss measurements
  - CAT mode, 60
- 1-port cable loss, CAT mode, 61
- 1-Port Cable Trimming VVM Measurements, 593
- 1-Port Cable Trimming, VVM measurements, 585
- 2-port insertion loss measurements, 593
  - CAT mode, 62
- 2-port insertion loss measurements, CAT mode, 62
- 2-port transmission measurements
  - VVM mode, 595
- 2-port transmission measurements, VVM mode, 595
- 5G NR EVM Conducted features, 352
- 5G NR features, 349
- 89600 VSA software, 507

### A

- ABC keyboard, 749
- AC/DC adapter
  - markings, 821
  - power requirements, 29
  - using, 795
- AC/DC adapter markings using, 801
- accessories, 26
- Adjacent Channel Power (ACPR), 220
- Alias Faults, 73, 86
- align all now, alignments, 203
- alignments, align all now, 203
- alignments, individual, 201
- alignments, overview, 201
- all about markers, 700

- AM FM Tune & Listen, 166, 170
- AM/FM Metrics, error messages, 617
- AM/FM Metrics, Option 355, 607
- AM/FM Metrics, error messages, 617
- Amplitude Alignment, 206
  - InstAlign, 272
  - EMI, 329
  - IQA, 310, 677
  - RF Burst, 206
- Antenna Corrections, 161, 163, 640, 646
- Antenna, Option 360, 405
- appendix B, 827, 829
- attenuation, 159, 257, 303, 321
- Audio Beep, 213
- Average Type, 199, 271, 329
- Averaging
  - VVM, 590
- averaging, 54, 102, 722
  - VVM, 590
- avoid overpowering, 36

### B

- Band Power Marker IQA, 306
- Band Power Marker SA
  - mode, 211, 306, 307, 309, 714
- Band Span Marker IQA, 307
- bandpass mode, 67, 68
- battery
  - care, 798
  - charge status, viewing, 793
  - charge status, viewing, 726, 793
  - charging, 31
    - external, 797
    - internal, 795
  - disposal, 799
  - gauge, 794
  - icons, 793
  - installing, 30
  - LED, 797

- markings, 818
- maximizing life, 798
- protective functions, 811, 813
- safe handling, 814
- saver, 743
- service diagnostics, 794
- viewing charge status, 30
- Big Marker IStates, 110
- big marker states, 110
- bridge cancellation measurements, VVM mode, 595
- brightness display, 729
- Built-in Power Meter, 537

### C

- Cable (Correction) Specifications
  - DTF, 69, 81
- cable and antenna test See CAT
- cable loss measurements, 60, 61
- cable specifications, DTF, 70
- Cal On ?, 142
- Calculated DTF values, 73, 85
- calibration
  - Cal On ?, 142
  - CAT and NA modes, 125
  - noise figure, 687
  - type, 136
  - verifying integrity, 144
- Calibration Type, 136
- Calibration Wizard
  - Wizard, calibration, 687
- CalReady, 127
  - properties, 142
- CalReady Properties, 142
- Capture Data IQA, 291
- care of the battery, 798
- CAT mode
  - 1-port cable loss measurements, 60

2-port insertion loss  
   measurements, 62  
 calibration, 125  
 DTF settings, 66, 78, 91, 115, 290  
 return loss measurements, 60  
 settings, 51, 533, 534  
 CAT mode measurements, 531  
 certification statements, 824  
 Channel Power (CHP), 216  
 channel scanner, option  
   312, 621  
 Channel Selection, 155  
 charge status, viewing, 726, 793  
 charging the battery  
   externally, 797  
   internally, 795  
 cleaning the screen, 40  
 colors, display, 729  
 compliance statements, 824  
 compressed measurement, 160,  
   258  
 Compressed SA  
   Measurements, 160, 258  
 connector care review, 827  
 considerations, safety, 801  
 Contacting Keysight, 5  
 Continuous Peak Search  
   Marker IQA, 309  
 Control, Fan, 771  
 control, temperature, 33  
 Couple Markers IQA, 307  
 Coupled Frequency, 58, 68  
 Coupled Markers, 703  
 cursor moving, 789  
 cursor, moving, 781, 789, 791

**D**

data analysis features, 699, 777  
 data indicator (\*), old, 214  
 data indicator, old (\*), 214  
 Data Logging, 394  
 Date and Time Setting, 763  
 Date and Time setting, 746  
 date/time setting, 746, 762  
 declaration of conformity, 825  
 delta marker, 701, 702  
 delta markers, 701  
 Detection Method, 208, 270, 330  
 detection method, 208, 270, 330  
 display  
   brightness, 729

colors, 729  
 front panel, 44  
 preferences, 742  
 settings, 729  
 display "live" and memory  
   traces, 584  
 Display Resolution  
   VVM, 588  
 disposal of battery, 799  
 dissipate static charge, 37  
 DTF  
   measurements, 63, 64  
   settings, 66, 78, 91, 115, 290  
   start and stop distance, 64  
 DTF Measurement, 66, 78  
 DTF settings, 66  
 DTF Start and Stop  
   Distance, 67, 79  
 Dynamic Range, 112  
 dynamic range, 112

**E**

ECal, 131  
 Edit a Cable File, 70  
   DTF, 70, 82  
 edit keywords, 789  
 edit, enable and disable the  
   current prefix, 789, 791  
 edit, enable and disable the  
   current suffix, 789, 790  
 Electrical Delay, 101  
 Electromagnetic  
   Interference, 313  
 EMF  
   measurements, how to  
     make, 390  
     set up, 387  
   settings, 226, 387, 732  
 EMF Settings, 226  
 EMI  
   measurements, about, 332  
 EMI Glossary, 335  
 EMI mode  
   settings, 334  
   units, 320  
 EMI Mode Units, 320  
 Enhanced Response  
   Optimization, 141  
 Erase User Data, 769  
 error  
   meas UNCAL, 183, 184, 214

red flashing LED, external  
   battery charger, 797  
 red red flashing LED, external  
   battery  
   charger, 797  
   systematic, 126  
 error messages, AM/FM  
   Metrics, 617  
 Error messages, fan, 772  
 ERTA, 597  
 ESD, 815  
 Event Log, 769  
 external frequency  
   reference, 760  
 External Gain, 158, 256, 320  
 External triggering, 105, 192, 264  
 external triggering, 192, 264  
 external zeroing, 547

**F**

Fan Control, 771  
 Fan, error messages, 772  
 features, 5G NR, 349  
 features, 5G NR EVM  
   Conducted, 352  
 features, overview, 25  
 FFT Gating, 196  
 Field Strength  
   Measurements, 161, 640  
 File Management, 777  
 file management, 777  
 files  
   managing, 786  
   prefixes, 789, 791  
   suffixes, 789  
 FM Tune & Listen, 166, 170  
 FM tune and listen, 43  
 folders, 788  
 Format  
   NA Mode, 98  
 format, NA mode, 98  
 FoxTrot, 597  
 FreqMaskTrigger, 525  
 frequency  
   context, setting, 673  
   external reference, 760  
   mode, DTF, 67  
   range, NA mode, 99  
   range, setting, 53, 673  
   range, step size, 153  
   step size, 153

- Frequency Counter at SA
  - Marker, 212, 714
- frequency extender
  - settings, 732
  - viewing and changing, 733
- Frequency Offset Using Power
  - Sensor, 557
- Frequency Range
  - NA Mode, 99
- front panel, 38
- Full Screen Mode, 731
- G
- Gating, 122
- gating, 122
- Gating, FFT, 196
- gauge, battery, 794
- getting started information, 29
- glossary,EMI, 335
- glossary,OTA, 400
- GPS, 746
- group delay, 98, 99
- H
- high-temperature
  - protection, 32
- hold, 726
- how to
  - change
    - frequency step size, 151, 153, 254, 318
    - units to feet, 73, 85
  - check for a compressed measurement, 160, 258
  - control the preamp, 160, 258, 304, 323, 326
  - create
    - delta marker, 702
    - markers, 700
  - edit keywords, 789
  - edit, enable and disable the current prefix, 791
  - enter
    - numeric values, 46
  - make
    - 1-port cable loss measurement, 6, 61
    - 2-port insertion loss measurement, 6
    - DTF measurements, 64, 76
  - manage files, 786
  - measure return loss, 60
  - monitor the internal FieldFox temperature, 32
  - move
    - cursor, 781, 791
    - reference marker, 702
  - name files, 780
  - perform
    - O, S, L cal, 129
    - O,S, L cal, 129
    - single sweep while in Hold, 726
  - preset, 727
  - recall an \*.sta file, 782
  - save
    - display settings as preferences, 742
    - file, 778
  - select
    - CAT mode, 51, 534
    - CAT mode measurements, 51, 534
    - EMI mode, 318
    - NA formats, 98
    - RTSA mode, 254
    - SA mode, 151, 254
  - set
    - attenuation, 159, 257, 303, 321
    - bandpass mode ON, 68
    - date and time, 762
    - frequency context, 673
    - frequency range, 53, 151, 254, 318, 319, 673
    - output power, 57, 107, 590
    - power meter display units, 550
    - res BW, 182, 263, 326, 677
    - resolution, 56, 104
    - scale, 53, 722
    - sweep time, 56
    - sweep type, 55, 104
  - trace averaging, 54, 722, 723
  - video BW, 183, 184
  - use
    - external reference, 760
  - view and change Quick Settings, 97
  - view and change quick settings, 96
- How to set a Band
  - CISPR, 323
- How to set a Traces
  - EMI, 328
- http
  - //literature.cdn.keysight.com/litweb/pdf/5991-4913EN.pdf, 614
- I
- icons, battery, 793
- IF Bandwidth
  - NA Mode, 103
  - VVM, 589
- IF bandwidth
  - NA Mode, 103
- IF Output, 185
- IF output, 185
- indicator (\*), old data, 214
- individual,alignments, 201
- initial use, preparing for, 29
- input voltages and power, maximum, 36
- insertion loss
  - measurements, 62
- InstAlign, 206, 272, 310, 329, 677
- installing battery, 30
- Interference Analyzer, 513
- interference rejection, 58
- Interpolation, 142
- Interval Power Marker, 211, 306, 307, 309
- Interval Power Marker IQA, 306
- Interval Span Marker IQA, 307
- IQ Analyzer, 285
- IQA
  - markers,using, 305
  - measurement,parameters, 29, 4
  - measurements,about, 289
  - measurements,how to make, 290

- trace display states, 310
- IQA mode
  - settings, 290
- IQA, Captrure Data, 291
- Isolation, 139

## K

- Keyboard,ABC, 749
- Keyboard,Qwerty, 749
- keywords, 789

## L

- LAN Settings, 764
- language, settings, 743
- latest information, where to find, 27
- LED
  - battery, 797
  - on/off settings, 32
- Licensing, 754
- Limit Lines, 715
- Limit lines, 715
  - saving and recalling, 718
- lithium-ion battery, installing, 30
- logging, data, 394

## M

- Magnitude Offset, 100
- magnitude offset, 100
- Manage Files, 786
- Manage Folders, 788
- managing
  - files, 786
  - folders, 788
- manuals, 27
- mapping
  - settings, 732
- Mapping mode
  - settings, 471, 474
- Mapping, Option 352, 457
- Mapping,Record/Playback, 494
- marker
  - table, 702
- markers, 700
  - Coupled (NA Mode), 703
  - creating, 700
  - delta, 701
  - moving, 700

- search function, 704, 706
- table, 702
- trace, 704
- trace (CAT & NA Mode), 704
- trace (SA Mode), 704

- markers,using

- IQA, 305

- markings

- AC/DC adapter, 821
- battery, 818
- FieldFox, 815
- packaging, 821

- math

- operations, 721

- maximizing battery life, 798

- maximum input voltage and power, 36

- Meas UNCAL error, 214

- meas UNCAL error, 183, 184

- measurement selection, EMI Mode, 313

- measurement selection, IQA Mode, 285

- measurement selection, Mapping Mode, 457

- measurement selection, NA Mode, 89

- measurement selection, OTA Mode, 337

- measurement selection, Phased Array Antenna Mode, 405

- measurement selection, USB antenna Mode, 445

- measurement,parameters IQA, 294

- Measurements

- EMI, 332

- IQA, 289

- OTA, 342

- PAA, 408

- Phased Array Antenna, 408

- USB antenna, 449

- measurements

- 1-port cable loss measurements, CAT mode, 60

- 1-port cable loss, CAT mode, 60

- 2-port insertion loss, CAT mode, 62

- bridge cancellation, VVM mode, 595

- compressed, 160, 258

- return loss, 60

- selection, 51, 534

- selection, reflection, 534

- measurements,about

- EMI, 332

- IQA, 289

- OTA, 342

- Phased Array Antenna, 408

- USB antenna, 449

- measrements,how to make

- EMF, 390

- IQA, 290

- Mapping, 471

- OTA, 353

- PAA, 417

- USB antenna, 229, 451

- mini-USB port, sending SCPI

- commands, 775

- Mixed-Mode S-Parameters, 92

- mixed-mode S-parameters, 92

- mode, 507

- EMI, 313

- IQA, 285

- Mapping, 457

- NA, 89

- OTA, 337

- Phased Array Antenna, 405

- power meter, 537

- RTSA, 254

- SA, 147, 151, 251, 513, 531, 541, 557

- temperature control, 33

- USB antenna, 445

- VVM, 585

- move

- cursor, 781, 789, 791

- reference marker, 702

- moving the cursor, 781, 789, 791

- multiplier abbreviations, 46

- multipliers, 46

- Multi-Trace Configurations, 95

- multi-trace configurations, 95

## N

- NA Factory Cal, 769

- NA mode

- calibration, 125

- settings, 91, 94, 96

name files, 780  
network analyzer, 89  
noise figure, calibration, 687  
noise figure, option 356, 649  
Noise Marker IQA, 305  
normalization, 135  
normalize, 135  
numeric values, 46  
numeric values, entering, 46

## O

O, S, L cal, 129  
O, S, L calibration, 129  
Occupied Bandwidth, 218  
old data indicator (\*), 214  
Opt 010, 113  
option  
  010, 113  
  215, 75  
option 312, channel scanner, 621  
Option 352, Mapping, 457  
Option 355 AM/FM Metrics, 607  
option 356, noise figure, 649  
Option 360, Antenna, 405  
options  
  installing, 754  
OTA  
  measurements,about, 342  
  measurements,how to make, 353  
OTA Glossary, 400  
OTA mode  
  settings, 353  
OTA troubleshooting, 399  
Output Power  
  NA Mode, 107, 589  
output power, 57, 107, 590  
overpowering, avoid, 36  
Over-The-Air, 337  
overview, 25  
overview,alignments, 201

## P

PAA  
  settings, 417, 732

PAA mode  
  settings, 417  
packaging markings, 821  
panel, front, 38  
panel, left side, 43  
panel, right side, 42  
panel, top, 41  
Parameter Conversion, 93  
peak  
  criteria, 711  
  excursion, 711, 712  
  threshold, 711  
perform  
  single sweep while in Hold, 726  
Phase Offset, 101  
Phased Array Antenna  
  measurements,about, 408  
phased array antenna  
  settings, 732  
Phased Array Antenna mode  
  settings, 417  
Phased Array  
  Antenna,Record/Playback, 438  
Playback Configuration, 280, 283, 397, 441, 500, 523, 527  
Points EMI mode, 328  
Points SA mode, 198, 268, 676  
points, EMI mode, 328  
points, RTSA mode, 268  
points, SA mode, 198, 676  
Port Extensions, 108  
power meter mode, 537  
power requirements, 29  
power requirements for the AC/DC adapter, 29  
power sensor input, 42  
Power Spectral Density, 217, 239  
power, maximum, 36  
Preferences, 740  
preferences, 740  
prefixes for file names, 789, 791  
preparing for initial use, 29  
preset, 727  
preset settings, 727  
Printing, 792

printing, 792  
protection, high  
  temperature, 32  
protective functions of the battery, 794  
Pulse Measurements, 567

## Q

Quick Settings, 97  
quick settings, 52  
Qwerty keyboard, 749

## R

Radio Standard, 153  
real-time spectrum analyzer  
  mode, 251  
recall an \*.sta file, 782  
recalling files, 782  
Receiver Measurements, 94  
Record Source, 282, 526  
Record/Playback, 276, 519  
Record/Playback,Mapping, 494  
Record/Playback,Phased Array Antenna, 438  
Record/Playback,RTSA, 276, 394  
Record/Playback,SA, 519  
Recording Configuration, 281, 396, 440, 500, 523  
reference marker, 702, 713  
reference, external  
  frequency, 760  
Reflection Mode, 531  
remote server, 507  
resolution, 44, 56  
  NA Mode, 104  
Resolution Bandwidth EMI mode, 326  
Resolution Bandwidth SA mode, 182, 263, 677  
resolution bandwidth, EMI mode, 326  
resolution bandwidth, NF mode, 677  
resolution bandwidth, RTSA mode, 263

- resolution bandwidth, SA
    - mode, 182
  - Resolution, NA mode, 104
  - Response Cals, 134
  - response calcs, 134
  - Restart, 198, 267, 327, 676
  - restart, 198, 267, 327, 676
  - return loss measurements, CAT
    - mode, 60
  - review connector care, 47
  - reviewconnector care, 827
  - RRC Weighting, 224
  - RTSA, 251
  - RTSA mode
    - settings, 254
    - units, 255
  - RTSA, Spectrogram
    - Display, 274
  - RTSA,Record/Playback, 276, 394
  - RTSA,Spectrogram
    - Display, 274
  - RTSA,spectrogram display, 274
- S**
- S11 measurements, NA
    - mode, 91, 94
  - SA mode
    - settings, 151, 254, 274, 514
    - units, 157
  - SA Mode Units, 157, 255
  - SA,Record/Playback, 519
  - SA,spectrogram display, 514
  - Safety Considerations, 801
  - save
    - display setting as preferences, 742
    - file, 778
  - save and recalling files, 778
  - Save Preferences, 742
  - Scale Settings
    - NA Mode, 99
  - scale settings, NA mode, 99
  - scale, setting, 53, 722
  - screen cleaning, 40
  - screen front panel, 44
  - Security Level, 762
  - select
    - language, 743
  - sending SCPI commands,
    - mini-USB port, 775
  - sensors,LAN
    - Troubleshooting, 554
  - service diagnostics, 769
  - Sessions, 276, 519
  - set
    - date and time, 746
    - display colors, 729
    - display units, 550
    - output power, 589
  - set up,EMF, 387
  - settings
    - CAT mode, 51, 533, 534
    - CISPR, 321
    - DTF, 66, 78, 91, 115, 290
    - DTF mode, 66
    - EMF, 226, 387, 732
    - EMI, 334
    - frequency extender, 732
    - language, 743
    - Mapping, 471
    - mapping, 732
    - OTA, 353
    - PAA, 417, 732
    - phased array antenna, 732
    - preset, 727
    - RTSA mode, 254
    - SA mode, 151, 254, 274, 514
    - spectral emission mask, 732
    - USB antenna, 451
    - USB antennas, 732
    - VVM mode, 588
  - Settings, EMF, 226
  - settings,how to set up
    - Mapping, 474
  - smoothing, 55
  - Source Control with USB
    - Power Meter, 548
  - S-parameters, 91
  - spectral emission mask
    - settings, 732
  - Spectrogram Display, 274, 514
  - Spectrogram Display,
    - RTSA, 274
  - Spectrogram Display,RTSA, 274
  - spectrogram display,RTSA, 274
  - spectrogram display,SA, 514
  - spectrum analyzer mode, 147, 251, 513, 531, 541, 557
  - Spectrum Emission Mask (SEM) - (SA Mode Only), 238
  - stand-by mode, 31
  - Startup Mode, 744
  - static charge, dissipate, 37
  - Step Detection Mode, 552
  - suffixes for file names, 789
  - sweep
    - acquisition parameter, 184, 185, 189, 327
    - time, 56
    - time, NA mode, 105
    - type, 55, 104
    - type, EMI mode, 185, 327
    - type, SA mode, 184
  - Sweep Acquisition, 188
  - sweep acquisition, 188
  - Sweep Time
    - NA Mode, 105
  - Sweep Type
    - EMI Mode, 185, 327
    - SA Mode, 184
  - system configuration
    - settings, 754
  - System Impedance (Z0), 108
  - System Settings, 725
  - systematic, 126
- T**
- TDR, 75
  - temperature control mode, 33
  - Time Domain, 113
  - time domain, 75
  - Time Zone, 746, 763
  - time zone, 746
  - time/date setting, 746, 762
  - title, editing, 730, 731, 780
  - top panel, 41
  - trace averaging, setting, 54, 723
  - Trace Display States, 198, 269, 310, 328
  - trace display states
    - IQA, 310
  - Trace Math, 565, 720
  - Trace Width, 730, 742
  - Tracking Generator, 181, 326
  - Transform, 113
  - transform, 116
  - Transform Window, 118
  - transform window, 118
  - triggering - RTSA mode, 264
  - Triggering - SA Mode, 192, 264
  - triggering - SA mode, 105, 192
  - TRL, 138
  - troubleshooting

sensors,LAN, 554  
troubleshooting,OTA, 399  
Tune & Listen (AM/FM), 166, 170

## U

units, changing, 73, 85  
units, DTF, changing, 73  
USB antenna, 445  
  measurements,about, 449  
  measurements,how to  
  make, 229, 451  
  settings, 451  
USB antenna mode  
  settings, 226, 451  
USB antennas  
  settings, 732  
USB keyboard, 26  
use  
  external reference, 760  
User Preset, 727  
User Tags, 278, 521  
utilities, 732

## V

values  
  multipliers, 46  
  numeric, 46  
values, multipliers, 46  
VBW, 183, 184  
vector voltmeter, 585  
vector voltmeterSeeVVM, 585  
Velocity Factor, 69, 109  
verifying integrity of  
  calibration, 144  
  jumper cables, 144  
verifying integrity of calibration  
  & jumper cables, 144  
video bandwidth, 183, 184  
Video Bandwidth SA mode, 183  
Video triggering, 105, 192, 264  
video triggering, 192, 197, 264  
viewing  
  charge status, battery, 726,  
  793  
  installed options, 742, 754  
viewing and changing  
  frequency extender, 733  
Volume Control, 728  
volume control, 728  
VSA, 507

vsa, 507  
VVM Calibration, 591  
VVM mode, 585  
  bridge cancellation  
  measurements, 595  
  settings, 588  
VVM mode, settings, 588

## W

Waterfall Display, 514, 517  
Waveguide Calibrations, 139  
where to find the latest  
  information, 27  
Window Settings  
  DTF, 72, 84  
window settings, DTF, 72

## Z

zero span, 190, 191  
Zeroing VVM mode, 591  
zeroing, external, 547  
zeroing, VVM mode, 591

Index







This information is subject to change without notice.

© Keysight Technologies 2014-2021

Edition 4, December 2021



N9938-90003

[www.keysight.com](http://www.keysight.com)