

N7015A

Type-C Test Fixtures

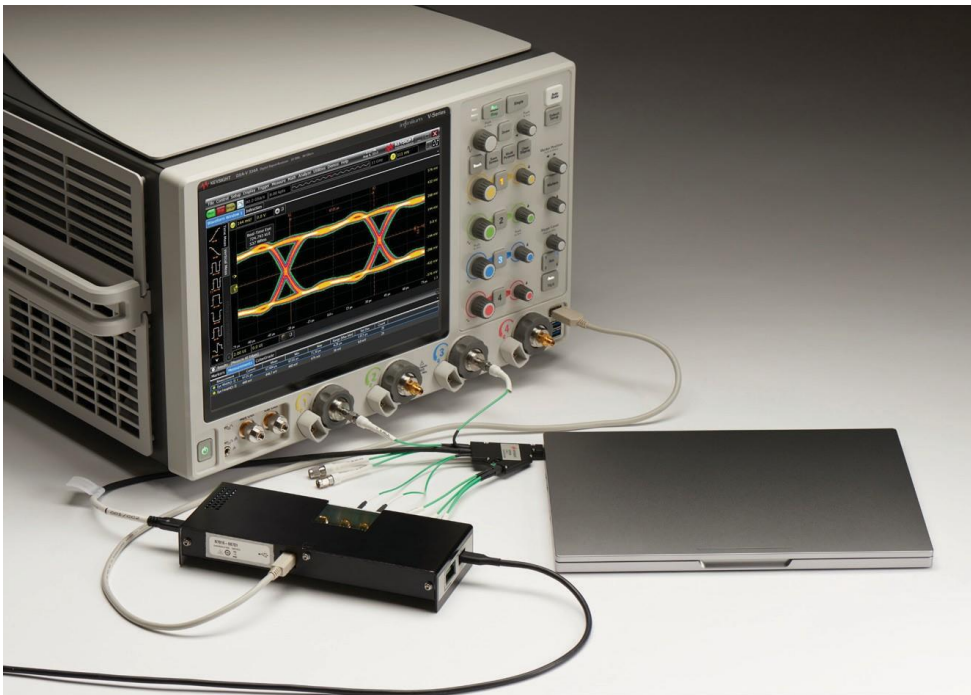

- 20 GHz bandwidth (at -3 dB), de-embeddable up to 30 GHz
- Enables signal verification and debug of USB 3.1, DisplayPort 1.3, Thunderbolt 2/3
- Has test point and probing access for transmitter and power delivery measurements
- Provides the elements to seamlessly leverage the Keysight Technologies, Inc. portfolio of compliance test applications
- Compatible with Infiniium 90000 X-Series, V-Series, Z-Series and discontinued Q-Series oscilloscopes

Industry's Highest Signal Integrity Type-C Fixture

Get the most accurate measurements with the best signal integrity

The N7015A Type-C high-speed test fixture provides best-in-class performance up to 30 GHz of de-embedtable bandwidth, enabling signal verification and debug of USB 3.1 Gen 2 designs and other high-speed signal standards to support the Type-C connector.

The N7015A Type-C high-speed test fixture breaks out four differential lanes of high-speed protocol signals to an oscilloscope, and passes low-speed power and control lines to a secondary fixture. The flexible fixture combination enables signal accessibility and probing to a Type-C design that has a receptacle (for example, a USB 3.1 upstream or downstream facing port).

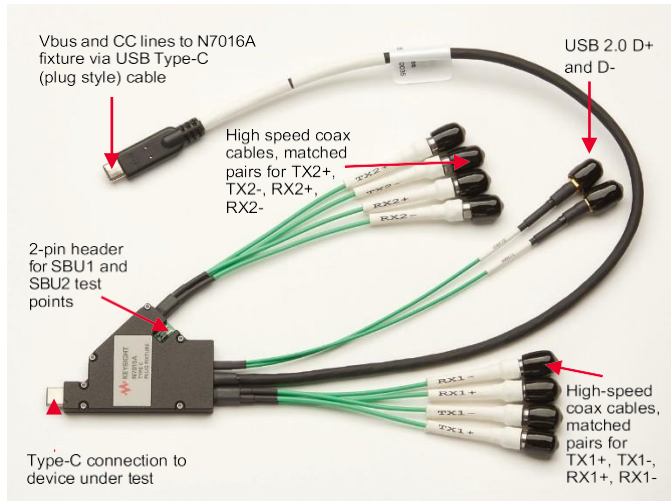

Figure 1. N7015A Type-C high-speed fixture.

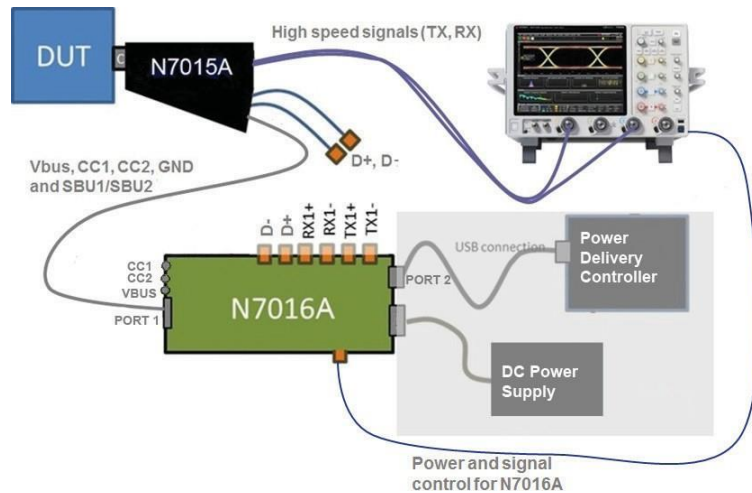

Figure 2. High-level test setup for Type-C connector.

As data rates increase, the effects of test fixtures and cabling during testing become a significant source of signal loss and impair accurate measurement of device performance. So, for accurate signal characterization in many high-speed compliance tests, de-embedding techniques are used to removing the effects of a test fixture from measurements to obtain the actual performance of the DUT. Best performance in overcoming the losses is achieved when the channel (in this case, the test fixture)

is designed with minimum loss and care is taken in the characterization of the fixture through measurement of S-parameters. The N7015A is designed for the best signal integrity, and S-parameter models are available from Keysight that can be used in Keysight's Infiniium baseline software and industry's broadest portfolio of compliance test applications, including USB, DisplayPort, and Thunderbolt.

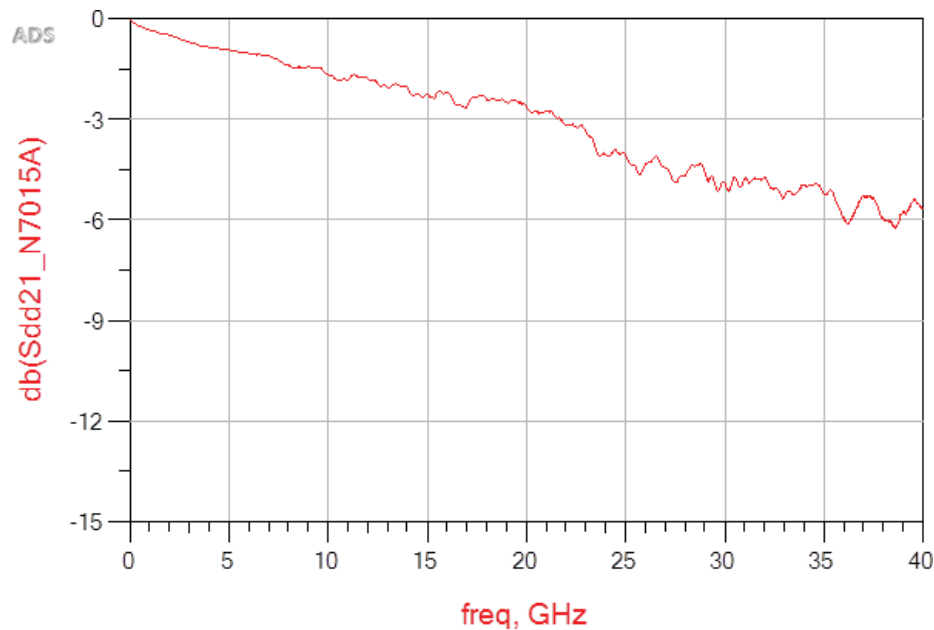

Figure 3. N7015A insertion loss (22 GHz at -3 dB).

Protect your investment with a robust and usable solution

The N7015A fixture is reversible, when used in conjunction with the N7016A, meaning the plug can be flipped 180 degrees and will still allow testing, without any damage or error. Its unique design allows two fixtures to be used side-by-side and/or top-to-bottom.

Whether connected side-by-side or stacked, the fixtures meet the minimum spacing allowed for in the specification. Durable fixture design ensures multiple connections and disconnections without failure in an active test environment.

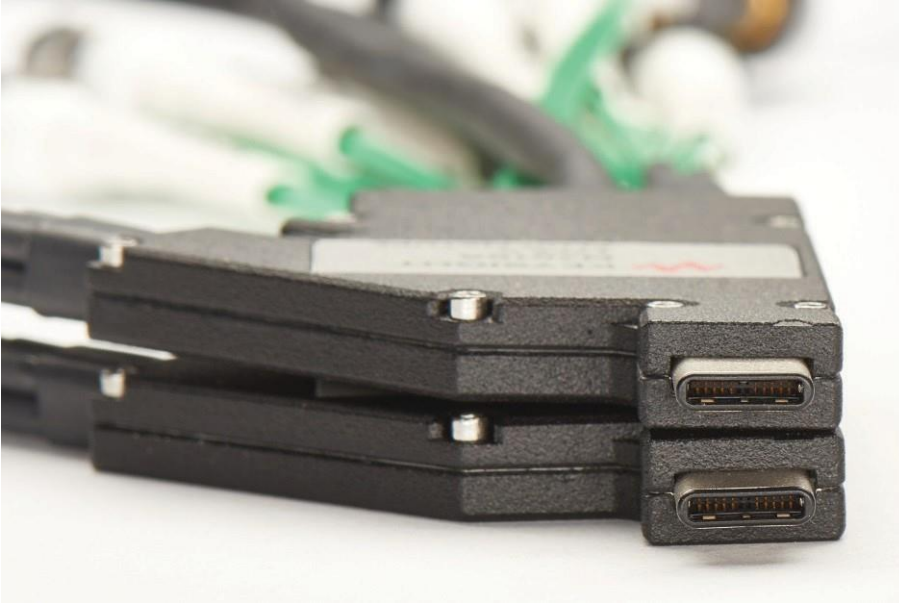

Figure 4. N7015A comes with a form factor to fit two fixtures top-to-bottom.



Figure 5. N7015A comes with a form factor to fit two fixtures side-by-side.



Figure 6. Use the E2678B socketed head with InfiniiMax I/II probe amp to probe D+/D- signals.

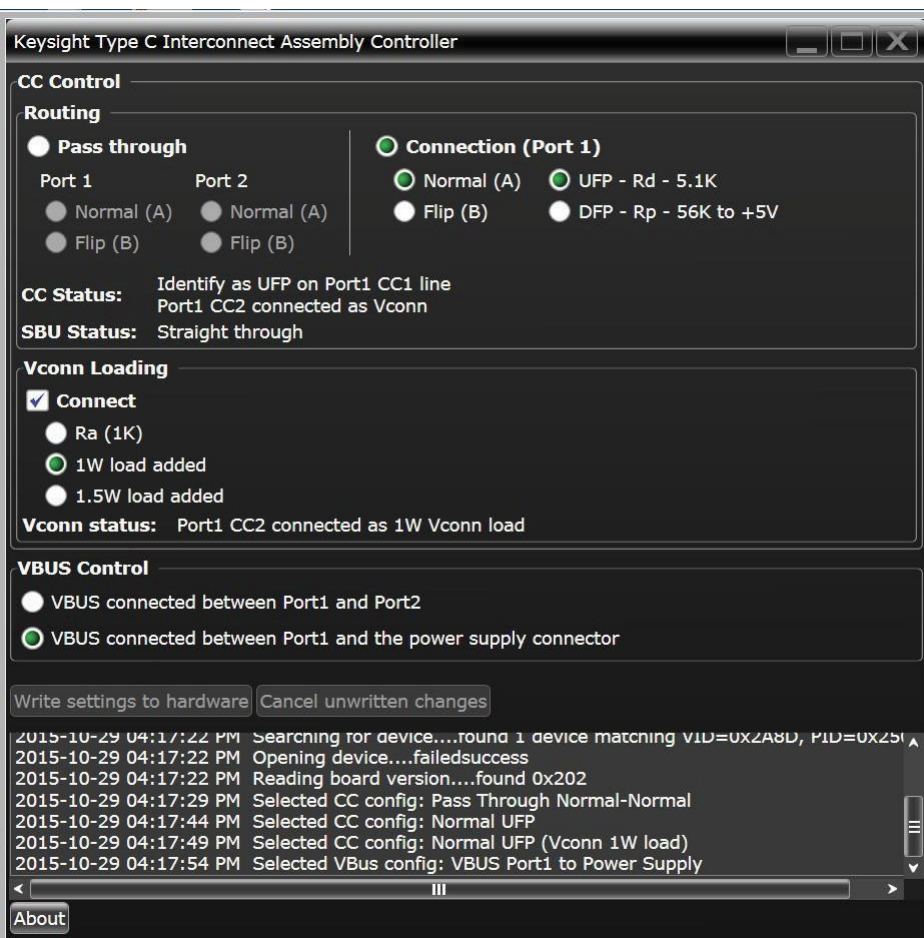

Figure 7. The controller software enables you to route CC lines with or without loading and V_{bus} through the interconnect assembly.

Reduce test time with a configurable system

The N7015A Type-C fixture solution can be a fully automated power delivery management system with a third-party power delivery controller.

Environmental and safety characteristics

Temperature	Operating: 0 to +55 °C Non-operating: -40 to +70 °C
Humidity	Operating: Up to 95% RH at or below +40 °C; up to 80% RH up to +65 °C Non-operating: Up to 90% RH up to 65 °C
Altitude	Operating: Up to 4,600 m (15,000 ft) Non-operating: 4,600 m
Safety	IEC 61010-1:2010 / EN 61010-1:2010 (3rd Edition)

Ordering Information

Model numbers	Description
N7015A	Type-C high-speed test fixture, includes wrench

Other Recommended Probes and Accessories

Model numbers	Description
1130A	InfiniiMax 1130A 1.5 GHz probe amplifier
E2678B	Socketed probe head for InfiniiMax I/II amp
N2871A	200 MHz 10:1 passive probe
N2823A	Cable assembly, coax phase matched pair, 1 m, 2.92 mm (m) to 2.92 mm (m)
N5448B	Cable assembly, coax phase matched pair, 25 cm, 2.92 mm (m) to 2.92 mm (m)
11904B	Test port adapter for connecting 2.4 mm (m) to 2.92 mm (m)
11742A	DC blocking capacitor
83059B	Coax connector saver adapter, 3.5 mm (f) to 3.5 mm (f)
N2787A	3D probe positioner
8710-1765	Torque wrench, 8 lbs, 5/16 inch (for connecting N7015A to the scope input)



www.keysight.com/find/USBTypeC

Learn more at: www.keysight.com

For more information on Keysight Technologies' products, applications or services, please contact your local Keysight office. The complete list is available at: www.keysight.com/find/contactus

