

Y1160A EIA Rack Sliding Shelf Installation Note

This installation note contains procedures for mounting L4400 Series LXI instruments in EIA rack cabinets using the Y1160A sliding shelf rack mount kit. The kit allows you to flush, recess, or reverse-mount up to two L4400 instruments per shelf while occupying one EIA rack unit of space.

Rack Mount Kit Contents

The contents of the Y1160A sliding shelf rack mount kit are listed in Table 1.

Table 1. Y1160A Rack Mount Kit Contents.

Item	Description	Part Number	Quantity
1	M4x8 flat head screw	1515-1367	12
2	10-32 pan head dress screw	0570-1577	4
3	10-32 x 0.625 pan head screw	2680-0105	10
4	10-32 x 0.5 flat head screw	2510-0283	2
5	10-32 clip-on nut	0590-0804	12
6	10-32 nut w/lock washer	2740-0003	4
7	Sliding shelf	5180-0102	1
8	Shelf rails	5180-0103	2
9	Filler panels	5180-0104	2
10	Rear (rail) brackets	5180-0105	2

Procedure

Figure 1 is a composite drawing of the Y1160A sliding shelf rack mount kit. The drawing shows the location/usage of the hardware items listed in Table 1.

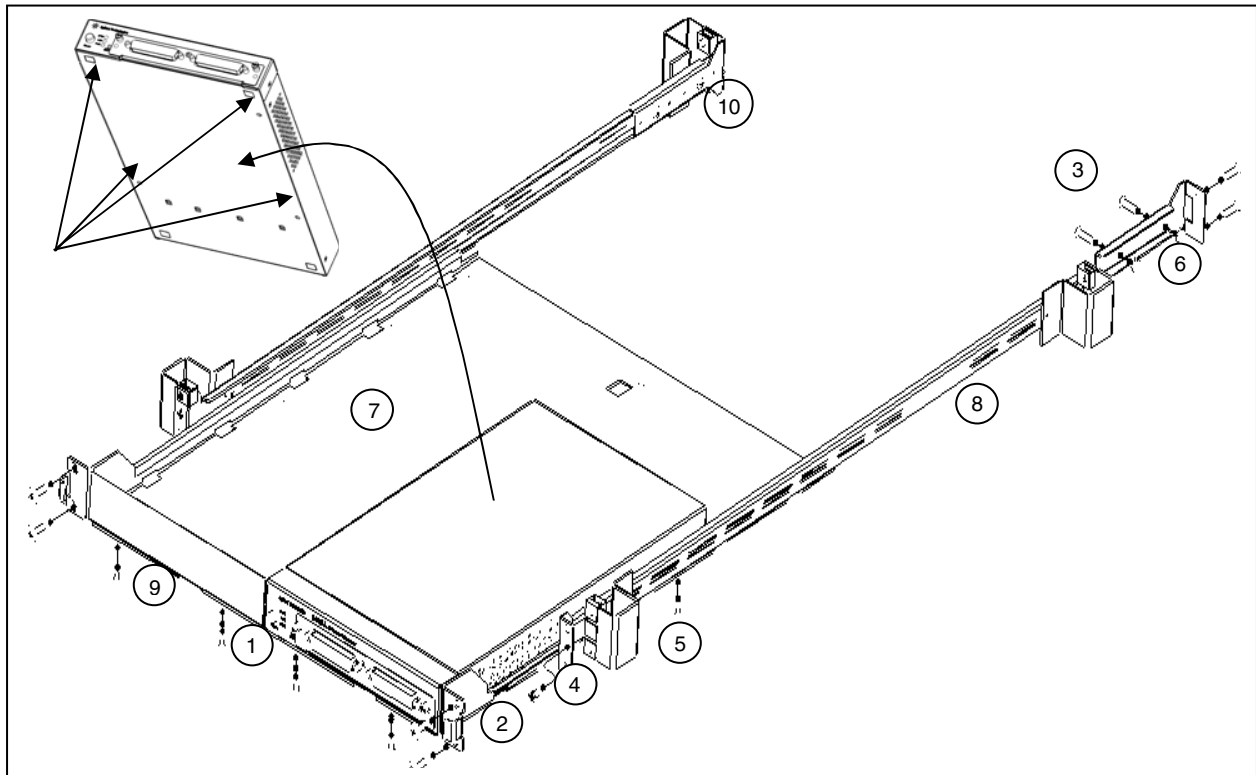

Figure 1. Y1160A Instrument Rack Mount Kit.

The L4400 series instruments can be mounted between any two adjacent EIA unit indicators (Figure 2). On Agilent racks, an EIA unit indicator is represented by a triangle (\blacktriangleright) on the rack's front and rear-facing columns. A single EIA unit extends from the triangle indicator to the next indicator on the column (1 Unit = 44.45 mm = 1.75 in).

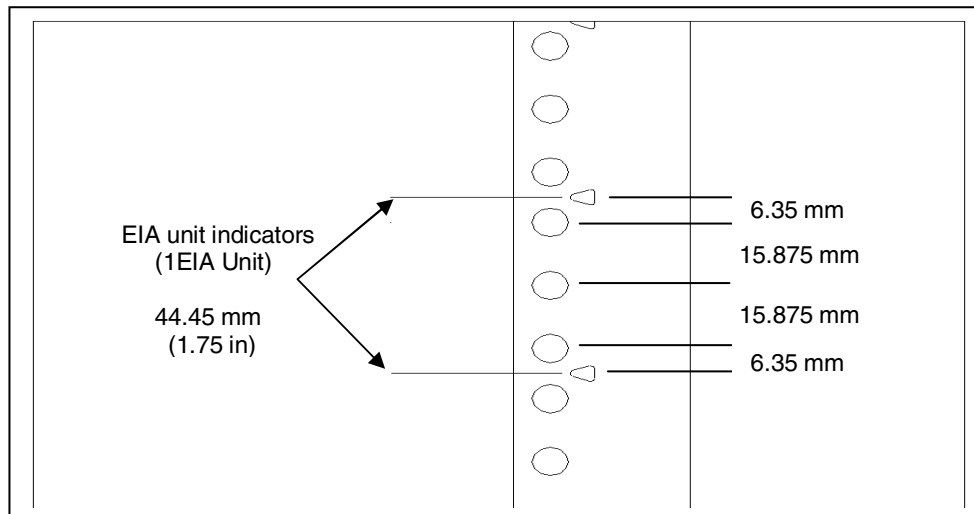

Figure 2. EIA Unit Indicators for Installing the Y1160A Rack Mount Kit.

It is not necessary to remove the cabinet side panels to rack mount the L4400 instruments. The side panels can be removed, however, if additional access to the cabinet's vertical columns is desired.

Install the Shelf Rails

1. Select the vertical position in the rack between any two adjacent EIA unit indicators where the L4400 instrument is to be installed. Insert clip-on nuts (item 5) on the three holes between the unit indicators. Place nuts on both the left and right front-facing columns (Figure 3).

If center-facing columns with holes are present on the frame, insert a clip-on nut on the hole perpendicular to the center hole on the front facing column. See Figure 3.

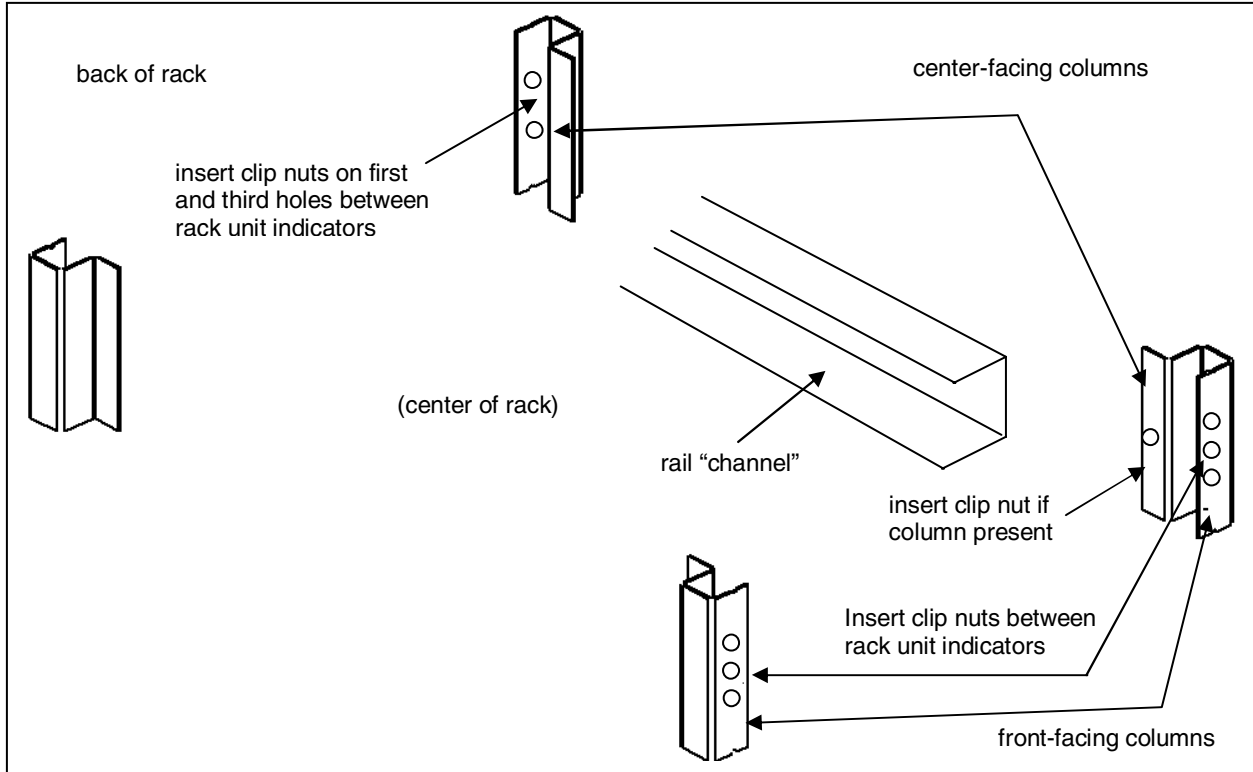

Figure 3. Rack Column and Shelf Rail Orientation.

2. With the rail "channel" facing the center of the rack, connect the rail (item 8) to the front facing column using a 10-32 flathead screw (item 4) and the center clip-on nut on the front-facing column. Repeat for the rail on the opposite column. Ensure the rail channel faces the center of the rack.

If the rack has center-facing columns (Figure 3), insert a 10-32 pan head screw (item 3) through the rail opening and clip nut (perpendicular to the front-facing column). Repeat for the rail on the opposite column.

3. On the rack's rear-facing columns, insert clip-on nuts on the first and third holes between the EIA unit indicators that are at the same vertical position as the indicators on the front-facing columns.

4. Attach the rear brackets (item 10) to the rail ends using two 10-32 pan head screws (item 3) and two 10-32 nuts with lock washers (item 6) per rail. Adjust the bracket along the rail until the bracket end aligns with (covers) the rack's rear-facing columns. Tighten the 10-32 pan head screws to firmly connect the bracket to the rail and maintain the rail length.

Connect the rail brackets to the rear-facing columns using two 10-32 pan head screws per column.

Install the Sliding Shelf

Facing the rack, slide the shelf (item 7) onto the bottom surfaces of the rail channels. The tabs at the back of the shelf pass underneath the channel surface (Figure 4). The tabs allow you to extend the shelf from the cabinet, providing a working surface for mounting the instruments.

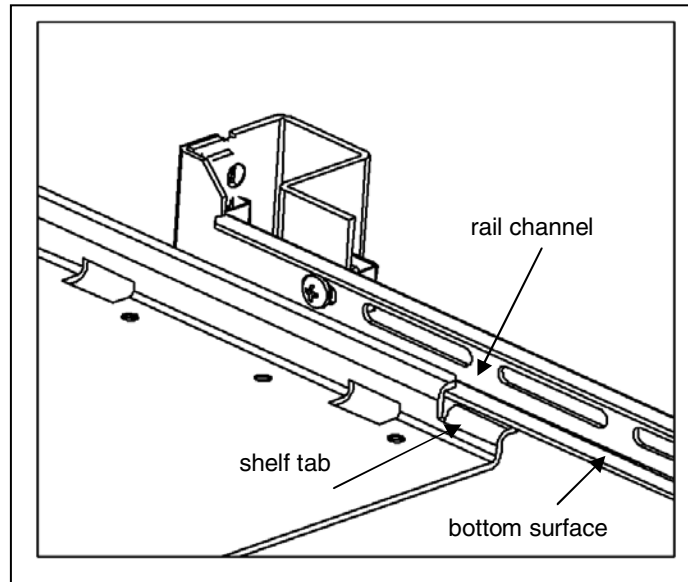

Figure 4. Installing the Sliding Shelf.

Install Instruments on the Shelf

The L4400 instruments can be installed flush (even) with front edge of the shelf, recessed in 50 mm increments, or reverse-mounted with the front of the instrument facing the back of the rack cabinet.

1. Extend the shelf from the rack such that approximately 50% - 75% of the shelf surface is outside of the rack. (The tabs on the back of the shelf that run underneath the rail channel prevent the shelf from tipping.)
2. Determine the position of the instruments (flush, recessed, reversed). To accommodate the terminal blocks (available with some L4400 instruments) and to simplify cable routing, it is recommended that the instruments be mounted flush (even) with the front or back edge of the shelf.
3. Note the location of the mounting holes on the bottom of the instrument (Figure 1). If present, remove the adhesive feet from the instrument. Place the instrument on the shelf and align the mounting holes with the holes on the shelf. Insert four M4x8 flat head screws (item 1) upward through the bottom of the shelf and into the mounting holes.
4. Install the second instrument (if present) in the shelf area adjacent to the first instrument. If only one instrument is installed, install a filler panel (item 9) on the front edge of the unused area. Insert two M4x8 flat head screws (item 1) upward through the bottom of the shelf and into the panel.
5. Connect the instrument power cord, LAN cable, and GPIB cable (if applicable).
6. For instruments that have accompanying terminal blocks, partially remove the instrument sub-assembly from the instrument (carrier) by loosening the spring-loaded mounting screws (Figure 5). Remove the support sleeve from the terminal block. Locate and remove the flat head screws from the sleeve and

remove the pan head screw from between the instrument's D-sub connectors. Connect the sleeve to the instrument using the flat head and pan head screws as shown. Reconnect the sub-assembly.

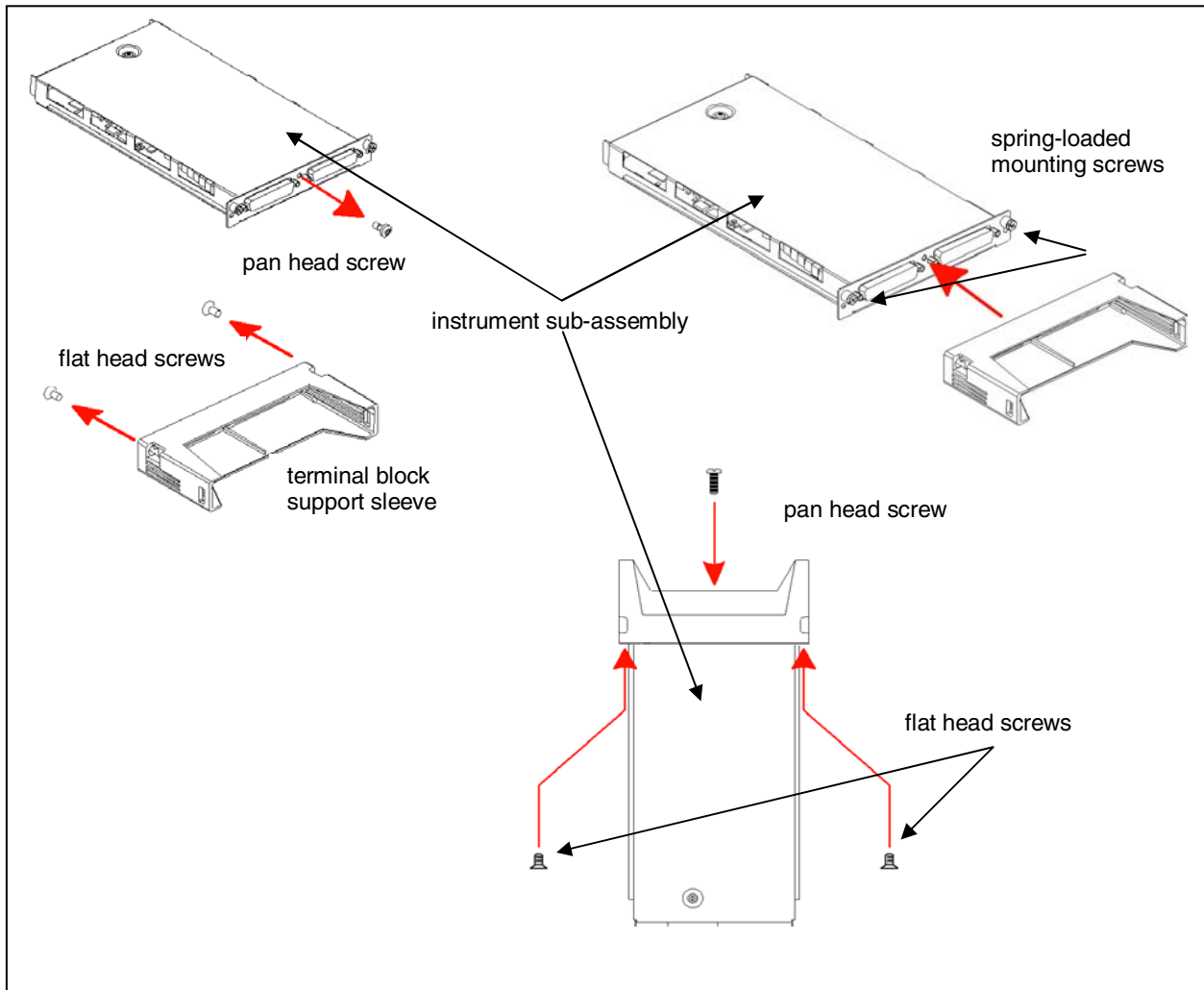

Figure 5. Connecting the Terminal Block Support Sleeve

Connect the Shelf to the Rack Frame

Once the instruments are installed and all power cords and cables are routed as intended, slide the shelf into the cabinet until the shelf handles meet the front-facing columns of the rack frame. Using two 10-32 pan head dress screws (item 2) per column, secure the shelf to the frame.

Support Contact Information

For questions regarding warranty, service or technical support for any Agilent product, contact Agilent Technologies at one of the following telephone numbers.

In the United States: (800) 829-4444

In Europe: 31 20 547 2111

In Japan: 0120-421-345

Or use our Web link for information on contacting Agilent in your country or specific location:

www.agilent.com/find/assist

Or contact your Agilent Technologies Representative.

© Agilent Technologies, Inc. 2006
Printed in Malaysia E0506
Edition 1 May 2006



Y1160-90030