

PNA Family Microwave Network Analyzers (N522x/3x/4xB)

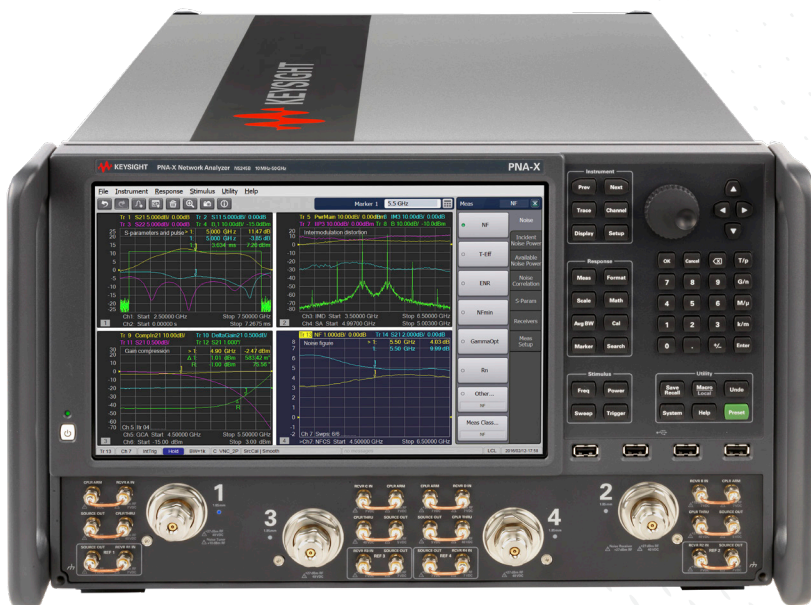
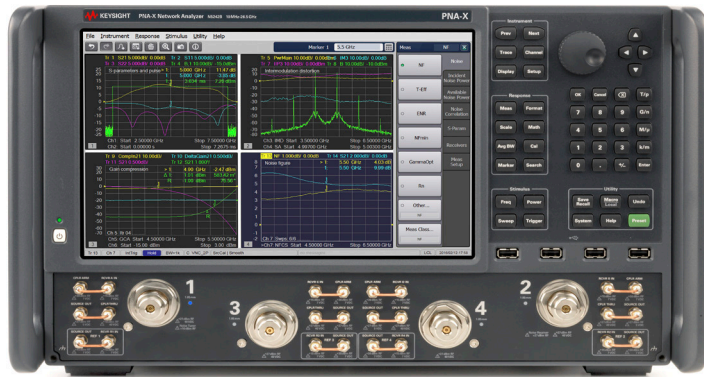

Table of Contents

PNA Family Network Analyzer Configurations.....	5
Test set and power configuration options.....	5
Hardware options.....	6
Application software.....	7
Accessories, calibration options.....	10
PNA-X Series Test Set and Power Configuration Options.....	11
PNA Series Test Set and Power Configuration Options.....	16
PNA-L Series Test Set and Power Configuration Options.....	20
PNA Family Applications and Options.....	21
Measurement application software.....	21
Noise figure options and applications.....	26
PNA-X block diagrams with noise figure option.....	27
Noise figure measurement summary.....	28
Pulse, antenna, mm-wave applications and options.....	30
Nonlinear vector network analysis.....	30
Keysight Software Licensing Options Provide Flexibility and Support.....	31
Choose your term. Choose your type. Keep control of your budget.....	31
KeysightCare Software Support Subscription provides peace of mind amid evolving technologies.....	31
Keysight Software Ordering Information.....	32
Applications.....	33
Material measurements.....	33
Signal integrity measurements.....	33
Multiport measurements.....	33
Test set options.....	34
Interface kits.....	34
Millimeter-wave measurements.....	34
Measurement Accessories.....	35
Cables and adapter sets.....	35
Calibration kits.....	35
For devices with 1.0 mm connectors.....	36
For devices with 1.85 mm connectors.....	36
For devices with 2.4 mm connectors.....	37
For devices with K connectors (2.92 mm).....	38
For devices with 3.5 mm or SMA connectors.....	40
For devices with Type-N connectors.....	42
For devices with 7 mm connectors.....	43
For devices with waveguide.....	43
Verification kits.....	44
Accessories.....	44
Spare drive.....	45
Probe.....	45
Power meters and sensors.....	46
Amplifiers.....	46
Couplers.....	46
Equipment rack accessories.....	46
Monitors.....	46
Interface cables.....	46
Active Device Characterization/Test Solution Bundle Models.....	47
PNA Family Network Analyzer Upgrade Kits.....	52
Frequency, test ports, test set and power configurations.....	52
Upgrade paths.....	54

This configuration guide describes standard configurations, options, accessories, upgrade kits and compatible peripherals for the PNA Family microwave network analyzers. This guide should be used with the Keysight Technologies, Inc. PNA Family data sheets for a complete description of these analyzers.



PNA-X Series

- N5249B 900 Hz/10 MHz to 8.5 GHz
- N5241B 900 Hz/10 MHz to 13.5 GHz
- N5242B 900 Hz/10 MHz to 26.5 GHz
- N5244B 900 Hz/10 MHz to 43.5 GHz
- N5245B 900 Hz/10 MHz to 50 GHz
- N5247B 900 Hz/10 MHz to 67 GHz (70 GHz)

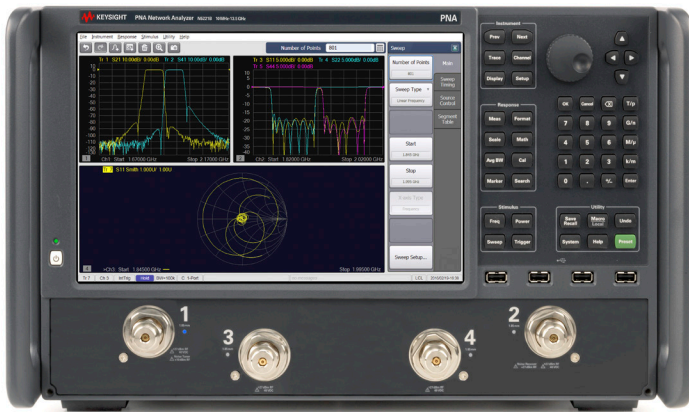

PNA Series

- N5221B 900 Hz/10 MHz to 13.5 GHz
- N5222B 900 Hz/10 MHz to 26.5 GHz
- N5224B 900 Hz/10 MHz to 43.5 GHz
- N5225B 900 Hz/10 MHz to 50 GHz
- N5227B 900 Hz/10 MHz to 67 GHz (70 GHz)



PNA-L Series

- N5239B 300 kHz to 8.5 GHz
- N5231B 300 kHz to 13.5 GHz
- N5232B 300 kHz to 20 GHz
- N5234B 10 MHz to 43.5 GHz
- N5235B 10 MHz to 50 GHz

Keysight Offers the Following Options for All PNA Family Network Analyzers

Certification options

Commercial calibration certification with test data (Option UK6)

Complete set of measurements which tests unit to manufacturer's published specifications. Includes calibration label, calibration certificate, and data report. Conforms to ISO 9001.

ISO 17025 compliant calibration (Option 1A7)

Complete set of measurements which tests unit to manufacturer's published specifications. Includes calibration label, ISO 17025 calibration certificate, and data report, measurement uncertainties and guardbands on all customer specifications. Conforms to ISO 17025 and ISO 9001.

ANSI Z540 compliant calibration (Option A6J)

Complete set of measurements which tests unit to manufacturer's published specifications. Includes pre- and post-adjustment data with measurement uncertainty information compliant to the ANSI/NCSL Z540 standard.

Documentation

The PNA Series instruments are equipped with an Online Help system available within the instrument in English only. All PNA documentation is available on the web:

www.keysight.com/find/pna

Calibration software licenses

Built-in performance test software for standard compliant cal (S93898B)

Adds built-in performance testing and calibration software for self-maintainers. Requires additional equipment. See the analyzer's Service Guide for more information on equipment required.

PNA Family Network Analyzer Configurations

PNA-X Series	PNA Series	PNA-L Series	Test port connector
N5249B 900 Hz/10 MHz to 8.5 GHz		N5239B 300 kHz to 8.5 GHz	3.5 mm (male)
N5241B 900 Hz/10 MHz to 13.5 GHz	N5221B 900 Hz/10 MHz to 13.5 GHz	N5231B 300 kHz to 13.5 GHz	3.5 mm (male)
N5242B 900 Hz/10 MHz to 26.5 GHz	N5222B 900 Hz/10 MHz to 26.5 GHz	N5232B 300 kHz to 20 GHz	3.5 mm (male)
N5244B 900 Hz/10 MHz to 43.5 GHz	N5224B 900 Hz/10 MHz to 43.5 GHz	N5234B 10 MHz to 43.5 GHz	2.4 mm (male)
N5245B 900 Hz/10 MHz to 50 GHz	N5225B 900 Hz/10 MHz to 50 GHz	N5235B 10 MHz to 50 GHz	2.4 mm (male)
N5247B 900 Hz/10 MHz to 67 GHz (70 GHz)	N5227B 900 Hz/10 MHz to 67 GHz (70 GHz)		1.85 mm (male)

Test set and power configuration options

Choose one test set and power configuration option. Option 2xx indicates two test ports. Option 4xx indicates four test ports. To add options to a product, order the corresponding item number (N52xxB-xxx).

Description	Configurable test set	Source attenuators	Receiver attenuators	Bias-tees	Internal second source	Internal combiner	Mechanical switches	Low-frequency extension (down to 900 Hz)	Additional information
PNA-X Series									
Option 201	•								
Option 205	•			•				•	Only available on N5241B/42B
Option 217	•	•	•						Not available on N5247B
Option 219	•	•	•	•					
Option 222 ¹	•	•	•		•	•	•		Not available on N5247B
Option 224 ¹	•	•	•	•	•	•	•		
Option 401 ¹	•				•				
Option 417 ¹	•	•	•		•				Not available on N5247B
Option 419 ¹	•	•	•	•	•				
Option 422 ¹	•	•	•		•	•	•		Not available on N5247B
Option 423 ¹	•	•	•	•	•	•	•		
Option 425 ¹	•	•	•	•	•	•	•	•	
PNA Series									
Option 200									
Option 201	•								
Option 205	•			•				•	
Option 210									2-port metrology option
Option 217	•	•	•						Not available on N5227B
Option 219	•	•	•	•					
Option 220	•	•	•	•				•	
Option 400 ¹					•				
Option 401 ¹	•				•				
Option 405 ¹	•				•			•	
Option 410 ¹					•				4-port metrology option
Option 417 ¹	•	•	•		•				Not available on N5227B
Option 419 ¹	•	•	•	•	•				
Option 420 ¹	•	•	•	•	•			•	
PNA-L Series									
Option 200									
Option 216	•	•							
Option 400									Available on only N5231/32B
Option 416 ²	•	•							Available on only N5231/32B

- To independently control the frequency of the second internal source, one of the following software applications is required: S93080/029/070x/082/083/084/086/087/089/090x/093/094B, or S94510/511B.
- Adds one source attenuator to be shared with all test ports.

PNA Family Network Analyzer Configurations (Continued)

PNA-X Series	PNA Series	PNA-L Series	Test port connector
N5249B 900 Hz/10 MHz to 8.5 GHz		N5239B 300 kHz to 8.5 GHz	3.5 mm (male)
N5241B 900 Hz/10 MHz to 13.5 GHz	N5221B 900 Hz/10 MHz to 13.5 GHz	N5231B 300 kHz to 13.5 GHz	3.5 mm (male)
N5242B 900 Hz/10 MHz to 26.5 GHz	N5222B 900 Hz/10 MHz to 26.5 GHz	N5232B 300 kHz to 20 GHz	3.5 mm (male)
N5244B 900 Hz/10 MHz to 43.5 GHz	N5224B 900 Hz/10 MHz to 43.5 GHz	N5234B 10 MHz to 43.5 GHz	2.4 mm (male)
N5245B 900 Hz/10 MHz to 50 GHz	N5225B 900 Hz/10 MHz to 50 GHz	N5235B 10 MHz to 50 GHz	2.4 mm (male)
N5247B 900 Hz/10 MHz to 67 GHz (70 GHz)	N5227B 900 Hz/10 MHz to 67 GHz (70 GHz)		1.85 mm (male)

Hardware options

Description	For PNA-X Series	For PNA Series	For PNA-L Series	Additional information
Add IF inputs	N524xB-020	N522xB-020	N/A	Used for antenna measurements and mm-wave extenders
Add pulse modulator to first source	N524xB-021	N522xB-021	N/A	
Add pulse modulator to second source	N524xB-022	N522xB-022	N/A	Requires one of Option 222, 224, 4xx
Add low-noise receiver	N524xB-029	N/A	N/A	S93029B application software is needed to control the noise receiver for noise figure and noise power measurements. For N5241/42/49B, requires one of options 21x, 22x, 41x, or 42x. For N5244/45/47B, requires one of options 22x or 42x. On N5247B, noise receiver works up to 50 GHz only.
Enhanced low phase noise	N524xB-UNY	N522xB-UNY	N/A	Export-controlled
Add third source	N524xB-XSB	N/A	N/A	Available only with option 422 or 423

PNA Family Network Analyzer Configurations (Continued)

PNA-X Series	PNA Series	PNA-L Series	Test port connector
N5249B 900 Hz/10 MHz to 8.5 GHz		N5239B 300 kHz to 8.5 GHz	3.5 mm (male)
N5241B 900 Hz/10 MHz to 13.5 GHz	N5221B 900 Hz/10 MHz to 13.5 GHz	N5231B 300 kHz to 13.5 GHz	3.5 mm (male)
N5242B 900 Hz/10 MHz to 26.5 GHz	N5222B 900 Hz/10 MHz to 26.5 GHz	N5232B 300 kHz to 20 GHz	3.5 mm (male)
N5244B 900 Hz/10 MHz to 43.5 GHz	N5224B 900 Hz/10 MHz to 43.5 GHz	N5234B 10 MHz to 43.5 GHz	2.4 mm (male)
N5245B 900 Hz/10 MHz to 50 GHz	N5225B 900 Hz/10 MHz to 50 GHz	N5235B 10 MHz to 50 GHz	2.4 mm (male)
N5247B 900 Hz/10 MHz to 67 GHz (70 GHz)	N5227B 900 Hz/10 MHz to 67 GHz (70 GHz)		1.85 mm (male)

Application software ¹

Description	For PNA-X Series	For PNA Series	For PNA-L Series	Additional Information
Automatic fixture removal	S93007B	S93007B	S93007B	
Time domain analysis	S93010B	S93010B	S93010B	
Enhanced time domain analysis with TDR	S93011B	S93011B	S93011B	Includes all capability of S93010B Does not work with Low-frequency extension (LFE)
Real-time S-parameter and power measurement uncertainty	S93015B	S93015B	S93015B ³	Displays the measurement uncertainty dynamically (real-time) on the measurement trace
Basic pulsed-RF measurements	S93025B	S93025B	N/A	Includes control of internal pulse generators and provides pulse widths to 200 ns using wideband detection
Advanced pulsed-RF measurements	S93026B	S93026B	N/A	Includes all capability of S93025B, and provides pulse widths to 100 ns using wideband detection, and 20 ns using narrowband detection
Add mechanical noise tuner control for noise figure/parameter measurements	S93027B	N/A	N/A	Provides ability to control Maury Microwave's LXI impedance tuners. Requires application software S93029B.
Noise figure measurements with vector correction ²	S93029B	S93029B	N/A	Standard receivers are used if hardware option N524xB-029 is not present
Phase noise measurement up to 70 GHz	S930317B	S930317B	N/A	Direct Digital Synthesizer (DDS) source is required. (S/N prefix 6021 or after, or upgraded unit with N52xxBU-2S7 or 4S7)
Phase noise measurement up to 125 GHz	S930321B	S930321B	N/A	This is for N5290A/91A or N5292A with N5293AX/95AX frequency extenders configuration. Direct Digital Synthesizer (DDS) source is required on PNA/PNA-X (S/N prefix 6021 or after, or upgraded unit with N52xxBU-2S7 or 4S7)
Modulation distortion up to 8.5 GHz	S930700B	N/A	N/A	Requires N524xB-22x/42x (Option 42x is recommended) Requires a supported vector signal generator ⁴
Modulation distortion up to 13.5 GHz	S930701B	N/A	N/A	Requires N524xB-22x/42x (Option 42x is recommended) Requires a supported vector signal generator ⁴
Modulation distortion up to 26.5 GHz	S930702B	N/A	N/A	Requires N524xB-22x/42x (Option 42x is recommended) Requires a supported vector signal generator ⁴
Modulation distortion up to 43.5 GHz	S930704B	N/A	N/A	Requires N524xB-22x/42x (Option 42x is recommended) Requires a supported vector signal generator ⁴
Modulation distortion up to 50 GHz	S930705B	N/A	N/A	Requires N524xB-22x/42x (Option 42x is recommended) Requires a supported vector signal generator ⁴
Modulation distortion up to 70 GHz	S930707B	N/A	N/A	Requires N524xB-22x/42x (Option 42x is recommended) Requires a supported vector signal generator ⁴
Frequency-offset measurements	S93080B	S93080B	S93080B	Provides ability to independently set the frequency of internal sources and receivers, and to configure external sources. This functionality is included with S93029/ 070x/082/083/084/086/087/089/090x /093/094B or S94510/511B/A.

- The S9xxxxB software has six license types, please refer to "Keysight Software Licensing Options Provide Flexibility and Support" on page 31 for more details.
- For N522xB and N5241/42/49B, vector-noise-corrected measurements require an ECal for use as an impedance tuner. For N5244/45/47B with Option 029, an internal tuner is included. Noise calibration requires a power meter when using a standard receiver. When using the low-noise receiver (Option 029), either a power meter or a 346-series noise source is required (Keysight 346C or 346C-K01 recommended). A power meter is required for measuring mixers and converters.
- S93015B is not available on N5231B, N5232B and N5239B.
- See the S93070xB description on page 22 for the supported signal generators.

PNA Family Network Analyzer Configurations (Continued)

PNA-X Series	PNA Series	PNA-L Series	Test port connector
N5249B 900 Hz/10 MHz to 8.5 GHz		N5239B 300 kHz to 8.5 GHz	3.5 mm (male)
N5241B 900 Hz/10 MHz to 13.5 GHz	N5221B 900 Hz/10 MHz to 13.5 GHz	N5231B 300 kHz to 13.5 GHz	3.5 mm (male)
N5242B 900 Hz/10 MHz to 26.5 GHz	N5222B 900 Hz/10 MHz to 26.5 GHz	N5232B 300 kHz to 20 GHz	3.5 mm (male)
N5244B 900 Hz/10 MHz to 43.5 GHz	N5224B 900 Hz/10 MHz to 43.5 GHz	N5234B 10 MHz to 43.5 GHz	2.4 mm (male)
N5245B 900 Hz/10 MHz to 50 GHz	N5225B 900 Hz/10 MHz to 50 GHz	N5235B 10 MHz to 50 GHz	2.4 mm (male)
N5247B 900 Hz/10 MHz to 67 GHz (70 GHz)	N5227B 900 Hz/10 MHz to 67 GHz (70 GHz)		1.85 mm (male)

Application software ¹ (Continued)

Description	For PNA-X Series	For PNA Series	For PNA-L Series	Additional Information
Scalar mixer/converter measurements	S93082B	S93082B	S93082B	Provides SMC measurement class. S93082B is a subset of S93083B
Vector and scalar mixer/converter measurements ²	S93083B	S93083B	N/A	Provides SMC+Phase and VMC measurement classes
Embedded-LO capability	S93084B	S93084B	N/A	Works with S93029/082/083/086/087B
Gain-compression measurements	S93086B	S93086B	N/A	
Intermodulation distortion measurements ³	S93087B	S93087B	N/A	Not available with PNA test set options 200, 210, 400, and 410
Source phase control	S93088B	S93088B	N/A	
Differential and I/Q device measurements	S93089B	S93089B	N/A	Requires a 4-port test set option (4xx)

1. The S9xxxxB software has six license types, please refer to "Keysight Software Licensing Options Provide Flexibility and Support" on page 31 for more details.
2. A configurable test set is required for VMC measurements to connect a reference mixer, or for SMC+Phase measurements using the comb-generator-based calibration. When ordered with PNA test set Options 200, 210, 400, or 410 (no front-panel jumpers), phase and delay measurements can only be done using SMC+Phase with a calibration mixer.
3. S93087B can be used without PNA-X Options 22x or 42x, but external equipment such as a signal generator and a combiner may be required. Refer to page 23 for more details.

PNA Family Network Analyzer Configurations (Continued)

PNA-X Series	PNA Series	PNA-L Series	Test Port Connector
N5249B 900 Hz/10 MHz to 8.5 GHz		N5239B 300 kHz to 8.5 GHz	3.5 mm (male)
N5241B 900 Hz/10 MHz to 13.5 GHz	N5221B 900 Hz/10 MHz to 13.5 GHz	N5231B 300 kHz to 13.5 GHz	3.5 mm (male)
N5242B 900 Hz/10 MHz to 26.5 GHz	N5222B 900 Hz/10 MHz to 26.5 GHz	N5232B 300 kHz to 20 GHz	3.5 mm (male)
N5244B 900 Hz/10 MHz to 43.5 GHz	N5224B 900 Hz/10 MHz to 43.5 GHz	N5234B 10 MHz to 43.5 GHz	2.4 mm (male)
N5245B 900 Hz/10 MHz to 50 GHz	N5225B 900 Hz/10 MHz to 50 GHz	N5235B 10 MHz to 50 GHz	2.4 mm (male)
N5247B 900 Hz/10 MHz to 67 GHz (70 GHz)	N5227B 900 Hz/10 MHz to 67 GHz (70 GHz)		1.85 mm (male)

Application software ¹ (Continued)

Description	For PNA-X Series	For PNA Series	For PNA-L Series	Additional information
Spectrum analysis, up to 8.5 GHz ²	S930900B	S930900B	S930900B	
Spectrum analysis, up to 13.5 GHz ²	S930901B	S930901B	S930901B	
Spectrum analysis, up to 26.5 GHz ²	S930902B	S930902B	S930902B	
Spectrum analysis, up to 43.5 GHz ²	S930904B	S930904B	S930904B	
Spectrum analysis, up to 50 GHz ²	S930905B	S930905B	S930905B	
Spectrum analysis, up to 70 GHz ²	S930907B	S930907B	N/A	
Spectrum analysis, up to 90 GHz ²	S930909B	S930909B	N/A	
Spectrum analysis, up to 120 GHz	S93093B	S93093B	N/A	
Spectrum analysis, beyond 120 GHz	S93094B	S93094B	N/A	
Active hot parameters	S93110B	N/A	N/A	Export-controlled. Requires a 4-port test set option (4xx) Low-frequency extension (LFE) is disabled with Option 425
Active hot parameters	S93111B	N/A	N/A	Function-restricted version for N5247B with maximum operation to 50 GHz Requires a 4-port test set Option (4xx) Low-frequency extension (LFE) is disabled with Option 425
Fast CW measurements	S93118B	S93118B	N/A	
True-mode stimulus	S93460B	S93460B	N/A	Requires a 4-port test set option (4xx)
N-port measurements ³	S93551B ⁴	S93551B	S93551B	Not available with PNA test set options 200, 210, 400, and 410
Device measurement expert (DMX)	S94601B	S94601B	S94601B	
Limit assistant	S94602B	S94602B	S94602B	
Nonlinear vector network analysis ⁵				
Nonlinear component characterization	S94510B ⁶	N/A	N/A	Export-controlled. Requires test set option 41x or 42x
Nonlinear component characterization	S94511B ⁶	N/A	N/A	Function-restricted version. Requires test set option 41x or 42x
Nonlinear X-parameters ^{8,9}	S94514B ⁷	N/A	N/A	Requires test set option 42x and application software S94510B or S94511B
Nonlinear pulse-envelope domain	S94518B	N/A	N/A	Requires hardware option 021 and application software S94510B/A or S94511B, and S93025B or S93026B
Arbitrary load-impedance X-parameters ^{8,9}	S94520B	N/A	N/A	Requires application software S94514B and an additional load-control application
Arbitrary load-control X-parameters ^{8,9,12}	S94521B	N/A	N/A	Requires application software S94520B
Arbitrary load-control device characterization ^{10,11,12}	S94522B	N/A	N/A	Requires application software S94510B or S94511B

- The S9xxxB software has six license types, please refer to "Keysight Software Licensing Options Provide Flexibility and Support" on page 31 for more details.
- For use with PNA or PNA-X models, a test set with internal receiver attenuators is recommended to avoid receiver compression when measuring large input signals. For use with PNA-L models, test set option 216 or 416 is recommended so that external attenuators can be connected via the front-panel jumpers to avoid receiver compression as needed.
- When ordering a test set, select an appropriate interface kit. Refer to Multipoint Measurements section on page 34 for more details.
- When N524xB is configured as a multipoint analyzer using S93551B and a multipoint test set, the combiner feature of Option 22x or 42x is temporarily disabled. When configured as a standalone analyzer, the combiner feature is enabled.
- A fully configured NVNA system requires two comb generators with power supplies, Keysight calibration kits (mechanical or ECal), and a power meter and sensor or USB power sensor.
- Pulse capability requires option 021 and S93025B or S93026B.
- Pulse capability requires option 021, 022 and S93025B or S93026B.
- Requires EXG, MXG, or PSG signal generator for X-parameter extraction (the PNA-X's 10 MHz reference output can be used for 10 MHz tone-spacing applications).
- X-parameters is a trademark and registered trademark of Keysight Technologies in the U.S., Europe, Japan, and elsewhere. The X-parameters format and underlying equations are open and documented. For more information, visit www.keysight.com/find/eesof-x-parameters-info.
- Currently CW stimulus only.
- Use of this application will generally require external sources, couplers attenuators, wafer probe station and more to complete system configuration. Please work with your local Keysight application engineer for details.
- Requires Win 7 OS or above.

PNA Family Network Analyzer Configurations (Continued)

PNA-X Series	PNA Series	PNA-L Series	Test port connector
N5249B 900 Hz/10 MHz to 8.5 GHz		N5239B 300 kHz to 8.5 GHz	3.5 mm (male)
N5241B 900 Hz/10 MHz to 13.5 GHz	N5221B 900 Hz/10 MHz to 13.5 GHz	N5231B 300 kHz to 13.5 GHz	3.5 mm (male)
N5242B 900 Hz/10 MHz to 26.5 GHz	N5222B 900 Hz/10 MHz to 26.5 GHz	N5232B 300 kHz to 20 GHz	3.5 mm (male)
N5244B 900 Hz/10 MHz to 43.5 GHz	N5224B 900 Hz/10 MHz to 43.5 GHz	N5234B 10 MHz to 43.5 GHz	2.4 mm (male)
N5245B 900 Hz/10 MHz to 50 GHz	N5225B 900 Hz/10 MHz to 50 GHz	N5235B 10 MHz to 50 GHz	2.4 mm (male)
N5247B 900 Hz/10 MHz to 67 GHz (70 GHz)	N5227B 900 Hz/10 MHz to 67 GHz (70 GHz)		1.85 mm (male)

Accessories, calibration options

Description	For PNA-X Series	For PNA Series	For PNA-L Series	Additional information
Accessories				
Rack mount kit for use without handles	N524xB-1CM	N522xB-1CM	N523xB-1CM	
Rack mount kit for use with handles	N524xB-1CP	N522xB-1CP	N523xB-1CP	
Pulse I/O adapter	N1966A	N1966A	N/A	
Comb generator ¹	U9391C/F/G	N/A	N/A	
Calibration software				
Built-in performance test software for standard compliant calibration ²	S93898B	S93898B	S93898B	
Calibration documentation				
ISO 17025 compliant calibration	N524xB-1A7	N522xB-1A7	N523xB-1A7	
Commercial calibration certificate with test data	N524xB-UK6	N522xB-UK6	N523xB-UK6	
ANSI Z540 compliant calibration	N524xB-A6J	N522xB-A6J	N523xB-A6J	

1. A fully configured NVNA system requires two comb generators with power supplies, Keysight calibration kits (mechanical or ECal), and a power meter and sensor or USB power sensor.
2. Additional hardware required. Please refer to the analyzer's service guide for required service-test equipment.

Application software compatibility with LFE (Low Frequency Extension to 900 Hz) feature

Application software	Description	LFE Supported
S93007B	Automatic fixture removal	Yes
S93010B	Time domain analysis	Yes
S93011B	Enhanced time domain analysis	No
S93015B	Real-time S-parameter and power measurement uncertainty	Yes
S93025B	Basic pulsed-RF measurements	Yes
S93026B	Advanced pulsed-RF measurements	No
S93027B	Add mechanical noise tuner control for noise figure/parameter measurements	No
S93029B	Noise figure measurements with vector correction	No
S9303xxB	phase noise measurement	No
S93070xB	Modulation distortion	No
S93080B	Frequency-offset measurements	Yes
S93082B	Scalar mixer/converter measurements	Yes, but magnitude-only
S93083B	Vector mixer/converter measurements	Yes, but Magnitude-only in SMC+Phase.
S93084B	Embedded-LO capability	No
S93086B	Gain-compression measurements	Yes
S93087A	Intermodulation distortion measurements	No
S93088B	Source phase control	Yes
S93089B	Differential and I/Q device measurements	No
S93090xB	Spectrum Analysis	No
S9311xB	Active hot parameters	No
S93118B	Fast CW measurements	Yes
S93551B	N-port measurements	Depends on the test set.
S93460B	True-mode stimulus	Yes
S94601B	Device measurement expert (DMX)	Yes
S94602B	Limit assistant	Yes
S945xxB	Nonlinear vector network analysis	No

PNA-X Series Test Set and Power Configuration Options ¹

The PNA-X is an integrated vector network analyzer featuring a built-in S-parameter test set, one or two synthesized sources used for device stimulus, a solid-state drive, USB interfaces, and a 12.1" LCD touch screen display. The N5241B, N5242B, and N5249B have 50 ohm, ruggedized 3.5 mm (m) test ports. The N5244B and the N5245B have 50 ohm, ruggedized 2.4 mm (m) test ports. The N5247B has 50 ohm, ruggedized 1.85 mm (m) test ports. Included with each instrument is a mouse, keyboard (U.S. style), and one day of on-site productivity assistance (PS-S20-PNA).

A test set and power configuration option is mandatory, choose one of the following:

2-ports, single source, with configurable test set (Option 201)

The standard 2-port test set comes with six front-panel access loops. The loops provide access to the signal path between (a) the source output and the reference receiver, (b) the source output and directional coupler thru arm and (c) the coupled arm of the directional coupler and the port receiver. The standard test set also includes a solid-state internal RF bypass switch in the R1 reference-receiver path.

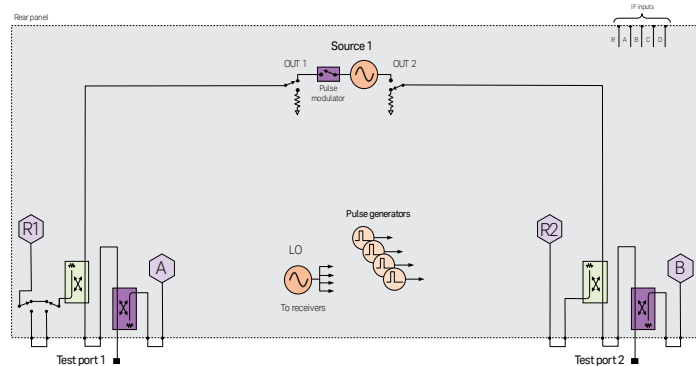

2-ports, single source, with configurable test set and low frequency extension (Option 205)

Along with 2-port single source with the access loops with Option 201, Option 205 adds bias tees and additional hardware to extend the start frequency of the PNA-X down to 900 Hz. The extended start frequency is available only for the following measurement classes: standard, gain compression (amplifier and converters), and for magnitude-only measurements using SMC (scalar mixer/converter) or SMC+Phase. In the standard channel, pulsed RF, true-mode stimulus, and source phase control are not supported for measurements below 10 MHz. The block diagram below shows how the low-frequency hardware is configured for one test port; the other test ports are configured similarly. For test port 1, the combiner and noise tuner (not shown) are only available for use down to 10 MHz, and for test port 2, the low-noise receiver (not shown) is only available for use down to 10 MHz.

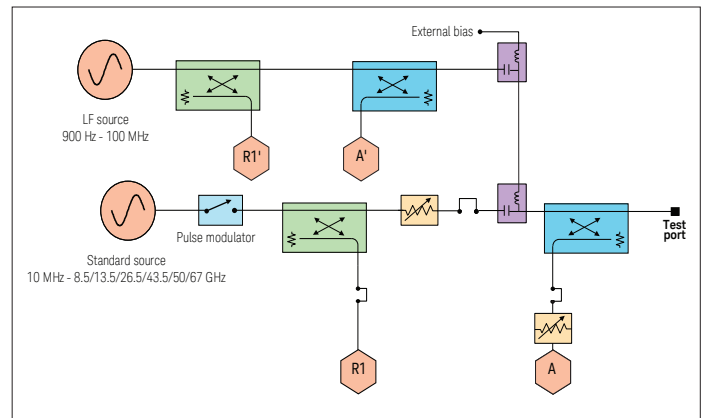

1. The block diagrams shown above include hardware that must be ordered as separate options, such as pulse modulators (Options 021 and 022), and IF access (Option 020), or is controlled by application software, as is the case for the pulse generators. In addition, the combiner type and attenuator values vary by model number. Refer to the product data sheet for the correct block diagram for a specific model.

PNA-X Series Test Set and Power Configuration Options ¹ (Continued)

2-ports, single source, with extended power range (Option 217)

This configuration comes with front-panel access loops, and source and receiver attenuators at each port. The source attenuators are settable in 5 dB steps up to 65 dB in N5241/42/49B, and in 10 dB steps up to 60 dB in N5244/45B. The receiver attenuators are settable in 5 dB steps up to 35 dB. The maximum power rating on the test port couplers is +43 dBm (additional attenuators or isolators are typically required to protect other components inside the instrument). Option 217 is not available on the N5247B.

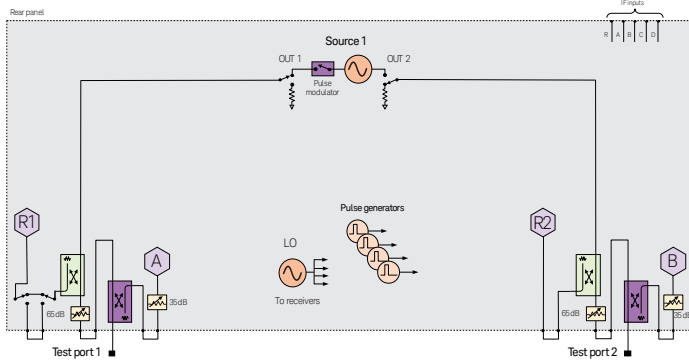

2-ports, single source, with extended power range and bias-tees (Option 219)

This configuration comes with front-panel access loops, and bias tees and source and receiver attenuators at each port. The source attenuators are settable in 5 dB steps up to 65 dB in N5241/42/49B, in 10 dB steps up to 60 dB in N5244/45B, and in 10 dB steps up to 50 dB in N5247B. The receiver attenuators are settable in 5 dB steps up to 35 dB in N5241/42/44/45/49B, and 10 dB steps up to 50 dB in N5247B. The bias tees are connected directly to the test port couplers, which limits the maximum power rating on the pair to +30 dBm (additional attenuators or isolators are typically required to protect other components inside the instrument).

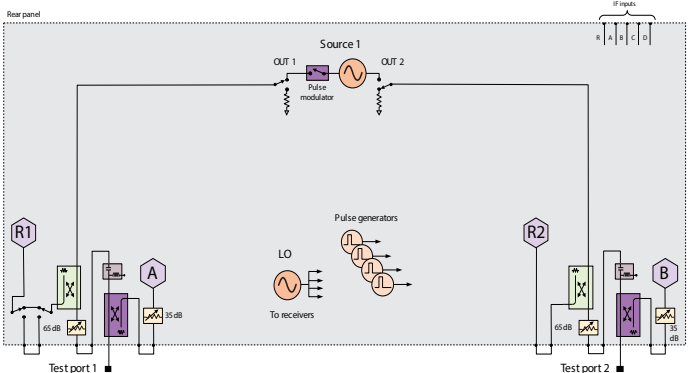

2-ports, dual sources, with extended power range, combiner, and mechanical switches (Option 222)

Along with the access loops and attenuators of Option 217, Option 222 includes an internal second source, a combiner, mechanical switches, and more access loops. The internal second source provides an additional signal (fixed or swept) for two-tone intermodulation testing of amplifiers, or for use as a local oscillator for testing mixers and frequency converters. The mechanical switches switch the combiner in and out as needed, as well as enabling the additional access loops for advanced configurations. The second source is available through two RF connectors on the front panel, from port 1 when combined with source 1, or via rear-panel access loops. The maximum power rating on the test port couplers is +43 dBm (additional attenuators or isolators are typically required to protect other components inside the instrument). Option 222 is not available on the N5247B. To independently control the frequency of the second internal source, one of the following software applications is required: S93080/029/070x/082/083/084/086/087/089/090x/093/094B.

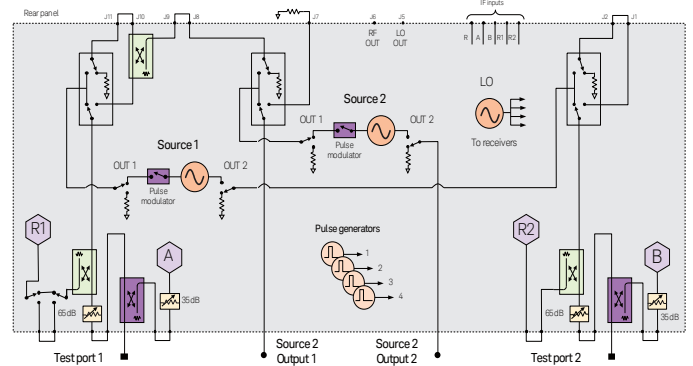

1. The block diagrams shown above include hardware that must be ordered as separate options, such as pulse modulators (Options 021 and 022), and IF access (Option 020), or is controlled by application software, as is the case for the pulse generators. In addition, the combiner type and attenuator values vary by model number. Refer to the product data sheet for the correct block diagram for a specific model.

PNA-X Series Test Set and Power Configuration Options ¹ (Continued)

2-ports, dual sources, with extended power range, bias tees, and mechanical switches (Option 224)

Along with the access loops, attenuators, and bias tees of Option 219, Option 224 includes an internal second source, a combiner, mechanical switches, and more access loops. The internal second source provides an additional signal (fixed or swept) for two-tone intermodulation testing of amplifiers, or for use as a local oscillator for testing mixers and frequency converters. The mechanical switches switch the combiner in and out as needed, as well as enabling the additional access loops for advanced configurations. The second source is available through two RF connectors on the front panel, from port 1 when combined with source 1, or via rear-panel (N5241/42/44/45/49B) or front-panel (N5247B) access loops. The bias tees are connected directly to the test port couplers, which limits the maximum power rating on the pair to +30 dBm (additional attenuators or isolators are typically required to protect other components inside the instrument). To independently control the frequency of the second internal source, one of the following software applications is required: S93080/029/070x/082/083/084/086/087/089/090x/093/094B.

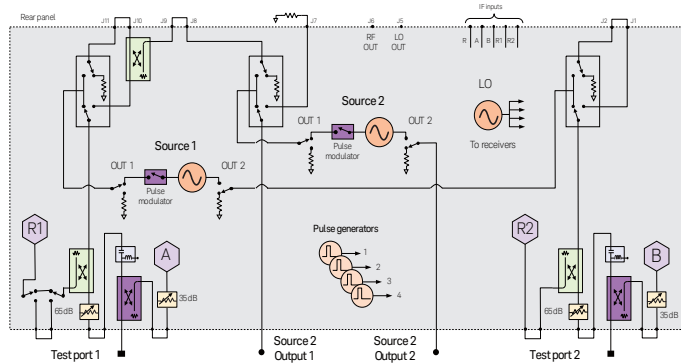

4-ports, dual sources, with configurable test set (Option 401)

The standard 4-port test set comes with 12 front-panel access loops and a built-in second source. The loops provide access to the signal path between (a) the source output and the reference receiver, (b) the source output and directional coupler thru arm and (c) the coupled arm of the directional coupler and the port receiver. The internal second source provides an additional signal (fixed or swept) for two-tone intermodulation testing of amplifiers, or for use as a local oscillator when testing mixers and frequency converters. Source 1 is accessible through test ports 1 and 2, and source 2 is accessible through test ports 3 and 4. The standard test set also includes a solid-state internal RF bypass switch in the R1 reference-receiver path.

To independently control the frequency of the second internal source, one of the following software applications is required: S93080/029/082/083/084/086/087/089/090x/093/094B.

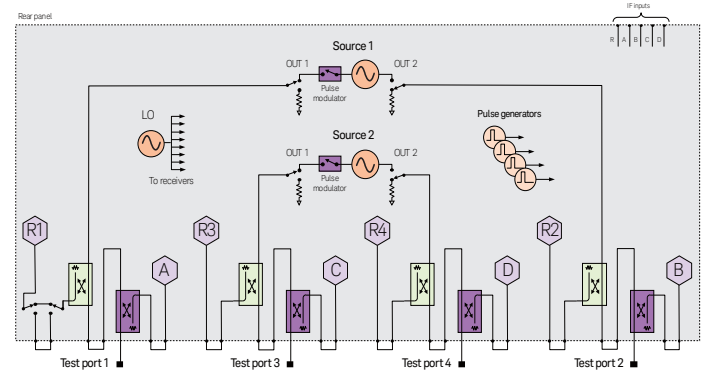

4-ports, dual sources, with extended power range (Option 417)

This configuration comes with two sources, front-panel access loops, and source and receiver attenuators at each port. The source attenuators are settable in 5 dB steps up to 65 dB in N5241/42/49B, and in 10 dB steps up to 60 dB in N5244/45B. The receiver attenuators are settable in 5 dB steps up to 35 dB. The maximum power rating on the test port couplers is +43 dBm (additional attenuators or isolators are typically required to protect other components inside the instrument). Option 417 is not available on the N5247B. To independently control the frequency of the second internal source, one of the following software applications is required: S93080/029/082/083/084/086/087/089/090x/093/094B, and S94510/511B/A.

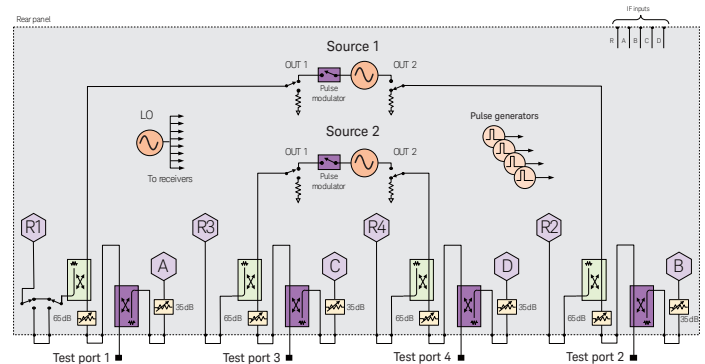

1. The block diagrams shown above include hardware that must be ordered as separate options, such as pulse modulators (Options 021 and 022), and IF access (Option 020), or is controlled by application software, as is the case for the pulse generators. In addition, the combiner type and attenuator values vary by model number. Refer to the product data sheet for the correct block diagram for a specific model.

PNA-X Series Test Set and Power Configuration Options ¹ (Continued)

4-ports, dual sources, with extended power range and bias-tees (Option 419)

This configuration comes with two sources, front-panel access loops, and bias tees and source and receiver attenuators at each port. The source attenuators are settable in 5 dB steps up to 65 dB in N5241/42/49B, in 10 dB steps up to 60 dB in N5244/45B, and in 10 dB steps up to 50 dB in N5247B. The receiver attenuators are settable in 5 dB steps up to 35 dB in N5241/42/44/45/49B, and 10 dB steps up to 50 dB in N5247B. The bias tees are connected directly to the test port couplers, which limits the maximum power rating on the pair to +30 dBm (additional attenuators or isolators are typically required to protect other components inside the instrument). To independently control the frequency of the second internal source, one of the following software applications is required: S93080/029/082/083/084/086/087/089/090x/093/094B or S94510/511B/A.

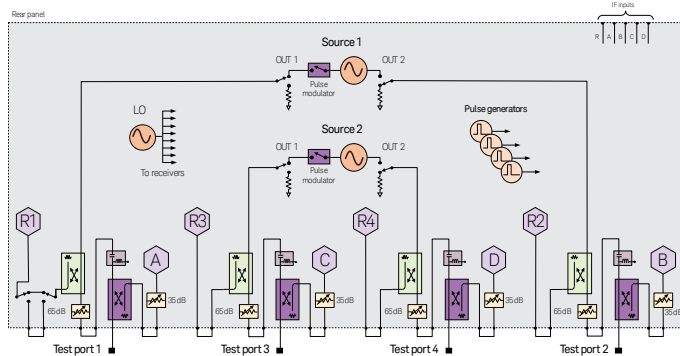

4-ports, dual sources, with extended power range, combiner, and mechanical switches (Option 422)

Along with two sources and the access loops and attenuators of Option 417, Option 422 includes a combiner, mechanical switches, and more access loops. The internal second source provides an additional signal (fixed or swept) for two-tone intermodulation testing of amplifiers, or for use as a local oscillator for testing mixers and frequency converters. The mechanical switches switch the combiner in and out as needed, as well as enabling the additional access loops for advanced configurations. The second source drives ports 3 and 4, and is also available from port 1 when combined with source 1, or via rear-panel access loops. The maximum power rating on the test port couplers is +43 dBm (additional attenuators or isolators are typically required to protect other components inside the instrument). Option 422 is not available on the N5247B. To independently control the frequency of the second internal source, one of the following software applications is required: S93080/029/070x/082/083/084/86/087/089/090x/093/094B or S94510/511B/A.

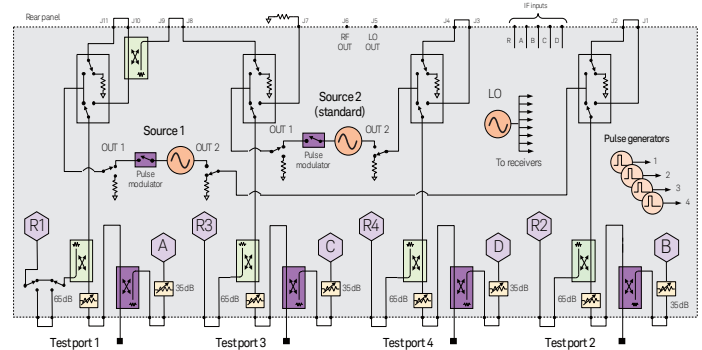

1. The block diagrams shown above include hardware that must be ordered as separate options, such as pulse modulators (Options 021 and 022), and IF access (Option 020), or is controlled by application software, as is the case for the pulse generators. In addition, the combiner type and attenuator values vary by model number. Refer to the product data sheet for the correct block diagram for a specific model.

PNA-X Series Test Set and Power Configuration Options (Continued)

4-ports, dual sources, with extended power range, bias tees, combiner, and mechanical switches (Option 423)

Along with two sources and the access loops, attenuators, and bias tees of Option 419, Option 423 includes a combiner, mechanical switches, and more access loops. The internal second source provides an additional signal (fixed or swept) for two-tone intermodulation testing of amplifiers, or for use as a local oscillator for testing mixers and frequency converters. The mechanical switches switch the combiner in and out as needed, as well as enabling the additional access loops for advanced configurations. The second source drives ports 3 and 4, and is also available from port 1 when combined with source 1, or via rear-panel (N5241/42/44/45/49B) or front-panel (N5247B) access loops. The bias tees are connected directly to the test port couplers, which limits the maximum power rating on the pair to +30 dBm (additional attenuators or isolators are typically required to protect other components inside the instrument). To independently control the frequency of the second internal source, one of the following software applications is required: S93080/029/070x/082/083/084/086/087/089/090x/093/094B or S94510/511B/A. The block diagram below shows how the low-frequency hardware is configured for one test port; the other test ports are configured similarly. For test port 1, the combiner and noise tuner (not shown) are only available for use down to 10 MHz, and for test port 2, the low-noise receiver (not shown) is only available for use down to 10 MHz.

To independently control the frequency of the second internal source, one of the following software applications is required: S93080/029/070x/082/083/084/086/087/089/090x/093/094B or S94510/511B/A. The block diagram below shows how the low-frequency hardware is configured for one test port; the other test ports are configured similarly. For test port 1, the combiner and noise tuner (not shown) are only available for use down to 10 MHz, and for test port 2, the low-noise receiver (not shown) is only available for use down to 10 MHz.

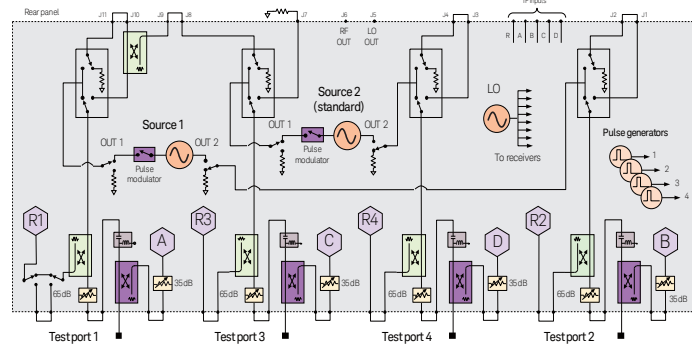
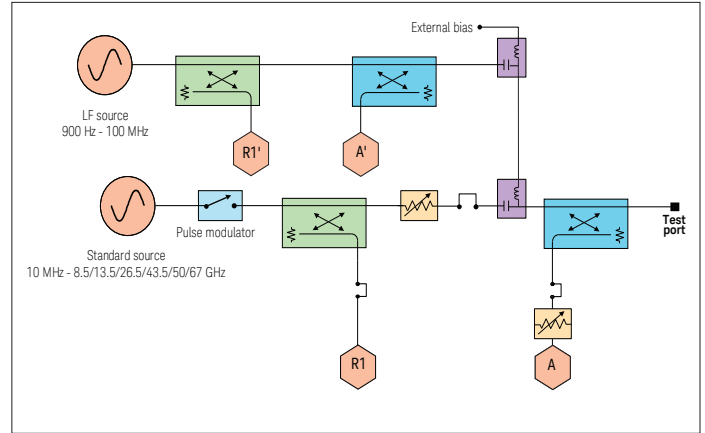

Optional 3rd source

Option XSB adds the 3rd source (Source 3) to 4-port PNA-X with option 422 or 423. The frequency of the 3rd source is up to 8.5 GHz for N5249B and 13.5 GHz for the other N524xBs. The source port is located on the rear panel. If you connect a jumper on the rear panel, it can also be re-routed to a test port on the front panel.

4-ports, dual sources, with extended power range, bias tees, combiner, mechanical switches, and low-frequency extension (Option 425)

Along with two sources and the access loops, attenuators, bias tees, combiner, and mechanical switches of Option 423, Option 425 adds additional hardware to extend the start frequency of the PNA-X down to 900 Hz. The extended start frequency is available only for the following measurement classes: standard, gain compression (amplifier and converters), and for magnitude-only measurements using SMC (scalar mixer/converter) or SMC+Phase. In the standard channel, pulsed RF, true-mode stimulus, and source phase control are not supported for measurements below 10 MHz.

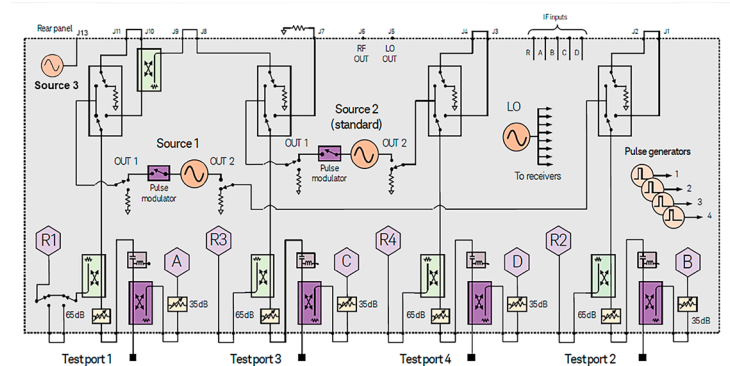

1. The block diagrams shown above include hardware that must be ordered as separate options, such as pulse modulators (Options 021 and 022), and IF access (Option 020), or is controlled by application software, as is the case for the pulse generators. In addition, the combiner type and attenuator values vary by model number. Refer to the product data sheet for the correct block diagram for a specific model.

PNA Series Test Set and Power Configuration Options ¹

The PNA is an integrated vector network analyzer featuring a built-in S-parameter test set, one or two synthesized sources used for device stimulus, a solid-state drive, USB interfaces, and a 12.1" LCD touch screen display. The N5221B and the N5222B have 50 ohm, ruggedized 3.5 mm (m) test ports. The N5224B and the N5225B have 50 ohm, ruggedized 2.4 mm (m) test ports. The N5227B has 50 ohm, ruggedized 1.85 mm (m) test ports. Included with each instrument is a mouse, keyboard (U.S. style), test port torque wrench, and one day of on-site productivity assistance (PS-S20-PNA).

A test set and power configuration option is mandatory. Choose one of the following:

2-ports, single source, base configuration (Option 200/210)

The 2-port with base configuration has no front-panel access loops.

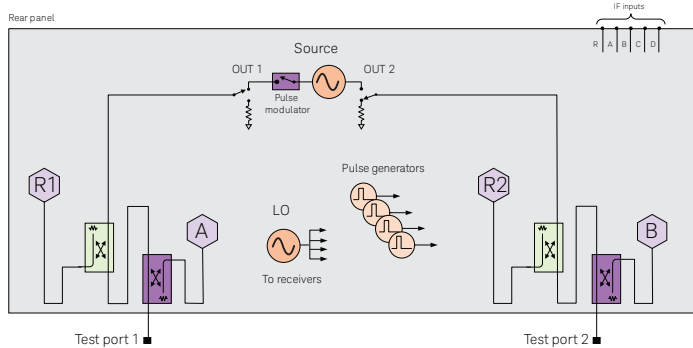

2-ports, single source, with configurable test set, bias tees, and low-frequency extension (Option 205)

Along with the front-panel loops and R1 reference-receiver switch of Option 201, Option 205 adds bias tees and additional hardware to extend the start frequency of the PNA down to 900 Hz. The extended start frequency is available only for the following measurement classes: standard, gain compression (amplifier and converters), and for magnitude-only measurements using SMC (scalar mixer/converter) or SMC+Phase. In the standard channel, pulsed RF, true-mode stimulus, and source phase control are not supported for measurements below 10 MHz. The block diagram below shows how the low-frequency hardware is configured for one test port; the other test ports are configured similarly.

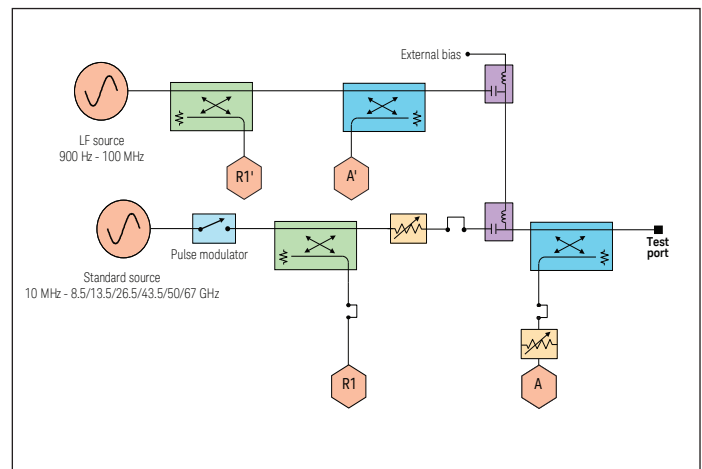

2-ports, single source, with configurable test set (Option 201)

The 2-port configurable test set comes with six front-panel access loops. The loops provide access to the signal path between (a) the source output and the reference receiver, (b) the source output and directional coupler thru arm and (c) the coupled arm of the directional coupler and the port receiver at all ports. Also included is a solid-state internal RF bypass switch in the R1 reference-receiver path.

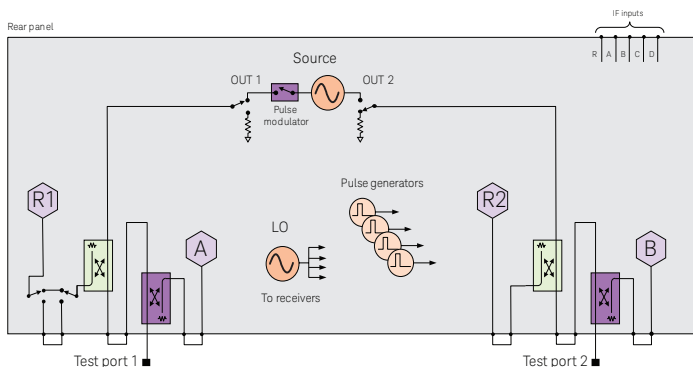

1. The block diagrams shown above include hardware that must be ordered as separate options, such as pulse modulators (Option 021), and IF access (Option 020), or is controlled by application software, as is the case for the pulse generators. In addition, the combiner type and attenuator values vary by model number. Refer to the product data sheet for the correct block diagram for a specific model.

PNA Series Test Set and Power Configuration Options ¹ (Continued)

2-ports, single source, with extended power range (Option 217)

This configuration comes with front-panel access loops, and source and receiver attenuators at each port. The source attenuators are settable in 5 dB steps up to 65 dB in N5221/22B, and in 10 dB steps up to 60 dB in N5224/25B. The receiver attenuators are settable in 5 dB steps up to 35 dB. The maximum power rating on the test port couplers is +43 dBm (additional attenuators or isolators are typically required to protect other components inside the instrument). Option 217 is not available on the N5227B.

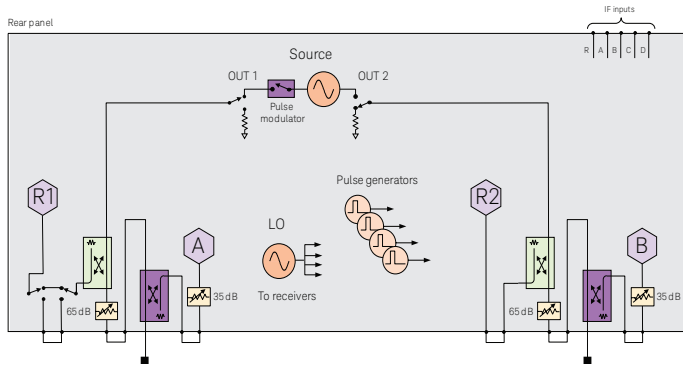

2-ports, single source, with extended power range and bias-tees (Option 219)

This configuration comes with front-panel access loops, and bias tees and source and receiver attenuators at each port. The source attenuators are settable in 5 dB steps up to 65 dB in N5221/22B, in 10 dB steps up to 60 dB in N5224/25B, and in 10 dB steps up to 50 dB in N5227B. The receiver attenuators are settable in 5 dB steps up to 35 dB in N5221/22/24/25B, and 10 dB steps up to 50 dB in N5227B. The bias tees are connected directly to the test port couplers, which limits the maximum power rating on the pair to +30 dBm (additional attenuators or isolators are typically required to protect other components inside the instrument).

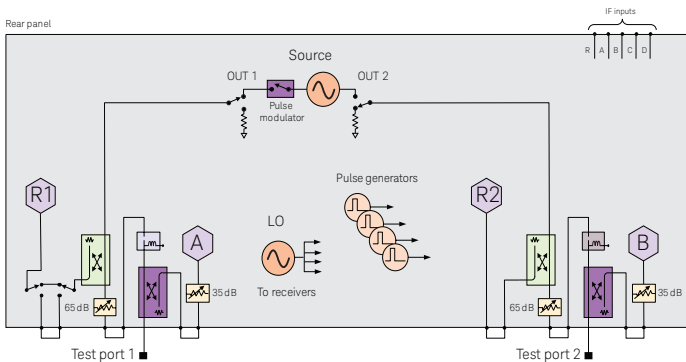

2-ports, single source, with extended power range, bias-tees, and low-frequency extension (Option 220)

Along with the front-panel access loops, bias tees, source and receiver attenuators of Option 219, Option 220 adds additional hardware to extend the start frequency of the PNA down to 900 Hz. The extended start frequency is available only for the following measurement classes: standard, gain compression (amplifier and converters), and for magnitude-only measurements using SMC (scalar mixer/converter) or SMC+Phase. In the standard channel, pulsed RF, true-mode stimulus, and source phase control are not supported for measurements below 10 MHz. The block diagram below shows how the low-frequency hardware is configured for one test port; the other test ports are configured similarly.

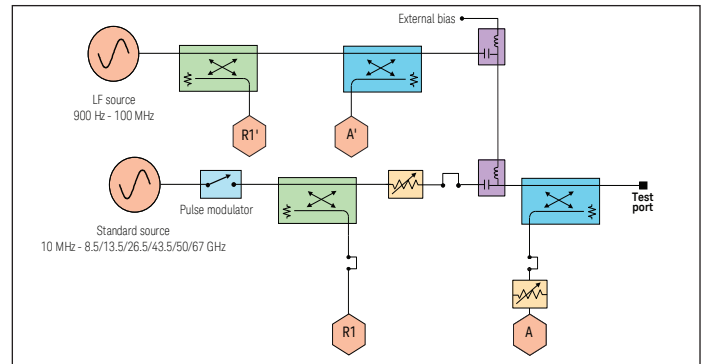

4-ports, dual source, base configuration (Option 400/410)

The 4-port with base configuration has no front-panel access loops. To independently control the frequency of the second internal source, one of the following software applications is required: S93080/029/082/083/084/086/087/089/090x/093/094B.

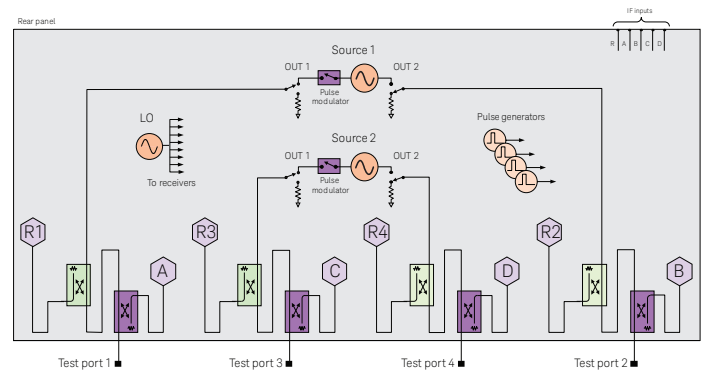

1. The block diagrams shown above include hardware that must be ordered as separate options, such as pulse modulators (Options 021 and 022), and IF access (Option 020), or is controlled by application software, as is the case for the pulse generators. In addition, the combiner type and attenuator values vary by model number. Refer to the product data sheet for the correct block diagram for a specific model.

PNA Series Test Set and Power Configuration Options ¹ (Continued)

4-ports, dual source, with configurable test set (Option 401)

The 4-port configurable test set comes with two internal sources, and twelve front-panel access loops. The loops provide access to the signal path between (a) the source output and the reference receiver, (b) the source output and directional coupler thru arm and (c) the coupled arm of the directional coupler and the port receiver at all ports. Also included is a solid-state internal RF bypass switch in the R1 reference-receiver path. To independently control the frequency of the second internal source, one of the following software applications is required: S93080/029/082/083/084/086/087/089/090x/093/094B.

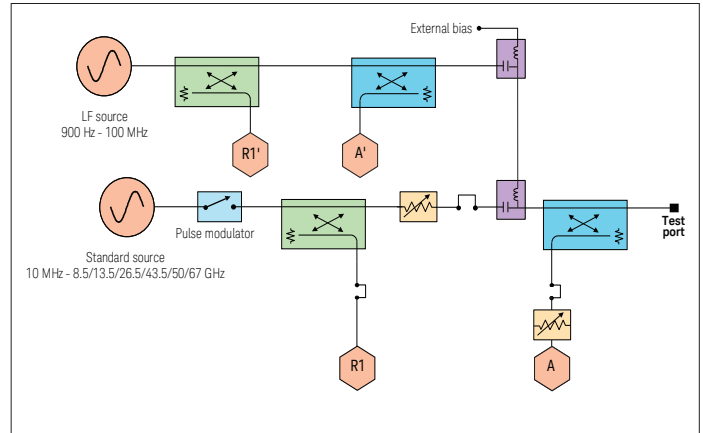

4-ports, dual source, with extended power range (Option 417)

This configuration comes with two sources, front-panel access loops, and source and receiver attenuators at each port. The source attenuators are settable in 5 dB steps up to 65 dB in N5221/22B, and in 10 dB steps up to 60 dB in N5224/25B. The receiver attenuators are settable in 5 dB steps up to 35 dB. The maximum power rating on the test port couplers is +43 dBm (additional attenuators or isolators are typically required to protect other components inside the instrument). Option 417 is not available on the N5227B. To independently control the frequency of the second internal source, one of the following software applications is required: S93080/029/082/083/084/086/087/089/090x/093/094B.

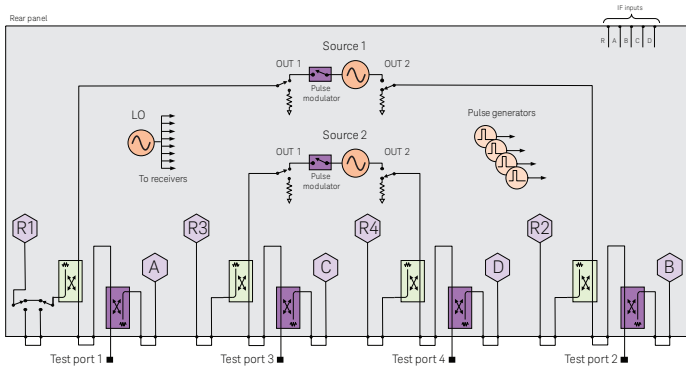

4-ports, dual source, and low-frequency extension (Option 405)

Along with the two sources, 12 front-panel access loops and R1 reference-receiver switch of option 401, Option 405 adds additional hardware to extend the start frequency of the PNA down to 900 Hz. The extended start frequency is available only for the following measurement classes: standard, gain compression (amplifier and converters), and for magnitude-only measurements using SMC (scalar mixer/converter) or SMC+Phase. In the standard channel, pulsed RF, true-mode stimulus, and source phase control are not supported for measurements below 10 MHz. The block diagram below shows how the low-frequency hardware is configured for one test port; the other test ports are configured similarly.

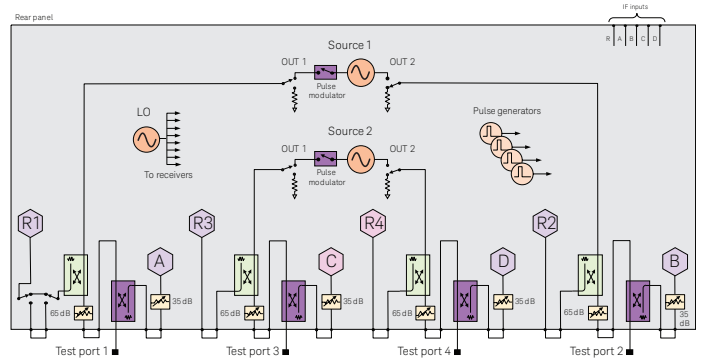

1. The block diagrams shown above include hardware that must be ordered as separate options, such as pulse modulators (Options 021 and 022), and IF access (Option 020), or is controlled by application software, as is the case for the pulse generators. In addition, the combiner type and attenuator values vary by model number. Refer to the product data sheet for the correct block diagram for a specific model.

PNA Series Test Set and Power Configuration Options ¹ (Continued)

4-ports, dual source, with extended power range and bias-tees (Option 419)

This configuration comes with two sources, front-panel access loops, and bias tees and source and receiver attenuators at each port. The source attenuators are settable in 5 dB steps up to 65 dB in N5221/22B, in 10 dB steps up to 60 dB in N5224/25B, and in 10 dB steps up to 50 dB in N5227B. The receiver attenuators are settable in 5 dB steps up to 35 dB in N5221/22/24/25B, and 10 dB steps up to 50 dB in N5227B. The bias tees are connected directly to the test port couplers, which limits the maximum power rating on the pair to +30 dBm (additional attenuators or isolators are typically required to protect other components inside the instrument). To independently control the frequency of the second internal source, one of the following software applications is required: S93080/029/082/083/084/086/087/089/090x/093/094B.

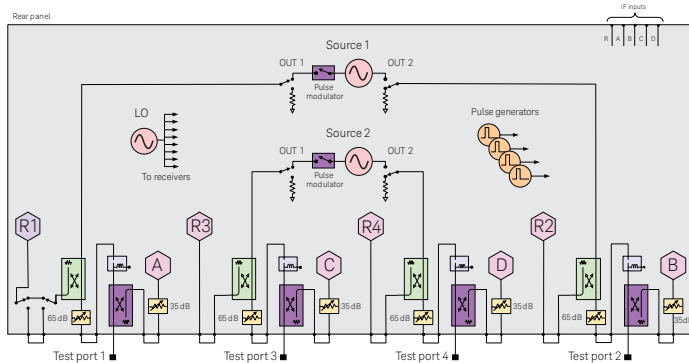

4-ports, dual source, with extended power range, bias-tees, and low-frequency extension (Option 420)

4-ports, dual source, with extended power range, bias-tees, and low-frequency extension (Option 420). Along with the two sources, front-panel access loops, bias tees, source and receiver attenuators of Option 419, Option 420 adds additional hardware to extend the start frequency of the PNA down to 900 Hz. The extended start frequency is available only for the following measurement classes: standard, gain compression (amplifier and converters), and for magnitude-only measurements using SMC (scalar mixer/converter) or SMC+Phase. In the standard channel, pulsed RF, true-mode stimulus, and source phase control are not supported for measurements below 10 MHz. The block diagram below shows how the low-frequency hardware is configured for one test port; the other test ports are configured similarly. To independently control the frequency of the second internal source, one of the following software applications is required: S93080/029/082/083/084/086/087/089/090x/093/094B.

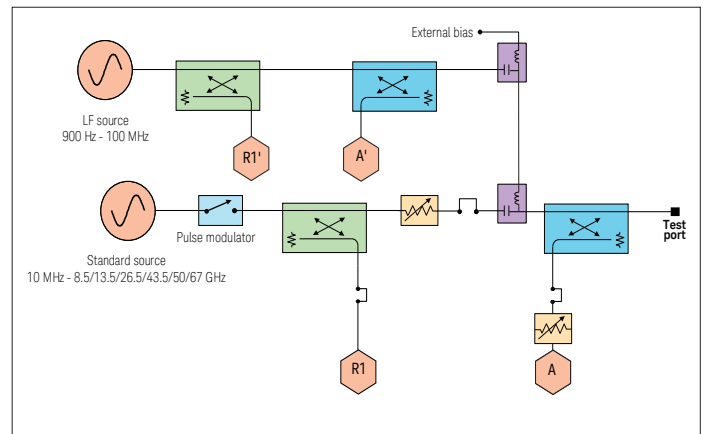

1. The block diagrams shown above include hardware that must be ordered as separate options, such as pulse modulators (Options 021 and 022), and IF access (Option 020), or is controlled by application software, as is the case for the pulse generators. In addition, the combiner type and attenuator values vary by model number. Refer to the product data sheet for the correct block diagram for a specific model.

PNA-L Series Test Set and Power Configuration Options

The PNA-L is an integrated vector network analyzer featuring a built-in S-parameter test set, one synthesized source used for device stimulus, a solid state drive, USB interfaces, and a 12.1" LCD touch screen display. The N5239B, N5231B and the N5232B have 50 ohm, ruggedized 3.5 mm (m) test ports. The N5234A and N5235B have 50 ohm, ruggedized 2.4 mm (m) test ports. Included with each instrument is a mouse, keyboard (U.S. style). For one day of on-site productivity assistance (not included with instrument purchase), request quantity 1 each PS-S20-PNA.

A test set and power configuration option is mandatory. Choose one of the following:

2 ports, single source, base configuration (Option 200)

The 2-port with base configuration has no front-panel access loops.

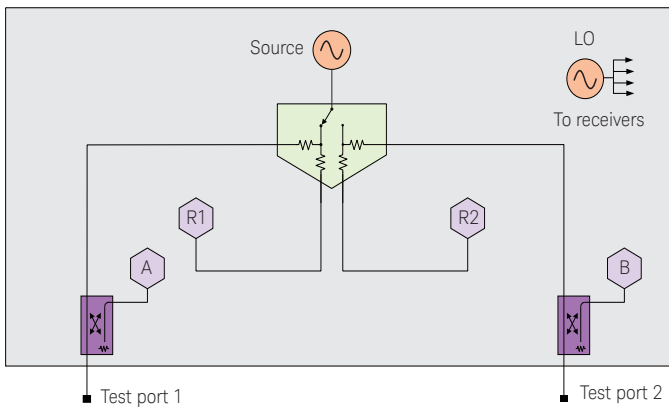

2 ports, single source, with configurable test set and source attenuators (Option 216)

The 2-port test set comes with a configurable test set and source attenuator at each port. The configurable test set adds six front-panel access loops. The loops provide access to the signal path between (a) the source output and the reference receiver, (b) the source output and directional coupler thru arm, and (c) the coupled arm of the directional coupler and the port receiver at all ports. The source attenuators are settable in 10 dB steps up to 60 dB.

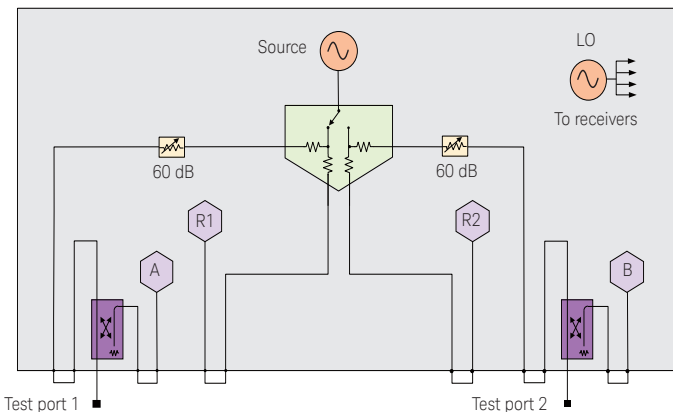

4 ports, single source, base configuration (Option 400)

The 4-port base configuration has no front-panel loops, and is available only on the N5231B and N5232B.

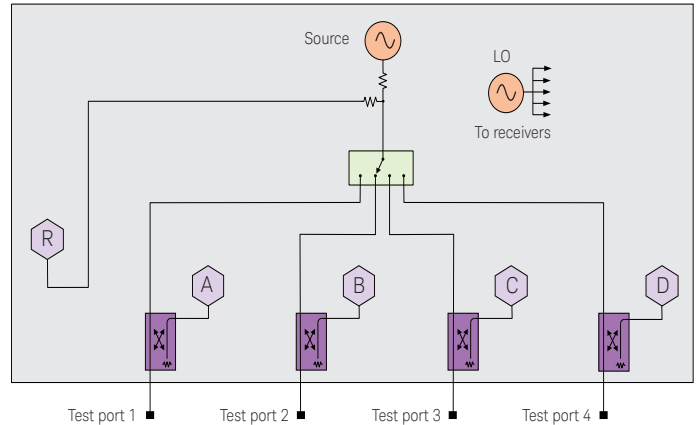

4 ports, single source, with configurable test set and source attenuator (Option 416)

The 4-port test set comes with a configurable test set and one source attenuator to be shared with all ports. The configurable test set adds nine front-panel access loops. The loops provide access to the signal path between (a) the source output and the reference receiver, (b) the source output and directional coupler thru arm at all ports, and (c) the coupled arm of the directional coupler and the port receiver at all ports. The source attenuator is settable in 10 dB steps up to 60 dB. This configuration is available only on the N5231B and N5232B.

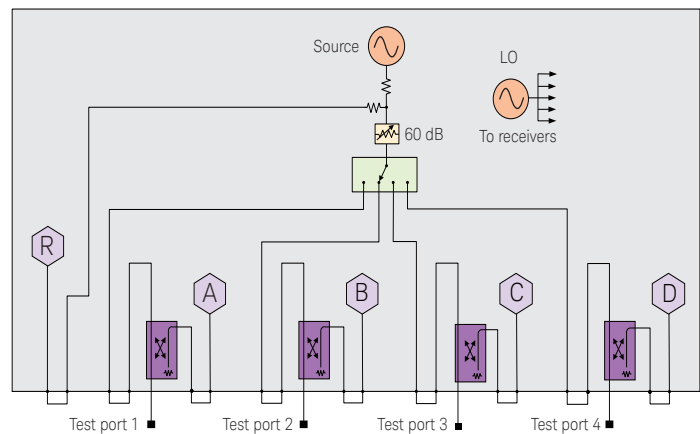

PNA Family Applications and Options

Measurement application software

Solid black series name indicates the feature is available on that series, while gray series name with strikethrough indicates the feature is not available on that series. For example:

PNA: Available on PNA Series

~~PNA~~: Not available on PNA Series

Automatic fixture removal (S93007B)

PNA-X **PNA** ~~PNA-L~~

Many devices do not have coaxial connectors and are put in fixtures in order to measure them in a coaxial environment. Accurately removing the effects of the fixture is required to get a good measurement of the device under test (DUT). This application adds a powerful application wizard to guide you through characterizing a fixture and removing it from the measurement. Devices can be single ended or differential. Files can be saved in a variety of formats for later use in PNA, ADS, and PLTS.

Time domain analysis (S93010B)

PNA-X **PNA** ~~PNA-L~~

This application enables the analyzer to view reflection and transmission responses in time or distance. Use time domain to tune filters, gate out the response of fixtures and cables, characterize the impedance of transmission lines and more. If eye-diagram analysis, the enhanced time domain analysis S93011B or high-speed interconnect testing is required, PLTS N1930B software must be used.

Enhanced time domain analysis with TDR (S93011B)²

PNA-X **PNA** ~~PNA-L~~

This application enables the analyzer to perform enhanced time domain analysis for high-speed data applications. All functionality of the S93010B are included (TDR/TDT mode). In addition, the S93011B enables more detailed measurements and evaluations, such as eye-diagram/mask modes, without adding PLTS software. Jitters and/or emphasis/equalization capabilities enables simulation of real-world signals and environment. The S93011B covers up to 67 GHz bandwidth with 6.66 psec rise time. Full calibration is available and the automatic deskew ensures easy removal of fixture and probe effects. To get the best accuracy, mechanical calibration kits or E-cal with DC option are recommended. When S93011B is used on a unit equipped with low frequency extension(LFE) function, the LFE function is disabled. If PAM4, W-element modeling, or greater than 4-ports or more detailed post proces data analysis is required, the N1930B PLTS is required.

Real time S-parameter and power measurement uncertainty (S93015B)

PNA-X **PNA** ~~PNA-L~~

The real time S-parameter and power measurement uncertainty (S93015B) provides uncertainties for both S-parameter and power measurements on the PNA-X, PNA and PNA-L. The real-time display of the uncertainty associated with power and S-parameter traces increases the confidence in the reproducibility of measurements. This allows users to implement pass/fail tests easily because now the instrument quantifies the gray region that is in between a full pass or a full fail, apply more realistic limit lines which can increase the production yield and reduce the defect percentage on the finished products. This application easily establishes a metric to quantify the quality of the measurement process, so your company's quality control procedures are simplified. It includes the uncertainty information for most Keysight calibration kits, and provides national metrology institute traceability through Keysight's calibration kits. This application also helps you to include uncertainty information for your product's specifications and data sheets.

Phase noise measurement (S930317B/S930321B)

PNA-X **PNA** ~~PNA-L~~

This application enables the analyzer to make phase noise measurements, and this allows the users to measure the absolute phase noise or residual noise of active components like frequency converter embedded-LO and amplifiers.

This application requires the analyzer equipped with Direct Digital Synthesizer (DDS) sources. (S/N prefix 6021 or after, or upgraded unit with N52xxBU-2S7 or 4S7)

PNA Family Applications and Options (Continued)

Measurement application software (Continued)

Modulation distortion (S93070xB)

PNA-X **PNA** **PNA-L**

This application with the PNA-X and a vector signal generator measures the in-channel and out-of-channel nonlinear behavior of power amplifiers under modulated stimulus conditions. It employs a new frequency-domain measurement method that quickly measures EVM, NPR and ACPR, and performs VNA calibration to make accurate measurement. The application provides a fully integrated measurement setup including the modulation signal generation and allows the users to easily configure and make the measurements.

This application is only available with PNA-X Option 22x or 42x. (Option 42x is recommended.)

There are several frequency range choices:

- S930700B to 8.5 GHz, S930701B to 13.5 GHz, S930702B to 26.5 GHz, S930704B to 43.5 GHz, S930705B to 50 GHz, and S930707B to 67 GHz.

The signal generators³ supported by this application are

- M9383/84B VXG Microwave Signal Generator, 1 MHz to 44 GHz
- N5182B MXG X-Series RF Vector Signal Generator, 9 kHz to 6 GHz
- N5172B EXG X-Series RF Vector Signal Generator, 9 kHz to 6 GHz
- N5192A/94A UXG X-Series Vector Adapter Modified Version, 10 MHz to 20 GHz, with U3039ACK1 6 GHz Reference Source or the 3rd source of 4-port PNA-X with option XSB
- M9383A PXIe Microwave Signal Generator, 1 MHz to 44 GHz
- M8190A 12 GSa/s Arbitrary Waveform Generator with E8267D PSG Vector Signal Generator
- M8190A 12 GSa/s Arbitrary Waveform Generator with an IQ mixer

1. When a comb generator is used as a phase reference for calibration and the start frequency of the measurement is less than 55 MHz, a user-supplied calibration mixer is required. For measurements between 50 GHz and 67 GHz, an additional high-pass filter is required (two back-to-back Keysight V281A waveguide-to-coax adapters recommended; must be ordered separately).
2. When the S93011B is shipped separately from the instrument, system default calibration is needed at the installation.
3. When Signal Studio is used, a waveform playback license N76xxEMBC is required for the external source. For more information, refer to Signal Studio Brochure (5989-6448EN)

Frequency offset measurements (S93080B)

PNA-X **PNA** **PNA-L**

This application enables the analyzer to set the frequency of the internal sources independently from where the receivers are tuned, and is required to configure an external source using External Device Configuration. This ability is important for measuring amplifiers, mixers, and frequency converters. The functionality provided by S93080B is also included with S93029/082/083/084/086/087/089/090x/093/094B or S94510/511B/A.

Scalar mixer/converter measurements (S93082B)

PNA-X **PNA** **PNA-L**

With a simple setup and calibration, this application delivers the highest accuracy for scalar conversion-loss/gain measurements by combining one-port and power-meter calibrations to remove mismatch errors. S93082B provides an intuitive and easy-to-use user interface for setting up mixer and converter measurements, with single or dual conversion stages. It can control the analyzer's built-in source(s) as well as external signal generators for use as LO signals. Supported external sources include the Keysight ESG, PSG, EXG, and MXG Series, as well as other SCPI-controlled signal generators. S93082B is a subset of S93083B, so they should not be installed together. S93082B is compatible with S93084B, which enables measurements of converters with internal LOs.

PNA Family Applications and Options (Continued)

Measurement application software (Continued)

Vector and scalar mixer/converter measurements (S93083B)

PNA-X **PNA** ~~PNA-L~~

This application includes the scalar mixer/converter plus phase (SMC+Phase) measurement class that provides fully calibrated conversion gain/loss, relative phase, and absolute group delay measurements of mixers and converters without the need for reference or calibration mixers. Eliminating the calibration mixer requires a U9391C/F/G comb generator¹ and an external DC power supply capable of sourcing +15 V and 300 mA for U9391C/F or 800 mA for U9391G. A vector mixer/converter measurement (VMC) class is also included for measuring the phase difference between multiple paths or devices, or for measuring phase shifts within a device. Using VMC or the comb-generator-based calibration for SMC+Phase requires an instrument with a configurable test set (i.e., has front-panel RF loops). For units without front-panel loops, SMC+Phase can be used with a calibration mixer supplied by the user. S93083B provides an intuitive and easy-to-use user interface for setting up mixer and converter measurements, with single or dual conversion stages. It can control the analyzer's built-in source(s) as well as external signal generators for use as LO signals. Supported external sources include the Keysight ESG, PSG, EXG, and MXG Series, as well as other SCPI-controlled signal generators. S93083B is a superset of S93082B, so they should not be installed together. S93083B is compatible with S93084B, which enables measurements of converters with internal LOs.

Embedded LO capability (S93084B)

PNA-X **PNA** ~~PNA-L~~

This application tunes the analyzer's receivers to the output frequency of the converter under test without the need for access to internal LOs or a common reference signal. S93084B is intended to work with S93029/082/083/086/087B measurement applications.

Gain compression measurements (S93086B)

PNA-X **PNA** ~~PNA-L~~

The gain compression application (GCA) provides input power, output power, gain, and phase at the compression point of an amplifier or frequency converter, over a specified frequency range. GCA's SMART Sweep is very fast and easy-to-use. GCA also includes a guided calibration that corrects for absolute power levels, frequency response, and mismatch errors.

Intermodulation distortion measurements (S93087B)

PNA-X **PNA** ~~PNA-L~~

The intermodulation distortion (IMD) application makes it very easy to set up and calibrate swept-IMD measurements of both amplifiers and frequency converters. It controls the frequency and power of internal and external sources and tunes the receivers to the main tones as well as the IMD products in a single measurement channel. The user can sweep either the center frequency of the two stimulus signals, the frequency spacing of the two stimulus signals about a fixed center frequency, or the power of one or both stimulus signals or the power of the LO signal. The analyzer can measure intermodulation distortion products of order 2, 3, 5, 7, or 9, and can display the associated intercept points. In addition, an IM Spectrum mode gives a spectrum-analyzer-like display for confirming or trouble-shooting measurements. Not available with PNA Options 200, 210, 400 and 410. When configured with a 2-port PNA or 2-port PNA-X with either Option 201, 217, or 219, an external signal generator and a combiner are required. When configured with a 4-port PNA or 4-port PNA-X with Option 401, 417, or 419, the two internal sources and an unused test port coupler configured as a combiner can be used for two-tone IMD measurements. When configured with PNA-X Option 22x or 42x, the two internal sources and internal combiner can be used for two-tone IMD measurements.

Source phase control (S93088B)

PNA-X **PNA** ~~PNA-L~~

This application allows users to set calibrated, arbitrary phase differences between two signal sources. The sources can be the analyzer's internal sources or external signal generators routed through the analyzer's test set. The phase difference can be fixed, or swept between two specified phase values. Option 088 also controls the relative power level between the sources using the receiver-leveling feature. Option 088 is targeted for active-load control, where the analyzer provides a precise, electronically settable impedance to the output port of a device, while gain and output power are measured. This capability can be combined with external load-pull software to create traditional load-pull power contours. Not available with PNA Options 200 and 210.

PNA Family Applications and Options (Continued)

Measurement application software (Continued)

Differential and I/Q device measurements (S93089B)

PNA-X **PNA** ~~PNA-L~~

This application combines source-phase control of multiple internal or external sources with frequency-offset mode, enabling simplified test of I/Q modulators/converters and differential mixers, and harmonic measurements of differential amplifiers. The phase difference between sources can be fixed (for example, at 90 or 180 degrees), or swept between two specified phase values. Providing accurate control of the relative phase between sources eliminates the need for hybrid couplers and baluns to create quadrature or differential signals. After achieving the desired phase alignment, the instrument's receivers can be tuned to all frequencies needed to characterize the DUT. On an I/Q modulator for example, measurements can be made of both the desired and suppressed conversion bands, along with LO leakage, harmonics and other spurious signals. Phase sweeps can be used to determine a DUT's phase imbalance versus frequency. Users can specify measurements with individual receivers or multiple receivers combined with a wide range of mathematical operators. Power measurements can employ match correction for increased accuracy. S93089B only works on 4-port PNA or PNA-X models.

Spectrum analysis (S93090xB)

PNA-X **PNA** **PNA-L**

The spectrum analyzer (SA) application adds high-performance microwave spectrum analysis to PNA-X, PNA, and PNA-L Series network analyzers. With fast stepped-FFT sweeps resulting from optimized data processing, the SA application provides quick spurious searches over broad frequency ranges. Simultaneous spectrum measurements can be done using up to five test and reference receivers. This multi-channel SA can be used with the internal swept-signal generators for efficient measurements of spurious signals emanating from mixers and frequency converters. The SA application employs source-power and receiver-response calibration as well as fixture de-embedding, providing in-fixture and on-wafer spectrum measurements with the highest level of accuracy. Accurate and fast noise power ratio (NPR) measurement capability is also included in this software application. It provides the ability of setting up and controlling of external signal generator/arbitrary waveform generators and performing the calibration of the flatness of a wideband signal and distortion signals in notches, and achieving very fast NPR measurements. It is recommended to use this option with PNA or PNA-X instruments with internal receiver attenuators to avoid receiver compression when measuring large signals. For use with PNA-L models, test set option 216 or 416 is recommended so that external attenuators can be connected via the front-panel jumpers to avoid receiver compression. The upper frequency range of the SA application is determined by the installed SA license or the stop frequency of the instrument, whichever is smaller. There are several frequency choices intended for standalone instruments: S930900B to 8.5 GHz, S930901B to 13.5 GHz, S930902B to 26.5 GHz, S930904B to 43.5 GHz, S930905B to 50 GHz, and S930907B to 67 GHz. Intended for use with analyzers configured with broadband or banded millimeter-wave extenders, several more choices are available: S930909B to 90 GHz, S93093B to 120 GHz, and S93094B for frequencies above 120 GHz.

Spectrum analysis, up to 120 GHz (S93093B)

PNA-X **PNA** ~~PNA-L~~

S93093B has all of the capability of the S93090xB spectrum analyzer application, with an upper frequency of 120 GHz. It is intended for analyzers configured with broadband or banded millimeter-wave frequency extenders, using a millimeter-wave controller. With this configuration, the analyzer's internal receiver attenuators are not in the receiver paths, so they cannot be used to reduce signal levels. External attenuators may be required to avoid compressing the receivers in the millimeter-wave frequency extenders. When using S93093B for millimeter-wave spectrum analysis, an N5261/62A or an N5292A millimeter-wave controller is required. When S93093B is installed on a standalone network analyzer, it will provide spectrum analysis up to the frequency limit of the instrument.

PNA Family Applications and Options (Continued)

Measurement application software (Continued)

Spectrum analysis, beyond 120 GHz (S93094B)

PNA-X **PNA** ~~PNA-L~~

S93094B has all of the capability of the S93090xB spectrum analyzer application, with an upper frequency limit determined solely by the broadband or banded millimeter-wave frequency extenders used in the system. With this configuration, the analyzer's internal receiver attenuators are not in the receiver paths, so they cannot be used to reduce signal levels. External attenuators may be required to avoid compressing the receivers in the millimeter-wave frequency extenders. When using S93094B for millimeter-wave spectrum analysis, an N5261/62A or an N5292A millimeter-wave controller is required. When S93094B is installed on a standalone network analyzer, it will provide spectrum analysis up to the frequency limit of the instrument.

Active hot parameters (S93110B/S93111B)

PNA-X ~~PNA~~ ~~PNA-L~~

Active hot parameters allows the PNA-X Series a more accurate method for testing Hot S-parameter, gain and output power than traditional methods by utilizing the X-parameter technology. It removes active device and system interaction to precisely calculate the active parameters and output power into a nominal 50 Ω environment. The advanced theory removes system-to-system correlation problems. S93110/111B also provides key parameters of optimal load for maximum power, maximum power delivered to optimal load, and the DUT's fundamental X-parameters. Total 14 traces (parameters) are available with various sweep types, such as frequency sweep, power sweep, or two-dimensional frequency and power sweep. Requires 4-port option configuration. LFE function is disabled when using on Option 425. S93110B covers up to the PNA-X's highest frequency. S93111B is the export-controlled version and covers up to 50 GHz on the N5247B.

True-mode stimulus (S93460B)

PNA-X **PNA** ~~PNA-L~~

S93460B provides mismatch-corrected true-mode (true differential mode and true common mode) stimulus and enables accurate balanced measurements under real operating conditions. It also provides balanced measurements with forward-only sweeps, reverse-only sweeps, and frequency or power sweeps with arbitrary phase and amplitude offsets. S93460B only works on 4-port PNA or PNA-X models.

N-port measurements (S93551B) ¹

PNA-X **PNA** **PNA-L**

S93551B adds a multiport analyzer mode, which enables full N-port error correction and measurement capabilities using an external test set. Only the standard measurement class is available in the multiport analyzer mode. Not available with PNA Options 200, 210, 400 and 410. For multiport analysis greater than 8 ports, it is highly recommended to use N1930B PLTS software to manage the large data files that grow exponentially (12 port S-parameter files have 144 S-parameter elements).

Device Measurement eXpert (DMX) (S94601B)

PNA-X **PNA** **PNA-L**

S94601B assists the users in setting up measurements automatically with customizable templates to use consistent measurement settings in different stages of design and test workflow. It supports various types of DUTs, and once the right DUT is selected, appropriate measurement parameters are listed and the users can select the parameters of interest.

It provides intelligent algorithms that optimizes measurement setups based on instrument and DUT performance limitations and protects both the DUT and the instrument.

Limit Assistant (S94602B)

PNA-X **PNA** **PNA-L**

S94602B allows the users to acquire the data from a PNA or data file in csv, s2p or prn format and easily generate limit masks for complex limit test conditions with an intuitive and convenient graphical interface for production test applications.

1. When configuring N524xB as a multiport analyzer using S93551B and a multiport test set, the combiner feature of Option 22x or 42x is temporarily disabled. When configured as a standalone analyzer, the combiner feature is enabled. When ordering a test set, select an appropriate interface kit. Refer to page 32 Multiport Measurements section for more details.

PNA Family Applications and Options (Continued)

Noise figure options and applications

Add low-noise receiver (Option 029)

PNA-X ~~PNA~~ ~~PNA-L~~

This option adds a low-noise receiver to the PNA-X to provide wideband noise figure and noise-power measurements on a broad range of devices. The noise receiver has three gain settings, and contains the necessary filters to eliminate out-of-band noise conversion. For N5241/42/49B instruments, Option 029 adds a mechanical switch at port one to allow use of an external ECal module as an impedance tuner to provide high-accuracy noise figure measurements. For N5244/45/47B instruments, Option 029 adds a built-in impedance tuner at port one with a bypass switch. The noise receiver start frequency is 10 MHz and for N5241/42/44/45/49B instruments, it works up to the stop frequency of the instrument. For N5247B instruments, the low-noise receiver and tuner work up to 50 GHz only. For noise figure measurements between 50 and 67 GHz, any of the standard network analyzer receivers can be used. Option 029 is intended for use with S93029B software. Without the software, the noise hardware cannot be utilized.

Noise figure measurements with vector correction (S93029B)

PNA-X **PNA** ~~PNA-L~~

This software application enables high-accuracy noise figure and noise-power measurements of amplifiers, frequency converters, and mixers, utilizing Keysight's unique vector-source-correction technique that uses a source-impedance tuner to remove the effects of imperfect system-source match. This approach yields accuracy that surpasses that provided by the Y-factor method and other cold-source implementations, especially for in-fixture, on-wafer, and automated-test environments. A scalar-calibrated method is also available that offers less accuracy, but is faster and does not require an impedance tuner.

If S93029B is used on a PNA-X configured with Option 029, then it makes full use of the built-in low-noise receiver. Optionally, noise figure measurements can be made using the standard receivers for high-gain (> 60 dB), narrowband devices that might otherwise overload the low-noise receiver, or for noise figure measurements between 50 and 67 GHz on the N5247B. If running on a PNA, a PNA-X without Option 029, or for measurements up to 67 GHz, then the instrument's standard receivers are used. For those cases, an external preamplifier and filter(s) is required for devices with < 30 dB of excess noise (gain plus noise figure in dB) up to 20 GHz, < 40 dB up to 50 GHz, or

< 45 dB up to 67 GHz. Instruments with front panel jumpers are recommended as they provide a convenient spot for adding a preamplifier and filter for low-gain, low-noise-figure devices. S93029B controls Keysight N46901 Series ECal modules configured as impedance tuners for use with N522xB PNA models or N5241/42/49B PNA-X models, or a built-in tuner for N5244/45/47B PNA-X models with Option 029.

For calibration, a standard mechanical cal kit or ECal module is required for the S-parameter portion of the cal (an ECal used as a tuner cannot be shared for calibration). To calibrate the low-noise receiver, either a noise source (346C or 346C-K01 recommended) or power meter is required. To calibrate a standard receiver for noise figure measurements, a power meter is required. For measurements of mixers and converters, a power meter is always required, independent of whether a noise source or power meter is used to calibrate the noise receiver. All calibration accessories must be ordered separately.

Note for units that include the low-frequency extension (LFE) which allows operation down to 900 Hz:

Below 1 GHz, the LFE bias-tee hardware may cause degradation in vector-noise-calibrated noise figure measurements. This condition can occur when using an external ECal-based tuner located in the SOURCE-OUT-CPLR-THRU front-panel loop (N5241/42/49B), or while using the internal impedance tuner (N5244/45/47B). In these cases, it is recommended to either use scalar-noise calibration with a 3 to 6 dB attenuator at the end of the port 1 test cable, or use vector-noise calibration with an ECal module placed as close to the input of the DUT as possible.

Add mechanical noise tuner control for noise figure/parameter measurements (S93027B)

PNA-X ~~PNA~~ ~~PNA-L~~

Noise figure measurements using application software S93029B utilize an ECal module as an impedance tuner to provide source-corrected noise figure and noise parameter measurements of nominally matched devices, with $\gamma\text{-opts} < 0.3$. To measure noise parameters of unmatched devices with higher $\gamma\text{-opts}$, an external tuner is needed. This application software enables control of Maury Microwave LXI tuners in place of an ECal module, extending noise parameter measurements to devices with $\gamma\text{-opts} < 0.9$. Requires application software S93029B. Refer to Maury Microwave's website for more information about compatible LXI tuners.

1. 85090 or N4430 Series ECal modules are not supported.

PNA Family Applications and Options (Continued)

PNA-X block diagrams with noise figure option

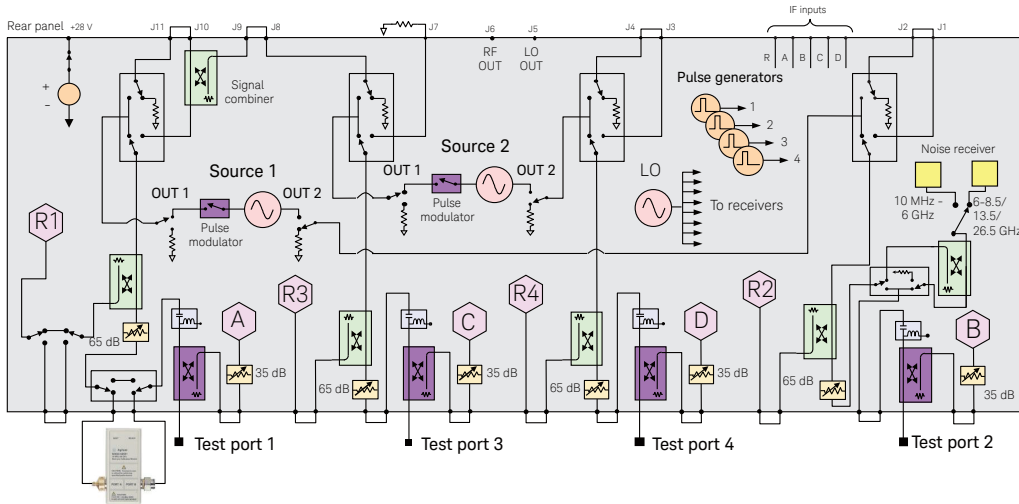

N5241/42/49B 4-port block diagram with noise figure option ¹

Impedance tuner for noise figure measurements

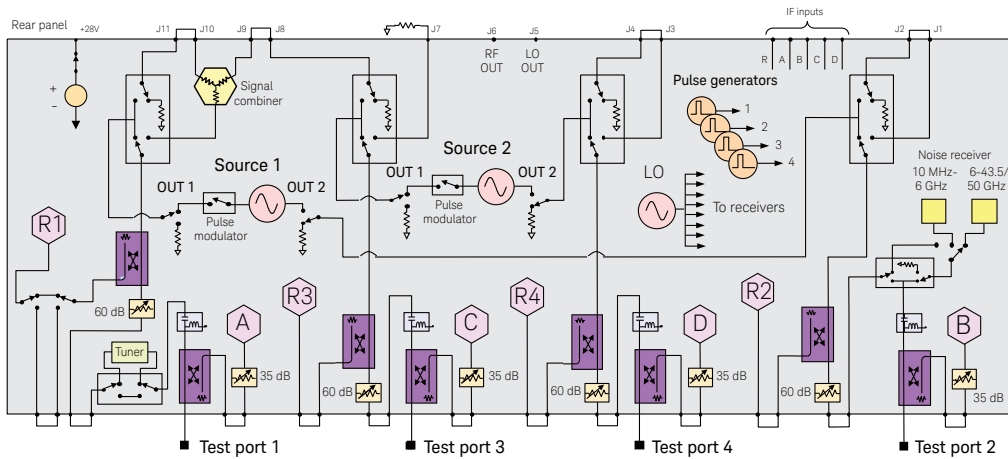

N5244/45B 4-port block diagram with noise figure option ¹

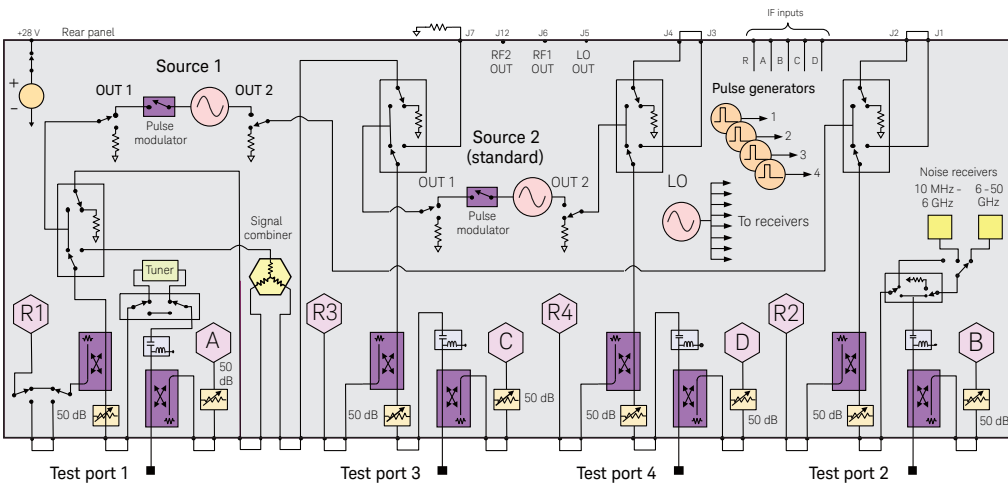

N5247B 4-port block diagram with noise figure option ¹

1. S93029B software is required to control the impedance tuner and tuner switch at port one, and the noise receiver and noise switch at port two.

PNA Family Applications and Options (Continued)

Noise figure measurement summary

Overview	S93029B without Option 029	S93029B with Option 029
Description	Noise figure application using standard receivers only, for all PNA/PNA-X models	Noise figure application using standard or low-noise receivers, for all PNA-X models
Required options	Not recommended with PNA Options 200, 210, 400, 410	For N5241/42/49B, one of Options 21x, 22x, 41x or 42x For N5244/45/47B, one of Options 22x or 42x
Includes low-noise receiver	No	Yes ¹
Includes filters for LO-harmonic rejection	No	Yes ¹
Includes source tuner bypass switch	No	Yes
Use standard receivers for noise figure measurements ²	Yes	Yes
Vector noise calibration available using ECal as tuner	Yes	Yes
Vector noise calibration using built-in tuner	No	Yes, for N5244/45/47B ¹
Recommended ECal for vector noise calibration ³	3.5 mm N4691D-MOF (N5221/22/41/42/49B) 2.4 mm N4693D-MOF (N5224/25/44/45B) 1.85 mm N4694D-MOF (N5227/47B)	3.5 mm N4691D-MOF (N5241/42/49B) Built-in for N5244/45/47B (up to 50 GHz) 1.85mm N4694D-MOF (N5247B for 50 GHz to 67 GHz)
Included tuner accessories for m-f ECal ⁴	3.5 mm N5242-20169 cable, 85052-60013 m-f adapter (N5221/22/41/42/49B) 2.4 mm N5245-20140 cable, 85056-60007 m-f adapter (N5224/25/44/45B) 1.85 mm N5247-20142 cable, 85058-60115 m-f adapter (N5227/47B)	3.5 mm N5242-20169 cable, 85052-60013 m-f adapter (N5241/42/49B) N/A for N5244/45B, due to built-in tuner 1.85 mm N5247-20142 cable, 85058-60115 m-f adapter (N5247B, for use with external 67 GHz ECal)
Recommended adapter for f-f ECal tuner (N4691D/93D/94D-F0F)	3.5 mm 85052-60014 m-m adapter (N5221/22/41/42/49B) 2.4 mm 85056-60005 m-m adapter (N5224/25/44/45B) 1.85 mm 85058-60113 m-m adapter (N5227/47B)	3.5 mm 85052-60014 m-m adapter (N5241/42/49B) N/A for N5244/45/47B, due to built-in tuner
Scalar noise calibration available	Yes	Yes
S-parameter, conversion gain/loss measurements		
Max freq (GHz)	8.5/13.5/26.5/43.5/50/67	8.5/13.5/26.5/43.5/50/67
NF measurements, amplifiers		
Max frequency, using low-noise receivers (GHz)	N/A	8.5/13.5/26.5/43.5/50
Max frequency, using standard receivers (GHz) ²	8.5/13.5/26.5/43.5/50/67	8.5/13.5/26.5/43.5/50
Calibration accessories for low-noise receivers	N/A	Cal kit or ECal, power meter/sensor. (346C or 346C-K01 noise source can be substituted for the power meter/sensor)
Calibration accessories for standard receivers	Cal kit or ECal, power meter/sensor	Cal kit or ECal, power meter/sensor

1. For N5247B, the low-noise receiver and tuner works up to 50 GHz only.

2. External preamplifier and filter(s) required if DUT excess noise (gain plus noise figure) is < 30 dB up to 20 GHz, < 40 dB up to 50 GHz, or < 45 dB up to 67 GHz.

3. Only N4690 Series ECal modules are supported for use as an impedance tuner.

4. These are supplied as accessories of PNA/PNA-X. These are not supplied with the S93029B standalone order.

PNA Family Applications and Options (Continued)

Noise figure measurement summary

Overview	S93029B without Option 029	S93029B with Option 029
NF measurements, converters		
Max DUT input frequency (GHz)	8.5/13.5/26.5/43.5/50/67	8.5/13.5/26.5/43.5/50/67
Max DUT output frequency, using low-noise receivers (GHz)	N/A	8.5/13.5/26.5/43.5/50
Max DUT output frequency, using standard receivers (GHz) ¹	8.5/13.5/26.5/43.5/50/67	8.5/13.5/26.5/43.5/50/67
Calibration accessories for low-noise receivers	N/A	Cal kit or ECal, power meter/sensor. (346C or 346C-K01 noise source is optional.)
Calibration accessories for standard receivers	Cal kit or ECal, power meter/sensor	Cal kit or ECal, power meter/sensor

1. External preamplifier and filter(s) required if DUT excess noise (gain plus noise figure) is < 30 dB up to 20 GHz, < 40 dB up to 50 GHz, or < 45 dB up to 67 GHz.

PNA Family Applications and Options (Continued)

Pulse, antenna, mm-wave applications and options

Solid black series name indicates the feature is available on that series, while the gray series name with strikethrough indicates the feature is not available on that series. For example:

PNA: Available on PNA Series
~~PNA-L~~: Not available on PNA Series

Basic pulsed-RF measurements (S93025B)

PNA-X PNA ~~PNA-L~~

This application enables four internal pulse generators that can be used to control the internal pulse modulators (Options 021 and 022), and it provides an integrated pulse application that uses the wideband-detection method. The pulse application provides an easy way to set up point-in-pulse measurements with pulse width as narrow as 200 ns, and pulse-profile measurements with 50 ns minimum timing resolution. Using the built-in pulse modulators, the PNA and PNA-X are complete pulsed-RF measurement solutions, eliminating the need for external test sets and pulse generators. S93025B also controls external pulse generators and modulators, and can synchronize to external master pulses. Option 021 is recommended for forward-only pulsed-RF measurements, and Options 021 and 022 are recommended for bi-directional pulsed-RF measurements. The N1966A Pulse I/O adapter is recommended if using external master pulses or external pulse modulators.

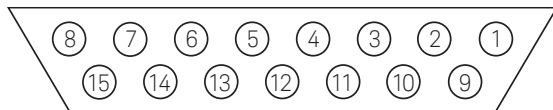

Pulse I/O D-sub connector (DB-15 female)

Advanced pulsed-RF measurements (S93026B)

PNA-X PNA ~~PNA-L~~

This application includes all of the capability of S93025B (including enabling the four internal pulse generators), and adds the narrowband-pulse-detection method to extend pulse measurement capability to 20 ns pulse widths for point-in-pulse measurements, and 10 ns timing resolution for pulse-profile measurements. With narrowband-detection mode, S93026B sets the coefficient of the analyzer's digital-IF filters to null out unwanted spectral components, enables the receiver IF gates, and performs optimization for measurement sensitivity. Using the built-in pulse modulators, the PNA and PNA-X are complete pulsed-RF measurement solutions, eliminating the need for external test sets and pulse generators. S93026B also controls external pulse generators and modulators, and can synchronize to external master pulses. Option 021 is recommended for forward-only pulsed-RF measurements, and Options 021 and 022 are recommended for bi-directional pulsed-RF measurements. The N1966A Pulse I/O adapter is recommended if using external master pulses or external pulse modulators.

Add pulse modulator to internal first source (Option 021) PNA-X PNA ~~PNA-L~~

This option enables the internal pulse modulator on Source1 Out1. Control of the modulator can be done via pin 8 of the Pulse I/O D-sub connector on the rear panel of the analyzer using an external pulse generator, or by using one of the internal pulse generators enabled with S93025/26B. The N1966A pulse I/O adapter is recommended if using an external pulse generator.

Add pulse modulator to internal second source (Option 022) PNA-X PNA ~~PNA-L~~

This option enables the internal pulse modulator on Source2 Out1. Control of the modulator can be done via pin 8 of the Pulse I/O D-sub connector on the rear panel of the analyzer using an external pulse generator, or by using one of the internal pulse generators enabled with S93025/26B. The N1966A pulse I/O adapter is recommended if using an external pulse generator. Requires one of text set options 22x or 4xx.

Add IF inputs for antenna and millimeter-wave (Option 020) PNA-X PNA ~~PNA-L~~

This option enables external IF inputs on the rear panel of the analyzer for applications such as antenna test and for use with millimeter-wave test set controllers (for more information about millimeter-wave network analyzer configurations, see Millimeter-Wave Network Analyzers Technical Overview, 5989-7620EN).

Fast CW sweep (S93118B)

PNA-X PNA ~~PNA-L~~

This option uses a FIFO (first-in first-out) buffer to allow external point-trigger acquisition of 400,000 data points per second on five measurement receivers. When enabled, there is no display update, no background computation, or other interference from the vector network analyzer application. All the data gathered is placed into a 500-million-point FIFO buffer. Data may be read from the FIFO buffer at the same time as it is filled.

Nonlinear vector network analysis

Please refer to 5989-8575EN *Nonlinear Vector Network Analyzer Brochure* for more information.

Keysight Software Licensing Options Provide Flexibility and Support

Projects ramp up and down, teams grow and shrink, and projects move location. In such a dynamic environment, you need flexible licensing options that allow you to balance your project's requirements. Whether your software will be a staple for years to come or you have a short-term need for a leading-edge measurement application, Keysight's licensing puts you in charge.

Choose your term. Choose your type. Keep control of your budget.

- Select a node-locked, transportable, USB portable or floating license type, depending on how much flexibility you need.
- Select a time-based or perpetual license term, depending on how long you need to use the software.
- Each license is sold with a KeysightCare software support subscription which provides technical support with ensured response time, proactive software updates, and enhancements.

Choose a license term and type that best suits your requirements from the table below.

Table 1. License term

License term	Options
Perpetual	Perpetual licenses can be used indefinitely.
Time-based	Time-based licenses can be used through the term of the license (6, 12, 24, or 36 months).

Table 2. License type

License type	Descriptions
Node locked	License can be used on one specified instrument/computer.
Transportable	License can be used on one instrument/computer at a time but may be transferred to another using Keysight Software Manager (internet connection required).
USB portable	License can be used on one instrument/computer at a time but can be transferred to another using a certified USB dongle (available for additional purchase, Keysight part number E8900-D10).
Floating	Networked instruments/computers can access a license from a server one at a time. Multiple licenses may be purchased for concurrent usage. Three types of floating license are available: <ul style="list-style-type: none">– Single Site: 1-mile radius from the server– Single Region!: Americas, Europe, Asia– Worldwide (export restriction identified in End User License Agreement (EULA))

1. Americas (North, Central, and South America, Canada); Europe (European Continent, Middle Eastern Europe, Africa, India); Asia (North and South Asia Pacific Countries, China, Taiwan, Japan)

KeysightCare Software Support Subscription provides peace of mind amid evolving technologies.

- Ensure your software is always current with the latest enhancements and measurement standards.
- Gain additional insight into your measurement problems with live access to our team of technical experts.
- Stay on schedule with fast turnaround times and priority escalations when you need support.

Table 3. KeysightCare software support subscription

Subscription	Descriptions
KeysightCare software support subscription	Perpetual licenses are sold with a 12 (default), 24, 36, or 60-month software support subscription. Support subscriptions may be renewed for a fee after that.
	Time-based licenses include a software support subscription through the term of the license.

Keysight Software Ordering Information

- Step 1. Choose your software product.
- Step 2. Choose your license term: perpetual or time based.
- Step 3. Choose your license type: node-locked, transportable, USB portable, or floating.
- Step 4. Depending on the license term, choose your support subscription duration.

Product	License Type	License Term			
		License	Perpetual		Time-based
S93xxxB/S94xxxB	Node-locked (fixed)	R-A5A-001-A	+	R-A6A-001-z	R-A4A-001-z
	Transportable	R-A5A-004-D	+	R-A6A-004-z	R-A4A-004-z
	USB Portable ¹	R-A5A-005-E	+	R-A6A-005-z	R-A4A-005-z
	Floating (single site)	R-A5A-002-B	+	R-A6A-002-z	R-A4A-002-z
	Floating (single region)	R-A5A-006-F	+	R-A6A-006-z	R-A4A-006-z
	Floating (worldwide)	R-A5A-010-J	+	R-A6A-010-z	R-A4A-010-z
			z = subscription duration		z = subscription duration
			L 12 months (default) ²		F 6 months
			X 24 months		L 12 months
			Y 36 months		X 24 months
			Z 60 months		Y 36 months

1. USB portable license requires a certified USB dongle (available for additional purchase, Keysight part number E8900-D10).
2. For S93xxxB/S945xxB software, the fixed-perpetual with a 12-months, support subscription (R-A6A-001-L) is the only license type that can be ordered as part of the instrument and installed. The other license types for S93xxxB/S945xxB software and all license types for S94601B/2B must be ordered separately and installed from the web after the receipt of the instrument.

Applications

Material measurements

The Keysight N1500A materials measurement suite streamlines the process of measuring complex permittivity and permeability with a network analyzer. Various type of measurements, such as transmission line and free space, arch reflectivity, resonant cavity, and coaxial probe are available as options. The easy-to-use software guides the user through setup and measurement, instantly converting S-parameter network analyzer data into the data format of your choice and displaying the results within seconds. Results can be charted in a variety of formats: ϵ_r' , ϵ_r'' , $\tan\delta$, μ_r' , μ_r'' , $\tan\delta_\mu$, and Cole-Cole.

Signal integrity measurements

N1930B Physical Layer Test System (PLTS) Software

The PLTS software platform has become an industry standard for calibration, measurement, and analysis of linear passive interconnects such as cables, connectors, backplanes, and printed circuit boards. Utilizing either a vector network analyzer (VNA) or a time domain reflectometer (TDR), fast and accurate measurements can be obtained without in-depth knowledge of microwave measurement techniques. Refer to www.keysight.com/find/plts or the technical overview (literature number 5989-6841EN) for more details.

Multiport measurements

Multiport test sets are designed to work with the PNA family of network analyzers to provide a single set of connections to devices with more than four ports. Test sets come with different port counts and frequency ranges, and are built to work with 2- or 4-port network analyzers. They are configured as switching or extension test sets, using electro-mechanical or solid-state switches.

Test set types: switching and extension

Switching test sets provide an economical solution for RF applications. They are connected directly to the front panel access ports of the VNA, and a group of test ports share the directional couplers and receivers in the VNA. Extension test sets are connected to the sources and test receivers through the configurable test set of the VNA. They feature a directional coupler for every test port, and all switching occurs behind the directional couplers, providing the ultimate in flexibility, stability, and performance for RF and microwave applications.

Note: When connected to the analyzer, the test set will degrade the analyzer performance. The internal RF switches reduce test port power to the receivers, especially for solid state test sets. this affects the test port and reduces system dynamic range. Refer to the test set user's guide for more details.

Switch types: electro-mechanical and solid-state

Electro-mechanical switches have less insertion loss, higher power handling, and a more linear response compared to solid-state switches. They are recommended for testing active devices, high-power devices, and devices that require wide dynamic range. However, they have limited switching life (mostly 5 million cycles) and long setting times. In contrast, solid-state switches have unlimited switching life, very fast switching speed, and excellent repeatability. Thus, they are often used for high-volume S-parameter measurements of passive devices.

Test set model number

Multiport test set model numbers represent the type of test set; note the numbering scheme below.

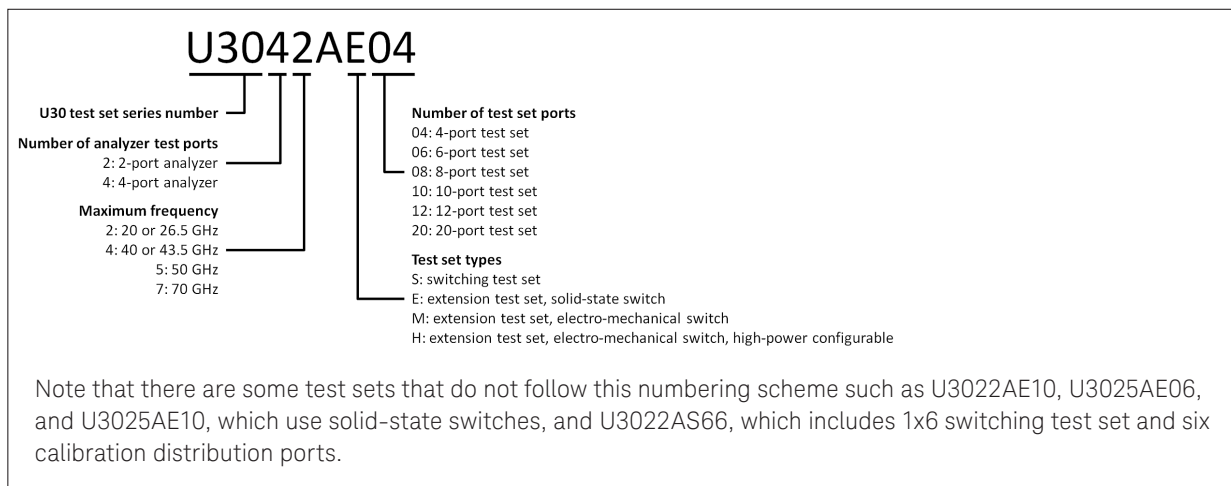

Applications (Continued)

Test set options

One of the following test set options must be selected.

Standard configuration (Option 700)

- The standard configuration is the basic test set configuration, which does not include signal conditioning devices such as amplifiers.

Add amplifiers for improved dynamic range (Option 001)

- Option 001 adds an amplifier between each test port coupler and the receiver switch to improve system dynamic range. It is primarily offered for test sets with solid-state switches, to compensate for insertion loss.

Add amplifiers and bias-tees (Option 002)

- Option 002 adds an amplifier between each test port coupler and the receiver switch to improve system dynamic range, and adds bias-tees for all test ports on the test set as well as the analyzer. It is primarily offered for test sets with solid-state switches to compensate for insertion loss.

Interface kits

The interface kit includes a set of semi-rigid RF jumper cables and two pairs of rear locking feet that connect and lock the analyzer and the test set together. When ordering a multiport test set, the analyzer that is used with the test set must be specified to add one of the following interface kits. The availability depends on the test set model. There are following three interface kit models based on the jumper connector layouts on the test set. Therefore, only one interface kit model (“PX”, “PN”, or “PL”) is available on each test set. Each interface kit model has one digit suffix indicating the connector type; 1 for 1.85 mm, 2 for 2.4 mm and 3 for 3.5 mm (or SMA).

U3021PXx	Interface kit for test set with jumper connectors to align with N524xB PNA-X and N522xB PNA
U3021PNx	Interface kit for test set with jumper connectors to align with E836xB/C PNA and N5230A/C-x25 2-port PNA-L
U3021PLx	Interface kit for test set with jumper connectors to align with N523xA/B-416 4-port PNA-L
Option 430	For use with N5230A/C-425/426 or N523xA/B-416
Option 242	For use with N5221/22/41/42/49B-2xx 2-port PNA/PNA-X
Option 442	For use with N5221/22/41/42/49B-4xx 4-port PNA/PNA-X
Option 245	For use with N5224/25/44/45B-2xx 2-port PNA/PNA-X
Option 445	For use with N5224/25/44/45B-4xx 4-port PNA/PNA-X
Option 247	For use with N5227/47B-2xx 2-port PNA/PNA-X
Option 447	For use with N5227/47B-4xx 4-port PNA/PNA-X

Millimeter-wave measurements

N5290/91A single-sweep millimeter-wave solutions

PNA (N522xB) and PNA-X (N524xB) network analyzers can be transformed into single-sweep solutions that operate from 900 Hz to 110 GHz (N5290A), or up to 120 GHz with over-range capability to 125 GHz (N5291A). The N5290/91A solutions come fully configured around the PNA/PNA-X network analyzers, and include a millimeter-wave test set controller (N5292A), frequency-extender modules (N5293/95AXxx), and the necessary cables to allow users to make either 2- or 4-port measurements over the entire frequency range. The broadband N5290/91A millimeter-wave solutions provide high-performance measurement capability complimented by measurement applications from the PNA/PNA-X that include pulsed-RF, gain compression, 4-port true-differential, scalar mixer/converter measurements, and spectrum analysis.

Banded waveguide solutions to 1.5 THz

Banded waveguide millimeter-wave solutions cover waveguide bands from 50 GHz to 1.5 THz. A 2- or 4-port PNA or PNA-X in conjunction with an N5292A millimeter-wave controller (with either a 2- or 4-port option), provides complete millimeter-wave solutions. These systems are configured with a PNA or PNA-X which has IF inputs (Option 020), and a configurable test set (one of Options 201/217/219/222/224/401/417/419/422/42). In addition, frequency-offset capability is required from one of software models 93029/080/082/083/084/086/087/089/090x/093/094B. When configured with the N5292A millimeter-wave controller, a special cable adapter will be required to connect the RF, LO, and IF signals from the banded millimeter-wave extenders to the controller. A separate DC power supply is also required to power the frequency extenders.

For a complete list of millimeter-wave products and options, and ordering instructions, please refer to the N5290/91A Millimeter-Wave Network Analyzer Configuration Guide (5992-2179EN), and the Banded Millimeter-Wave Network Analyzers to 1.5 THz Technical Overview (5992-2177EN).

When ordering an additional cable set, a spare cable or rear locking feet, refer to the multiport test set user's guide or go to: www.keysight.com/find/multiport

Applications (Continued)

Measurement Accessories

A complete list of RF and microwave test accessories is available on our Web site: www.keysight.com/find/mta

Accessories are available in these connector types: 7-16, 4.3-10, Type-N 50 Ω , 3.5 mm, 7 mm, 2.4 mm, 2.92 mm, 1.85 mm, 1.0 mm, and waveguide. Test port cables and a calibration kit should be added for a complete measurement system. A verification kit is used to verify corrected system performance.

Cables and adapter sets

Keysight offers cables in the following types:

- Single cables in semi-rigid and flexible
- Cable sets in semi-rigid and flexible

There are also adapter sets available that protect the test port and convert the port to the desired connector interface. These kits contain:

- One male adapter
- One female adapter

To attain the best mechanical rigidity for device connection, use a single cable and the appropriate special adapter set. To attain the greatest flexibility for device connection, use a cable set.

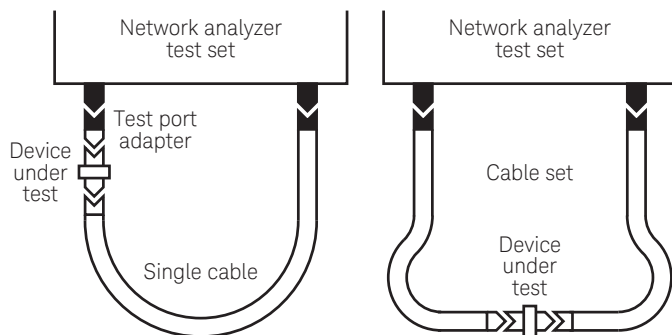

Calibration kits

Coaxial measurements

Mechanical calibration kits include standards, such as opens, shorts and loads, which are measured by the network analyzer for increased measurement accuracy.

Choose a calibration kit for each connector type to be used.

Economy, includes:

- Open standards (male and female)
- Short standards (male and female)
- Fixed-termination standards (male and female)

Standard, includes the devices in the economy kit and adds:

- Sliding load standards (male and female) or a series of offset shorts

Precision, includes the devices in the economy kit and adds:

- 50 Ω airline(s) for TRL calibration
- TRL adapters

Electronic calibration (ECal) kits replace mechanical calibration standards with one solid-state calibration module that is controlled by the network analyzer via USB, to present many different impedances to the test ports. A full two-port calibration can be performed quickly with a single connection. This technique reduces operator errors and connector wear and abrasion.

For more information about ECal modules, refer to the technical overview 5963-3743E (N4690, 85090, N4430 and N7550 Series).

Waveguide measurements

For waveguide measurements, Keysight offers mechanical calibration kits that include:

- Waveguide-to-coax adapters (X, P, K, R, Q, U, V)
- Precision waveguide section
- Flush short circuit
- Fixed terminations
- Straight section

For devices with 1.0 mm connectors

Mechanical calibration/verification kit

85059B DC to 120 GHz precision calibration kit. Includes:

- 85059-60027 1.0 mm (m) short, 1.3 mm
- 85059-60029 1.0 mm (m) short, 2.45 mm
- 85059-60031 1.0 mm (m) short, 3.326 mm
- 85059-60033 1.0 mm (m) short, 4.039 mm
- 85059-60028 1.0 mm (f) short, 1.3 mm
- 85059-60030 1.0 mm (f) short, 2.45 mm
- 85059-60032 1.0 mm (f) short, 3.326 mm
- 85059-60034 1.0 mm (f) short, 4.039 mm
- 85059-60053 1.0 mm (m) open
- 85059-60054 1.0 mm (f) open
- 85059-60019 1.0 mm (m) 50 GHz load
- 85059-60020 1.0 mm (f) 50 GHz load
- 85059-60044 1.0 mm m-m adapter
- 85059-60045 1.0 mm f-f adapter
- 85059-60046 1.0 mm m-f adapter
- 8710-2812 6 mm 4 in-lb torque wrench
- 8710-2813 14 mm 4 in-lb torque wrench
- 8710-2156 6 mm open-end wrench

Cables

- 11500I 1.0 mm (f-f) test port cable (8.8 cm)
- 11500JK10 110 GHz, 1.0 mm (m-f) test port cable (10 cm)
- 11500J 1.0 mm (m-f) test port cable (16.0 cm)¹
- 11500K 1.0 mm (m-f) test port cable (20.0 cm)¹
- 11500L 1.0 mm (m-f) test port cable (24.0 cm)¹

Adapter set

- V281C 1.0 mm (f) to V-band waveguide adapter
- V281CS 1.0 mm (f) to V-band waveguide adapter, In-line²
- V281D 1.0 mm (m) to V-band waveguide adapter
- V281DS 1.0 mm (m) to V-band waveguide adapter, In-line²
- V281ES Ruggedized 1.0 mm (m) to V-band waveguide adapter, In-line³
- E281CS 1.0 mm (f) to E-band waveguide adapter, In-line²
- E281DS 1.0 mm (m) to E-band waveguide adapter, In-line²
- E281ES Ruggedized 1.0 mm (m) to E-band waveguide adapter, In-line³
- W281C 1.0 mm (f) to W-band waveguide adapter
- W281CS 1.0 mm (f) to W-band waveguide adapter, In-line²
- W281D 1.0 mm (m) to W-band waveguide adapter
- W281DS 1.0 mm (m) to W-band waveguide adapter, In-line²
- W281ES Ruggedized 1.0 mm (m) to W-band waveguide adapter, In-line³

- Y1910A 1.0 mm (m) to 1.0 mm (m) adapter
- Y1910B 1.0 mm (f) to 1.0 mm (f) adapter
- Y1910C 1.0 mm (m) to 1.0 mm (f) adapter
- 11921E 1.0 mm (m) to 1.85 mm (m) adapter
- 11921F 1.0 mm (f) to 1.85 mm (f) adapter
- 11921G 1.0 mm (m) to 1.85 mm (f) adapter
- 11921H 1.0 mm (f) to 1.85 mm (m) adapter
- 11922A 1.0 mm (m) to 2.4 mm (m) adapter
- 11922B 1.0 mm (f) to 2.4 mm (f) adapter
- 11922C 1.0 mm (m) to 2.4 mm (f) adapter
- 11922D 1.0 mm (f) to 2.4 mm (m) adapter
- 11923A 1.0 mm (f) connector launch assembly

For devices with 1.85 mm connectors

Mechanical calibration kit

85058B standard: DC to 67 GHz. Includes:

- 85058-60101 1.85 mm (m) short 5.4 mm
- 85058-60102 1.85 mm (m) short 6.3 mm
- 85058-60103 1.85 mm (m) short 7.12 mm
- 85058-60104 1.85 mm (m) short 7.6 mm
- 85058-60105 1.85 mm (f) short 5.4 mm
- 85058-60106 1.85 mm (f) short 6.3 mm
- 85058-60107 1.85 mm (f) short 7.12 mm
- 85058-60108 1.85 mm (f) short 7.6 mm
- 85058-60109 1.85 mm male open
- 85058-60110 1.85 mm female open
- 85058-60111 1.85 mm male load
- 85058-60112 1.85 mm female load
- 85058-60113 1.85 mm (m) to 1.85 mm (m) adapter
- 85058-60114 1.85 mm (f) to 1.85 mm (f) adapter
- 85058-60115 1.85 mm (m) to 1.85 mm (f) adapter

85058E economy: DC to 67 GHz. Includes:

- 85058-60101 1.85 mm (m) short 5.4 mm
- 85058-60105 1.85 mm (f) short 5.4 mm
- 85058-60109 1.85 mm male open
- 85058-60110 1.85 mm female open
- 85058-60123 1.85 mm male load
- 85058-60124 1.85 mm female load
- 85058-60113 1.85 mm (m) to 1.85 mm (m) adapter
- 85058-60114 1.85 mm (f) to 1.85 mm (f) adapter
- 85058-60115 1.85 mm (m) to 1.85 mm (f) adapter

1. For on-wafer applications, two 11500J/K/L cables are required; one cable for each test port.
2. Supplied by SAGE Millimeter Inc.
3. Supplied by Spinner Inc.

For devices with 1.85 mm connectors (Continued)

Electronic calibration kits

N4694D¹ Microwave ECal: DC or 10 MHz to 67 GHz, 2-ports.

Includes:

- Option F0F: Both connectors are 1.85 mm female on module
- Option M0F: 1 female and 1 male 1.85 mm connector on module
- Option M0M: Both connectors are 1.85 mm male on module
- Option 0DC: DC to 67 GHz
- Option 100: 10 MHz to 67 GHz
- Option 00A adds:
 - 85058-60113 1.85 mm (m) to 1.85 mm (m) adapter
 - 85058-60114 1.85 mm (f) to 1.85 mm (f) adapter

Cables

- N4697J² Single, flexible cable up to 70 GHz:
 - 1.85 mm (f) to 1.85 mm (f), 96.5 cm, 38 inches
- N4697E² Single, flexible cable up to 67 GHz:
 - 1.85 mm (f) to 1.85 mm (f), 96.5 cm, 38 inches
- N4697K² Flexible cable set up to 70 GHz:
 - one 1.85 mm (f) to 1.85 mm (f) cable, 62.2 cm, 24.5 inches and one 1.85 mm (f) to 1.85 mm (m) cable, 62.2 cm, 24.5 inches
- N4697F² Flexible cable set up to 67 GHz:
 - one 1.85 mm (f) to 1.85 mm (f) cable, 62.2 cm, 24.5 inches and one 1.85 mm (f) to 1.85 mm (m) cable, 62.2 cm, 24.5 inches

Adapter set

- 85130H² 1.85 mm to 1.85 mm

For devices with 2.4 mm connectors

Mechanical calibration kit

85056A standard: DC to 50 GHz. Includes:

- 00901-60003 2.4 mm (m) fixed broadband load
- 00902-60004 2.4 mm (f) fixed broadband load
- 00915-60003 2.4 mm (m) sliding load
- 00915-60004 2.4 mm (f) sliding load
- 85056-60005 2.4 mm (m) to 2.4 mm (m) adapter
- 85056-60006 2.4 mm (f) to 2.4 mm (f) adapter
- 85056-60007 2.4 mm (m) to 2.4 mm (f) adapter
- 85056-60020 2.4 mm (m) short
- 85056-60021 2.4 mm (f) short
- 85056-60022 2.4 mm (m) open
- 85056-60023 2.4 mm (f) open

– 85056D economy: DC to 50 GHz. Includes:

- 00901-60003 2.4 mm (m) fixed broadband load
- 00902-60004 2.4 mm (f) fixed broadband load
- 85056-60005 2.4 mm (m) to 2.4 mm (m) adapter
- 85056-60006 2.4 mm (f) to 2.4 mm (f) adapter
- 85056-60007 2.4 mm (m) to 2.4 mm (f) adapter
- 85056-60020 2.4 mm (m) short
- 85056-60021 2.4 mm (f) short
- 85056-60022 2.4 mm (m) open
- 85056-60023 2.4 mm (f) open

Electronic calibration kits

N4693D¹ Microwave ECal: DC or 10 MHz to 50 GHz, 2-ports.

Includes:

- Option F0F: Both connectors are 2.4 mm female on module
- Option M0F: 1 female and 1 male 2.4 mm connector on module
- Option M0M: Both connectors are 2.4 mm male on module
- Option 0DC: DC to 50 GHz
- Option 100: 10 MHz to 50 GHz
- Option 00A adds:
 - 85056-60005 2.4 mm (m) to 2.4 mm (m) adapter
 - 85058-60006 2.4 mm (f) to 2.4 mm (f) adapter

1. The PNA Series must have firmware revision A.12.85.00 or above for operation with the N469xD Series ECal.
2. Special rugged female connector specifically for connecting to the network analyzer test port, but does not mate with a standard male connector. The N4697J/K will replace the N4697E/F, which will be discontinued on December 1, 2021.

For devices with 2.4 mm connectors (Continued)

Cables

Note: Keysight offers the following 2.4 mm test port cables. Adapters will be necessary when using these cables for 2.92 mm measurements.

- 85133C¹ single, semi-rigid: 2.4 mm (f) to PSC-2.4 mm (f), 81 cm, 32 inches
- 85133D¹ set, semi-rigid: One 2.4 mm (f) to 2.4 mm (m), 53 cm, 21 inches, p/n 85133-60001
- One 2.4 mm (f) to 2.4 mm (f), 53 cm, 21 inches, p/n 85133-60002
- 85133E¹ single, flexible: 2.4 mm (f) to PSC-2.4 mm (f), 97 cm, 38 inches
- 85133F¹ set, flexible:
 - One 2.4 mm (f) to 2.4 mm (f), 63 cm, 25 inches, p/n 85133-60016
 - One 2.4 mm (f) to 2.4 mm (m), 63 cm, 25 inches, p/n 85133-60017
- 85133H¹ Single, flexible: 2.4 mm (f) to 2.4 mm (m), 63 cm, 25 inches
- N4421AK20 Single, flexible: 2.4 mm (f) to 2.4 mm (m), 91.4 cm, 36 inches

Adapter set

- 85130E 2.4 mm¹ to 7 mm
- 85130F 2.4 mm¹ to 3.5 mm
- 85130G 2.4 mm¹ to 2.4 mm

1. Special rugged female connector specifically for connecting to the network analyzer test port, but does not mate with a standard male connector.
2. Special rugged female connector specifically for connecting to the network analyzer test port, but does not mate with standard 2.4 mm male connector.

For devices with K connectors (2.92 mm)

Mechanical calibration kits

85056KE01 DC to 40 GHz

For use with user supplied 2.92 mm test port cables. 2.92 mm (K connector) calibration kit with fixed and sliding loads. The Keysight 85056KE01 calibration kit is an ordering convenience to allow the pass through ordering from Keysight for the Maury 8770E47 calibration kit.

85056KE02 DC to 40 GHz

For use with user supplied 2.92 mm test ports cables. 2.92 mm (K connector) calibration kit with fixed loads only. The Keysight 85056KE02 calibration kit is an ordering convenience to allow the pass through ordering from Keysight for the Maury 8770F47 calibration kit.

The 85056KE01 and 85056KE02 contains one NMD 2.4 mm² (f) to 2.92 mm (f) and one NMD 2.4 mm² (f) to 2.92 mm (m) test port adapter to adapt the 2.4 mm test ports of the PNA to 2.92 mm. It also supplies 2.92 mm to 2.92 mm in-series adapters (3 adapters) and a PNA Cal Coefficients on a USB stick. Users must supply their own 2.92 mm or K-connector test port cables. Also included is a 2.92 mm torque wrench.

Maury Microwave Terms and Conditions for Warranty and Return apply. Maury Microwave Corp. calibration kits are to be returned directly to Maury Microwave for service, repair, or calibration issues and not to Keysight Technologies. For additional information go to www.maurymicrowave.com.

Keysight Technologies does not guarantee the performance of the Maury calibration kits or the system performance when connected to Keysight Microwave PNA Series network analyzers.

For devices with K connectors (2.92 mm) (Continued)

Mechanical calibration kits, continued

Electronic calibration kits

N4692D¹ Microwave ECal: DC or 10 MHz to 40 GHz, 2-ports.

Includes:

- Option F0F: Both connectors are 2.92 mm female on module
- Option M0F: 1 female and 1 male 2.92 mm connector on module
- Option M0M: Both connectors are 2.92 mm male on module
- Option 0DC: DC to 40 GHz
- Option 100: 10 MHz to 40 GHz
- Option 00A adds:
 - N4692-60021 2.92 mm (m) to 2.92 mm (m) adapter
 - N4692-60022 2.92 mm (f) to 2.92 mm (f) adapter

Cables

Note: Keysight offers the following 2.4 mm test port cables. Adapters will be necessary when using these cables for 2.92 mm measurements.

- 85133C² single, semi-rigid: 2.4 mm (f) to PSC-2.4 mm (f), 81 cm, 32 inches
- 85133D² set, semi-rigid:
 - One 2.4 mm (f) to 2.4 mm (m), 53 cm, 21 inches, p/n 85133-60001
 - One 2.4 mm (f) to 2.4 mm (f), 53 cm, 21 inches, p/n 85133-60002
- 85133E² single, flexible: 2.4 mm (f) to PSC-2.4 mm (f), 97 cm, 38 inches
- 85133F² set, flexible:
 - One 2.4 mm (f) to 2.4 mm (f), 63 cm, 25 inches, p/n 85133-60016
 - One 2.4 mm (f) to 2.4 mm (m), 63 cm, 25 inches, p/n 85133-60017
- 85133H² Single, flexible: 2.4 mm (f) to 2.4 mm (m), 63 cm, 25 inches
- N4421AK20 Single, flexible: 2.4 mm (f) to 2.4 mm (m), 91.4 cm, 36 inches

Adapters

- 11904A 2.4 mm (m) to 2.92 mm (m)
- 11904B 2.4 mm (f) to 2.92 mm (f)
- 11904C 2.4 mm (m) to 2.92 mm (f)
- 11904D 2.4 mm (f) to 2.92 mm (m)
- 11904S 2.4 mm to 2.92 mm
- Adapter set, contains 4 matched adapters

1. The PNA Series must have firmware revision A.12.85.00 or above for the operation with the N469xD Series ECal.
2. Special rugged female connector specifically for connecting to the network analyzer test port, but does not mate with a standard male connector.

For devices with 3.5 mm or SMA connectors

Mechanical calibration kits

85052B standard: DC to 26.5 GHz. Includes:

- 00902-60003 3.5 mm (m) fixed load
- 00902-60004 3.5 mm (f) fixed load
- 00911-60019 3.5 mm (m) sliding load
- 00911-60020 3.5 mm (f) sliding load
- 85052-60006 3.5 mm (m) short
- 85052-60007 3.5 mm (f) short
- 85052-60008 3.5 mm (m) open
- 85052-60009 3.5 mm (f) open
- 85052-60012 3.5 mm (f) to 3.5 mm (f) adapter
- 85052-60013 3.5 mm (f) to 3.5 mm (m) adapter
- 85052-60014 3.5 mm (m) to 3.5 mm (m) adapter

85052C precision TRL: DC to 26.5 GHz. Includes:

- 00902-60003 3.5 mm (m) fixed load
- 00902-60004 3.5 mm (f) fixed load
- 85052-60006 3.5 mm (m) short
- 85052-60007 3.5 mm (f) short
- 85052-60008 3.5 mm (m) open
- 85052-60009 3.5 mm (f) open
- 85052-60032 3.5 mm (f) to 3.5 mm (f) adapter
- 85052-60033 3.5 mm (m) to 3.5 mm (m) adapter
- 85052-60034 3.5 mm (f) to 3.5 mm (m) adapter
- 85052-60035 3.5 mm short TRL line
- 85052-60036 3.5 mm long TRL line

85052D economy: DC to 26.5 GHz. Includes:

- 00902-60003 3.5 mm (m) fixed load
- 00902-60004 3.5 mm (f) fixed load
- 85052-60006 3.5 mm (m) short
- 85052-60007 3.5 mm (f) short
- 85052-60008 3.5 mm (m) open
- 85052-60009 3.5 mm (f) open
- 85052-60012 3.5 mm (f) to 3.5 mm (f) adapter
- 85052-60013 3.5 mm (f) to 3.5 mm (m) adapter
- 85052-60014 3.5 mm (m) to 3.5 mm (m) adapter

Electronic calibration kits

85093C RF ECal: 300 kHz to 9 GHz, 2-ports; Standard module includes:

- Option MOF with: 85093-60008 3.5 mm (f) to 3.5 mm (m) ECal module
- Option 00F module with: 85093-60010 3.5 mm (f) to 3.5 mm (f) ECal module
- Option 00M module with: 85093-60009 3.5 mm (m) to 3.5 mm (m) ECal module
- Option 00A adds:
- 85052-60012 3.5 mm (f) to 3.5 mm (f) adapter
- 85052-60014 3.5 mm (m) to 3.5 mm (m) adapter
- Option 150: Replaces standard storage container with a wooden box

85093C-xxx mixed-connector options:

Port A option			Port B option					
Type	(f)	(m)	Type	(f)	(m)	Type	(f)	(m)
3.5 mm	101	102	Type-N 50 ohm	203	204	7-16	205	206

N4431D Microwave ECal: DC to 13.5 GHz, 4-ports. Includes:

- Option 010 module with: N4431-60006 4 x 3.5 mm (f) ECal module

N4431D mixed connector options:

Connector type	Port A option	Port B option	Port C option	Port D option
3.5 mm -f-	101	201	301	401
3.5 mm -m-	102	202	302	402
Type-N 50 ohm -f-	103	203	303	403
Type-N 50 ohm -m-	104	204	304	404
7-16 -f- ^a	105	205	305	405
7-16 -m- ^a	106	206	306	406
4.3-10 -f- ^b	107	207	307	407
4.3-10 -m- ^b	108	208	308	408

- a. Limits ECal module high frequency to 7.5 GHz.
 b. Limits ECal module high frequency to 12 GHz.

N4432D Microwave ECal: DC/300 kHz to 18 GHz, 4-ports.

- Frequency options
 - Option 0DC DC to 18 GHz
 - Option 003 300 kHz to 18 GHz
- Connector options
 - Option 020 Type-N female connector on four ports on module

N4432D mixed-connector options:

Connector type	Port A option	Port B option	Port C option	Port D option
3.5 mm (f)	101	201	301	401
3.5 mm (m)	102	202	302	402
Type-N 50 ohm (f)	103	203	303	403
Type-N 50 ohm (m)	104	204	304	404

N4433D Microwave ECal: DC/300 kHz to 26.5 GHz, 4-ports.

- Frequency options
 - Option 0DC DC to 26.5 GHz
 - Option 003 300 kHz to 26.5 GHz
- Connector options
 - Option 010 3.5 mm female connector on four ports on module

N4433D mixed-connector options:

Connector type	Port A option	Port B option	Port C option	Port D option
3.5 mm (f)	101	201	301	401
3.5 mm (m)	102	202	302	402

N4691D¹ Microwave ECal: DC or 300 kHz to 26.5 GHz, 2-ports.

Includes:

- Option F0F: Both connectors are 3.5 mm female on module
- Option M0F: 1 female and 1 male 3.5 mm connector on module
- Option M0M: Both connectors are 3.5 mm male on module
- Option 0DC: DC to 26.5 GHz
- Option 003: 300 kHz to 26.5 GHz
- Option 00A adds:
 - 85052-60012 3.5 mm (f) to 3.5 mm (f) adapter
 - 85052-60014 3.5 mm (m) to 3.5 mm (m) adapter

Cables

- 85131C² single, semi-rigid: 3.5 mm (f) to PSC-3.5 mm (f), 81 cm, 32 inches
- 85131D² set, semi-rigid:
 - One 3.5 mm (f) to 3.5 mm (m), 53 cm, 21 inches, p/n 85131-60009
 - One 3.5 mm (f) to PSC-3.5 mm (f), 53 cm, 21 inches, p/n 85131-60010
- 85131E² single, flexible: 3.5 mm (f) to PSC-3.5 mm (f), 96.5 cm, 38 inches
- 85131F² set, flexible:
 - One 3.5 mm (f) to 3.5 mm (m), 62.2 cm, 24.5 inches, p/n 85131-60012
 - One 3.5 mm (f) to PSC-3.5 mm (f), 62.2 cm, 24.5 inches, p/n 85131-60013
- 85131H² single, flexible: 3.5 mm (f) to 3.5 mm (m), 62.2 cm, 24.5 inches
- 85134E² single, flexible: PSC-3.5 mm (f) to 2.4 mm (f), 96 cm, 38 inches
- 85134F² set, flexible:
 - One 2.4 mm (f) to PSC-3.5 mm (f), 53 cm, 21 inches, p/n 85134-60004
 - One 2.4 mm (f) to PSC-3.5 mm (m), 53 cm, 21 inches, p/n 85134-60003
- 85134H² single, flexible: 2.4 mm (f) to PSC-3.5 mm (m), 53 cm, 21 inches
- N4419AK20 single, flexible: 3.5 mm (m) to 3.5 mm (f), 91.4 cm, 36 inches
- Z5623A-K20 single, flexible: 3.5 mm (m) to 3.5 mm (m), 91.4 cm, 36 inches

Adapter sets

- 85130D 3.5 mm² to 3.5 mm

1. The PNA Series must have firmware revision A.12.85.00 or above for the operation with the N443xD/N469xD Series ECal.
2. Special rugged female connector specifically for connecting to the network analyzer test port, but does not mate with a standard male connector.

For devices with Type-N connectors

Mechanical calibration kits

85054B standard: DC to 18 GHz. Includes:

- 00909-60011 Type-N (m) fixed lowband load
- 00909-60012 Type-N (f) fixed lowband load
- 85054-60025 Type-N (m) short
- 85054-60026 Type-N (f) short
- 85054-60027 Type-N (m) open
- 85054-60028 Type-N (f) open
- 85054-60031 Type-N (f) to 7mm adapter
- 85054-60032 Type-N (m) to 7mm adapter
- 85054-60037 Type-N (f) to Type-N (f) adapter
- 85054-60038 Type-N (m) to Type-N (m) adapter
- 85054-80010 Type-N (f) sliding load
- 85054-80009 Type-N (m) sliding load
- 85054-60050 Type-N (f) connector gage
- 85054-60052 Type-N (f) gage master
- 85054-60051 Type-N (m) connector gage
- 85054-60053 Type-N (m) gage master

85054D economy: DC to 18 GHz. Includes:

- 85054-60025 Type-N (m) short
- 85054-60026 Type-N (f) short
- 85054-60027 Type-N (m) open
- 85054-60028 Type-N (f) open
- 85054-60031 Type-N (f) to 7mm adapter
- 85054-60032 Type-N (m) to 7mm adapter
- 85054-60037 Type-N (f) to Type-N (f) adapter
- 85054-60038 Type-N (m) to Type-N (m) adapter
- 85054-60046 Type-N (m) fixed load
- 85054-60047 Type-N (f) fixed load

Adapter sets

- 85130C 3.5 mm to Type-N

Electronic calibration kits

N4431D Microwave ECal: DC to 13.5 GHz, 4-ports. Includes:

- Frequency option (mandatory)
 - Option 0DC DC to 13.5 GHz
- Connector options
 - Option 010 3.5 mm female connector on four ports on module
 - Option 020 Type-N female connector on four ports on module

N4431D mixed connector options:

Connector type	Port A option	Port B option	Port C option	Port D option
3.5 mm -f-	101	201	301	401
3.5 mm -m-	102	202	302	402
Type-N 50 ohm -f-	103	203	303	403
Type-N 50 ohm -m-	104	204	304	404
7-16 -f- ^a	105	205	305	405
7-16 -m- ^a	106	206	306	406
4.3-10 -f- ^b	107	207	307	407
4.3-10 -m- ^b	108	208	308	408

- a. Limits ECal module high frequency to 7.5 GHz.
- b. Limits ECal module high frequency to 12 GHz.

N4432D Microwave ECal: DC/300 kHz to 18 GHz, 4-ports.

- Frequency options
 - Option 0DC DC to 18 GHz
 - Option 003 300 kHz to 18 GHz
- Connector options
 - Option 020 Type-N female connector on four ports on module

N4432D mixed-connector options:

Connector type	Port A option	Port B option	Port C option	Port D option
3.5 mm (f)	101	201	301	401
3.5 mm (m)	102	202	302	402
Type-N 50 ohm (f)	103	203	303	403
Type-N 50 ohm (m)	104	204	304	404

N4690D² Microwave ECal: DC or 300 kHz to 18 GHz, 2-ports.

Includes:

- Option F0F: Both connectors are Type-N 50 Ω female on module
- Option M0F: 1 female and 1 male Type-N 50 Ω connector on module
- Option M0M: Both connectors are Type-N 50 Ω male on module
- Option 0DC: DC to 18 GHz
- Option 003: 300 kHz to 18 GHz
- Option 00A adds:
 - 85054-60037 Type-N (f) to Type-N (f) adapter
 - 85054-60038 Type-N (m) to Type-N (m) adapter

Cables

Use the test port cables recommended for devices with 7 mm connectors, and 7 mm to Type-N adapters that are from the 85054B/D Type-N calibration kit (see 7 mm connector section).

1. Special rugged female connector specifically for connecting to the network analyzer test port, but does not mate with a standard male connector.
2. The PNA Series must have firmware revision A.12.85.00 or above for the operation with the N443xD/N469xD Series ECal.

For devices with 7 mm connectors

Mechanical calibration kits

85050B standard: DC to 18 GHz. Includes:

- 00909-60008 7 mm coax termination
- 85050-60006 7 mm fixed broadband load
- 85050-80007 7 mm short
- 85050-80010 7 mm open
- 85050-80011 7 mm sliding load

85050C precision TRL: DC to 18 GHz. Includes:

- 00909-60008 7 mm coax termination
- 85050-60003 7 mm to 7 mm airline
- 85050-60005 7 mm to 7 mm TRL adapter
- 85050-60006 7 mm fixed broadband load
- 85050-80008 7 mm short
- 85050-80009 7 mm short collet
- 85050-80010 7 mm open

85050D economy: DC to 18 GHz. Includes:

- 85050-60006 7 mm fixed broadband load
- 85050-80007 7 mm short
- 85050-80010 7 mm open

Electronic calibration kits

N4696D ¹ Microwave ECal: DC or 300 kHz to 18 GHz, 2-ports, 7 mm connectors. Includes:

- Option 0DC: DC to 18 GHz
- Option 003: 300 kHz to 18 GHz

Cables

- 85132E single, flexible: 3.5 mm (f) to 7 mm, 97.2 cm, 38.25 inches ²
- 85132F set, flexible: two 3.5 mm (f) to 7 mm cables, 62.9 cm each, 24.75 inches each ², p/n 85132-60004
- 85133F cable set (set, flexible, 2.4 mm, 53 cm each, 21 inches each)
- 85134F cable set (set, flexible, 2.4 mm (f) to 3.5 mm (f) and (m), 53 cm each, 21 inches each)
- 85135E single, flexible: 2.4 mm (f) to 7 mm, 96 cm, 38 inches
- 85135F set, flexible: two 2.4 mm (f) to 7 mm cables, 53 cm each, 21 inches each, p/n 85135-60002

Adapter sets

- 85130E 2.4 mm to 7 mm
- R281A adapter (2.4 mm (f) to WR-28 waveguide adapter)
- R281B adapter (2.4 mm (m) to WR-28 waveguide adapter)
- Q281A adapter (2.4 mm (f) to WR-22 waveguide adapter)
- Q281B adapter (2.4 mm (m) to WR-22 waveguide adapter)

For devices with waveguide

Mechanical calibration kits

X Band

X11644A standard, WR-90: 8.2 to 12.4 GHz. Includes:

- 00896-60008 X-band standard section
- 00910-60003 X-band termination
- 11644-20018 X-band short
- 11644-20021 X-band shim
- X281C adapter (included in calibration kit): WR-90 to 7 mm

P Band

P11644A standard, WR-62: 12.4 to 18 GHz. Includes:

- 00896-60007 P-band standard section
- 00910-60002 P-band termination
- 11644-20017 P-band short
- 11644-20020 P-band shim
- P281C adapter (included in calibration kit): WR-62 to 7 mm

K Band

K11644A standard, WR-42: 18 to 26.5 GHz. Includes:

- 00896-60006 K-band standard section
- 00910-60001 K-band termination
- 11644-20016 K-band short
- 11644-20019 K-band shim
- K281C adapter (included in calibration kit): WR-42 to 3.5 mm (f) Option 012 WR-42 to 3.5 mm (m)

R Band

R11644A standard, WR-28: 26.5 to 40 GHz. Includes:

- 00914-20028 R-band termination
- 11644-20005 R-band short
- 11644-20003 R-band shim
- 11644-60001 R-band 10 cm straight waveguide
- 11644-60016 R-band 5 cm straight waveguide

1. The PNA Series must have firmware revision A.12.85.00 or above for the operation with the N469xD Series ECal.
2. Special rugged female connector specifically for connecting to the network analyzer test port, but does not mate with a standard male connector.

Q Band

Q11644A standard, WR-22: 33 to 50 GHz. Includes:

- 11644-60005 Q-band termination
- 11644-20004 Q-band short
- 11644-20001 Q-band shim
- 11644-60002 Q-band 10 cm straight waveguide
- 11644-60017 Q-band 5 cm straight waveguide

U Band

U11644A standard, WR-19: 40 to 60 GHz. Includes:

- 11644-60006 U-band termination
- 11644-20004 U-band short
- 11644-20002 U-band shim
- 11644-60003 U-band 10 cm straight waveguide
- 11644-60018 U-band 5 cm straight waveguide

V Band

V11644A standard, WR-15: 50 to 75 GHz. Includes:

- 11644-60025 V-band termination
- 11644-20015 V/W-band short
- 11644-20013 V-band shim
- 11644-60012 V-band standard section

W Band

W11644A standard, WR-10: 75 to 110 GHz. Includes:

- 11643-60026 W-band termination
- 11644-20015 V/W-band short
- 11644-20014 W-band shim
- 11644-60013 W-band standard section

Verification kits

All Keysight verification kits include:

- Precision Z_0 airline or match thru
- Mismatched airline or mismatch thru
- Fixed attenuators (except 85059V)
- Traceable measured data and uncertainties

85051B 45 MHz to 18 GHz 7 mm kit

Includes attenuators, airline and mismatch airline with data on a USB drive for use in confirming calibrated system performance, traceable to national standards. Test procedure is provided in the service manual.

85053B 300 kHz to 26.5 GHz 3.5 mm kit

Includes attenuators, airline and mismatch airline with data on a USB drive for use in confirming calibrated system performance, traceable to national standards. Test procedure is provided in the service manual.

85055A 300 kHz to 18 GHz Type-N kit

Includes attenuators, airline and mismatch airline with data on a USB drive for use in confirming calibrated system performance, traceable to national standards. Test procedure is provided in the service manual.

85057B 45 MHz to 50 GHz 2.4 mm kit

Includes attenuators, airline and mismatch airline with data on a USB drive for use in confirming calibrated system performance, traceable to national standards. Test procedure is provided in the service manual.

85058V 45 MHz to 67 GHz 1.85 mm kit

Includes attenuators, match thru and mismatch thru with data on a USB drive for use in confirming calibrated system performance, traceable to national standards. Test procedure is provided in the service manual.

85059V 10 MHz to 110 GHz 1.0 mm kit

Includes a matched airline (85059-60048) and a mismatch airline (85059-60047), with data on a USB drive for use in confirming calibrated system performance traceable to national standards. Test procedure is provided in the service manual.

Accessories

Solid black series name indicates the feature is available on that series, while gray series name with strikethrough indicates the feature is not available on that series. For example:

PNA:	Available on PNA Series
PNA :	Not available on PNA Series

Rack mount kit without handles (Option 1CM)

~~PNA-X~~ PNA PNA-L

Adds a rack mount flange kit 1CM042A and a rail kit (E3663AC) for use without handles.

Rack mount kit with handles (Option 1CP)

~~PNA-X~~ PNA PNA-L

Adds a rack mount flange kit with handles (5063-1555) and a rail kit (E3663AC) for use with handles.

Pulse I/O adapter (N1966A)

PNA-X PNA ~~PNA-L~~

This adapter enables coaxial connections between the Pulse I/O D-sub connector on the rear panel of the analyzer and the coaxial inputs and outputs of external pulse generators and external pulse modulators. Coaxial connectors are SMB-male. The PULSE IN connectors are for controlling the analyzer's internal IF gates, which are enabled with S93026B and used with narrowband detection. The PULSE OUT connectors are from the four internal pulse generators, which are enabled with S93025/26B. The PULSE SYNC IN connector is used to synchronize the internal pulse generators with an external timing pulse. The RF PULSE MOD IN connector controls the internal pulse modulator(s) which are enabled with Options 021 and 022.



Pulse I/O adapter (N1966A) simplifies connections

Comb Generators

U9391C 10 MHz to 26.5 GHz

U9391F 10 MHz to 50 GHz

U9391G 10 MHz to 67 GHz

PNA-X PNA ~~PNA-L~~

The U9391C/F/G provides precision phase calibration, traceable to the National Institute of Standards and Technology (NIST) standard. It is used for nonlinear measurements with the PNA-X nonlinear vector network analyzer (NVNA). NVNA requires two comb generators, one is connected during measurements and another is used only during calibration. A comb generator is also used to characterize the VNA receivers for delay measurements of frequency converters using PNA-X or PNA instruments and the SMC+Phase measurement class (part of S93083B). Requires a separate DC power supply for operation.



CalPod calibration refresh modules (8553xB/4xA)

PNA-X PNA ~~PNA-L~~

CalPod calibration refresh modules allow in-situ calibration refreshes to be performed at the push of a button without removing the DUT or re-connecting calibration standards. CalPods are designed for any measurement situation where it is desirable to ensure that a valid calibration is present before recording measurement data. For example, they are useful for removing environmental effects such as cable movement and thermal-based changes of cables, connectors, and adapters, as well as connector and switch-matrix repeatability errors. The modules are especially useful in temperature, or thermal-vacuum chamber testing. CalPod modules are equipped with 2.92 mm connectors.

- 85530B 20 GHz ambient-temperature CalPod
- 85531B 20 GHz temperature-compensated CalPod
- 85532B 20 GHz thermal-vacuum compatible CalPod
- 85540B 40 GHz ambient-temperature CalPod
- 85541B 40 GHz temperature-compensated CalPod
- 85542B 40 GHz thermal-vacuum compatible CalPod
- 85523B CalPod controller (provides control for up to 4 CalPods)
- 85556A CalPod drive-cable splitter (allows control for up to 12 CalPods)
- 85554A CalPod drive cable extension (10-meter cascable extension cable)

Spare drive ¹

- N5242-60134 Windows 7 spare drive with mounting cradle for all N522x/3x/4xB models with 2.2 GHz CPU (version 7)
- N5242-60135 Windows 10 spare drive with mounting cradle for all N522x/3x/4xB models with 2.2 GHz CPU (version 7)

For information about spare drives for older PNA models, please refer to the configuration guide 5990-7745EN.

Probe

- 85024A high-frequency probe; provides high-impedance in-circuit test capability from 300 kHz to 3 GHz.

1. All spare drives use solid-state storage. For more information, refer to na.support.keysight.com/pna/hdnumbers.html.

Power meters and sensors ¹

- Recommended for self support, adjustments and performance tests to verify proper instrument operation.
- U848x Series USB thermocouple power sensors
- U2020 X-Series USB peak and average power sensors
- U2000 Series USB power sensors
- U2040/50/60 X-Series USB and LAN power sensors
- P Series power meters (N1911A and N1912A) and all supported sensors
- EPM Series power meters (N1913A and N1914A) and all supported sensors
- EPM-P Series power meters (E4416A and E4417A) and all supported sensors

Amplifiers

- 83006A power amplifier, 10 MHz to 26.5 GHz, 20 dB gain, power out: +18 dBm to 10 GHz or +16 dBm to 20 GHz or +14 dBm to 26.5 GHz
- 83017A power amplifier, 50 MHz to 26.5 GHz, 25 dB gain, power out: +20 dBm to 20 GHz, or +15 dBm to 26.5 GHz
- 83018A power amplifier, 2 to 26.5 GHz, 27 dB gain to 20 GHz or 23 dB to 26.5 GHz, power out: +24 dBm to 20 GHz or +21 dBm to 26.5 GHz
- 83020A power amplifier, 2 to 26.5 GHz, 30 dB gain to 20 GHz or 27 dB to 26.5 GHz, power out: +30 dBm to 20 GHz or +26 dBm to 26.5 GHz
- 83050A power amplifier, 2 to 50 GHz, 23 dB gain, power out: +20 dBm to 40 GHz or +17 dBm to 50 GHz
- 83051A power amplifier, 45 MHz to 50 GHz, 23 dB gain power out: +12 dBm to 45 GHz or +10 dBm to 50 GHz

Couplers

- 87300B coaxial coupler, 1 to 20 GHz, SMA (f), 10 dB coupling
- 87300C coaxial coupler, 1 to 26.5 GHz, 3.5 mm (f), 10 dB coupling
- 87301B coaxial coupler, 10 to 46 GHz, 2.92 mm (f), 10 dB coupling
- 87301D coaxial coupler, 1 to 40 GHz, 2.4 mm (f) or optional 2.92 mm (f), 13 dB coupling
- 87301E coaxial coupler, 2 to 50 GHz, 2.4 mm (f), 10 dB coupling
- 87310B 90° coaxial coupler, 1 to 18 GHz, SMA (f), 3 dB coupling

Equipment rack accessories

- E3663AC Rail kit (included with Option 1CM and 1CP)
- 1CM042A Rack mount flange kit, for use without handles (included with Option 1CM)
- 5063-1555 Rack mount flange kit with handles (included with Option 1CP) ¹

Monitors

Any VGA-compatible monitor can be connected directly to the rear panel. Monitors with other video interfaces (for example, HDMI or DisplayPort) require USB-based video adapters (must be supplied by the user). Touch-screen monitors are supported.

Interface cables

Choose the appropriate cables to connect each peripheral to the network analyzer.

- 10833A GPIB cable, 1.0 m (3.3 ft)
- 10833B GPIB cable, 2.0 m (6.6 ft)
- 10833D GPIB cable, 0.5 m (1.6 ft)
- 82357B GPIB to USB interface

1. For the latest guide to power meters and power sensors, refer to the Keysight web site: www.keysight.com/find/powermeters.

Active Device Characterization/Test Solution Bundle Models

There are four bundle models available for purchase convenience with a bundle discount. The bundle models: N5244BM, N5245BM, N5247BM, N5245BP, contain a PNA-X, some software applications and accessories for 43.5 GHz, 50 GHz, and 67 GHz active device characterization and 50 GHz frequency converter test for 5G and more applications.

See the included items in the tables below. The included items are predefined and can't be changed, reduced or added. The functions and the performance are the same as the individual purchase of the PNA-X and the accessories. For more information about these bundle products, please contact your Keysight sales representative.

N5247BM millimeterWave active device characterization

Item	Description	Quantity
N5247B	10 MHz to 67 GHz PNA-X network analyzer	1
N5247B-423	4-port, configurable test set, second source, source attenuators, receiver attenuators, bias tees, combiner, mechanical switches	1
N5247B-020	Add IF inputs	1
N5247B-021	Add pulse modulator to internal first source	1
N5247B-022	Add pulse modulator to internal second source	1
N5247B-029	Add noise receiver to 50 GHz	1
R-55A-001-1	KeysightCare Assured first year support	1
S93007B	Automatic fixture removal	1
R-A5A-001-A	Node-locked perpetual license	1
R-A6A-001-L	KeysightCare software support subscription, node-locked - 12 months	1
S93025B	Basic pulsed-RF measurements	1
R-A5A-001-A	Node-locked perpetual license	1
R-A6A-001-L	KeysightCare software support subscription, node-locked - 12 months	1
N1966A	Pulse I/O adapter	1
S93029B	Noise figure measurements with vector correction	1
R-A5A-001-A	Node-locked perpetual license	1
R-A6A-001-L	KeysightCare software support subscription, node-locked - 12 months	1
S93083B	Vector and scalar mixer/converter measurements	1
R-A5A-001-A	Node-locked perpetual license	1
R-A6A-001-L	KeysightCare software support subscription, node-locked - 12 months	1
S93084B	Embedded-LO capability	1
R-A5A-001-A	Node-locked perpetual license	1
R-A6A-001-L	KeysightCare software support subscription, node-locked - 12 months	1
S93086B	Gain-compression measurements	1

Item	Description	Quantity
R-A5A-001-A	Node-locked perpetual license	1
R-A6A-001-L	KeysightCare software support subscription, node-locked - 12 months	1
S93087B	Intermodulation distortion measurements	1
R-A5A-001-A	Node-locked perpetual license	1
R-A6A-001-L	KeysightCare software support subscription, node-locked - 12 months	1
S93089B	Differential and I/Q device measurements	1
R-A5A-001-A	Node-locked perpetual license	1
R-A6A-001-L	KeysightCare software support subscription, node-locked - 12 months	1
N4694D	67 GHz 2-port 1.85 mm ECal module	2
N4694D-100	10 MHz to 67 GHz	2
N4694D-M0F	One male connector and one female connector	2
N4694D-00A	Add 1.85mm adapters	1
U8488A	Power Sensor; USB average thermocouple, 10 MHz to 67 GHz	1
U8488A-100	Connector 2.4MM, (DC Block) 10 MHz to 67 GHz	1
U9391G	Comb Generator, 10 MHz to 67 GHz	1
U9391G-FFF	Two 3.5 mm Connectors are Female and Output Connector is 1.85mm Female On Module	1
N4421B-K67	Test port cables, 3ft, 1.85mm (m-f) quantity 1	4

N5245BM 5G active device characterization

Item	Description	Quantity
N5245B	10 MHz to 50 GHz PNA-X network analyzer	1
N5245B-423	4-port, configurable test set, second source, source attenuators, receiver attenuators, bias tees, combiner, mechanical switches	1
N5245B-020	Add IF inputs	1
N5245B-021	Add pulse modulator to internal first source	1
N5245B-022	Add pulse modulator to internal second source	1
N5245B-029	Add noise receiver to 50 GHz	1
R-55A-001-1	KeysightCare Assured first year support	1
S93007B	Automatic fixture removal	1
R-A5A-001-A	Node-locked perpetual license	1
R-A6A-001-L	KeysightCare software support subscription, node-locked - 12 months	1
S93025B	Basic pulsed-RF measurements	1
R-A5A-001-A	Node-locked perpetual license	1
R-A6A-001-L	KeysightCare software support subscription, node-locked - 12 months	1
N1966A	Pulse I/O adapter	1
S93029B	Noise figure measurements with vector correction	1

Item	Description	Quantity
R-A5A-001-A	Node-locked perpetual license	1
R-A6A-001-L	KeysightCare software support subscription, node-locked - 12 months	1
S93083B	Vector and scalar mixer/converter measurements	1
R-A5A-001-A	Node-locked perpetual license	1
R-A6A-001-L	KeysightCare software support subscription, node-locked - 12 months	1
S93084B	Embedded-LO capability	1
R-A5A-001-A	Node-locked perpetual license	1
R-A6A-001-L	KeysightCare software support subscription, node-locked - 12 months	1
S93086B	Gain-compression measurements	1
R-A5A-001-A	Node-locked perpetual license	1
R-A6A-001-L	KeysightCare software support subscription, node-locked - 12 months	1
S93087B	Intermodulation distortion measurements	1
R-A5A-001-A	Node-locked perpetual license	1
R-A6A-001-L	KeysightCare software support subscription, node-locked - 12 months	1
S93089B	Differential and I/Q device measurements	1
R-A5A-001-A	Node-locked perpetual license	1
R-A6A-001-L	KeysightCare software support subscription, node-locked - 12 months	1
N4693D	50 GHz 2-port 2.4 mm ECal module	1
N4693D-100	10 MHz to 50 GHz	1
N4693D-M0F	One male connector and one female connector	1
N4693D-00A	Add 2.4mm adapters	1
U8487A	Power Sensor; USB average thermocouple, 10 MHz to 50 GHz	1
U8487A-100	Connector 2.4MM, (DC Block) 10 MHz to 50 GHz	1
U9391F	50 GHz comb generator	1
U9391F-FFF	Two 3.5 mm Connectors are Female and Output Connector is 2.4 mm Female On Module	1
N9910X-714	Rugged phase-stable cable, 2.4 mm (f) to 2.4 mm (m), 50 GHz, 3.28 ft or 1 m	4

N5245BP frequency converter test up to 50 GHz

Item	Description	Quantity
N5245B	10 MHz to 50 GHz PNA-X network analyzer	1
N5245B-423	4-port, configurable test set, second source, source attenuators, receiver attenuators, bias tees, combiner, mechanical switches	1
R-55A-001-1	KeysightCare Assured first year support	1
S93007B	Automatic fixture removal	1
R-A5A-001-A	Node-locked perpetual license	1
R-A6A-001-L	KeysightCare software support subscription, node-locked - 12 months	1
S93083B	Vector and scalar mixer/converter measurements	1
R-A5A-001-A	Node-locked perpetual license	1
R-A6A-001-L	KeysightCare software support subscription, node-locked - 12 months	1
S93084B	Embedded-LO capability	1
R-A5A-001-A	Node-locked perpetual license	1
R-A6A-001-L	KeysightCare software support subscription, node-locked - 12 months	1
N4693D	50 GHz 2-port 2.4 mm ECal module	1
N4693D-100	10 MHz to 50 GHz	1
N4693D-F0F	Both connectors female	1
U8487A	Power Sensor; USB average thermocouple, 10 MHz to 50 GHz	1
U8487A-100	Connector 2.4MM, (DC Block) 10 MHz to 50 GHz	1
N9910X-714	Rugged phase-stable cable, 2.4 mm (f) to 2.4 mm (m), 50 GHz, 3.28 ft or 1 m	4

N5245BQ Frequency converter characterization with modulated signal

Item	Description	Quantity
N5245B	10 MHz to 50 GHz PNA-X network analyzer	1
N5245B-423	4-port, configurable test set, second source, source attenuators, receiver attenuators, bias tees, combiner, mechanical switches	1
N5245B-029	Add noise receiver to 50 GHz	1
N5245B-XSB	Add 3rd source	1
R-55A-001-1	KeysightCare Assured first year support	1
S93007B	Automatic fixture removal	1
R-A5A-001-A	Node-locked perpetual license	1
R-A6A-001-L	KeysightCare software support subscription, node-locked - 12 months	1
S930705B	Modulation distortion up to 50 GHz	1
R-A5A-001-A	Node-locked perpetual license	1
R-A6A-001-L	KeysightCare software support subscription, node-locked - 12 months	1
S93029B	Noise figure measurements with vector correction	1
R-A5A-001-A	Node-locked perpetual license	1
R-A6A-001-L	KeysightCare software support subscription, node-locked - 12 months	1

N5245BQ Frequency converter characterization with modulated signal (continued)

Item	Description	Quantity
S93083B	Vector and scalar mixer/converter measurements	1
R-A5A-001-A	Node-locked perpetual license	1
R-A6A-001-L	KeysightCare software support subscription, node-locked - 12 months	1
S93084B	Embedded-LO capability	1
R-A5A-001-A	Node-locked perpetual license	1
R-A6A-001-L	KeysightCare software support subscription, node-locked - 12 months	1
S93086B	Gain-compression measurements	1
R-A5A-001-A	Node-locked perpetual license	1
R-A6A-001-L	KeysightCare software support subscription, node-locked - 12 months	1
S93087B	Intermodulation distortion measurements	1
R-A5A-001-A	Node-locked perpetual license	1
R-A6A-001-L	KeysightCare software support subscription, node-locked - 12 months	1
S93089B	Differential and I/Q device measurements	1
R-A5A-001-A	Node-locked perpetual license	1
R-A6A-001-L	KeysightCare software support subscription, node-locked - 12 months	1
N4693D	50 GHz 2-port 2.4 mm ECal module	1
N4693D-100	10 MHz to 50 GHz	1
N4693D-MOF	One male connector and one female connector	1
N4693D-00A	Add 2.4mm adapters	1
U8487A	Power Sensor; USB average thermocouple, 10MHz-50GHz	1
U8487A-100	Connector 2.4MM, (DC Block) 10 MHz - 50 GHz	1
U9391F	50 GHz comb generator	1
U9391F-FFF	Two 3.5 mm Connectors are Female and Output Connector is 2.4mm Female On Module	1
N9910X-714	Rugged phase-stable cable, 2.4 mm (f) to 2.4 mm (m), 50 GHz, 3.28 ft or 1 m	4

N5245BV Amplifier characterization with modulated signal

Item	Description	Quantity
N5245B	10 MHz to 50 GHz PNA-X network analyzer	1
N5245B-423	4-port, configurable test set, second source, source attenuators, receiver attenuators, bias tees, combiner, mechanical switches	1
N5245B-029	Add noise receiver to 50 GHz	1
R-55A-001-1	KeysightCare Assured first year support	1
S93007B	Automatic fixture removal	1
R-A5A-001-A	Node-locked perpetual license	1
R-A6A-001-L	KeysightCare software support subscription, node-locked - 12 months	1
S930705B	Modulation distortion up to 50 GHz	1
R-A5A-001-A	Node-locked perpetual license	1
R-A6A-001-L	KeysightCare software support subscription, node-locked - 12 months	1
S93029B	Noise figure measurements with vector correction	1
R-A5A-001-A	Node-locked perpetual license	1
R-A6A-001-L	KeysightCare software support subscription, node-locked - 12 months	1
S93086B	Gain-compression measurements	1
R-A5A-001-A	Node-locked perpetual license	1
R-A6A-001-L	KeysightCare software support subscription, node-locked - 12 months	1
S93087B	Intermodulation distortion measurements	1
R-A5A-001-A	Node-locked perpetual license	1
R-A6A-001-L	KeysightCare software support subscription, node-locked - 12 months	1
S93089B	Differential and I/Q device measurements	1
R-A5A-001-A	Node-locked perpetual license	1
R-A6A-001-L	KeysightCare software support subscription, node-locked - 12 months	1
N4693D	50 GHz 2-port 2.4 mm ECal module	1
N4693D-100	10 MHz to 50 GHz	1
N4693D-MOF	One male connector and one female connector	1
N4693D-00A	Add 2.4mm adapters	1
U8487A	Power Sensor; USB average thermocouple, 10MHz-50GHz	1
U8487A-100	Connector 2.4MM, (DC Block) 10 MHz - 50 GHz	1
U9391F	50 GHz comb generator	1
U9391F-FFF	Two 3.5 mm Connectors are Female and Output Connector is 2.4mm Female On Module	1
N9910X-714	Rugged phase-stable cable, 2.4 mm (f) to 2.4 mm (m), 50 GHz, 3.28 ft or 1 m	4

N5244BM 5G active device characterization

Item	Description	Quantity
N5244B	10 MHz to 43.5 GHz PNA-X network analyzer	1
N5244B-423	4-port, configurable test set, second source, source attenuators, receiver attenuators, bias tees, combiner, mechanical switches	1
N5244B-020	Add IF inputs	1
N5244B-021	Add pulse modulator to internal first source	1
N5244B-022	Add pulse modulator to internal second source	1
N5244B-029	Add noise receiver to 50 GHz	1
R-55A-001-1	KeysightCare Assured first year support	1
S93007B	Automatic fixture removal	1
R-A5A-001-A	Node-locked perpetual license	1
R-A6A-001-L	KeysightCare software support subscription, node-locked - 12 months	1
S93025B	Basic pulsed-RF measurements	1
R-A5A-001-A	Node-locked perpetual license	1
R-A6A-001-L	KeysightCare software support subscription, node-locked - 12 months	1
N1966A	Pulse I/O adapter	1
S93029B	Noise figure measurements with vector correction	1
R-A5A-001-A	Node-locked perpetual license	1
R-A6A-001-L	KeysightCare software support subscription, node-locked - 12 months	1
S93083B	Vector and scalar mixer/converter measurements	1
R-A5A-001-A	Node-locked perpetual license	1
R-A6A-001-L	KeysightCare software support subscription, node-locked - 12 months	1
S93084B	Embedded-LO capability	1
R-A5A-001-A	Node-locked perpetual license	1
R-A6A-001-L	KeysightCare software support subscription, node-locked - 12 months	1
S93086B	Gain-compression measurements	1
R-A5A-001-A	Node-locked perpetual license	1
R-A6A-001-L	KeysightCare software support subscription, node-locked - 12 months	1
S93087B	Intermodulation distortion measurements	1
R-A5A-001-A	Node-locked perpetual license	1
R-A6A-001-L	KeysightCare software support subscription, node-locked - 12 months	1
S93089B	Differential and I/Q device measurements	1
R-A5A-001-A	Node-locked perpetual license	1
R-A6A-001-L	KeysightCare software support subscription, node-locked - 12 months	1
N4693D	50 GHz 2-port 2.4 mm ECal module	1
N4693D-100	10 MHz to 50 GHz	1
N4693D-MOF	One male connector and one female connector	1
N4693D-00A	Add 2.4mm adapters	1
U8487A	Power Sensor; USB average thermocouple, 10 MHz to 50 GHz	1

Item	Description	Quantity
U8487A-100	Connector 2.4 MM, (DC Block) 10 MHz to 50 GHz	1
U9391F	50 GHz comb generator	1
U9391F-FFF	Two 3.5 mm Connectors are Female and Output Connector is 2.4 mm Female On Module	1
N9910X-714	Rugged phase-stable cable, 2.4 mm (f) to 2.4 mm (m), 50 GHz, 3.28 ft or 1 m	4

N5222BT Signal integrity evaluation up to 26.5 GHz

Item	Description	Quantity
N5222B	900 Hz to 26.5 GHz PNA network analyzer	1
N5222B-405	4-port with second source, configurable test set, reference mixer switch, bias tees, low frequency extension	1
R-55A-001-1	KeysightCare Assured first year support	1
S93007B	Automatic fixture removal	1
R-A5A-001-A	Node-locked perpetual license	1
R-A6A-001-L	KeysightCare software support subscription, node-locked - 12 months	1
S93011B	Enhanced Time Domain Analysis with TDR	1
R-A5A-001-A	Enhanced time domain analysis with TDR, node-locked perpetual license	1
R-A6A-001-L	KeysightCare software support subscription, node-locked - 12 months	1
N19301B	PLTS Base Analysis	1
E8900-D10	USB read-only licensing dongle - FLEX10	1
R-A5G-005-E	USB portable perpetual license	1
R-A6G-005-L	KeysightCare software support subscription, USB portable - 12 months	1
N19303B	PLTS Measurement and Calibration	1
R-A5G-005-E	USB portable perpetual license	1
R-A6G-005-L	KeysightCare software support subscription, USB portable - 12 months	1
N19305B	PLTS Advanced Calibration	1
R-A5G-005-E	USB portable perpetual license	1
R-A6G-005-L	KeysightCare software support subscription, USB portable - 12 months	1
N19307B	PLTS N-Port Measurement and Analysis	1
R-A5G-005-E	USB portable perpetual license	1
R-A6G-005-L	KeysightCare software support subscription, USB portable - 12 months	1
N4433D	26.5 GHz 4-port 3.5 mm ECal module	1
N4433D-010	Four 3.5 mm female connectors on module	1
N4433D-0DC	DC to 26.5 GHz	1
N9910X-708	Rugged phase-stable cable, 3.5 mm(m) to 3.5 mm (f), 26.5 GHz, 3.28 ft or 1 m	4

N5225BT Signal integrity evaluation up to 50 GHz

Item	Description	Quantity
N5225B	10 MHz to 50 GHz PNA network analyzer	1
N5225B-417	4-port with second source, configurable test set, reference mixer switch, source and receiver attenuators	1
R-55A-001-1	KeysightCare Assured first year support	1
S93007B	Automatic fixture removal	1
R-A5A-001-A	Node-locked perpetual license	1
R-A6A-001-L	KeysightCare software support subscription, node-locked - 12 months	1
S93011B	Enhanced Time Domain Analysis with TDR	1
R-A5A-001-A	Enhanced time domain analysis with TDR, node-locked perpetual license	1
R-A6A-001-L	KeysightCare software support subscription, node-locked - 12 months	1
N19301B	PLTS Base Analysis	1
E8900-D10	USB read-only licensing dongle - FLEX10	1
R-A5G-005-E	USB portable perpetual license	1
R-A6G-005-L	KeysightCare software support subscription, USB portable - 12 months	1
N19303B	PLTS Measurement and Calibration	1
R-A5G-005-E	USB portable perpetual license	1
R-A6G-005-L	KeysightCare software support subscription, USB portable - 12 months	1
N19305B	PLTS Advanced Calibration	1
R-A5G-005-E	USB portable perpetual license	1
R-A6G-005-L	KeysightCare software support subscription, USB portable - 12 months	1
N19307B	PLTS N-Port Measurement and Analysis	1
R-A5G-005-E	USB portable perpetual license	1
R-A6G-005-L	KeysightCare software support subscription, USB portable - 12 months	1
N4693D	50 GHz 2-port 2.4 mm ECal module	1
N4693D-0DC	DC to 50 GHz	1
N4693D-F0F	Both connectors female	1
N9910X-714	Rugged phase-stable cable, 2.4 mm (f) to 2.4 mm (m), 50 GHz, 3.28 ft or 1 m	4

PNA Family Network Analyzer Upgrade Kits

Frequency, test ports, test set and power configurations

Upgrade kits are available to add options after initial purchase. To upgrade the PNA-X/PNA/PNA-L, order the corresponding item number. The model and serial numbers of the instrument to be retrofitted are required as part of the order. To add application software, order the appropriate standalone model numbers shown in the tables on pages 7 thru 9.

Description	Required Option	For PNA-X Series	For PNA Series	For PNA-L Series	User installable
Frequency upgrade ¹					
Extend analyzer's frequency range to 13.5 GHz	N5239/49B	N5249BU-613	N/A	N5239BU-613	No
Extend analyzer's frequency range to 20 GHz	N5231/39B	N/A	N/A	N5231/39BU-620	No
Extend analyzer's frequency range to 26.5 GHz	N5221/41/49B	N5241/49BU-626	N5221BU-626	N/A	No
Extend analyzer's frequency range to 50 GHz	N5224/34/44B	N5244BU-650	N5224BU-650	N5234BU-650	No
Direct Digital Synthesizer (DDS) signal source upgrade					
Single source	N522xB-2xx, N524xB-20x/21x	N524xBU-2S7	N522xBU-2S7	N/A	No
Dual source	N522xB-4xx, N524xB-22x/4xx	N524xBU-4S7	N522xBU-4S7	N/A	No
Add enhanced low phase noise ³	N/A	N524xBU-UNY	N522xBU-UNY	N/A	No
Add 3rd source ³	N524xB-422/423	N524xBU-XSB	N/A	N/A	No
Test ports					
Expand 2-ports, single source without configurable test set to 4-ports	N522xB-200	N/A	N522xBU-600/660 ³	N/A	No
Expand 2-ports, single source with configurable test set to 4-ports	N522x/4xB-201	N524xBU-601/661 ³	N522xBU-601/661 ³	N/A	No
Expand 2-ports, single source with configurable test set and low-frequency extension to 4-ports	N522xB-205	N/A	N522xBU-605/665 ³	N/A	No
Expand 2-ports, single source with configurable test set and extended power range to 4-ports	N522x/4xB-217	N524xBU-617/677 ³	N522xBU-617/677 ³	N/A	No
Expand 2-ports, single source with configurable test set, extended power range, and bias-tees to 4-ports	N522x/4xB-219	N524xBU-619/679 ³	N522xBU-619/679 ³	N/A	No
Expand 2-ports, single source with configurable test set, extended power range, and bias-tees to 4-ports	N522xB-220	N/A	N522xBU-620/680 ³	N/A	No
Expand 2-ports, internal second source with configurable test set, extended power range, combiner, and mechanical switches to 4-ports	N524xB-222	N524xBU-622	N/A	N/A	No
Expand 2-ports, internal second source with configurable test set, extended power range, bias-tees, combiner, and mechanical switches to 4-ports	N524xB-224	N524xBU-623	N/A	N/A	No

1. Frequency upgrade options from 8.5/13.5/20/26.5 GHz to 43.5/50 GHz and 43.5/50 GHz to 67 GHz are not available. Trade-in is recommended.

2. Not available on N5227/47B.

3. when the DDS source is already installed

PNA Family Network Analyzer Upgrade Kits (Continued)

Description	Required Option	For PNA-X Series	For PNA Series	For PNA-L Series	User installable
Test set and power configuration					
Add configurable test set, 2-ports	N522xB-200	N/A	N522xBU-201	N/A	No
Add configurable test set and source attenuators, 2-ports	N523xB-200	N/A	N/A	N523xBU-216	No
Add low frequency extension, 2-ports	N522xB/41/42B-201, or N522xB-217, 219	N5241/42BU-205	N522xBU-205 (for 201), N522xBU-220 (for 217 or 219)	N/A	No
Add extended power range, 2-ports ²	N522x/4xB-201	N524xBU-217	N522xBU-217	N/A	No
Add bias-tees, 2-ports ²	N522x/4xB-217 or N524xB-222	N524xBU-219	N522xBU-219	N/A	No
Add extended power range and bias tees, 2-ports	N5227/47B-201	N5247BU-219	N5227BU-219	N/A	No
Add internal 2nd source, combiner and mechanical switches, 2-ports	N524xB-217/219	N524xBU-224/284 ³	N/A	N/A	No
Add configurable test set, 4-ports	N522xB-400	N/A	N522xBU-401	N/A	No
Add configurable test set and source attenuators, 4-ports	N523xB-400	N/A	N/A	N523xBU-416	No
Add extended power range, 4-ports ¹	N522x/4xB-401	N524xBU-417	N522xBU-417	N/A	No
Add bias-tees, 4-ports ¹	N522x/4xB-417 or N524xB-422	N524xBU-419	N522xBU-419	N/A	No
Add extended power range and bias tees, 4-ports	N5227/47B-401	N5247BU-419	N5227BU-419	N/A	No
Add internal combiner and mechanical switches, 4-ports	N524xB-417/419	N524xBU-423	N/A	N/A	No
Add low frequency extension, 4-ports	N522xB-401, 417, 419, or N524xB-422, 423	N524xBU-425	N522xBU-405 (for 401), N522xBU-420 (for 417 or 419)	N/A	No
Add low-noise receiver, 2-ports	N524xB-21x, 22x	N524xBU-229	N/A	N/A	No
Add low-noise receiver, 4-ports	N524xB-41x, 42x	N524xBU-429	N/A	N/A	No
Pulse, antenna, mm-wave					
Add pulse modulator to internal 1st source		N524xBU-021	N522xBU-021	N/A	Yes
Add pulse modulator to internal 2nd source	Requires one of Options 22x, 40x, 41x, or 42x	N524xBU-022	N522xBU-022	N/A	Yes
Add IF inputs		N524xBU-020	N522xBU-020	N/A	Yes
A to B model upgrades					
The A to B model upgrade kit includes a new front-panel assembly with 12.1" multi-touch display, a new solid-state hard drive, and a new instrument cover and handles with Keysight's dark-gray color scheme ²		N524xAU-690	N522xAU-690	N523xAU-690	No

1. Not available on N5227/47B.

2. May also require update of CPU, SPAM, and synthesizer assemblies, supplied in separate upgrade kits. For more information, visit na.support.keysight.com/pna

3. When the DDS source is already installed

PNA Family Network Analyzer Upgrade Kits (Continued)

Upgrade paths

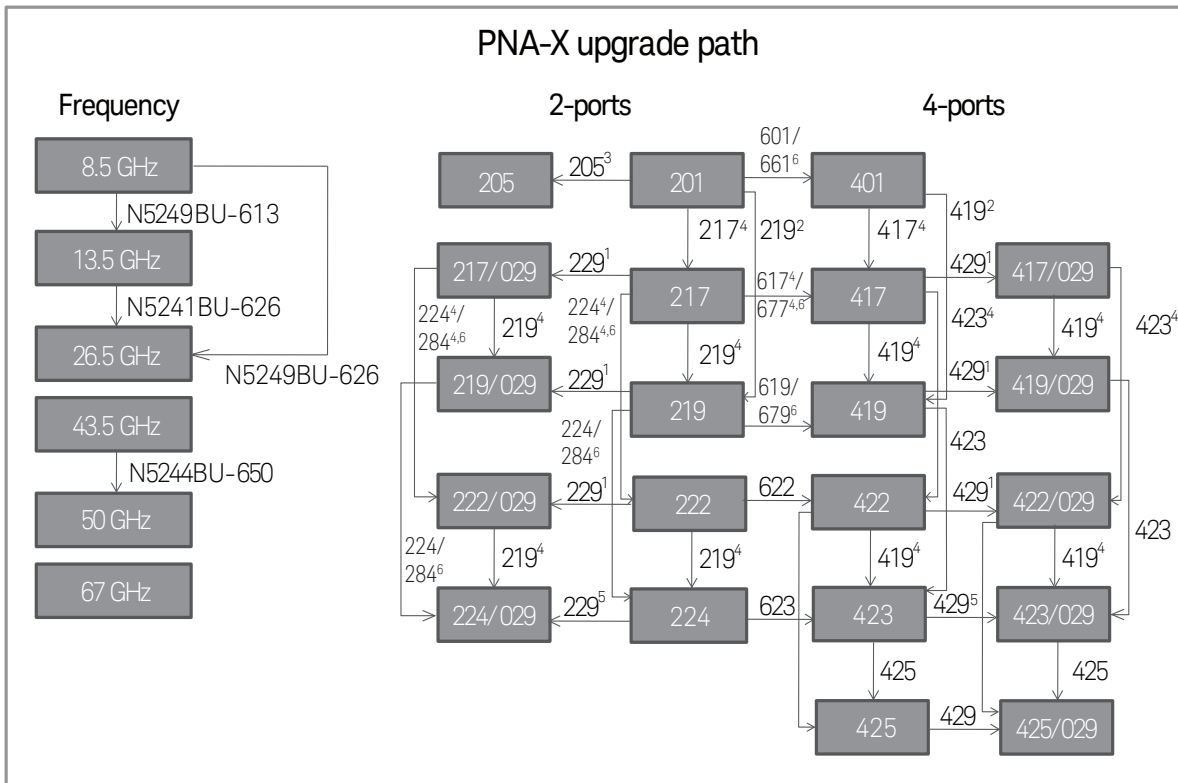

1. This upgrade path only available for N5241/42/49B.
2. This upgrade path only available for N5247B.
3. This upgrade path only available for N5241/42B.
4. This upgrade path only available for N5241/2/4/5/9B.
5. N5244B/45B requires s/n 5200xxxx and above.
6. When the DDS source is already installed

PNA Family Network Analyzer Upgrade Kits (Continued)

Upgrade paths

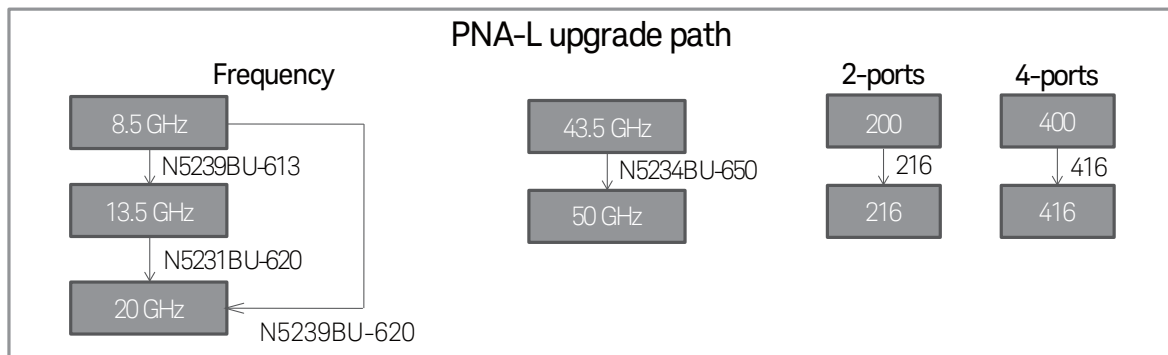
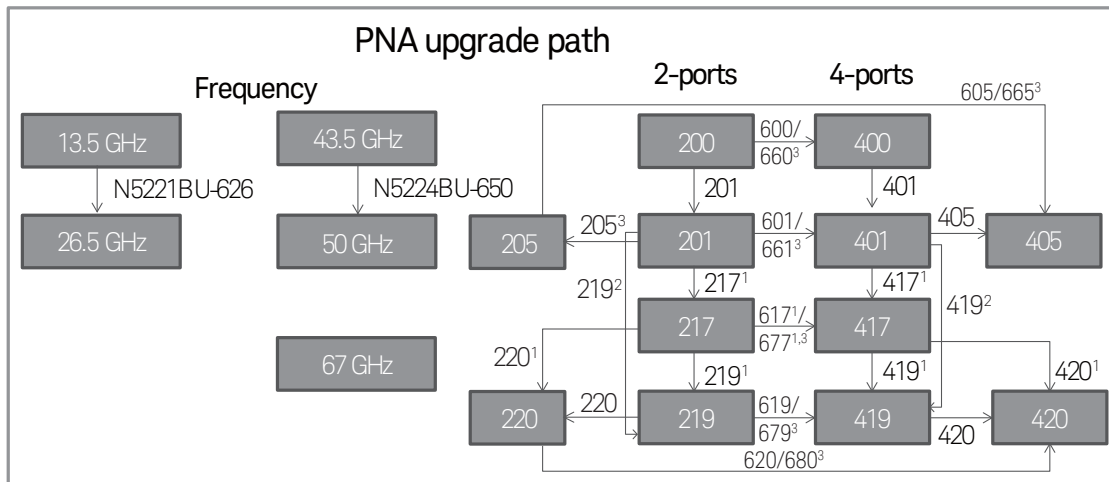

1. This upgrade path only available for N5221/22/24/25B
2. This upgrade path only available for N5227B
3. When the DDS source is already installed

Learn more at: www.keysight.com

For more information on Keysight Technologies' products, applications or services, please contact your local Keysight office. The complete list is available at: www.keysight.com/find/contactus

