

Keysight N432A Thermistor Power Meter

Technical Overview

Introduction

The new N432A power meter is the replacement model for the 432A power meter, offering enhancements and exciting features. This new N432A thermistor power meter works perfectly with the Keysight Technologies temperature-compensated thermistor mount sensors, which are models 478A and 8478B. Together with these sensors, the power meter can measure RF power from -30 dBm to $+10$ dBm and covers the frequency range from 100 kHz to 18 GHz. It is the most accurate power meter Keysight has to offer, with meter accuracy of $\pm (0.1\%+0.5 \text{ uW})$.



Quick Fact Sheet

The N432A operates on the basis of the DC self-balancing Wheatstone bridge, which will be explained in more details on page 3. As a result, the N432A is the only RF power meter with DC substitution measurement, converting RF power to DC measurements such as voltage (V) and resistance (Ω).

This thermistor is used mostly in metrology or calibration labs worldwide, to calibrate power meters and sensors and in any application which requires accurate RF power measurement.

Thermistor Mount

A thermistor is a resistor whose electrical resistance changes substantially with changes in temperature. Most thermistors are negative temperature coefficient (NTC) devices and are usually made of a metallic oxide compound. This means the resistance of the thermistor decreases as temperature rises, as shown in the resistance-vs-temperature curve in Figure 1. However, there are also thermistors which have positive temperature coefficient (PTC). In this case, the resistance increases when temperature rises. Currently, Keysight offers two RF power sensors based on the thermistor mount concept with NTC characteristics; they are 478A and the 8478B shown in Figure 2.

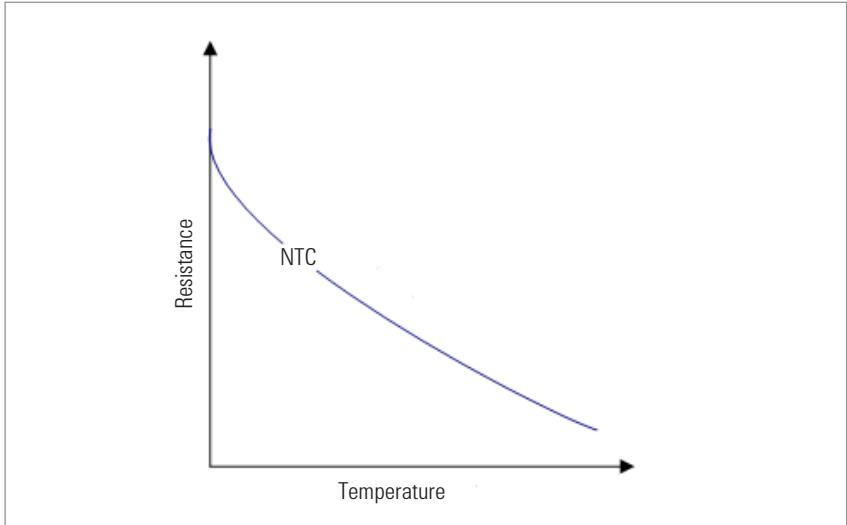

Figure 1. NTC curve of thermistor resistor



Figure 2. Keysight 478A and 8478B thermistor mount RF power sensors

DC Self-Balancing Bridge

As mentioned earlier, the N432A operates on the basis of the Wheatstone self-balancing bridge shown in Figure 3. Starting from the thermistor mount, when RF power is applied to it, radiating heat will cause the thermistor resistance (R_T) to decrease. The bolometer current source (controlled by the differential amplifier) is then adjusted to decrease the bias until the resistance rises back to the value it had before power was applied. At this stage, the differential input of the amplifier are equal to zero.

The whole process creates a self-balancing bridge or auto null condition. The null condition is created when $R_1/R_T = R_2/R_3$. In the N432A power meter, R_1 is the resistor value set by the user on the front panel to match the resistor of the thermistor mount sensor used. Also, R_2/R_3 is equal to one as both resistors are $1\text{ k}\Omega$. The change of bias power required to restore the thermistor to the same resistance is therefore equal to the power dissipated in the thermistor mount.

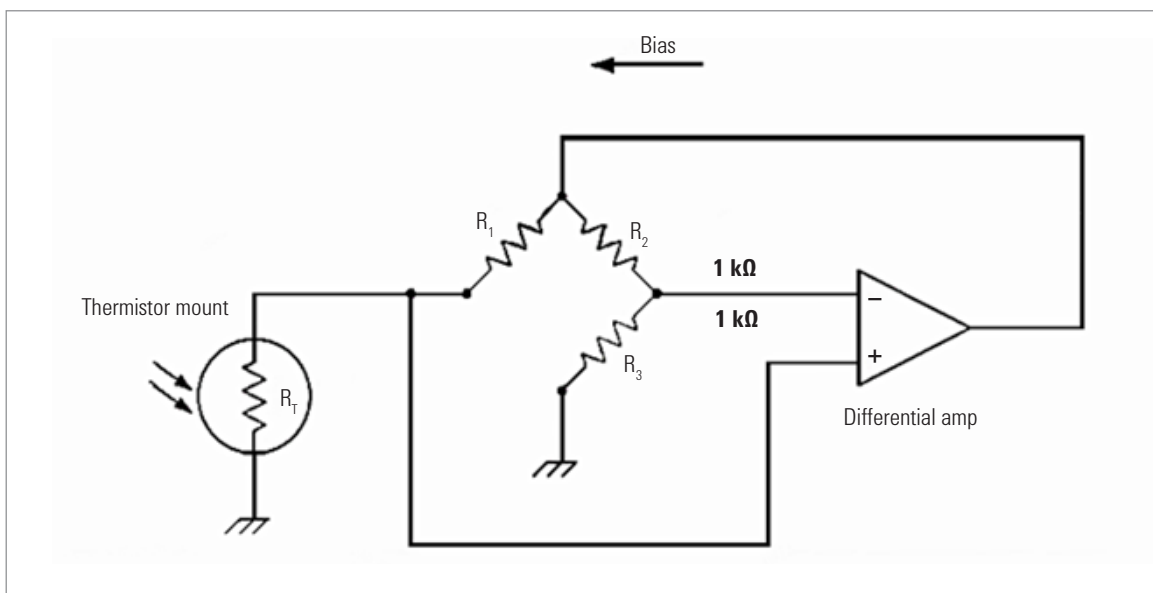

Figure 3. DC Wheatstone self-balancing bridge

Theory of Operation

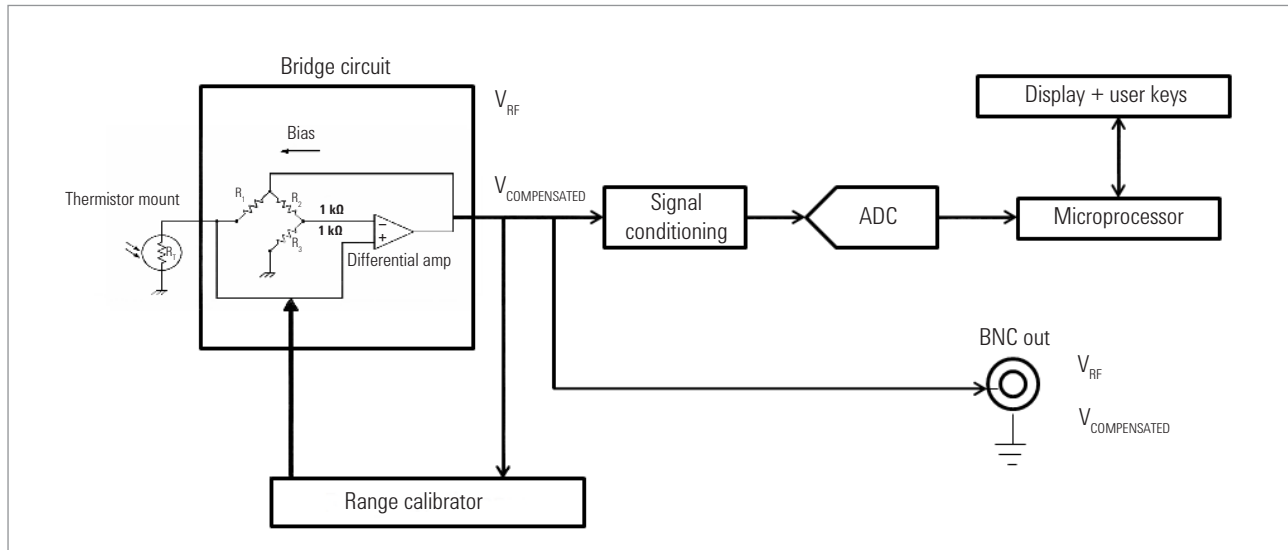

Figure 4. DC simplified N432A electrical block diagram

Equation 1

$$P = \frac{I}{4R} \{ [2V_{COMP1} V_1 - V_1^2] - [2V_{COMP0} V_0 - V_0^2] \}$$

Bridge circuits consist of two separate DC self-balancing bridges. The first bridge is called the RF bridge, detecting the RF power, and the second is called the compensated bridge, to compensate for environment temperature drift. This is because the thermistor will have different characteristic curves at different ambient temperatures. The readings of the ambient thermistor are used to correct the readings of the sensor thermistor. This dual bridge operation is called compensated mode.

During operation, both bridges will be balanced as explained previously. Both voltages at the top of bridges, V_{RF} and $V_{COMPENSATED}$ will be fed to the signal conditioning block for buffering and gain adjustment, gain adjustment and then will be fed to the meter ADC. At the signal conditioning block, V_0 and V_1 will be measured as well. The V_0 and V_1 are the voltages needed to compute the power measurement based on Equation 1 above.

From Equation 1, V_0 is the bridge voltage difference ($V_{COMPENSATED} - V_{RF}$) when there is no RF power applied to the thermistor mount sensor. Conversely, V_1 is the bridge voltage difference ($V_{COMPENSATED} - V_{RF}$) when RF power is applied. R is the thermistor resistance value. V_{COMP0} is the $V_{COMPENSATED}$ value when no RD power is applied to the thermistor mount sensor. Lastly, V_{COMP1} is the $V_{COMPENSATED}$ value when RF power is applied to the thermistor mount sensor.

The ADC digitizes all the voltage measurements from the DC bridges; the internal microprocessor will compute the power measurement and then display the results on the front LCD. The users can select which measurement results to be displayed, from power measurement (dBm, Watts) to the voltage measurements (V_{RF} , $V_{COMPENSATED}$, V_0 , and V_1). This whole digitization works much like a built-in digital voltmeter (DVM) inside the N432A, and therefore it gives an equivalent 6.5 digit DVM voltage measurement.

However, there are some applications where more accurate measurement is needed. This is why the N432A still provides the voltages to be measured using external DVM at the BNC connector (rear panel of the meter).

The N432A also has a built-in range calibrator circuit to supply a DC source to the DC bridge during calibration. Calibration can be done periodically depending on the users requirements.

The calibration process refers to external DVM through (the rear panel of the meter V_{RF} and $V_{COMPENSATED}$) BNC connections. The process calibrates the DC bridge circuit to the ADC block. With this feature, users can calibrate the N432A on their site without sending it to the factory or service center. In most cases, the calibration process will be traceable via the DVM, using the Keysight 3458A Digital Multimeter, 8.5 digit.

N432A Application Example

One of the main applications of N432A is the calibration of the power meter reference calibrator, the 50 MHz, 0 dBm source. The measurement setup is shown in Figure 5 below. The external 3458A standard DMM is optional, and will depend on the test or the calibration requirement of the user.

The purpose of the test is to check whether the 50 MHz, 0 dBm reference calibrator is within the manufacturer specification. This is done because the N432A system (plus the 478A option H75 or H76) has a very low measurement uncertainty of less than 1%. Hence the N432A system is suitable for testing and checking whether the power meter reference calibrator is within or beyond the specification. Normally, the lab operator will define statistically a detail measurement uncertainty calculation table to obtain the total uncertainty or error.

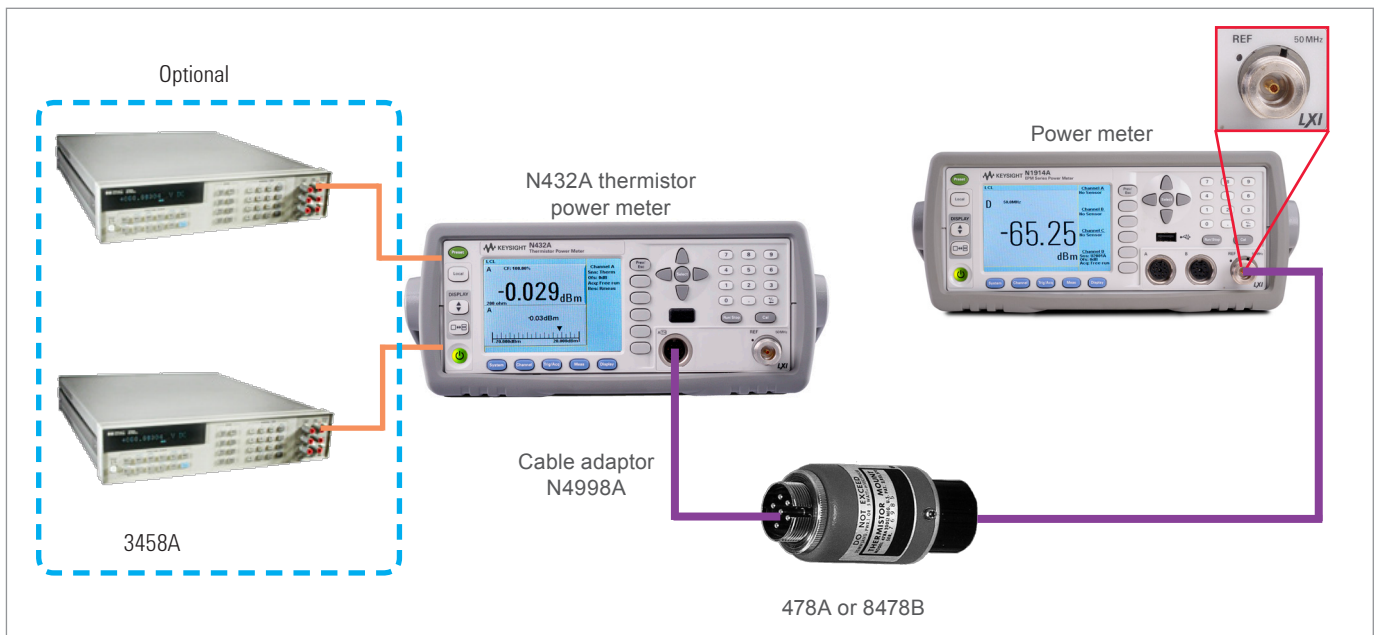

Figure 5. 1 mW reference source calibration using N432A and thermistor mount sensor

Thermistor Mount Power Sensors Compatibility

Thermistor sensor model	Frequency range (GHz)	Operating resistance (Ω)
478A	0.01 to 10	200
478A Option H63	0.000001 to 1	200
478A Option H75	0.001 to 1	200
478A Option H76	0.001 to 1	200
8478B	0.01 to 18	200

myKeysight

[myKeysight](#)

www.keysight.com/find/mykeysight

A personalized view into the information most relevant to you.



www.axistandard.org

AdvancedTCA® Extensions for Instrumentation and Test (AXIe) is an open standard that extends the AdvancedTCA for general purpose and semiconductor test. Keysight is a founding member of the AXIe consortium.



www.lxistandard.org

LAN eXtensions for Instruments puts the power of Ethernet and the Web inside your test systems. Keysight is a founding member of the LXI consortium.



www.pxisa.org

PCI eXtensions for Instrumentation (PXI) modular instrumentation delivers a rugged, PC-based high-performance measurement and automation system.



Three-Year Warranty

www.keysight.com/find/ThreeYearWarranty

Keysight's commitment to superior product quality and lower total cost of ownership. The only test and measurement company with three-year warranty standard on all instruments, worldwide.



Keysight Assurance Plans

www.keysight.com/find/AssurancePlans

Up to five years of protection and no budgetary surprises to ensure your instruments are operating to specification so you can rely on accurate measurements.



www.keysight.com/quality

Keysight Electronic Measurement Group
DEKRA Certified ISO 9001:2008
Quality Management System

Keysight Channel Partners

Get the best of both worlds: Keysight's measurement expertise and product breadth, combined with channel partner convenience.

www.keysight.com/find/N432A

For more information on Keysight Technologies' products, applications or services, please contact your local Keysight office. The complete list is available at: www.keysight.com/find/contactus

Americas

Canada	(877) 894 4414
Brazil	55 11 33 51 7010
Mexico	001 800 254 2440
United States	(800) 829 4444

Asia Pacific

Australia	1 800 629 485
China	800 810 0189
Hong Kong	800 938 693
India	1 800 112 929
Japan	0120 (421) 345
Korea	080 769 0800
Malaysia	1 800 888 848
Singapore	1 800 375 8100
Taiwan	0800 047 866
Other AP Countries	(65) 375 8100

Europe & Middle East

Belgium	32 (0) 2 404 93 40
Denmark	45 45 80 12 15
Finland	358 (0) 10 855 2100
France	0825 010 700* *0.125 €/minute
Germany	49 (0) 7031 464 6333
Ireland	1890 924 204
Israel	972-3-9288-504/544
Italy	39 02 92 60 8484
Netherlands	31 (0) 20 547 2111
Spain	34 (91) 631 3300
Sweden	0200-88 22 55
United Kingdom	44 (0) 118 927 6201

For other unlisted countries:

www.keysight.com/find/contactus

(BP-04-29-14)

