

# Keysight 11904S 2.4 mm/2.92 mm Adapter Set

# Notices

## Copyright Notice

© Keysight Technologies 2012 - 2019

No part of this manual may be reproduced in any form or by any means (including electronic storage and retrieval or translation into a foreign language) without prior agreement and written consent from Keysight Technologies as governed by United States and international copyright laws.

## Manual Part Number

11904-90009

## Edition

Edition 6, February 20, 2019

## Printed in:

Printed in Malaysia

## Published by:

Keysight Technologies  
Bayan Lepas Free Industrial Zone,  
11900 Penang, Malaysia

## Technology Licenses

The hardware and/or software described in this document are furnished under a license and may be used or copied only in accordance with the terms of such license.

## Declaration of Conformity

Declarations of Conformity for this product and for other Keysight products may be downloaded from the Web. Go to <http://www.keysight.com/go/conformity>. You can then search by product number to find the latest Declaration of Conformity.

## U.S. Government Rights

The Software is "commercial computer software," as defined by Federal Acquisition Regulation ("FAR") 2.101. Pursuant to FAR 12.212 and 27.405-3 and Department of Defense FAR Supplement ("DFARS") 227.7202, the U.S. government acquires commercial computer software under the same terms by which the software is customarily provided to the public. Accordingly, Keysight provides the Software to U.S. government customers under its standard commercial license, which is embodied in its End User License Agreement (EULA), a copy of which can be found at <http://www.keysight.com/find/sweula>. The license set forth in the EULA represents the exclusive authority by which the U.S. government may use, modify, distribute, or disclose the Software. The EULA and the license set forth therein, does not require or permit, among other things, that Keysight: (1) Furnish technical information related to commercial computer software or commercial computer software documentation that is not customarily provided to the public; or (2) Relinquish to, or otherwise provide, the government rights in excess of these rights customarily provided to the public to use, modify, reproduce, release, perform, display, or disclose commercial computer software or commercial computer software documentation. No additional government requirements beyond those set forth in the EULA shall apply, except to the extent that those terms, rights, or licenses are explicitly required from all providers of commercial computer software pursuant to the FAR and the DFARS and are set forth specifically in writing elsewhere in the EULA. Keysight shall be under no obligation to update, revise or otherwise modify the Software. With respect to any technical data as defined by FAR 2.101, pursuant to FAR 12.211 and 27.404.2 and DFARS 227.7102, the U.S. government acquires no greater than Limited Rights as defined in FAR 27.401 or DFAR 227.7103-5 (c), as applicable in any technical data.

## Warranty

THE MATERIAL CONTAINED IN THIS DOCUMENT IS PROVIDED "AS IS," AND IS SUBJECT TO BEING CHANGED, WITHOUT NOTICE, IN FUTURE EDITIONS. FURTHER, TO THE MAXIMUM EXTENT PERMITTED BY APPLICABLE LAW, KEYSIGHT DISCLAIMS ALL WARRANTIES, EITHER EXPRESS OR IMPLIED, WITH REGARD TO THIS MANUAL AND ANY INFORMATION CONTAINED HEREIN, INCLUDING BUT NOT LIMITED TO THE IMPLIED WARRANTIES OF MERCHANTABILITY AND FITNESS FOR A PARTICULAR PURPOSE. KEYSIGHT SHALL NOT BE LIABLE FOR ERRORS OR FOR INCIDENTAL OR CONSEQUENTIAL DAMAGES IN CONNECTION WITH THE FURNISHING, USE, OR PERFORMANCE OF THIS DOCUMENT OR OF ANY INFORMATION CONTAINED HEREIN. SHOULD KEYSIGHT AND THE USER HAVE A SEPARATE WRITTEN AGREEMENT WITH WARRANTY TERMS COVERING THE MATERIAL IN THIS DOCUMENT THAT CONFLICT WITH THESE TERMS, THE WARRANTY TERMS IN THE SEPARATE AGREEMENT SHALL CONTROL.

## Safety Information

### CAUTION

A CAUTION notice denotes a hazard. It calls attention to an operating procedure, practice, or the like that, if not correctly performed or adhered to, could result in damage to the product or loss of important data. Do not proceed beyond a CAUTION notice until the indicated conditions are fully understood and met.



### WARNING

A WARNING notice denotes a hazard. It calls attention to an operating procedure, practice, or the like that, if not correctly performed or adhered to, could result in personal injury or death. Do not proceed beyond a WARNING notice until the indicated conditions are fully understood and met.

## Certification

Keysight Technologies certifies that this product met its published specifications at the time of shipment from the factory. Keysight Technologies further certifies that its calibration measurements are traceable to the United States National Institute of Standards and Technology (NIST, formerly NBS), to the extent allowed by the Institute’s calibration facility, and to the calibration facilities of the other International Standards Organization members.

## Regulatory Markings

	<p>The CE mark is a registered trademark of the European Community. This CE mark shows that the product complies with all the relevant European Legal Directives.</p>		<p>The CSA mark is a registered trademark of the Canadian Standards Association.</p>
<p><b>ICES/NMB-001</b></p>	<p>ICES/NMB-001 indicates that this ISM device complies with the Canadian ICES-001. Cet appareil ISM est conforme a la norme NMB-001 du Canada.</p>	<p><b>ISM 1-A</b></p>	<p>This text indicates that the instrument is an Industrial Scientific and Medical Group 1 Class A product (CISPER 11, Clause 4).</p>
	<p>This symbol indicates the time period during which no hazardous or toxic substance elements are expected to leak or deteriorate during normal use. Forty years is the expected useful life of the product.</p>		

## Waste Electrical and Electronic Equipment (WEEE) Directive

This instrument complies with the WEEE Directive marking requirement. This affixed product label indicates that you must not discard this electrical or electronic product in domestic household waste.

### Product category:

With reference to the equipment types in the WEEE directive Annex 1, this instrument is classified as a “Monitoring and Control Instrument” product.

The affixed product label is as shown below.



Do not dispose in domestic household waste.

To return this unwanted instrument, contact your nearest Keysight Service Center, or visit <http://about.keysight.com/en/companyinfo/environment/takeback.shtml> for more information.

## Sales and Technical Support

To contact Keysight for sales and technical support, refer to the support links on the following Keysight websites:

- [www.keysight.com/find/adapters](http://www.keysight.com/find/adapters)  
(product-specific information and support, software and documentation updates)
- [www.keysight.com/find/assist](http://www.keysight.com/find/assist)  
(worldwide contact information for repair and service)

# Table of Contents

Certification	3
Regulatory Markings	3
Waste Electrical and Electronic Equipment (WEEE) Directive	4
Product category:	4
Sales and Technical Support	4
List of Figures	7
List of Tables	9
<b>1 General Information</b>	
Adapter Set Overview	12
Adapter set contents	12
Calibration definitions	12
Adapters (2.4 mm and 2.92 mm)	12
Connector adapter sets documented in this manual	12
Equipment required but not supplied	12
Incoming Inspection	13
Clarifying the Sex of Connectors	14
Preventive Maintenance	15
<b>2 Specifications</b>	
Environmental Requirements	18
Temperature – what to watch out for	18
Mechanical Characteristics	19
Pin depth	19
Electrical Specifications	21
Residual errors after calibration	21
Certification	21
<b>3 Use, Maintenance, and Care of the Devices</b>	
Electrostatic Discharge	24
Visual Inspection	25
Look for obvious defects and damage first	25
What causes connector wear?	25
Inspect the mating plane surfaces	25
Slotted connectors (2.92 mm)	26
Precision slotless connectors (2.4 mm)	26
Calibration Information	27
Full two-port calibration overview	27
Two-port calibration procedures	28
Cleaning the Connectors	30

Gaging Connectors	32
Connector gage accuracy	32
When to gage connectors	32
Gaging Procedures	33
Gaging 2.4 mm and 2.92 mm connectors	33
Connections	36
How to make a connection	36
Final connection using a torque wrench	36
How to separate a connection	38
Operational Check	39
Connect the 2.4 mm lowband load	39
Handling and Storage	42
<b>4 Performance Verification</b>	
Introduction	44
How Keysight Verifies the Devices in Your Kit	45
Recertification	46
How often to recertify	46
Where to send a kit for recertification	46
<b>5 Troubleshooting</b>	
Troubleshooting Process	48
Returning a Kit or Device to Keysight	49
Where to look for more information	49
How Keysight Verifies the Devices in Your Kit	50
Recertification	51
How often to recertify	51
Where to send a kit for recertification	51

# List of Figures

- Figure 2-1 Connector pin depth ..... 19
- Figure 3-1 ESD protection setup ..... 24
- Figure 3-2 Full two-port calibration - Keysight 8510 VNA using calibration kit definition CK\_292MMA3 and higher ..... 28
- Figure 3-3 Gaging 2.4 mm and 2.92 mm connectors ..... 35
- Figure 3-4 Wrench positions ..... 37
- Figure 3-5 Using the torque wrench ..... 37
- Figure 3-6 2.4 mm to 2.92 mm adapter to lowband load ..... 39
- Figure 3-7 2.4 mm to 2.92 mm adapter to sliding load ..... 41
- Figure 5-1 Troubleshooting flowchart ..... 48

THIS PAGE HAS BEEN INTENTIONALLY LEFT BLANK.



## List of Tables

Table 1-1	Clarifying the sex of connectors: examples	14
Table 2-1	Environmental specifications	18
Table 2-2	Pin depth limits	20
Table 2-3	Electrical specifications	21
Table 3-1	Torque wrench information	36

THIS PAGE HAS BEEN INTENTIONALLY LEFT BLANK.

# 1 General Information

Adapter Set Overview	12
Incoming Inspection	13
Clarifying the Sex of Connectors	14
Preventive Maintenance	15

This chapter provides you with an overview of the 11904S adapter set.

## Adapter Set Overview

The Keysight 11904S adapter set is designed to give network analyzer systems with 2.4 mm test ports (such as the Keysight 8510, 8722, and the PNA Series) the ability to perform measurements on devices with 2.92 mm connectors. The set can be used to achieve calibrated measurements of 2.92 mm devices up to 40 GHz, and 2.4 mm devices up to 50 GHz.

### Adapter set contents

The basic 11904S adapter set includes the following items:

- User's and Service Guide (x 1)
- 2.4 mm to 2.92 mm adapters (x 4)
- 5/16 in, 56 N-cm (5 in-lb) torque wrench for use on the 2.92 mm connectors (x 1)
- Open-end wrench for the 7 mm flats on some of the components (x 1)

### Calibration definitions

The calibration definitions are for you to use with your analyzer. Refer to your network analyzer *User's Guide*, or embedded *Help* for information on modifying the calibration kit standard definitions.

#### **8510**

- 2.92 mm A.3, contains modified standards data to account for the adapters, which are inserted after a 2.4 mm calibration is performed.
- 2.4 mm A.4, contains calibration definitions for only the 2.4 mm devices.

### Adapters (2.4 mm and 2.92 mm)

Like the other devices in the kit, the adapters are built to very tight tolerances to provide good broadband performance and to ensure stable, repeatable connections.

The adapters are designed so that their nominal electrical lengths are the same, which allows them to be used in calibration procedures for non-insertable devices (such as adapter removal).

The male 2.4 mm and 2.92 mm connectors are metrology grade. The female PSC-2.4 mm is a metrology-grade, precision slotless connector. The female 2.92 mm connectors have slotted contacts and therefore cannot be considered metrology grade. Due to the extremely thin wall of the 2.92 mm female connector, a slotless metrology grade 2.92 mm connector pair does not currently exist.

### Connector adapter sets documented in this manual

The part numbers provided in this manual are the recommended replacement parts for this set. The devices in this set should meet the specifications published in this manual.

### Equipment required but not supplied

Some items are required or recommended for successful operation of your kit, but are not supplied with the kit.

## Incoming Inspection

To verify the electrical performance of the devices in this set, see [Chapter 4, "Performance Verification"](#).

Check for damage. The foam-lined storage case provides protection during shipping. If the case or any device appears damaged, or if the shipment is incomplete, refer to the Keysight contact numbers located at the end of this manual. Keysight will arrange for repair or replacement of incomplete or damaged shipments without waiting for a settlement from the transportation company. See ["Returning a Kit or Device to Keysight"](#) on page 49.

## Clarifying the Sex of Connectors

In this document and in the prompts of the PNA calibration wizard, the sex of cable connectors and adapters is referred to in terms of the center conductor. For example, a connector or device designated as 1.85 mm –f– has a 1.85 mm female center conductor.

**8510-Series, 872x, and 875x ONLY:** In contrast, during a measurement calibration, the network analyzer softkey menus label a 1.85 mm calibration device with reference to the sex of the analyzer’s test port connector—not the calibration device connector. For example, the label SHORT(F) refers to the short that is to be connected to the female test port. This will be a male short from the calibration kit.

**Table 1-1** Clarifying the sex of connectors: examples

Terminology	Meaning
Short –f–	Female short (female center conductor)
Short (f)	Male short (male center conductor) to be connected to female port

A connector gage is referred to in terms of the connector that it measures. For instance, a male connector gage has a female connector on the gage so that it can measure male devices.

## Preventive Maintenance

The best techniques for maintaining the integrity of the devices in the kit include:

- routine visual inspection
- routine cleaning
- proper gaging
- proper connection techniques

All of these are described in [Chapter 3, "Use, Maintenance, and Care of the Devices"](#). Failure to detect and remove dirt or metallic particles on a mating plane surface can degrade repeatability and accuracy and can damage any connector mated to it. Improper connections, resulting from pin depth values being out of the observed limits (see [Table 2-2](#) on page 20) or from bad connection techniques, can also damage these devices.

THIS PAGE HAS BEEN INTENTIONALLY LEFT BLANK.



## 2 Specifications

Environmental Requirements	18
Mechanical Characteristics	19
Electrical Specifications	21

This chapter provides the environmental requirements, mechanical characteristics, and electrical specifications of the 11904S adapter set.

## Environmental Requirements

The Keysight 8497K Attenuator is designed to fully comply with Keysight Technologies' product operating environmental specifications as shown in [Table 2-1](#).

**Table 2-1** Environmental specifications

Parameter	Limits
<b>Temperature</b>	
- Operating <sup>[a]</sup>	- +20 °C to +26 °C
- Storage	- -40 °C to +75 °C
- Error-corrected range <sup>[b]</sup>	- ± 1 °C of measurement calibration temperature
<b>Altitude</b>	
- Operating	- < 4,500 meters (≈15,000 feet)
- Storage	- < 15,000 meters (≈50,000 feet)
<b>Relative humidity</b>	
	Always non-condensing
- Operating	- 0 to 80% (26 °C maximum dry bulb)
- Storage	- 0 to 90%

[a] The temperature range over which the calibration standards maintain conformance to their specifications.

[b] The allowable network analyzer ambient temperature drift during measurement calibration and during measurements when the network analyzer error correction is turned on. Also, the range over which the network analyzer maintains its specified performance while correction is turned on.

### Temperature – what to watch out for

Changes in temperature can affect electrical characteristics. Therefore, the operating temperature is a critical factor in performance. During a measurement calibration, the temperature of the calibration devices must be stable and within the range shown in [Table 2-1](#).

#### CAUTION

Avoid unnecessary handling of the devices during calibration because your fingers act as a heat source and may increase the temperature of the device.

## Mechanical Characteristics

Mechanical characteristics such as center conductor protrusion and pin depth are not performance specifications. They are, however, important supplemental characteristics related to electrical performance. Keysight Technologies verifies the mechanical characteristics of the devices in the kit with special gaging processes and electrical testing.

This ensures that the device connectors do not exhibit any center conductor protrusion or improper pin depth when the kit leaves the factory.

“[Gaging Connectors](#)” on page 32 explains how to use gages to determine if the kit devices have maintained their mechanical integrity. Refer to [Table 2-2](#) for typical and observed pin depth limits.

### Pin depth

Pin depth is the distance the center conductor mating plane differs from being flush with the outer conductor mating plane. See [Figure 2-1](#). The pin depth of a connector can be in one of two states: either protruding or recessed.

**Protrusion** is the condition in which the center conductor extends beyond the outer conductor mating plane. This condition will indicate a positive value on the connector gage.

**Recession** is the condition in which the center conductor is set back from the outer conductor mating plane. This condition will indicate a negative value on the connector gage.

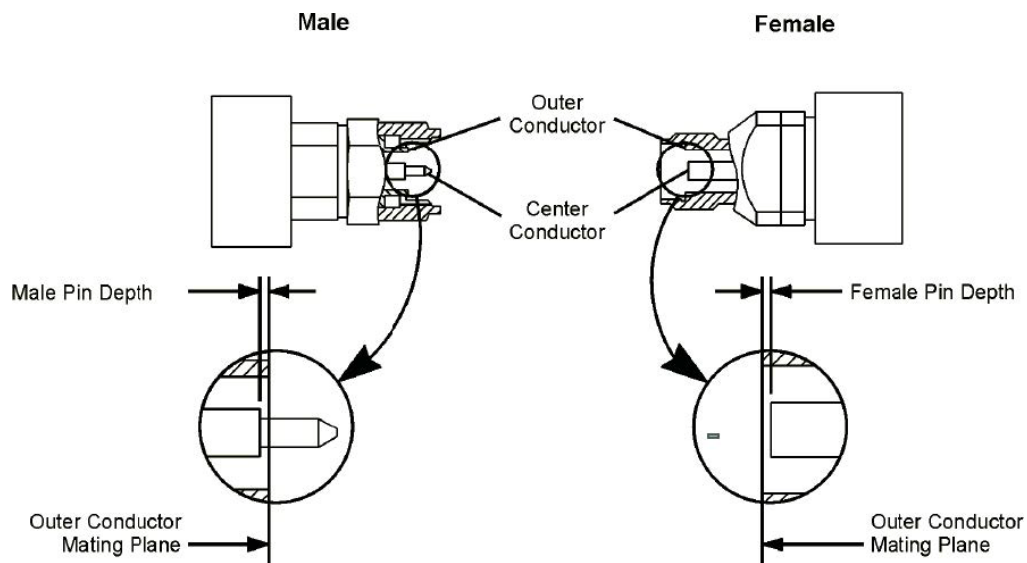

**Figure 2-1** Connector pin depth

The pin depth value of each calibration device in the kit is not specified, but is an important mechanical parameter. The electrical performance of the device depends, to some extent, on its pin depth. The electrical specifications for each device in the kit take into account the effect of pin depth on the device’s performance. [Table 2-2](#) lists the typical pin depths and measurement uncertainties, and provides observed pin depth limits for the devices in the kit. If the pin depth of a device does not measure within the observed pin depth limits, it may be an indication that the device fails to meet electrical specifications. Refer to [Figure 2-1](#) for a visual representation of proper pin depth (slightly recessed).

**Table 2-2** Pin depth limits

Device	Typical pin depth	Measurement uncertainty <sup>[a]</sup>	Observed pin depth limits <sup>[b]</sup>
Opens	0 to -0.0127 mm	+0.0030 to -0.0030 mm	+0.0030 to -0.0157 mm
	0 to -0.00050 in	+0.00012 to -0.00012 in	+0.00012 to -0.00062 in
Shorts	0 to -0.0127 mm	+0.0015 to -0.0015 mm	+0.0015 to -0.0142 mm
	0 to -0.00050 in	+0.00006 to -0.00006 in	+0.00006 to -0.00056 in
Fixed loads	-0.0025 to -0.0203 mm	+0.0030 to -0.0030 mm	+0.00050 to -0.0234 mm
	-0.0001 to -0.00080 in	+0.00012 to -0.00012 in	+0.00002 to -0.00092 in
Adapters (2,4 to 2.4)	-0 to -0.0381 mm	+0.0030 to -0.0030 mm	+0.0030 to -0.0411 mm
	-0 to -0.00150 in	+0.00012 to -0.00012 in	+0.00012 to -0.00162 in
Adapters (2.4 to 2.92) <sup>[c]</sup>	0 to -0.0381 mm	+0.0030 to -0.0030 mm	+0.0030 to -0.0411 mm
	0 to -0.00150 in	+0.00012 to -0.00012 in	+0.00012 to -0.00162 in
Sliding loads	0 to -0.0127 mm	+0.0015 to -0.0015 mm	+0.0015 to -0.0142 mm
	0 to -0.00050 in	+0.00006 to -0.00006 in	+0.00006 to -0.00056 in

[a] Approximately +2 sigma to -2 sigma of gage uncertainty based on studies done at the factory according to recommended procedures.

[b] Observed pin depth limits are the range of observation limits seen on the gage reading due to measurement uncertainty. The depth could still be within specifications.

[c] 2.4 mm to 2.92 mm adapters require a 3.5 mm connector gage to measure the 2.92 mm end.

When measuring pin depth, the measured value (resultant average of three or more measurements) is not the true value. Always compare the measured value with the observed pin depth limits in [Table 2-2](#) to evaluate the condition of device connectors.

## Electrical Specifications

The electrical specifications in [Table 2-3](#) apply to the devices in your calibration kit when connected with a Keysight precision interface.

**Table 2-3** Electrical specifications

Device	Frequency	Parameter	Specification
Adapter	DC to 40 GHz	Return loss	$\leq 24$ dB

### Residual errors after calibration

The 8510 “Specifications and Performance Verification” software can be used to obtain a printout of the residual errors after a calibration has been performed. Refer to the “Specifications and Performance Verification” section of the *8510C On-Site Service Manual* for information on how to use the software.

### Certification

Keysight Technologies certifies that this product met its published specifications at the time of shipment from the factory. Keysight further certifies that its calibration measurements are traceable to the United States National Institute of Standards and Technology (NIST) to the extent allowed by the institute’s calibration facility, and to the calibration facilities of other International Standards Organization members. See [“How Keysight Verifies the Devices in Your Kit”](#) on page 50 for more information.

THIS PAGE HAS BEEN INTENTIONALLY LEFT BLANK.

# 3 Use, Maintenance, and Care of the Devices

Electrostatic Discharge	24
Visual Inspection	25
Calibration Information	27
Cleaning the Connectors	30
Gaging Connectors	32
Gaging Procedures	33
Connections	36
Operational Check	39
Handling and Storage	42

This chapter teaches you how to use, maintain, and provide care for the 11904S adapter set.

## Electrostatic Discharge

Protection against ESD (electrostatic discharge) is essential while connecting, inspecting, or cleaning connectors attached to a static-sensitive circuit (such as those found in test sets). Static electricity can build up on your body and can easily damage sensitive internal circuit elements when discharged. Static discharges too small to be felt can cause permanent damage. Devices such as calibration components and devices under test (DUTs), can also carry an electrostatic charge. To prevent damage to the test set, components, and devices:

- always wear a grounded wrist strap having a 1 M $\Omega$  resistor in series with it when handling components and devices or when making connections to the test set.
- always use a grounded, conductive table mat while making connections.
- always wear a heel strap when working in an area with a conductive floor. If you are uncertain about the conductivity of your floor, wear a heel strap.
- always ground yourself before you clean, inspect, or make a connection to a static-sensitive device or test port. You can, for example, grasp the grounded outer shell of the test port or cable connector briefly.
- always ground the center conductor of a test cable before making a connection to the analyzer test port or other static-sensitive device. This can be done as follows:
  - 1 Connect a short (from your calibration kit) to one end of the cable to short the center conductor to the outer conductor.
  - 2 While wearing a grounded wrist strap, grasp the outer shell of the cable connector.
  - 3 Connect the other end of the cable to the test port.
  - 4 Remove the short from the cable.

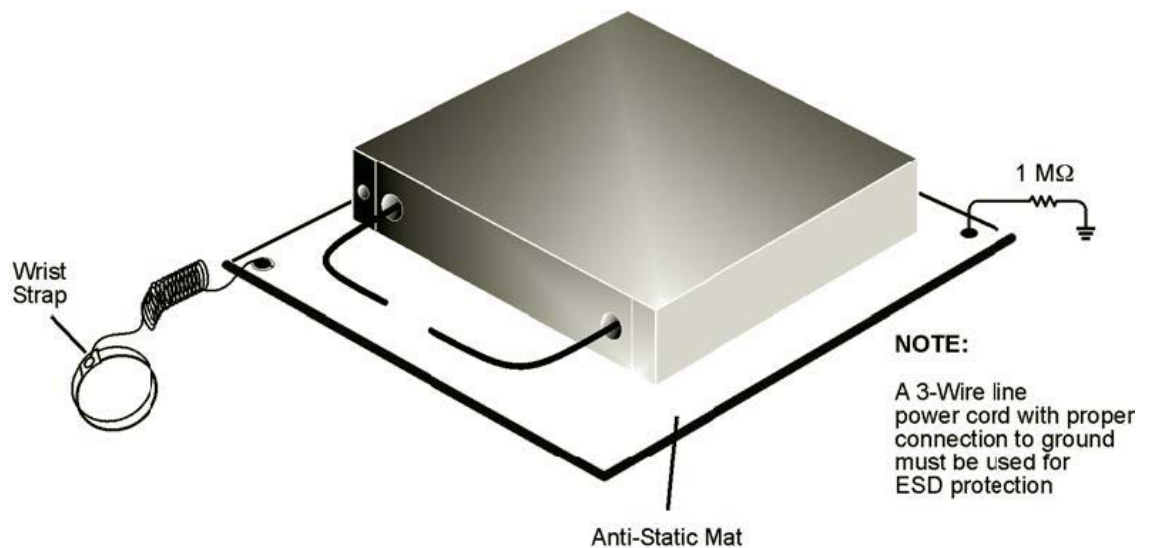

**Figure 3-1** ESD protection setup



## Visual Inspection

Visual inspection and, if necessary, cleaning should be done every time a connection is made. Metal particles from the connector threads may fall into the connector when it is disconnected. One connection made with a dirty or damaged connector can damage both connectors beyond repair.

In some cases, magnification is necessary to see damage to a connector; a magnifying device with a magnification of  $\leq 10x$  is recommended. However, not all defects that are visible only under magnification will affect the electrical performance of the connector. Use the following guidelines when evaluating the integrity of a connector.

### Look for obvious defects and damage first

Examine the connectors first for obvious defects and damage: badly worn plating on the connector interface, deformed threads, or bent, broken, or misaligned center conductors. Connector nuts should move smoothly and be free of burrs, loose metal particles, and rough spots.

### What causes connector wear?

Connector wear is caused by connecting and disconnecting the devices. The more use a connector gets, the faster it wears and degrades. The wear is greatly accelerated when connectors are not kept clean, or are not connected properly.

Connector wear eventually degrades performance of the device. Calibration devices should have a long life if their use is on the order of a few times per week. Replace devices with worn connectors.

The test port connectors on the network analyzer test set may have many connections each day, and are, therefore, more subject to wear. It is recommended that an adapter be used as a test port saver to minimize the wear on the test set's test port connectors.

### Inspect the mating plane surfaces

Flat contact between the connectors at all points on their mating plane surfaces is required for a good connection. See [Figure 2-1](#). Look especially for deep scratches or dents, and for dirt and metal particles on the connector mating plane surfaces. Also look for signs of damage due to excessive or uneven wear or misalignment.

Light burnishing of the mating plane surfaces is normal, and is evident as light scratches or shallow circular marks distributed more or less uniformly over the mating plane surface. Other small defects and cosmetic imperfections are also normal. None of these affect electrical or mechanical performance.

If a connector shows deep scratches or dents, particles clinging to the mating plane surfaces, or uneven wear, clean and inspect it again. Devices with damaged connectors should be discarded. Determine the cause of damage before connecting a new, undamaged connector in the same configuration.

## Slotted connectors (2.92 mm)

When using slotted connectors, inspect the contact fingers in the female center conductor carefully. These can be bent or broken, and damage to them is not always easy to see. A connector with damaged contact fingers will not make good electrical contact and must be replaced.

### NOTE

**This is particularly important when mating non-precision to precision devices.**

---

## Precision slotless connectors (2.4 mm)

The female 2.4 mm connectors in this set are metrology-grade, precision slotless connectors (PSC). Precision slotless connectors are used to improve accuracy. A characteristic of metrology-grade connectors is directly traceability to national measurement standards through their well-defined mechanical dimensions. With PSCs on test ports and standards, the accuracy achieved when measuring at 50 dB return loss levels is comparable to using conventional slotted connectors measuring devices having only 30 dB return loss. This represents an accuracy improvement of about 10 times.

The female 2.92 mm connectors have slotted contacts and, therefore, cannot be considered metrology-grade. Due to the extremely thin wall of the 2.92 mm female connector, a slotless metrology-grade 2.92 mm connector pair does not currently exist.

*Conventional* female center conductors are slotted and, when mated, are flared by the male pin. Because physical dimensions determine connector impedance, this change in physical dimension affects electrical performance, making it very difficult to perform precision measurements with conventional slotted connectors.

The precision slotless connector was developed to eliminate this problem. The PSC has a center conductor with a solid cylindrical shell, the outside diameter of which does not change when mated. Instead, the center conductor has an internal contact that flexes to accept the male pin.

## Calibration Information

The calibration procedure for using the Keysight 11904S adapters requires that a 2.4 mm calibration be done using the calibration definitions of the 11904S instead of the calibration definitions of the Keysight 85056A 2.4 mm calibration kit. Although response, 1-Port, and 1-Path 2-Port calibrations may also be done, the following section is a general overview of a full 2-Port calibration, as it is the most complex of the calibrations.

When performing a response calibration, leave the adapters connected and do not load the calibration definitions of this 11904S adapter set. Refer to your network analyzer documentation or embedded help for step-by-step calibration procedures and system uncertainty information.

### Full two-port calibration overview

The method used to achieve calibrated 2.92 mm connector measurements involves calibrating both 2.4 mm test ports using 2.4 mm calibration standards: opens, shorts, and loads. For Option 001 Kits, both the low band load and sliding load are used. The test ports need not be insertable. Then, two 2.4 mm to 2.92 mm adapters are connected back-to-back between the test ports to provide the “thru” measurements. For example, if the test port connectors are both female 2.4 mm connectors, a 2.4 mm male to 2.92 mm female adapter mated with a 2.92 mm male to 2.4 mm female adapter can be used as the “thru”. This method provides a better transmission calibration than using the 2.4 mm ports as the thru.

The key to this calibration method lies in the modified standard definitions. The nominal 2.4 mm open and short circuit standard definitions are modified to account for the presence of the 2.4 mm to 2.92 mm adapters after calibration. The measurements of the 2.4 mm standard are effectively translated to the ends of the adapters so that the directivity, source match, and reflection tracking error terms are transformed to the ends of the adapters. The thru measurements made with the 2.4 mm to 2.92 mm adapter pair accounts for the length and loss of the adapters that are inserted after the 2.4 mm calibration. The load match and transmission tracking error terms are directly characterized at the 2.92 mm mating plane.

This calibration method assumes that the adapters being used have equal length and loss, and that they are reflectionless. The metrology-grade adapters (2.4 mm to 2.4 mm only) and the 2.4 mm to 2.92 mm adapter are designed and manufactured with very tight tolerances and therefore exhibit very similar transmission characteristics. They may be interchanged, to measure non-insertables, without much degradation in performance. The actual return loss of the adapters has the most impact on the effective directivity, source match, and load match of the system. The 2.4 mm calibration residual errors are degraded proportionally by the return loss of the adapters. It is approximately equal to the RSS (adapter reflection coefficient, 2.4 mm calibration residual errors). The reflection tracking degradation is a function of the difference between the assumed loss and delay characteristics of the 2.4 mm/2.92 mm adapters and the actual transmission characteristics of the adapters.

For best 2.92 mm measurement accuracy, a precision 2.92 mm calibration kit, such as the Keysight N4692A Electronic Calibration Module or the Maury Microwave 8770S mechanical calibration kit, is recommended.

## Two-port calibration procedures

**NOTE**

The following procedures are applicable using the specified calibration kit definition files. If the VNA has an earlier version of the calibration kit definition file, obtain a copy of the latest file from Keysight Technologies.

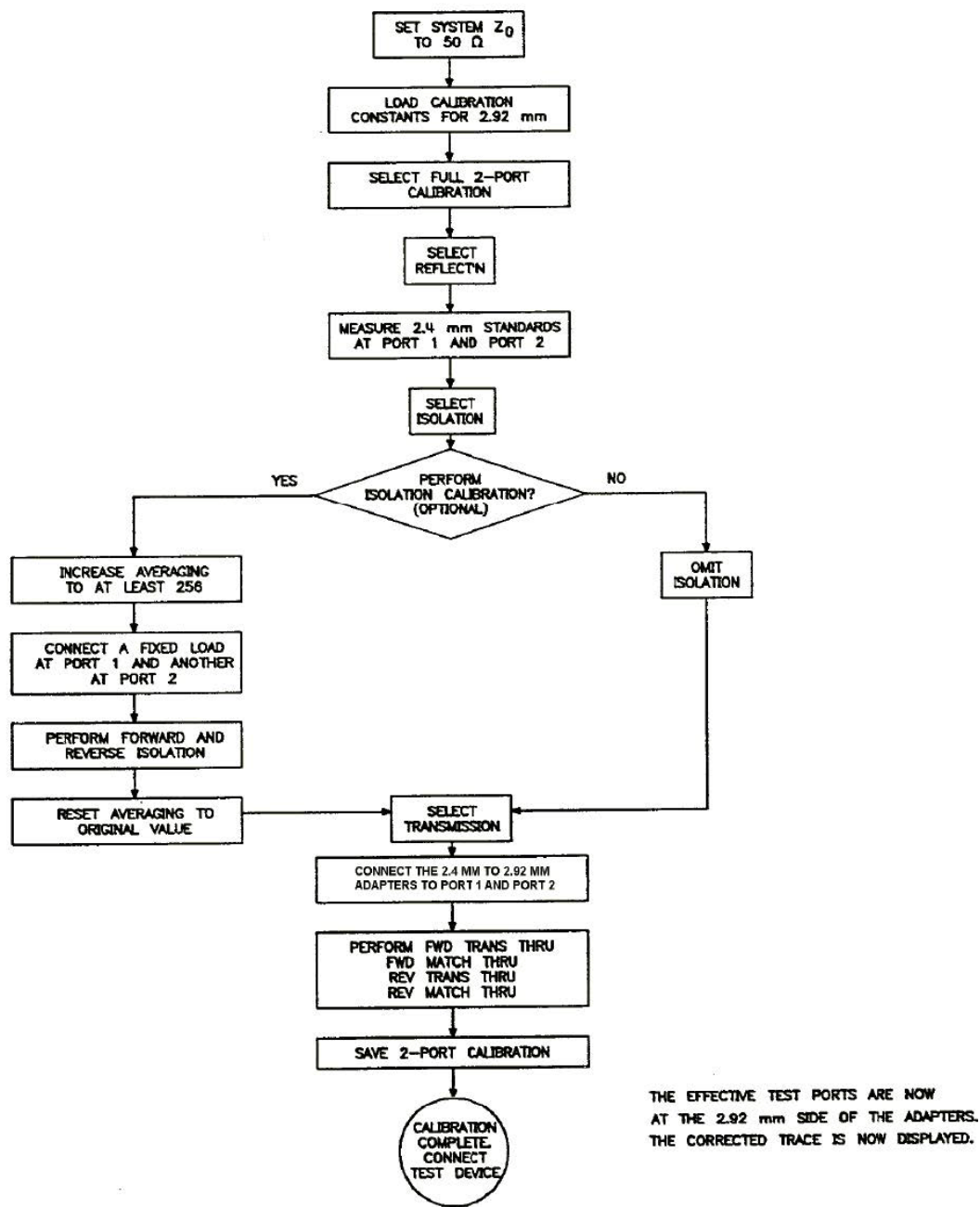

**Figure 3-2** Full two-port calibration - Keysight 8510 VNA using calibration kit definition CK\_292MMA3 and higher

The Keysight PNA series of network analyzers provides two calibration procedures for mechanical calibration kits: the “Smart” Cal and the “Unguided” Cal. The “Smart” Cal guides you through the calibration process by providing step by step instructions. It also has many powerful built-in calibration features that can simplify the steps required to calibrate the PNA. Because the 85056K 2.4 mm/2.92 mm Calibration Kit operates differently from a standard calibration kit, the following procedure is recommended:

#### **PNA smart cal calibration procedure for the 85065K and 85056K01 cal kits**

- 1 From the **CALIBRATION** menu, click **CALIBRATION WIZARD**.
- 2 Select **SMART CAL**, and click **Next**.
- 3 At the **SELECT DUT CONNECTORS** dialog, choose the device connector type and sex. Always choose an insertable combination, such as 2.92 mm female on port-1 and 2.92 mm male on port-2.

#### **NOTE**

If the 2.92 mm connector selection is not available, click **Cancel** to exit Calibration Wizard. Click **ADVANCED MODIFY CAL KIT**, click **IMPORT**, then select the cal kit files. Return to the Calibration Wizard.

- 4 At **SELECT CAL KITS** dialog, select either **85056K Broadband Load Cal Kit** or **85056K01 Sliding load Cal Kit** for both ports.
- 5 Click **Next** to perform the calibration steps. DO NOT connect the 2.4 mm to 2.92 mm adapters to the 2.4 mm test ports until instructed to do so. The 2.4 mm test ports are calibrated first. When instructed to connect the 2.4 mm/2.92 mm adapter pair (thru standards) to the test ports, connect the appropriate adapters back- to- back to the 2.4 mm test ports.
- 6 If the 2.92 mm device being tested is non-insertable, swap out one of the 2.4 mm to 2.92 mm adapter with one that will mate with the test device.

#### **PNA unguided cal calibration procedure for the 85065K and 85056K01 cal kits**

- 1 Ensure System Z0 it is set to 50 ohms. Click **SYSTEM** then **CONFIGURE**, then **SYSTEM Z0**.
- 2 From the **CALIBRATION** menu, click **CALIBRATION WIZARD**.
- 3 Select **UNGUIDED CAL**.
- 4 Select **FULL SOLT 2-PORT** and check **VIEW OR SELECT CAL KIT**.
- 5 Select the **85056K Broadband Load Cal Kit** or **85056K01 Sliding load Cal Kit**.

#### **NOTE**

- If the 2.92 mm cal kit is not available, then click **Cancel** to exit the calibration wizard. Click **ADVANCED MODIFY CAL KIT**, click **IMPORT**, then select the cal kit files. Return to the Calibration Wizard
- The PNA refers to the connector sex of the calibration standard, NOT the test port.

- 6 When measuring the THRU standard, connect the 2.4 mm/2.92 mm adapter pair (thru standards) to the test ports.
- 7 If the 2.92 mm device being tested is a non-insertable, swap out one of the 2.4 mm to 2.92 mm adapters with one that will mate with the test device.

## Cleaning the Connectors

### 1 Use compressed air or nitrogen

#### WARNING

Always use protective eyewear when using compressed air or nitrogen.

Use compressed air (or nitrogen) to loosen particles on the connector mating plane surfaces. Clean air cannot damage a connector or leave particles or residues behind.

You can use any source of clean, dry, low-pressure compressed air or nitrogen that has an effective oil-vapor filter and liquid condensation trap placed just before the outlet hose.

Ground the hose nozzle to prevent electrostatic discharge, and set the air pressure to less than 414 kPa (60 psi) to control the velocity of the air stream. High-velocity streams of compressed air can cause electrostatic effects when directed into a connector. These electrostatic effects can damage the device. Refer to “[Electrostatic Discharge](#)” on page 24 in this chapter for additional information.

### 2 Clean the connector threads

#### WARNING

- Keep isopropyl alcohol away from heat, sparks, and flame. Store in a tightly closed container. It is extremely flammable. In case of fire, use alcohol foam, dry chemical, or carbon dioxide; water may be ineffective.
- Use isopropyl alcohol with adequate ventilation and avoid contact with eyes, skin, and clothing. It causes skin irritation, may cause eye damage, and is harmful if swallowed or inhaled. It may be harmful if absorbed through the skin. Wash thoroughly after handling.
- In case of spill, soak up with sand or earth. Flush spill area with water.
- Dispose of isopropyl alcohol in accordance with all applicable federal, state, and local environmental regulations.

Use a lint-free swab or cleaning cloth moistened with isopropyl alcohol to remove any dirt or stubborn contaminants on a connector that cannot be removed with compressed air or nitrogen.

- a** Apply a small amount of isopropyl alcohol to a lint-free cleaning swab.
- b** Clean the connector threads.
- c** Let the alcohol evaporate, then blow the threads dry with a gentle stream of clean, low-pressure compressed air or nitrogen. Always completely dry a connector before you reassemble or use it.

### 3 Clean the mating plane surface

- a Apply a small amount of isopropyl alcohol to a lint-free cleaning swab.
- b Clean the center and outer conductor mating plane surfaces. Refer to [Figure 2-1](#). When cleaning a female connector, avoid snagging the swab on the center conductor contact fingers by using short strokes.
- c Let the alcohol evaporate, then blow the connector dry with a gentle stream of clean, low-pressure compressed air or nitrogen. Always completely dry a connector before you reassemble or use it.

### 4 Inspect

Inspect the connector to make sure that no particles or residue remain. Refer to [“Visual Inspection”](#) on page 25.

## Gaging Connectors

The gages available from Keysight Technologies are intended for preventive maintenance and troubleshooting purposes only. They are effective in detecting excessive center conductor protrusion or recession and conductor damage on DUTs, test accessories, and the calibration kit devices. They are especially useful in determining if the pin depths of sliding loads are grossly out of adjustment. Do not use the gages for precise pin depth measurements.

### Connector gage accuracy

The connector gages are only capable of performing coarse measurements. They do not provide the degree of accuracy necessary to precisely measure the pin depth of the kit devices. This is partially due to the repeatability uncertainties that are associated with the measurement. Only the factory-through special gaging processes and electrical testing—can accurately verify the mechanical characteristics of the devices.

With proper technique, the gages are useful in detecting gross pin depth errors on device connectors. To achieve maximum accuracy, random errors must be reduced by taking the average of at least three measurements having different gage orientations on the connector. Even then, the resultant average can be in error by as much as  $\pm 0.0001$  inch due to systematic (biasing) errors usually resulting from worn gages and gage masters.

The information in [Table 2-2](#) on page 20 assumes new gages and gage masters, therefore, these systematic errors were not included in the uncertainty analysis. As the gages undergo more use, the systematic errors can become more significant in the accuracy of the measurement.

The measurement uncertainties are primarily a function of the assembly materials and design, and the unique interaction each device type has with the gage. Therefore, these uncertainties can vary among the different devices. For example, note the difference between the uncertainties of the Open and Short in [Table 2-2](#) on page 20.

The *observed* pin depth limits add these uncertainties to the *typical* factory pin depth values to provide practical limits that can be referenced when using the gages.

#### NOTE

**When measuring pin depth, the measured value (resultant average of three or more measurements) contains measurement uncertainty and is not necessarily the true value. Always compare the measured value with the observed pin depth limits (which account for measurement uncertainties) in [Table 2-2](#) on page 20 to evaluate the condition of device connectors.**

### When to gage connectors

Gage a connector at the following times:

- Prior to using a device for the first time, record the pin depth measurement so that it can be compared with future readings. (It will serve as a good troubleshooting tool when you suspect damage may have occurred to the device.)
- If either visual inspection or electrical performance suggests that the connector interface may be out of typical range (due to wear or damage, for example).
- If a calibration device is used by someone else or on another system or piece of equipment.
- Initially, after every 100 connections, and after that, as often as experience indicates.



## Gaging Procedures

### Gaging 2.4 mm and 2.92 mm connectors

#### CAUTION

Never connect a 2.4 mm gage to a 2.92 mm device. You must use 3.5 mm gages to measure the pin depth of 2.92 mm devices.

#### NOTE

Always hold a connector gage by the gage barrel, below the dial indicator. This gives the best stability, and improves measurement accuracy. (Cradling the gage in your hand, or holding it by the dial applies stress to the gage plunger mechanism through the dial indicator housing.)

- 1 Select the proper gage for your connector. The 2.92 mm connectors are gaged with the same gages and in the same way as the precision 3.5 mm connectors. These are not the same gages that are used for the 2.4 mm connectors.
- 2 Inspect and clean the gage, gage master, and device to be gaged. Refer to “[Visual Inspection](#)” on page 25 and “[Cleaning the Connectors](#)” on page 30 earlier in this chapter.
- 3 Zero the connector gage (refer to [Figure 3-3](#)):
  - a While holding the gage by the barrel, and without turning the gage or the device, connect the gage to the gage master by interconnecting the male and female connectors. Connect the nut finger-tight. Do not overtighten.

#### NOTE

Refer to [Table 3-1](#) on page 36 for the connector type and torque setting information.

- b Using an open-end wrench to keep the device body from rotating, use the torque wrench, included in the kit, to tighten the connecting nut to the specified torque. Refer to “[Final connection using a torque wrench](#)” on page 36 for additional information.
  - c As you watch the gage pointer, gently tap the barrel of the gage to settle the reading. The gage pointer should line up exactly with the zero mark on the gage. If not, adjust the zero set knob until the gage pointer lines up exactly with the zero mark.
  - d Remove the gage master.
- 4 Gage the device connector (refer to [Figure 3-3](#)):
  - a While holding the gage by the barrel, and without turning the gage or the device, connect the gage to the device by interconnecting the male and female connectors. Connect the nut finger-tight. Do *not* overtighten.
  - b Using an open-end wrench to keep the device body from rotating, use the torque wrench, included in the kit, to tighten the connecting nut to the specified torque. Refer to “[Final connection using a torque wrench](#)” on page 36 for additional information.
  - c Gently tap the barrel of the gage with your finger to settle the gage reading.

- d** Read the gage indicator dial. Read only the black  $\pm$  signs; *not* the red  $\pm$  signs. For maximum accuracy, measure the connector a minimum of three times and take an average of the readings. After each measurement, rotate the gage a quarter-turn to reduce measurement variations that result from the gage or the connector face not being exactly perpendicular to the center axis.
- e** Compare the average reading with the observed pin depth limits in [Table 2-2](#) on page 20.

**Note:**

Although male devices are shown in this illustration, the procedure is essentially the same for female devices.

**Zero the Connector Gage**

- Connect the gage to the gage master.
- Torque the connecting nut.
- Gently tap the gage barrel to settle the reading.
- Using the zero set knob, adjust the gage pointer to line up exactly with the zero mark.
- Remove the gage master.

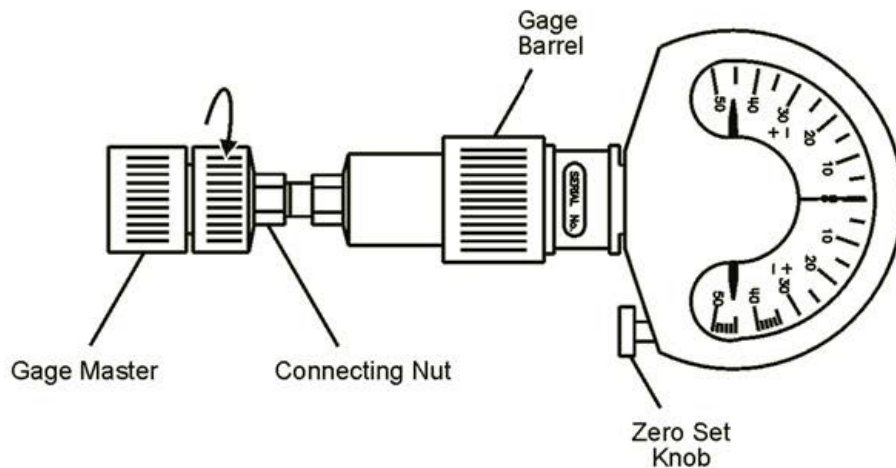
**Gage the Device Connector**

- Connect the gage to the device being measured.
- Torque the connecting nut.
- Gently tap the gage barrel to settle the reading.
- Read recession or protrusion from the gage.
- Remove the device.
- Repeat two additional times and average the three readings.

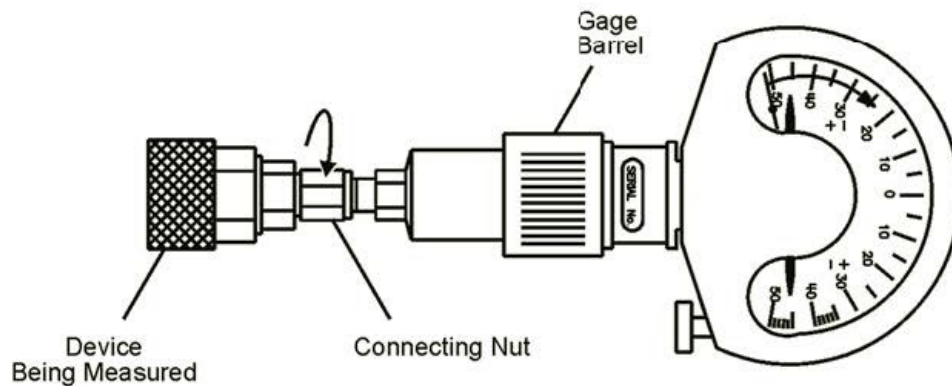

**Figure 3-3** Gaging 2.4 mm and 2.92 mm connectors

## Connections

Good connections require a skilled operator. The most common cause of measurement error is bad connections. The following procedures illustrate how to make good connections.

### How to make a connection

#### Preliminary connection

- 1 Ground yourself and all devices. Wear a grounded wrist strap and work on a grounded, conductive table mat. For ESD precautions refer to “[Electrostatic Discharge](#)” on page 24.
- 2 Visually inspect the connectors. Refer to “[Visual Inspection](#)” on page 25.
- 3 If necessary, clean the connectors. Refer to “[Cleaning the Connectors](#)” on page 30.
- 4 Use a connector gage to verify that all center conductors are within the observed pin depth values in [Table 2-2](#) on page 20.
- 5 Carefully align the connectors. The male connector center pin must slip concentrically into the contact finger of the female connector.

#### CAUTION

Do *not* turn the device body. Only turn the connector nut. Damage to the center conductor can occur if the device body is twisted.

- 6 Push the connectors straight together and tighten the connector nut finger tight. As the center conductors mate, there is usually slight resistance.
- 7 The preliminary connection is tight enough when the mating plane surfaces make uniform, light contact. Do not overtighten this connection.  
A connection in which the outer conductors make gentle contact at all points on both mating surfaces is sufficient. Very light finger pressure is enough to accomplish this.
- 8 Make sure the connectors are properly supported. Relieve any side pressure on the connection from long or heavy devices or cables.

### Final connection using a torque wrench

Use the appropriate torque wrench to make the final connection. [Table 3-1](#) provides information about the torque wrench required for the connector types found in this set.

**Table 3-1** Torque wrench information

Connector type	Torque setting	Torque tolerance
2.92 mm	56 N-cm (5 in-lb)	±5.6 N-cm (±0.5 in-lb)
2.4 mm	90 N-cm (8 in-lb)	±9.0 N-cm (±0.8 in-lb)

Using a torque wrench guarantees that the connection is not too tight, preventing possible connector damage. It also guarantees that all connections are equally tight each time.

Prevent the rotation of anything other than the connector nut that you are tightening. It may be possible to do this by hand if one of the connectors is fixed (as on a test port). However, it is recommended that you use an open-end wrench to keep the body of the device from turning.

- 1 Position both wrenches within 90 degrees of each other before applying force. See [Figure 3-4](#). Wrenches opposing each other (greater than 90 degrees apart) will cause a lifting action which can misalign and stress the connections of the devices involved. This is especially true when several devices are connected together.

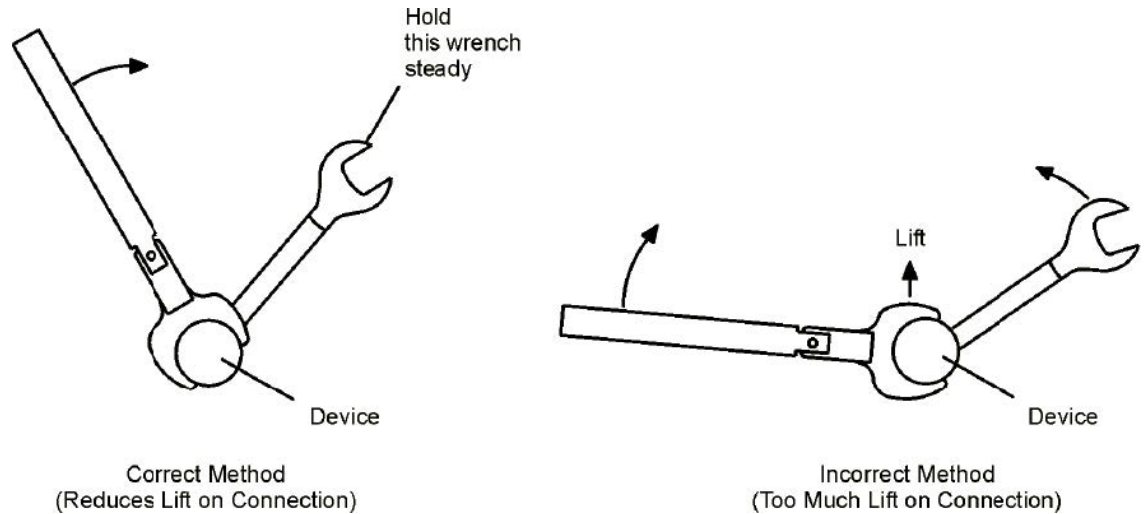

**Figure 3-4** Wrench positions

- 2 Hold the torque wrench lightly, at the end of the handle only (beyond the groove), as shown in [Figure 3-5](#).

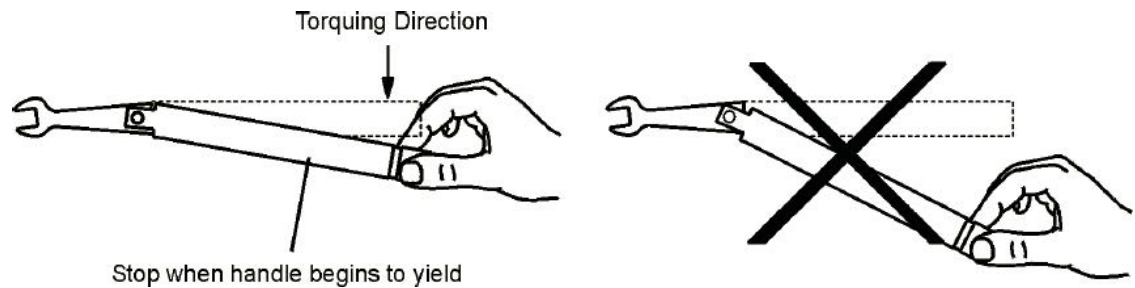

**Figure 3-5** Using the torque wrench

- 3 Apply downward force perpendicular to the wrench handle. This applies torque to the connection through the wrench. Do not hold the wrench so tightly that you push the handle straight down along its length rather than pivoting it; otherwise, you apply an unknown amount of torque.
- 4 Tighten the connection just to the torque wrench “break” point. The wrench handle gives way at its internal pivot point. Do not tighten the connection further. See [Figure 3-5](#).

### CAUTION

You don't have to fully break the handle of the torque wrench to reach the specified torque; doing so can cause the handle to kick back and loosen the connection. Any give at all in the handle is sufficient torque.

## How to separate a connection

To avoid lateral (bending) force on the connector mating plane surfaces, always support the devices and connections.

### CAUTION

Do *not* turn the device body. Only turn the connector nut. Damage to the center conductor can occur if the device body is twisted.

---

- 1 Use an open-end wrench to prevent the device body from turning.
- 2 Use another open-end wrench to loosen the connecting nut.
- 3 Complete the separation by hand, turning only the connecting nut.
- 4 Pull the connectors straight apart without twisting, rocking, or bending either of the connectors.

## Operational Check

The following procedure will give an indication of whether or not the adapters in this set are operating properly. This procedure does not verify any specification, but rather gives an indication of the return loss characteristics of the adapters. Any gross errors obtained after performing this check could indicate that the performance of one or both of the adapters checked is in question (two are checked at the same time).

### Connect the 2.4 mm lowband load

Refer to [Figure 3-6](#) for the following steps:

- 1 Perform an S11 1-Port calibration in 2.4 mm to 40 GHz using the calibration definitions of the 85056A 2.4 mm calibration kit. The calibration conditions are:
  - 250 ms sweep
  - 201 points
  - 16 averages
  - 2.4 mm sliding load cal

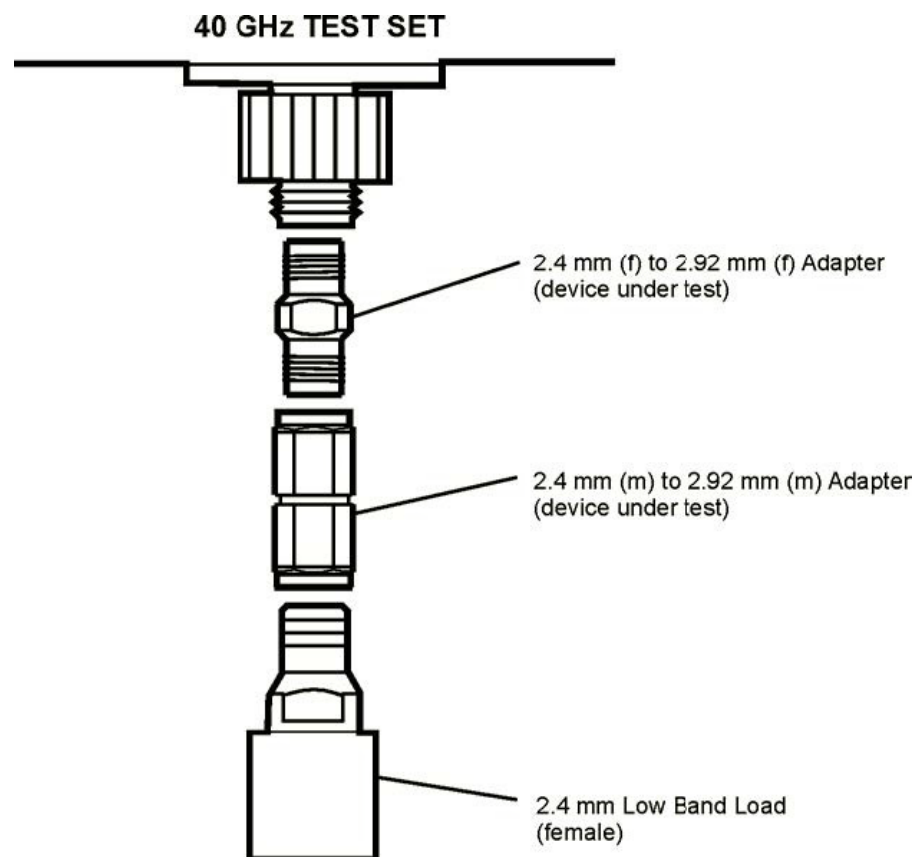

**Figure 3-6** 2.4 mm to 2.92 mm adapter to lowband load

- 2 Connect the 2.4 mm -f- to 2.92 mm -f- adapter to the calibrated test port.

- 3** Connect the 2.4 mm -m- to 2.92 mm -m- adapter to the adapter on the test port.
- 4** Connect the 2.4 mm lowband load -f- to the end of the adapter connected in step 3. The measured return loss should be > 28 dB from 45 MHz to 4 GHz. Refer to [Figure 3-7](#) for the following step:
- 5** Remove the lowband load and connect a 2.4 mm sliding load -f- to the adapter. Refer to the *85056A 2.4 mm Precision Calibration Kit* for information on connecting a sliding load. The return loss should be > 20 dB from 4GHz to 40 GHz.



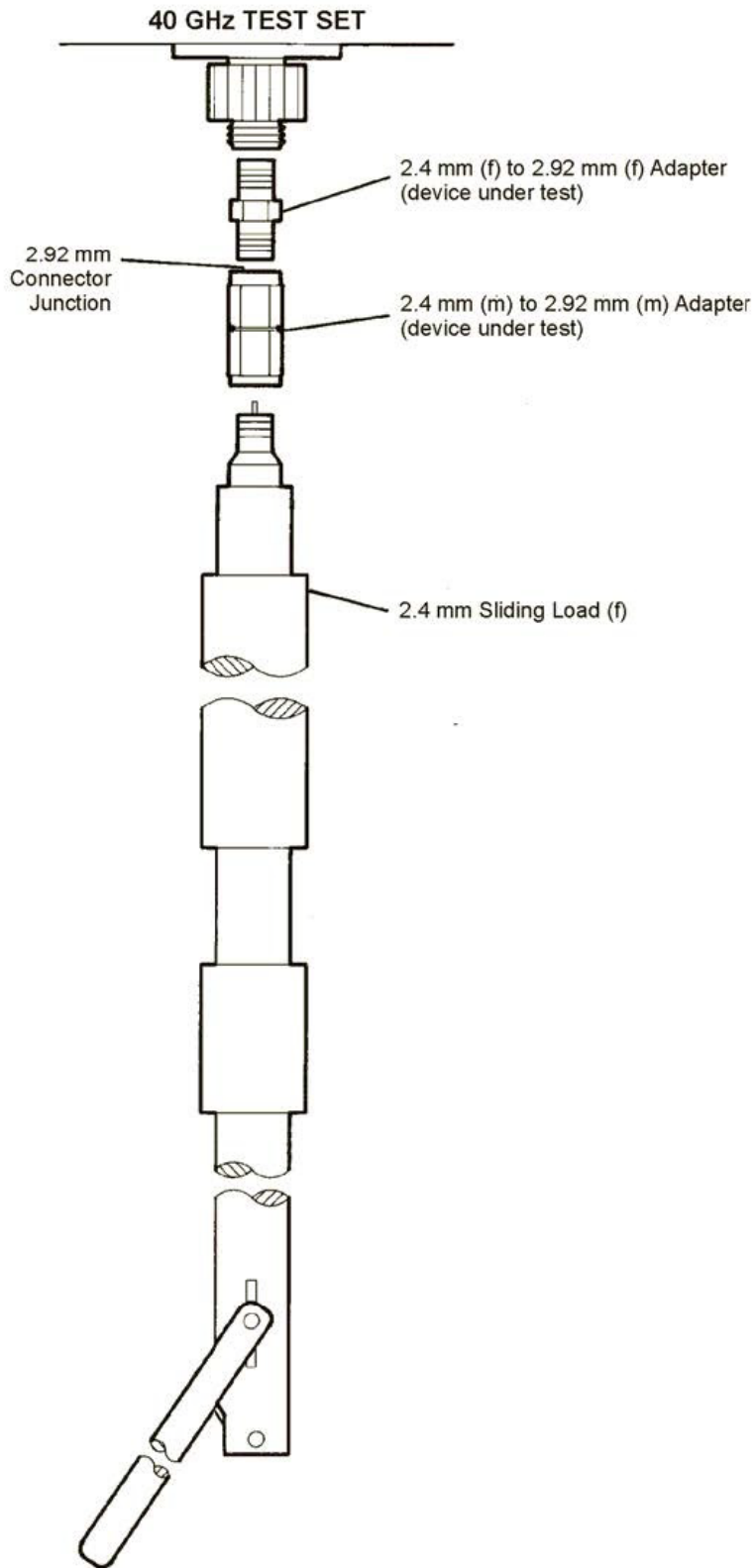

Figure 3-7 2.4 mm to 2.92 mm adapter to sliding load

## Handling and Storage

- Install the protective end caps and store the calibration devices in the foam-lined storage case when not in use.
- Never store connectors loose in a box, or in a desk or bench drawer. This is the most common cause of connector damage during storage.
- Keep connectors clean.
- Do not touch mating plane surfaces. Natural skin oils and microscopic particles of dirt are easily transferred to a connector interface and are very difficult to remove.
- Do not set connectors contact-end down on a hard surface. The plating and the mating plane surfaces can be damaged if the interface comes in contact with any hard surface.

## 4 Performance Verification

Introduction	44
How Keysight Verifies the Devices in Your Kit	45
Recertification	46

This chapter provides information on the recertification steps for the 11904S adapter set.

## Introduction

The performance of your adapter set can only be verified by returning the kit to Keysight Technologies for recertification. The equipment and calibration standards required to verify the specifications of the devices in the kit have been specially manufactured and are not commercially available.

## How Keysight Verifies the Devices in Your Kit

Keysight verifies the specifications of these devices as follows:

- 1** The residual microwave error terms of the test system are verified with precision airlines and shorts that are directly traced to the National Institute of Standards and Technology (NIST). The airline and short characteristics are developed from mechanical measurements. The mechanical measurements and material properties are carefully modeled to give very accurate electrical representation. The mechanical measurements are then traced to NIST through various plug and ring gages and other mechanical measurements.
- 2** Each calibration device is electrically tested on this system. For the initial (before sale) testing of the calibration devices, Keysight includes the test measurement uncertainty as a guardband to guarantee each device meets the published specification. For recertifications (after sale), no guardband is used and the measured data is compared directly with the specification to determine the pass or fail status. The measurement uncertainty for each device is, however, recorded in the calibration report that accompanies recertified kits.

These two steps establish a traceable link to NIST for Keysight to the extent allowed by the institute's calibration facility. The specifications data provided for the devices in the kit is traceable to NIST through Keysight Technologies.

## Recertification

The following will be provided with a recertified kit:

- a new calibration sticker affixed to the case
- a certificate of calibration
- a calibration report for each device in the kit listing measured values, specifications, and uncertainties

**NOTE**

A list of NIST traceable numbers may be purchased upon request to be included in the calibration report.

---

Keysight Technologies offers a Standard calibration for the recertification of the kit. For more information, contact Keysight Technologies.

### How often to recertify

The suggested initial interval for recertification is 12 months or sooner. The actual need for recertification depends on the use of the kit. After reviewing the results of the initial recertification, you may establish a different recertification interval that reflects the usage and wear of the kit.

**NOTE**

The recertification interval should begin on the date the kit is first used after the recertification date.

---

### Where to send a kit for recertification

Contact Keysight Technologies for information on where to send your kit for recertification. Refer to [“Returning a Kit or Device to Keysight”](#) on page 49 for details on sending your kit.

## 5 Troubleshooting

Troubleshooting Process	48
Returning a Kit or Device to Keysight	49
How Keysight Verifies the Devices in Your Kit	50
Recertification	51

This chapter provides basic troubleshooting instructions for the 11904S adapter set.

## Troubleshooting Process

This manual contains limited information about network analyzer system operation. For complete information, refer to the instrument documentation.

If you suspect a bad calibration, or if your network analyzer does not pass performance verification, follow the steps in [Figure 5-1](#).

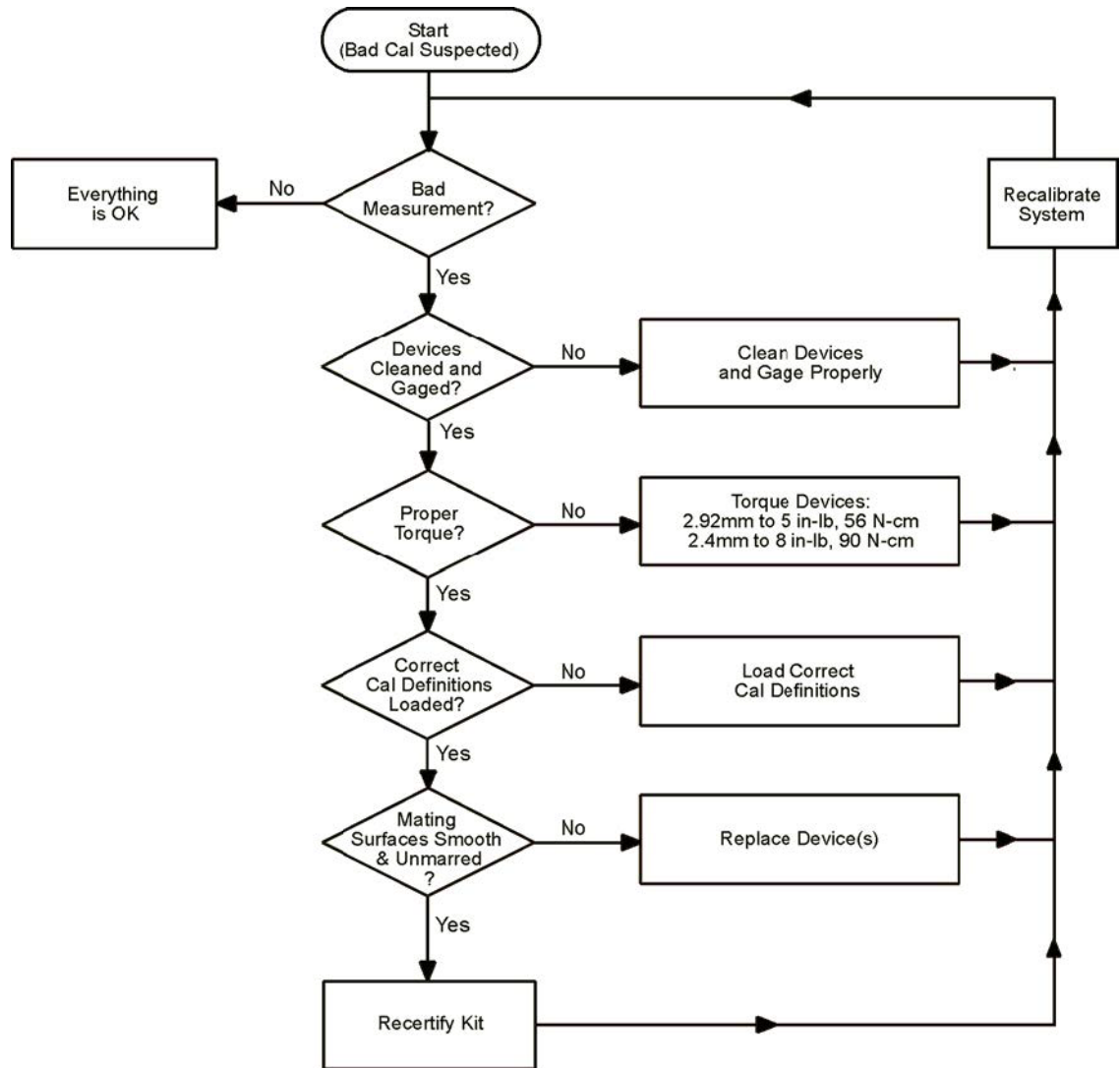

wh701d

**Figure 5-1** Troubleshooting flowchart



## Returning a Kit or Device to Keysight

If your kit or device requires service, contact Keysight Technologies for information on where to send it. See the end of this manual for contact information. Include a service tag (located near the end of this manual) on which you provide the following information:

- your company name and address
- a technical contact person within your company, and the person's complete telephone number
- the model number and serial number of the kit
- the part number and serial number of each device
- the type of service required
- a detailed description of the problem and how the device was being used when the problem occurred (such as calibration or measurement)

### Where to look for more information

This manual contains limited information about network analyzer system operation. For complete information, refer to the instrument documentation. If you need additional information, contact Keysight Technologies at <http://www.keysight.com/find/assist>

## How Keysight Verifies the Devices in Your Kit

Keysight verifies the specifications of these devices as follows:

- 1** The residual microwave error terms of the test system are verified with precision airlines and shorts that are directly traced to the National Institute of Standards and Technology (NIST). The airline and short characteristics are developed from mechanical measurements. The mechanical measurements and material properties are carefully modeled to give very accurate electrical representation. The mechanical measurements are then traced to NIST through various plug and ring gages and other mechanical measurements.
- 2** Each calibration device is electrically tested on this system. For the initial (before sale) testing of the calibration devices, Keysight includes the test measurement uncertainty as a guardband to guarantee each device meets the published specification. For recertifications (after sale), no guardband is used and the measured data is compared directly with the specification to determine the pass or fail status. The measurement uncertainty for each device is, however, recorded in the calibration report that accompanies recertified kits.

These two steps establish a traceable link to NIST for Keysight to the extent allowed by the institute's calibration facility. The specifications data provided for the devices in the kit is traceable to NIST through Keysight Technologies.

## Recertification

The following will be provided with a recertified kit:

- a new calibration sticker affixed to the case
- a certificate of calibration
- a calibration report for each device in the kit listing measured values, specifications, and uncertainties

**NOTE**

A list of NIST traceable numbers may be purchased upon request to be included in the calibration report.

---

Keysight Technologies offers a Standard calibration for the recertification of the kit. For more information, contact Keysight Technologies.

### How often to recertify

The suggested initial interval for recertification is 12 months or sooner. The actual need for recertification depends on the use of the kit. After reviewing the results of the initial recertification, you may establish a different recertification interval that reflects the usage and wear of the kit.

**NOTE**

The recertification interval should begin on the date the kit is first used after the recertification date.

---

### Where to send a kit for recertification

Contact Keysight Technologies for information on where to send your kit for recertification. Refer to [“Returning a Kit or Device to Keysight”](#) on page 49 for details on sending your kit.

THIS PAGE HAS BEEN INTENTIONALLY LEFT BLANK.



This information is subject to change without notice. Always refer to the Keysight website for the latest revision.

© Keysight Technologies 2012 - 2019  
Edition 6, February 20, 2019

Printed in Malaysia



11904-90009

[www.keysight.com](http://www.keysight.com)