

Keysight Technologies

Identifying and Solving GSM 850 Interferences with Public Safety Communications

Case Study by
Keysight and Bryant Solutions



Table of Contents

Background on Interference	3
Goals to Resolving Interference	4
Identifying Root Cause(s) of Interference	5
Identifying Solution(s) to Resolve Interference	15
Validating Solution on Wireless Operator Sites	16
Implementing Solution.....	22
Conclusion.....	23

Acknowledgement

Thank you to Jim Bryant, President of Bryant Solutions, Inc. who organized the test case and co-authored with Rolland Zhang, Senior Product Manager of Keysight Technologies, Inc.

About Bryant Solutions

Bryant Solutions offers technical training, accredited certifications, and a wide range of solutions and services designed to drive higher Quality of Service and more revenue for our clients in the Telecommunication Industry. The company also designs and develops proprietary systems to augment its training courses in solidifying the learning experience. Our proprietary systems simulate various real world conditions and problems students will encounter on the job.

Since 2002, Bryant Solutions has focused on developing training courses for wireless carriers, tower contractors, local government agencies and the military. In addition, we can develop and present training solutions for companies looking to outsource this service for the systems they sell. We have the technical expertise, educational background, and experience necessary to deliver quality solutions and services. For more information visit www.bryantsolutions.com.



Background on Interference

With the explosive growth of wireless networks, interference between networks has become the center issue that needs to be addressed to ensure the network quality. There are many issues around interference, and intermodulation is the toughest one to deal with.

The following outlines a series of tests which were performed to get to the root cause(s) as to why Wireless Operator antenna sites were interfering with public safety agencies in Alameda County, California. In Alameda County, Wireless Operator uses A', A, and A' bands, and the county is using 21 10 kHz channels ranging from 866.9375 MHz to 868.9250 MHz. The county's closest control channel to Wireless Operator is at 868.7625 MHz. The high power from GSM 850 MHz sites (+47 dBm) was causing several different types of public safety handheld and mobile radios the inability to see the control channel for their network. An initial assessment proved that (in most cases) reducing the GSM radio power to 35 dBm kept the interference at an acceptable level; however, some GSM sectors had to be completely shut down. During our initial field assessment on a site in Newark, California, moving the GSM control channels (BCCHs) to the A'-band allowed Wireless Operator to bring power back to +47 dBm without interfering with public safety. This presented a new potential problem where a Wireless Operator could produce a 5th order intermodulation product and interfere with themselves in their 850 UMTS uplink channel. Also, the A'-band had limited channels which also presented an additional problem considering the number of Wireless Operator sectors that were affected. With public safety aware that a Wireless Operator was interfering with their communications, sectors (or entire GSM sites) were either being shut down, or their power reduced to 35 dBm.

Bryant Solutions was contracted by the Wireless Operator to assist in resolving the interference. With the cooperation of the wireless operator, public safety telecommunications group and Keysight Technologies, Bryant Solutions setup a series of field tests using the Motorola XTS handheld radio to determine the root cause of the interference and how to resolve it. This proactive approach would allow Wireless Operator RF Engineers to ensure future sites in Alameda County do not interfere with public safety.

Goals to Resolve Interference

The first step in the testing process was to come up with a list of potential reasons why the interference is occurring. This is a crucial first step to resolving the problem. We came up with the following list of potential sources:

- Wireless Operator is overpowering (saturating) the input to the public safety's radios.
- Adjacent Wireless Operator channels in the A'-band are interfering with public safety's control channel at 868.7625 MHz.
- Wireless Operator channels are mixing in the County's radios to produce intermodulation products that are on top of public safety's channels.
- Public safety's coverage and signal-to-noise (S/N) levels are borderline and are therefore impacted by any RF from nearby wireless operator sites.

In order to fully understand the impact of these potential sources of interference, we will need to add one additional test. The goal of this fifth test is to define a relationship between the composite power level of a Wireless Operator GSM signal and a public safety control channel when both signals are transmitted at the same center frequency. This information is necessary to understand which intermodulation products pose a problem with public safety. As an example, it may be possible to have a 5th order intermodulation product at 878.7625 MHz (inside the radio) if the composite power is adequately below the composite power level of the county's control channel which is at the same frequency. Things get a little trickier when there is an offset between the center frequency of Wireless Operator's signal and public safety's signal. In these situations, we need to look at where on the GSM the Wireless Operator overlaps with public safety's narrow 10 kHz signal.

As a final step we will need to verify our results in the field on actual problems for two different scenarios. First we will need to look at an area where public safety's power level is high, such as -70 dBm and where it is borderline at around -110 dBm.

Identifying Root Cause(s) of Interference

Public safety allowed the testing to be performed at their facility. The location had strong over-the-air control signals from one of public safety's towers in the area. Figure 1 shows a block diagram of the setup used to perform all the necessary testing.

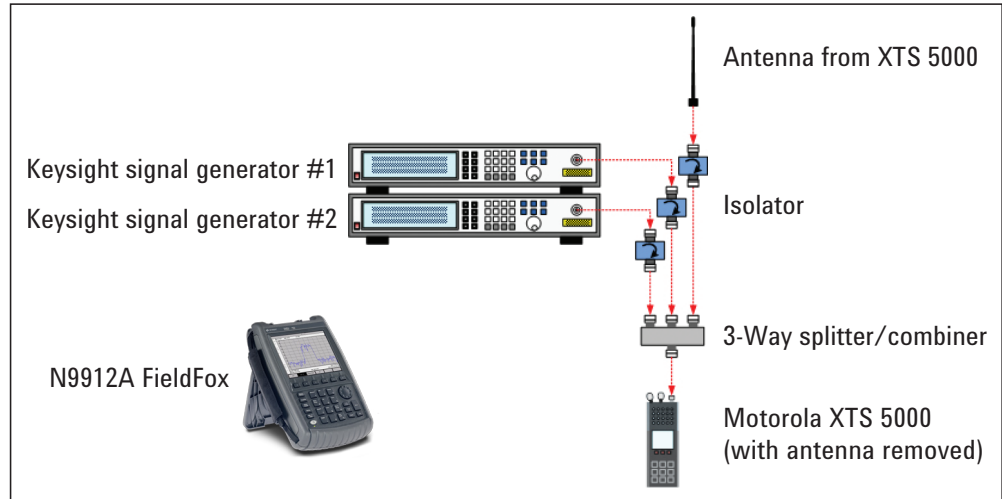

Figure 1. Block diagram of test setup

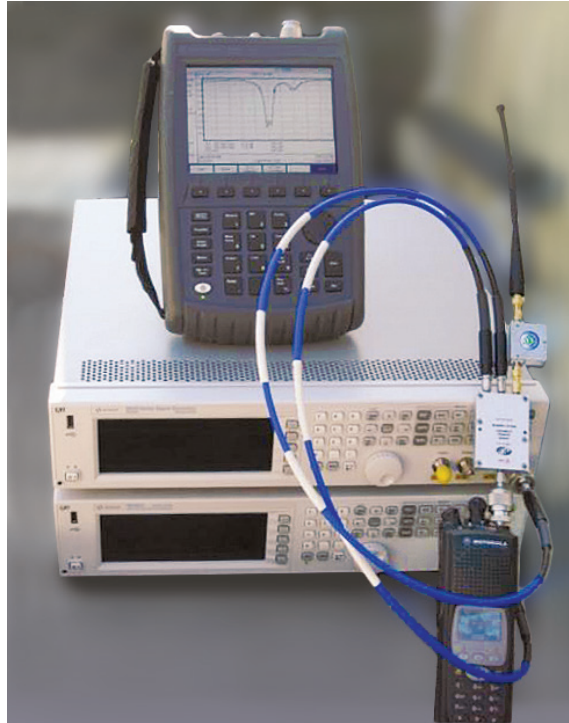

Figure 2. Actual test setup

Identifying Root Cause(s) of Interference (continued)

A 3-way splitter was used to inject up to three signals into a Motorola XTS 5000 radio. The Motorola XTS 5000 is a common radio used by the county and it provided a tone when it could not see a control channel from public safety's RF network. Two of the three ports of the splitter were connected to the signal generators as shown in Figure 1. These signal generators were used to transmit signals at various center frequencies and amplitudes to mimic the interference from Wireless Operator sites. Signal generator #1 was used to transmit GSM signals whereas signal generator #2 generated constant wave (CW) signals. The last port of the splitter was dedicated to injecting public safety's control channel into the radio via the omni antenna from the Motorola radio. As indicated earlier, the isolator was used to prevent over-the-air retransmission of the signals from the signal generators.

Figure 2 shows a picture of the actual test setup. A Keysight Handheld FieldFox is shown on top of the signal generators. This handheld test unit was used for various spectrum analysis and return loss measurements. FieldFox has the capability to make vector network analysis, power meter and spectrum analysis measurements, and is designed for installation and maintenance use. In addition, FieldFox can make network analysis measurements without using a calibration kit, this is very powerful feature for field work.

In general, the front end of a radio is comprised of a duplexer, amplifier, mixer and VCO (voltage controlled oscillator) (see Figure 3). The duplexer plays the role of splitting both the transmit and receive signals, as well as providing pre-selection. Transmitting signals are up-converted from an IF frequency to carrier frequency. On the other hand, receive signals are filtered through the duplexer and LNA, down convert to IF frequency via the mixer, then demodulated to get an audio signal. The channel selection is done in the IF band, so the front end is relatively wide. It is easier to provide channel selectivity on IF frequencies than to design a tunable RF filter in the front end and a wider front end creates its own set of issues.

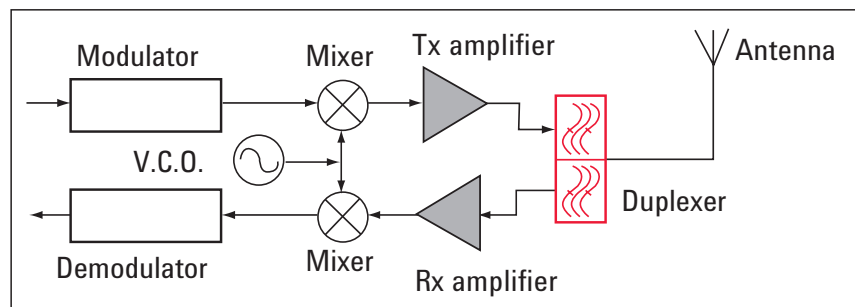

Figure 3. Block diagram of front end of analog radio

Return loss measurement

Before beginning the formal testing, we wanted to evaluate the front end of the Motorola XTS 5000 to see what kind of pre-selection it has. We performed a return loss measurement on the antenna port of the radio under test. Figure 4 shows the return loss of the radio we used for the testing. The measurement shows that the front end of the radio (up to the internal amplifiers) is wide open from 850 to 950 for a return loss of 6 dB. This makes input saturation a real possibility for interference between public safety and carriers with low antenna sites. Given the close proximity of public safety's frequencies to carriers utilizing the A" band, the potential for adjacent channel interference is high regardless of the selectivity of the radio's front end. This is especially true for carriers transmitting GSM at high power levels. Therefore, adjacent channel interference, receiver intermodulation, and blocking are all potential problems that might arise between public safety and low Wireless Operator antenna sites.

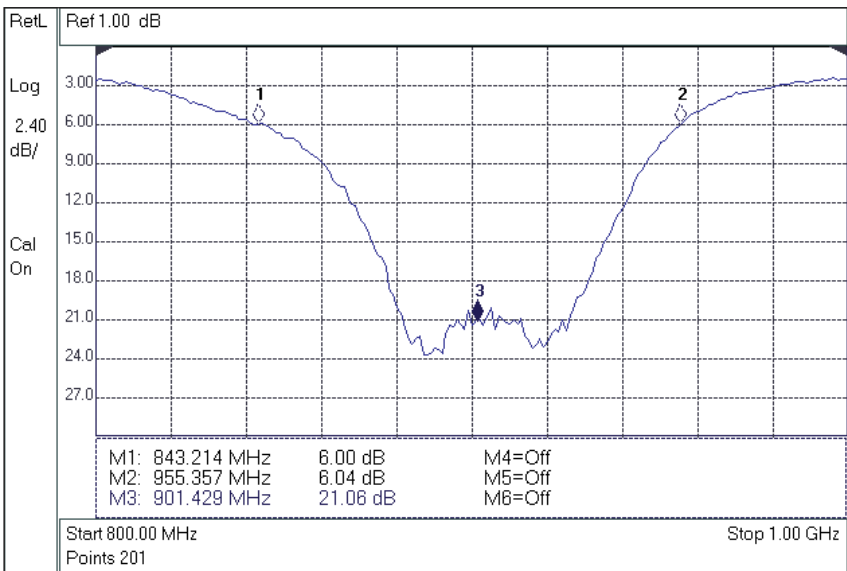

Figure 4. Return loss measurement of front end of radio

Interference vs. public safety control channel power levels

Before testing for input saturation, adjacent channel power interference, and intermodulation, we needed to understand the relationship between the power levels for interference and public safety channels. In order to perform this test, we utilized the test setup shown in Figure 1 using only one signal generator for this test.

With our current setup, the Motorola radio identified the public safety's control channel at 868.7625 MHz. The power level of public safety's control channel at the radio port measured -67 dBm. We injected a CW signal into the Motorola radio on top of public safety's control signal at 868.7625 MHz. We initially set the power level for this CW signal at -100 dBm. Our goal was to increase the CW power level until the public safety radio no longer detected the control channel at 868.7625 MHz. We determined that when the power level for the CW signal exceeded -73 dBm, the public safety radio could not see the control channel. When considering input saturation, adjacent channel power, and intermodulation, Wireless Operator's power levels need to increase to 6 dB below public safety's control channels.

Input saturation

We utilized the test setup in Figure 1 to determine input saturation. We used one signal generator to inject a CW signal into the public safety radio at various frequencies and power levels within public safety's operating band. Our goal was to produce a graph showing the saturation point in 200 kHz increments for the front end of the public safety radio. We were unable to produce this graph out of fear of damaging the front end of the radio. After injecting up to -10 dBm at various frequencies, we were unable to saturate the front end. This provides valuable information. Based on our analysis in the field, the Wireless Operator power levels at problematic sites, does not exceed -10 dBm at the ground level below sites. Therefore, Wireless Operator sites are more than likely not saturating the input to public safety radios. At least we found no proof that this was the source of the interference and complaints. This was probably because the power levels for Wireless Operator were typically at or below -30 dBm at the base of the sites (sectors) in question.

Adjacent channel power

This test again utilized Figure 1 and we used one signal generator. Our next goal was to determine whether the power from an adjacent Wireless Operator channel could be interfering with public safety's adjacent control channel at 868.7625 MHz. Figure 5 shows the potential for interference.

The closest Wireless Operator GSM channel is 128 (869.2 MHz) in the "A" band. GSM channels in this band are hopping frequencies. We felt that there was a good chance adjacent channel interference was not the source of the interference between Wireless Operator and public safety. With channel 127 (at 869.0 MHz) being used as a guard band between Wireless Operator and public safety, there is a slim chance enough power from channel 128 would be spilling over to the closest public safety control channel at 868.7625 MHz. We injected a GSM signal up to -10 dBm on channel 128 and the public safety radio had no problem seeing the control channel at -67 dBm. If the public safety radio has about 70 dB of rejection to its adjacent channel, worst-case the Wireless Operator's power level at the ground level is -10 dBm, and public safety's control channel power level is at -100 dBm, there is still a good chance Wireless Operator will not interfere with public safety. Wireless Operator's power level after rejection will be less than -80 dBm at 869.2 MHz. That portion of the GSM signal at 868.7625 MHz will be non-existent. We found no proof to support adjacent channel power as a source of the interference.

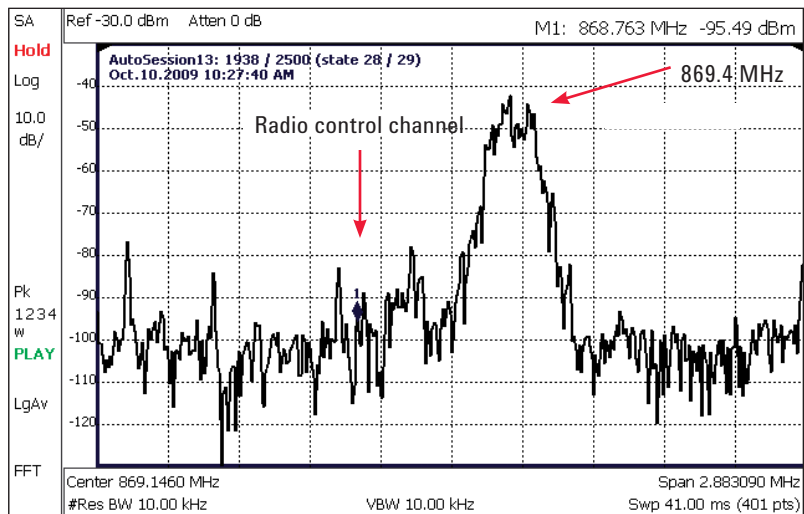

Figure 5. Strong GSM channel 129 next to public safety

Intermodulation

If intermodulation is contributing to the interference, it is due to two or more GSM channels mixing and the products are falling on the public safety control channels. The worst-case scenario would be that one of the fundamental GSM channels is a BCCH. This means that the interference to public safety is constant.

Figure 6 shows the fundamental GSM frequencies F_1 and F_2 and the intermodulation products to the left. When testing for intermodulation we concentrated on the 3rd ($2F_1 - F_2$), 5th ($3F_1 - 2F_2$) and 7th ($4F_1 - 3F_2$) intermodulation products.

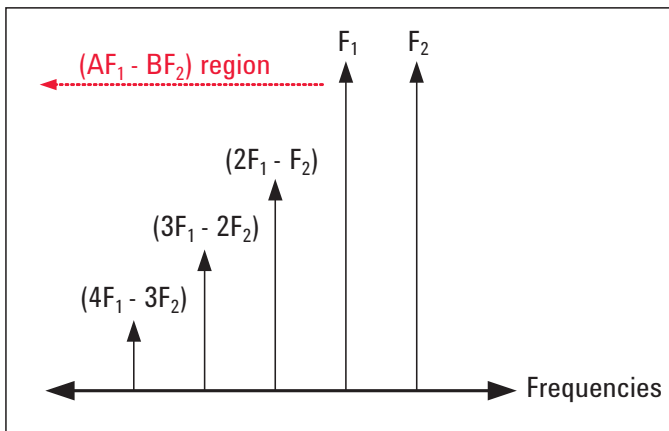

Figure 6. Intermodulation orders potentially affecting public safety

In order to test the theory of intermodulation, we started by defining two fundamentals such that their 3rd order intermodulation product will fall on public safety's control channel at 868.7625 MHz. We randomly selected one of the fundamentals at 871.2 MHz (GSM channel 138). The second fundamental (F_2) could then be defined using the following two equations:

$$\begin{aligned} - 3^{\text{rd}} \text{ Order Intermodulation Product } (2F_1 - F_2) &= 868.7625 \text{ MHz} = 2(871.2 \text{ MHz}) - F_2 \\ - F_2 &= 2(871.2 \text{ MHz}) - 868.7625 \text{ MHz} = 873.6375 \text{ MHz} = \sim 873.6 \text{ MHz} \end{aligned}$$

Now that we have the fundamental frequencies defined, we can now utilize the setup in Figure 1 for testing using both signal generators. The frequency transmitted at 871.2 MHz is a GSM signal and the other higher frequency is a CW signal. While injecting the two fundamentals, we increased the power levels until the control signal at 868.7625 MHz could not be seen by the public safety radio. The power level of the control signal was -67 dBm. When the power level for both fundamentals reached -21 dBm at the input to the radio, it could not see the control signal. Therefore, we concluded that the 3rd order intermodulation products will be approximately 46 dB down from the power level of the fundamentals.

Intermodulation (continued)

Using the information from section 3.2, we can now determine when the 3rd order intermodulation product of two GSM signals will cause interference with public safety. The following equation relates the public safety control channel to intermodulation products:

$$\text{-- 3rd Order products: [Wireless Operator Power (dBm) - 45 dB] } \leq \text{ [Public Safety Control Channel (dBm) - 6 dB]}$$

We now repeated the test above for the 5th order using the equations below:

$$\begin{aligned} \text{-- 5th Order Intermodulation Product } (3F_1 - 2F_2) &= 868.7625 \text{ MHz} = 3(871.2 \text{ MHz}) - 2F_2 \\ \text{-- } F_2 &= \frac{3(871.2 \text{ MHz}) - 868.7625 \text{ MHz}}{2} = 872.41875 \text{ MHz} = \sim 872.4 \text{ MHz} \end{aligned}$$

The power level at the radio was -12 dBm when the radio could not see the public safety control channel at 868.7625 MHz. The power level of the control channel was -67 dBm, so the 5th order intermodulation products are 56 dB down from the power level of the fundamentals.

$$\text{-- 5th Order products: [Wireless Operator Power (dBm) - 55 dB] } \leq \text{ [Public Safety Control Channel (dBm) - 6 dB]}$$

Repeating for the 7th order, we came up with the following:

$$\begin{aligned} \text{-- 7th Order Intermodulation Product } (4F_1 - 3F_2) &= 868.7625 \text{ MHz} = 4(871.2 \text{ MHz}) - 3F_2 \\ \text{-- } F_2 &= \frac{4(871.2 \text{ MHz}) - 868.7625 \text{ MHz}}{3} = 872.0125 \text{ MHz} = \sim 872.0 \text{ MHz} \end{aligned}$$

The power level at the radio was -10 dBm. This is a difference of 57 dB. Therefore the relationship is:

$$\text{-- 7th Order products: [Wireless Operator Power (dBm) - 57 dB] } \leq \text{ [Public Safety Control Channel (dBm) - 6 dB]}$$

At this point we now have solid evidence that the interference between the Wireless Operator and public safety is in part being caused by the mixing of two or more GSM channels, such that their products fall on the public safety channel. In order for these products to interfere with public safety, the power levels must be greater than the level of the control channel minus 5 dB.

Public safety coverage

An important part of our testing included an analysis of public safety's RF coverage in Alameda County. We obtained the information for all of public safety's site information for Alameda County and the Wireless Operator performed an analysis of their coverage as shown in Figure 7 below.

We found that in all cases, Wireless Operator sites were being shut down in the areas where the public safety coverage had the lowest power levels. With Wireless Operator over-the-air power levels at the ground level near its base station between -30 dBm to -10 dBm, it makes sense that all the intermodulation products caused by Wireless Operator GSM channels could present a significant problem for Alameda County.

2-way radio coverage is decided by its sensitivity as shown below:

– **Sensitivity** = Thermal Noise Density (-174 dBm/Hz) + Channel Bandwidth (40.7 dB) + Noise Rise + Noise Figure (3 dB) + SINAD (12 dB)

In an ideal situation, the noise rise is 0 dB, which makes the sensitivity -118.3 dBm as shown:

– **Sensitivity** = -174 dBm/Hz + 40.7 dB + 0 dB + 3 dB + 12 dB = -118.3 dBm

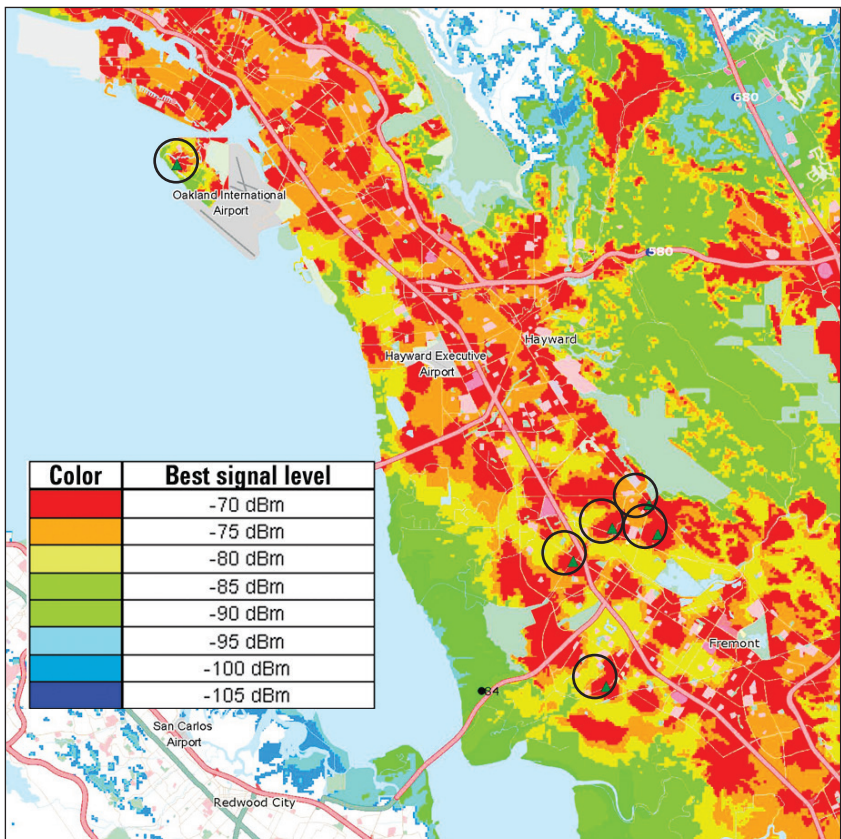

Figure 7. A portion of public safety's RF coverage

Public safety coverage (continued)

In real life situations, the noise rise in the band will not be 0 dB, so the sensitivity will be worse than -118.3 dBm. The measured sensitivity will dictate the maximum allowable path loss. In turn, the path loss will define the RF coverage. Radio coverage should be calculated based on: signal level > -118.3 dBm and a signal-to-noise ratio (S/N) > 12 dB. If public safety radio is at the edge of its coverage area, and close to GSM 850 BTS, it is most likely blocked by nearby GSM 850 downlink signals. Figure 8 illustrates the S/N ratio for public safety in an area where a Wireless Operator GSM sector was shut down due to interference with their control channels. Public safety's RF coverage for this area was borderline, so any RF from low sites (or passing mobiles in vehicles) would create interference.

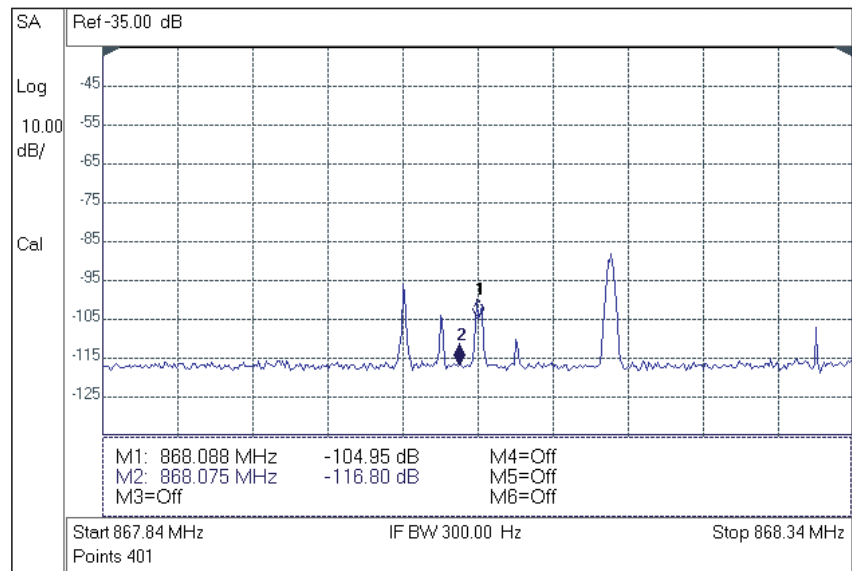

Figure 8. Borderline public safety S/N

Identifying Solution(s) to Resolve Interference

Our initial testing has shown that the cause of the interference between public safety and Wireless Operator GSM sites is more than likely from intermodulation. Proving intermodulation is the source of interference is one step towards a solution; however, we need to prove this in the field on actual sites (sectors) which have either been powered down or completely shut down due to interference with public safety.

To prove our theory, we will need to explain the following:

- How the existing BCCH and hopping channel assignments for these problem sites is creating interference via intermodulation.
- How the existing intermodulation products are related to Wireless Operator's and public safety's power levels.
- Why the new BCCH and/or hopping channel assignments corrects the problem.

Our goal is to change the BCCH and/or the hopping channels for these test sites (sectors) such that the intermodulation products will not interfere with public safety. We also need to bring these test sites back to full power and prove why it worked.

Validating Solution on Wireless Operator Sites

For our field testing, we selected two sites: Site 1 (all 850 sectors) and Site 2.



Figure 9. Site 1

Field scenario #1

Figure 9 shows a picture of Site 1. The antennas are located below the roof line behind the corner extensions on the exterior wall shown on the left top portion of the picture. We chose this site because all 850 GSM sectors had been shut down due to interference with the Newark Police Department.

Validating Solution on Wireless Operator Sites (continued)

Table 1 shows the BCCH and hopping channels for the three 850 sectors. The major concern with these channel assignments is how to show which combinations of these channels are interfering with public safety. The complaint from the Newark Police Department is its inability to see their control channels. Therefore, we will be looking for intermodulation products which fall on or near the following three public safety control channels:

- Channel #1: 866.9375 MHz
- Channel #2: 868.0875 MHz
- Channel #3: 868.7625 MHz

Sector	Channel no.	Frequency (MHz)	Interference	
			Continuous	Intermittent
Site 1X	138 (BCCH)	871.20	867.0 MHz (3 rd)	866.8 MHz(3 rd)
Site 1X	131	869.80	868.0 MHz (3 rd)	867.0 MHz(3 rd)
Site 1X	151	873.80	868.2 MHz (3 rd)	868.0 MHz(3 rd)
Site 1X	237	891.00	867.0 MHz (5 th)	866.8 MHz (5 th)
Site 1X			867.2 MHz (5 th)	868.0 MHz (5 th)
Site 1Y	148 (BCCH)	873.20	868.8 MHz (5 th)	868.2 MHz (5 th)
Site 1Y	134	870.40	869.0 MHz (5 th)	868.6 MHz (5 th)
Site 1Y	154	874.40	867.0 MHz (7 th)	868.0 MHz (7 th)
Site 1Y	233	890.20	867.2 MHz (7 th)	866.6 MHz (9 th)
Site 1Z	145 (BCCH)	872.60	868.0 MHz (7 th)	866.8 MHz (9 th)
Site 1Z	128	869.20	868.4 MHz (7 th)	867.4 MHz (9 th)
Site 1Z	135	870.60	868.8 MHz (7 th)	
Site 1Z	152	874.00	869.0 MHz (7 th)	
			867.0 MHz (9 th)	
			867.2 MHz (9 th)	
			867.8 MHz (9 th)	
			868.2 MHz (9 th)	
			868.4 MHz (9 th)	

Table 1. Site 1 initial channel assignments and intermodulation products

Validating Solution on Wireless Operator Sites (continued)

We will also need to take into account the power levels for the 3rd, 5th, 7th and 9th intermodulation products to ensure power levels are sufficiently below public safety's control channels. We measured a Wireless Operator composite power level as high as -10 dBm at the ground level below the site; whereas, public safety's control channel at 868.0875 MHz measured as low as -75 dBm. Based on these power levels, we found that all products up to at least the 9th order intermodulation will interfere with public safety if the products fall on or near public safety's control channel. Even though we did not perform a test for the 9th order, we approximated that it would be 5 dB lower than the 7th order. Using the equations from section 3.5, we determined all products up to the 9th order should be considered as shown below:

- **3rd Orders:** Wireless Operator Power (-55 dBm) \geq Public Safety Control Channel (-81 dBm).
- **5th Orders:** Wireless Operator Power (-65 dBm) \geq Public Safety Control Channel (-81 dBm).
- **7th Orders:** Wireless Operator Power (-67 dBm) \geq Public Safety Control Channel (-81 dBm).
- **9th Orders:** Wireless Operator Power (-72 dBm) \geq Public Safety Control Channel (-81 dBm).

We created a 14 tone calculator to look at these intermodulation orders. We then tagged those products that fell between 866 MHz and 869 MHz, which are the frequencies used by public safety. We then categorized the products based on whether they were continuous or intermittent. Continuous products are where one of the fundamentals is from a BCCH channel. The continuous products are the most harmful when they interfere with public safety. The intermittent products are comprised of two hopping channels and can be ignored if they do not interfere with public safety control channels.

Validating Solution on Wireless Operator Sites (continued)

Sector	Channel no.	Frequency (MHz)	Interference	
			Continuous	Intermittent
Site 1X	235 (BCCH)	890.60	None	866.8 MHz (3 rd)
Site 1X	131	869.80		867.0 MHz (3 rd)
Site 1X	151	873.80		868.0 MHz (3 rd)
Site 1X	237	891.00		866.8 MHz (5 th)
Site 1X				868.0 MHz (5 th)
Site 1Y	239 (BCCH)	891.40		868.2 MHz (5 th)
Site 1Y	134	870.40		868.6 MHz (5 th)
Site 1Y	154	874.40		868.0 MHz (7 th)
Site 1Y	233	890.20		866.6 MHz (9 th)
Site 1Y				866.8 MHz (9 th)
Site 1Y				867.4 MHz (9 th)
Site 1Z	237 (BCCH)	891.00		
Site 1Z	128	869.20		
Site 1Z	135	870.60		
Site 1Z	152	874.00		

Table 2. Site 1 new channel assignments and intermodulation products

Table 2 shows where public safety's control channel #2 will present a problem for continuous interference. When public safety is not using this channel there is less chance of interference. By changing the BCCH for each sector to a channel from the A" band, we are able to remove the continuous interference. As you can see from the table, there is still a potential for intermittent interference; however, the probability of this is much lower. It is also something public safety is willing to deal with.

We made some assumptions when performing the field testing. Most importantly, we defined the power levels for all three sectors as one value for a given location below a site. We did this for a couple of reasons: 1. to simplify the resolution process, 2. because of the fluctuation in power levels on the ground. GSM 850 has been at 47 dBm (full power) for over a month without any complaints from the Newark Police Department.

Field scenario #2

Figure 10 shows a picture of Site 2. This site is located at a fire department in Alameda. The GSM 850 antennas for this site are at the lowest position on the monopole tower. There are two sectors which were completely powered down due to interference complaints from the fire department. They're complaint was that they were unable to see their control channels.



Figure 10. Site 2

We chose this site because it was a high traffic site and had a lot of customer complaints. Our goal with this site was the same as Site 1; we wanted to minimize the number of constant interferences. In order to reduce or remove the constant interferences, we needed to change the BCCH channel assignments. When we resolved the interference at Site 1, we utilized the A' band; however, there were a limited number of GSM channels in this band. Therefore, we wanted to use BCCH channels in the A band to resolve the interference at this site.

Our first step was to analyze the current site channels to determine why the site was interfering with public safety. Table 3 below shows the continuous and intermittent intermodulation products produced by the site between 866 MHz and 869 MHz. The last two frequencies in the continuous column are potential interferers. The 7th order at 869 MHz will present a problem for public safety control channels #2 and #3 at 868.0875 MHz and 868.7625 MHz respectively. The span for this product will be close to 1 MHz so it could easily be a problem as long as the power level is high enough. The 9th order at 868 MHz could interfere with the same channels. The span of the 9th order product would be around 1.25 MHz.

Field scenario #2 (continued)

Sector	Channel No.	Frequency (MHz)	Interference	
			Continuous	Intermittent
Site 2X	142 (BCCH)	872.00 MHz	867.2 MHz (5 th) 868.8 MHz (7 th) 869.0 MHz (7 th) 867.4 MHz (9 th) 868.0 MHz (9 th)	None
Site 2X	154	874.40 MHz		
Site 2X	233	890.20 MHz		
Site 2X	239	891.40 MHz		
Site 2Y	147 (BCCH)	873.00 MHz		
Site 2Y	134	870.40 MHz		
Site 2Y	180	879.60 MHz		
Site 2Y	235	890.60 MHz		

Table 3. Site 2 initial channel assignments and intermodulation products

The Wireless Operator power level at ground level below the tower was as high as -10 dBm and the public safety control channel power level was as low as -88 dBm. Utilizing the equations in the Intermodulation section on page 11, we found that all products up to the 9th order could produce interference with public safety.

- **3rd Orders:** Wireless Operator Power (-55 dBm) ≥ Public Safety Control Channel (-94 dBm).
- **5th Orders:** Wireless Operator Power (-65 dBm) ≥ Public Safety Control Channel (-94 dBm).
- **7th Orders:** Wireless Operator Power (-67 dBm) ≥ Public Safety Control Channel (-94 dBm).
- **9th Orders:** Wireless Operator Power (-72 dBm) ≥ Public Safety Control Channel (-94 dBm).

Sector	Channel No.	Frequency (MHz)	Interference	
			Continuous	Intermittent
Site 2X	142 (BCCH)	872.00 MHz	867.2 MHz (5 th)	None
Site 2X	154	874.40 MHz		
Site 2X	233	890.20 MHz		
Site 2X	239	891.40 MHz		
Site 2Y	144 (BCCH)	872.40 MHz		
Site 2Y	134	870.40 MHz		
Site 2Y	180	879.60 MHz		
Site 2Y	235	890.60 MHz		

Table 4. Site 2 new channel assignments and intermodulation products

Table 4 shows the solution. We only had to change the BCCH for the Y-sector to remove the interference. This GSM 850 site is now back to full power with no further complaints from public safety. The solution for these sites illustrates that the A' band does not need to be used to resolve the interference.

Implementing Solution

Special care should be taken when implementing sites in areas where public safety utilizes adjacent frequencies. Considerations include the following:

- Antenna height above ground
- Worst-case (highest) GSM power level at the ground level
- Worst-case (lowest) public safety power level at ground level

In the event that sites and interference with public safety already exists, then analyze the channels to understand why. Then change one or more BCCH channels to remove all or most of the continuous intermodulation.

Conclusion

A carrier with GSM 850 sites was creating interference with public safety's control channels. Public safety was using frequencies adjacent to the carrier. Interference was typically found to be from low sites (high power level at ground level). We performed tests on a public safety radio to determine if this interference was caused by input saturation, adjacent channel interference, intermodulation, or poor public safety coverage. We determined that GSM channels were mixing in the public safety radio to produce intermodulation products which fell on top of public safety control channels. This prevented public safety from using their radios for communication.

In addition, we were able to demonstrate that we could prevent the interference by changing the GSM channels such that their product did not fall on public safety control channels. To simplify the solution process, we developed a 14 tone calculation to accomplish the following:

- Understand how the current GSM channel assignments at a site are causing the interference.
- Change the channel assignments such that intermodulation products do not interfere with public safety control channels.

Lastly, we identified a relationship between public safety's power and the carrier's power at the ground level. We also determined the relative power of the intermodulation order from the fundamental. Therefore, we can conclude when an intermodulation will create a problem. Moving forward, it is important to take these considerations into account when designing new sites in areas where public safety utilizes adjacent frequencies.

myKeysight

myKeysight

www.keysight.com/find/mykeysight

A personalized view into the information most relevant to you.



www.axiestandard.org

AdvancedTCA® Extensions for Instrumentation and Test (AXIe) is an open standard that extends the AdvancedTCA for general purpose and semiconductor test. Keysight is a founding member of the AXIe consortium. ATCA®, AdvancedTCA®, and the ATCA logo are registered US trademarks of the PCI Industrial Computer Manufacturers Group.



www.lxistandard.org

LAN eXtensions for Instruments puts the power of Ethernet and the Web inside your test systems. Keysight is a founding member of the LXI consortium.



www.pxisa.org

PCI eXtensions for Instrumentation (PXI) modular instrumentation delivers a rugged, PC-based high-performance measurement and automation system.



Three-Year Warranty

www.keysight.com/find/ThreeYearWarranty

Keysight's commitment to superior product quality and lower total cost of ownership. The only test and measurement company with three-year warranty standard on all instruments, worldwide.



Keysight Assurance Plans

www.keysight.com/find/AssurancePlans

Up to five years of protection and no budgetary surprises to ensure your instruments are operating to specification so you can rely on accurate measurements.



www.keysight.com/go/quality

Keysight Technologies, Inc.
DEKRA Certified ISO 9001:2008
Quality Management System

Keysight Channel Partners

www.keysight.com/find/channelpartners

Get the best of both worlds: Keysight's measurement expertise and product breadth, combined with channel partner convenience.

For more information about Bryant Solutions, visit www.bryantsolutions.com.

www.keysight.com/find/fieldfox

For more information on Keysight Technologies' products, applications or services, please contact your local Keysight office. The complete list is available at: www.keysight.com/find/contactus

Americas

Canada	(877) 894 4414
Brazil	55 11 3351 7010
Mexico	001 800 254 2440
United States	(800) 829 4444

Asia Pacific

Australia	1 800 629 485
China	800 810 0189
Hong Kong	800 938 693
India	1 800 112 929
Japan	0120 (421) 345
Korea	080 769 0800
Malaysia	1 800 888 848
Singapore	1 800 375 8100
Taiwan	0800 047 866
Other AP Countries	(65) 6375 8100

Europe & Middle East

Austria	0800 001122
Belgium	0800 58580
Finland	0800 523252
France	0805 980333
Germany	0800 6270999
Ireland	1800 832700
Israel	1 809 343051
Italy	800 599100
Luxembourg	+32 800 58580
Netherlands	0800 0233200
Russia	8800 5009286
Spain	0800 000154
Sweden	0200 882255
Switzerland	0800 805353
	Opt. 1 (DE)
	Opt. 2 (FR)
	Opt. 3 (IT)
United Kingdom	0800 0260637

For other unlisted countries:
www.keysight.com/find/contactus
(BP-07-10-14)

