

PZ2100 series High Channel Density Precision Source/Measure Unit Solution

1U Mainframe with 4 slots and 5 SMU modules

Introduction

The Keysight PZ2100 series is the best-in-industry automated test equipment (ATE) solution that uncompromisingly and densely integrates enormous source/measure unit (SMU) resources into valuable rack space with flexible module options. It provides flexible scalability with multiple SMU module options covering a wide range of applications, from conventional static DC measurements down to 10 fA to emerging dynamic/pulsed measurements up to 15 MSa/s and down to 10 μ s width. Uncompromisingly high-density integration that makes full use of available rack space, slots, or SMU module capabilities enables a lower cost per channel as well as 20x smaller rack space than conventional SMUs, thereby significantly reducing your test costs and saving valuable rack space.

This guide provides step-by-step instructions to help you configure to meet the desired test requirements.

Table 1. Steps to configure the PZ2100 series

Step	Selection
1	Add PZ2100 mainframe
2	Select the types and number of SMUs <ul style="list-style-type: none"> • PZ2110A Precision Source/Measure Unit, 1.25 MSa/s, 10 fA, 210 V, 315 mA DC/pulse • PZ2120A Precision Source/Measure Unit, 1 MSa/s, 100 fA, 60 V, 3.5 A DC/10.5 A pulse • PZ2121A Precision Source/Measure Unit, 15 MSa/s, 100 fA, 60 V, 3.5 A DC/10.5 A pulse • PZ2130A 5-Channel Precision Source/Measure Unit, 100 pA, 30 V, 500 mA DC • PZ2131A 5-Channel Precision Source/Measure Unit, 500 kSa/s, 10 pA, 30V, 500 mA DC/pulse
3	Select accessories (optional)
4	Select software license (optional)
5	Select calibration plan (optional)

Configuring your Keysight PZ2100 series

Step 1. Add the PZ2100 mainframe

The PZ2100 mainframe is one model with no other option. Table 2 shows the furnished items of a PZ2100 mainframe.

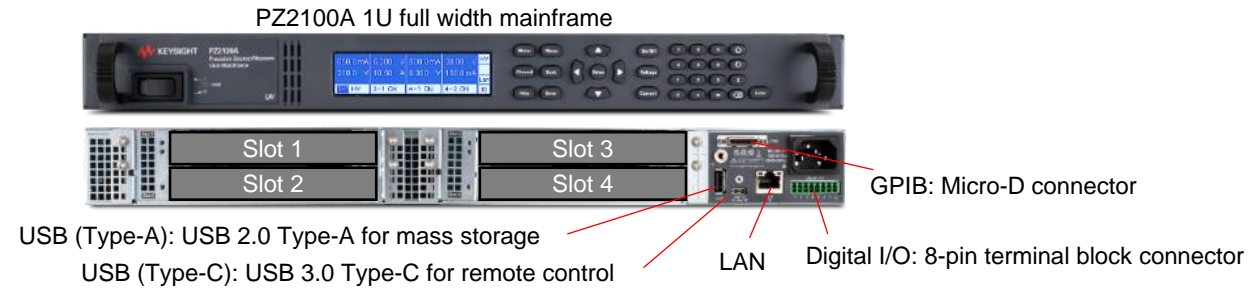



Figure 1. Front view and rear view of PZ2100A mainframe

Table 2. Furnished items of a PZ2100A mainframe

Description	Qty.	Additional information
Certificate of Calibration (without test data)	1	Certificate of calibration (without actual test data). If you need the test data, please specify option UK6.
Quick Reference	1	Printed quick reference (English)
Quick Startup Poster	1	Printed quick startup poster (English)
Connector-terminal block	1	Terminal block for Digital I/O connection
		
Filler panels	4	Installed in PZ2100A
Slot blockers	2	Installed in Slots 2 and 4 of PZ2100A

Step 2. Select the types and number of SMUs

Keysight PZ2100A precision SMU mainframe has 4 slots and allows any mixed module configuration for flexible scalability. Table 3 shows the key specification of the available five SMUs. Choose at least one of the SMUs.

Table 3. Key specifications of each SMU

Product number	Description	Required slot	Num of channels	Max. voltage/ current	Min. resolution	Digitizer mode	Min. pulse
PZ2110A	High-resolution SMU	2	1	210 V/ 315 mA	0.5 μ V/10 fA	1.25 MSa/s	20 μ s
PZ2120A	High-speed SMU	1	1	60 V/ 3.5 A DC, 10.5 A pulse	6 μ V/100 fA	1 MSa/s	50 μ s
PZ2121A						15 MSa/s	10 μ s
PZ2130A	High channel density SMU	1	5	30 V/ 500 mA	6 μ V/100 pA	N/A	N/A
PZ2131A						500 kSa/s	100 μ s

The PZ2110A/20A/21A/30A/31A comes with the following:

Table 4. Furnished items of a PZ2110A/20A/21A/30A/31A



Description	Qty.	Additional information
Certificate of Calibration (without test data)	1	Certificate of calibration (without actual test data). If you need the test data, please specify option UK6.
Quick Reference	1	Printed quick reference (English)
Quick Startup Poster	1	Printed quick startup poster (English)
Connector-terminal block	1	Terminal block for Digital I/O connection: 6-pin for PZ2110/20A/21A 5-pin for PZ2130A/31A
		
Short bar	1	Attached with the SMU

Step 3. Select accessories (optional)

Step 3-1. Select accessories for remote control

The GPIB, USB, and LAN interfaces are available to control the PZ2100A remotely.

Table 5. Accessories for remote control

Connection	PZ2100A mainframe connector	Product number	Description
GPIB	micro-D	PX0110A	Micro Dsub GPIB cable adapter for PZ2100A, 0.25 m 
		PX0114A	Micro Dsub GPIB cable for PZ2100A, 1 m 
<p>Note: Other micro-D to GPIB cables may not be compatible with the PZ2100A. Interoperability cannot be guaranteed with other similar micro-D to GPIB cables because there is no industry standard for a micro-D connector for GPIB.</p>			
USB	USB 3.0 Type-C	Please prepare a commercially available cable.	
LAN	LAN RJ-45 connector, supports 10Base-T, 100Base-T, and 1000Base-T	Please prepare a commercially available cable.	

Step 3-2. Select accessories for rack mount

Select a PX0113A to install a PZ2100A mainframe into a rack. You cannot use support rails for rack mounting your instrument. Support rails would block the airflow needed for cooling.

Table 6. Accessories for rack mount

Product number	Description
PX0113A	Rack mount kit for PZ2100A 

Step 3-3. Decide how to connect the SMU to your DUT interface

All PZ2100A series SMUs have High force, Low force, High sense, Low sense, and Guard. It supports both two-wire and four-wire measurements and low current measurements with a guard. Select the appropriate accessories according to your connection type.

Two-wire connection or four-wire connection

If you are measuring very small resistances or applying a very large current, you should use the four-wire measurement method (also known as the Kelvin method). This technique uses both force and sense terminals. Performing the measurement through the sense terminals (in which no current is flowing) eliminates the undesirable effects of cable resistance.

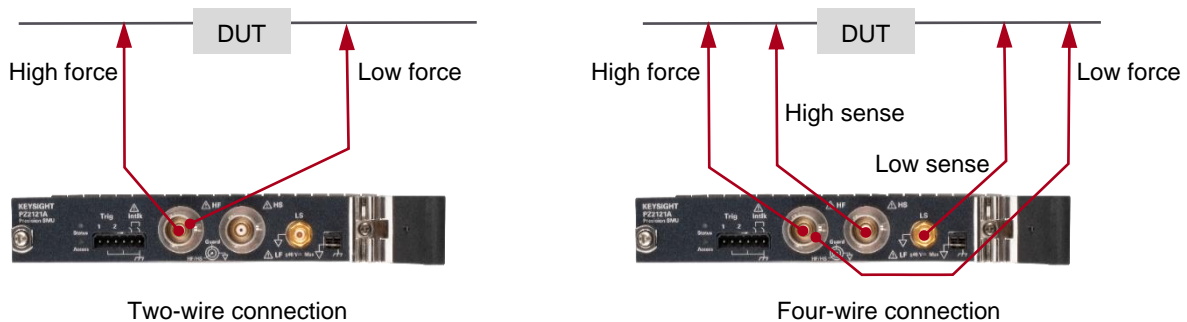

Figure 2. Two-wire connection and four-wire connection configuration

Guarding connections

Low current measurements ($< 1 \text{ nA}$) require guarding to prevent leakage through the measurement cable. Figure 3 illustrates a simplified overview of the guarding technique. Guarded measurements require the use of triaxial cables. A follower ($\times 1$) buffer amplifier maintains the same potential between the guard conductor and the center conductor. Since there is no voltage difference, there is no current from the center conductor to the guard.

Note: in this example, the device interface also has a guarded shield to prevent leakage at the device interface.

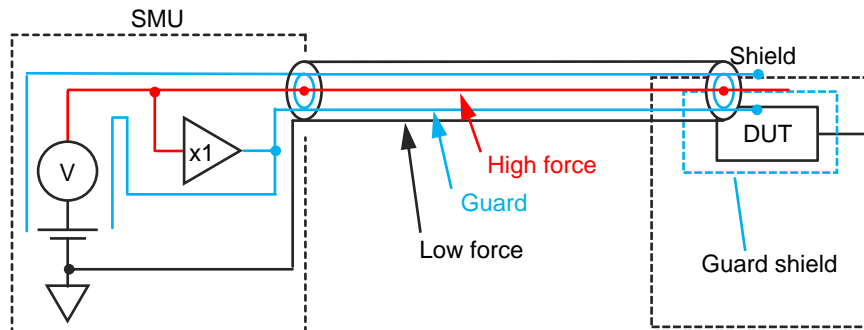

Figure 3. Guarding technique

Low force connection

The low terminals of the PZ2100 series SMU are a floating configuration, enabling you to connect them to any potential up to ± 40 V. If your DUT interface is floating and you need to make the low terminals grounded, you may do so by attaching a short bar, as shown in Figure 4. The PZ2100 series SMU ships with the short bar attached.

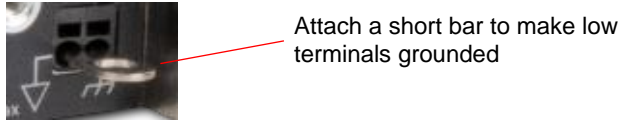

Figure 4. A short bar makes the low terminals grounded

Step 3-4. Select accessories for output terminals of PZ2110A high-resolution SMUs

As shown in Figure 5, PZ2110A has two triaxial terminals for High force and High sense, one SMB terminal for Low sense, and a 6-pin terminal block for the module triggers and interlock.

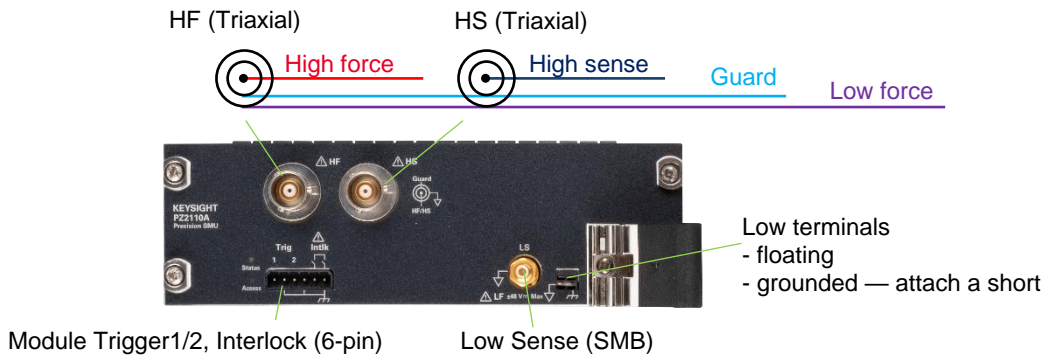
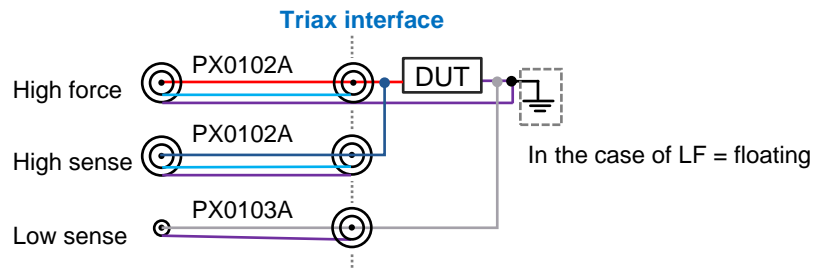

Figure 5. Module panel of PZ2110A high-resolution SMU

Select the necessary cables according to your application requirements, as shown in Table 7.

Table 7. Accessories for PZ2110A high-resolution SMU

Connection	Product number	Description	Qty.	Additional information
Four-wire	PX0102A-001/002	Low noise triaxial cable, 1.5 m/3.0 m	2	Triaxial cable for high force, high sense
	PX0103A-001/002	Triaxial to SMB cable, 1.5 m/3.0 m	1	Convert low-sense terminal from SMB to triaxial



Two-wire	PX0101A-001/002	Low noise triaxial cable, 1.5 m/3.0 m	1	Triaxial cable for high force
----------	-----------------	---------------------------------------	---	-------------------------------

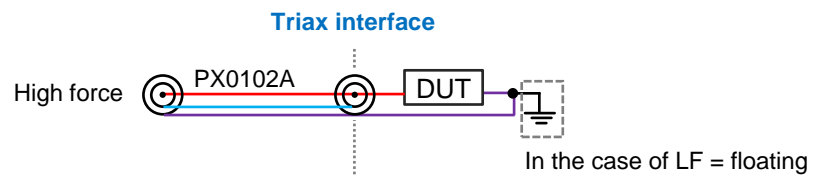

Step 3-5. Select accessories for output terminals of PZ2120A/21A high-speed SMUs

As shown in Figure 6, PZ2120A/21A has two triaxial terminals for High force and High sense, one SMB terminal for Low sense, and a 6-pin terminal block for the module triggers and interlock.

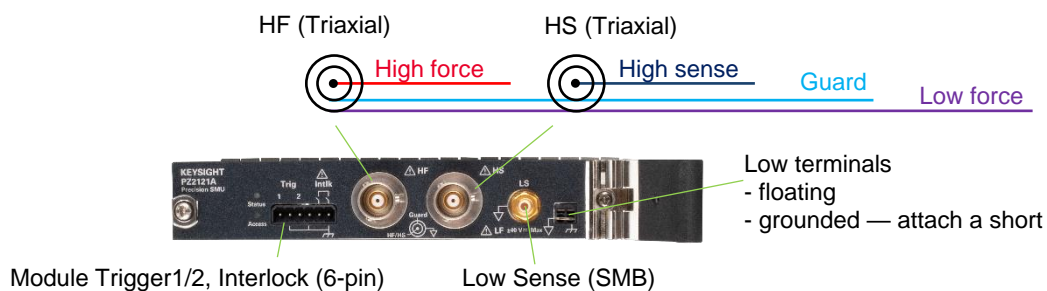
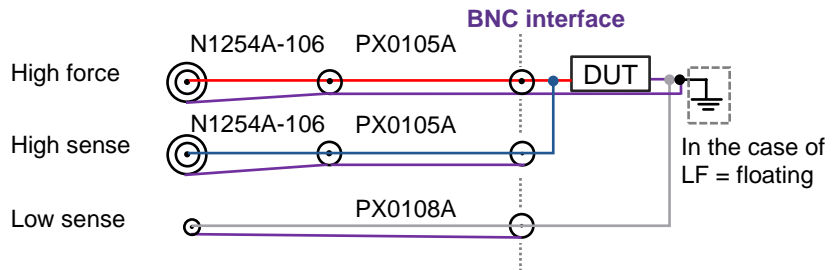

Figure 6. Module panel of PZ2120A/21A high-speed SMU

It's important to select cables with less inductance when applying pulses with a width of approximately 50 μ s or less and a peak of approximately 100 mA or more because cable inductance is critical when applying a clean and narrow current pulse. Keysight provides special low-inductance cables, PX0105A. For other cases, Keysight provides special high current triaxial cables, PX0104A. Select the necessary cables according to your application requirements, as shown in Table 8.

Table 8. Accessories for PZ2120A/21A high-speed SMU

Pulse	Connection	Product number	Description	Qty.	Additional information
Width \leq 50 μ s, and Peak \geq 100 mA	Four-wire	N1254A-106	Triaxial(m) to BNC(f) adaptor	2	Used with PX0105A
		PX0105A-001/002	Low inductance BNC cable 1.5 m/ 3 m	2	For high force, high sense
		PX0108A-001/002	BNC-to-SMB cable, 1.5 m/ 3 m	1	For low sense



> 50 μ s or DC	Four-wire	PX0104A-001/002	High current triaxial cable, 4 A 1.5 m/ 3 m	2	For high force, high sense
		PX0103A-001/002	Triaxial to SMB cable 1.5 m/ 3 m	2	For low sense

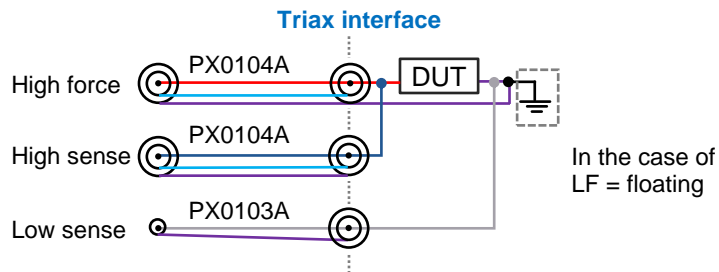

Two-wire	PX0104A-001/002	High current triaxial cable, 4 A 1.5 m/ 3 m	1	For high force
----------	-----------------	--	---	----------------

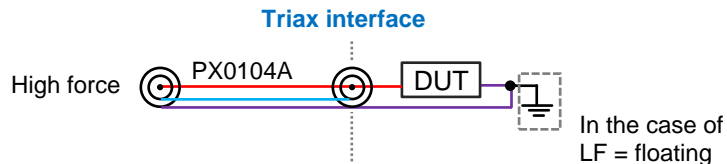

Step 3-6. Select accessories for output terminals of PZ2130A/31A high channel density SMU

As shown in Figure 7, the PZ2120A/21A has a D-sub 25-pin connector. It provides High force (HF), Low force (LF), High sense (HS), Low sense (LS), and Guard (G) terminals for 5 channels. Each channel supports both two-wire and four-wire measurements and low current measurements with a guard. Note that although LF is shared by all channels, it is recommended to use each HF terminal with the LF terminal of the same channel.

For two-wire and no guard connection, select the necessary adapter and cables, as shown in Table 9. The PX0106A adapter is standard; however, a low-noise filter adapter, the PX0107A, is also available for noise-sensitive applications such as quantum computers.

For other connections, you need to develop custom cables to fit your measurement needs. Refer to Tips for making custom cables for PZ2130A/31A.

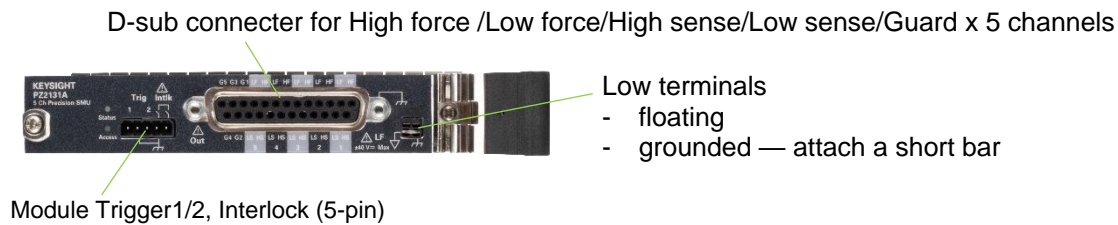
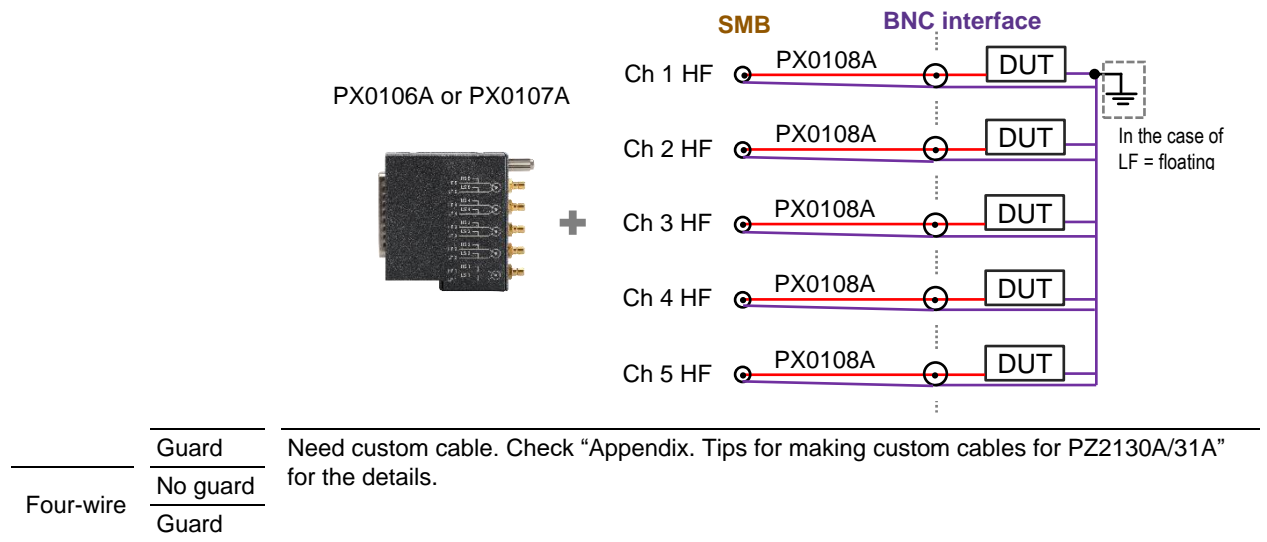

Figure 7. Module panel of PZ2130A/31A high channel density SMU

Table 9. Accessories for PZ2130A/31A high channel density SMU

Connection				Product number	Description	Qty.
Two-wire	No guard	D-sub adapter	Standard	PX0106A	Dsub25-to-5 SMB adapter	1
			Low noise	PX0107A	Low noise filter adapter	
		Cable		PX0108A-001/002	BNC to SMB cable, 1.5 m/3.0 m	5



Step 3-7. Select accessories for trigger

As shown in Figure 8, the PZ2100A has internal trigger lines that enable synchronization among the channels at less than 50 ns accuracy without any cabling. In addition, the mainframe and each SMU have external trigger ports that allow synchronizing with any external equipment flexibly and accurately.

The PZ2100A mainframe has Digital I/O terminals, and you can set Pin 1–7 as the mainframe's external trigger input or output. Note that you can also set these 7 pins as Digital I/O, Digital inputs, high voltage status output, or interlock (Pin 7 only).

Each SMU has 2 x external trigger input or output.

Select the connector terminal and cables according to your application requirements, as shown in Table 10.

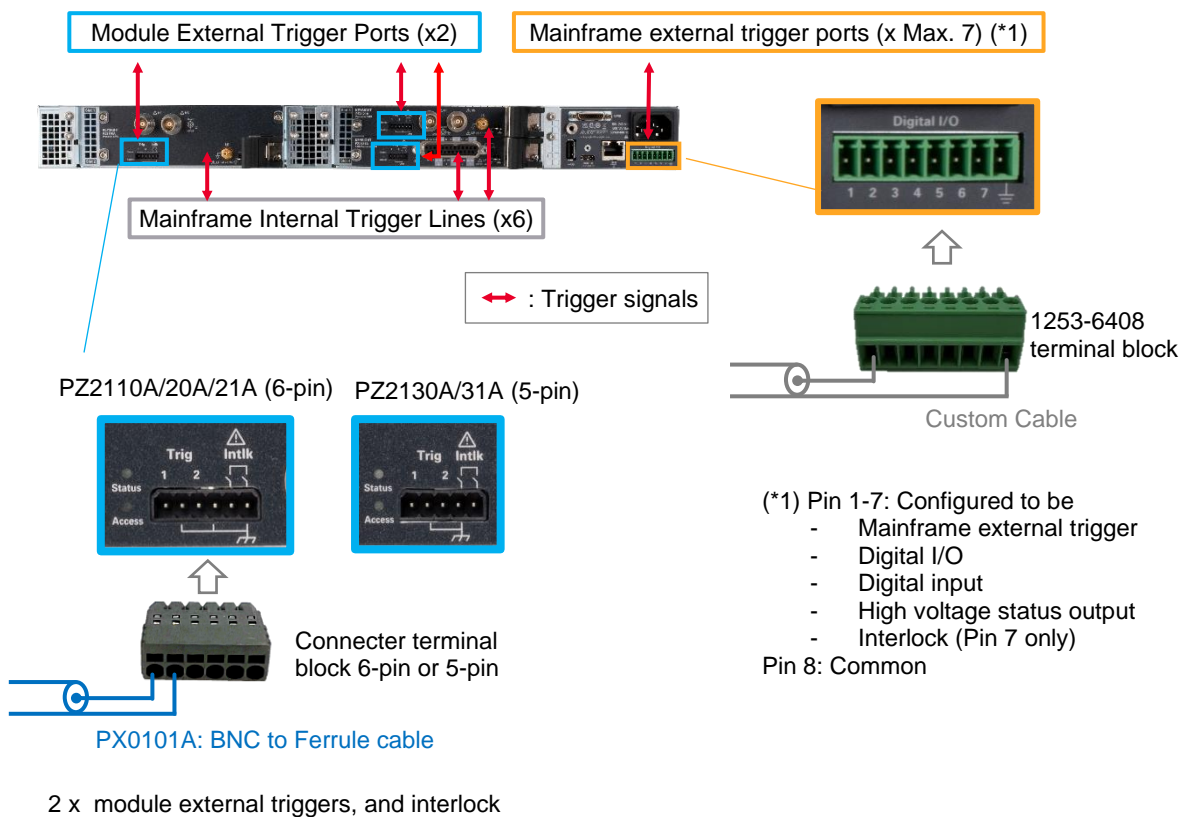

Figure 8. Trigger terminals on mainframe and SMUs

Step 3-8. Select accessories for interlock

The PZ2100 mainframe and each SMU have interlock terminals ports to protect against exposure to voltages above a user-specified value. You can engage the safety lock using interlock pins, and normally, these pins are routed to a shielding box or test fixture that must be closed to complete the interlock circuit. Please refer to the Keysight PZ2100A User’s Guide for more detailed information.

Select the connector terminal and cables according to your application requirements, as shown in Table 10.

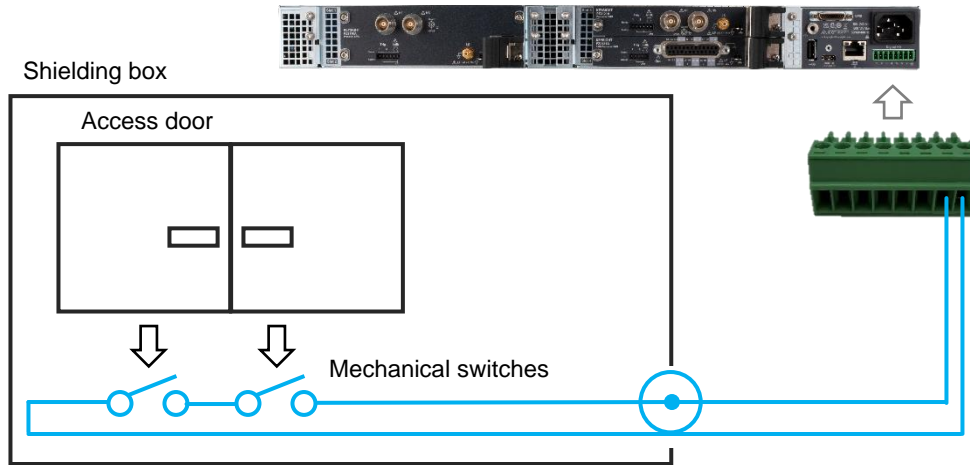





Figure 9. An example of a mainframe interlock circuit installation

Table 10. Accessories for mainframe Digital I/O terminals and SMU trigger/interlock terminals









		Product number	Description	Additional information
Mainframe	Terminal Block	1253-6408	Connector-terminal block 	A PZ2100A mainframe includes a terminal block. Please add it if you need spares.
	Cable	Need custom cable		
Module	Terminal block for PZ2110A/20A/21A	M9601-87002	Connector-terminal block 2.5 mm 6-terminal (includes 5 qty.) 	A PZ2110A/PZ2120A/PZ2121A includes one terminal block. Please add it if you need spares.
	Terminal block for PZ2130A/31A	M9615-87001	Connector-terminal block 2.5 mm 5-terminal (includes 5 qty.) 	A PZ2130A/PZ231A includes one terminal block. Please add it if you need spares.
	Cable	PX0101A-001/002	BNC-to-ferrule terminal cable, 1.5 m/3.0 m	

Step 3-9. Select additional accessories

Select additional accessories according to your application requirements.

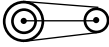
Table 11. Other accessories

Product number	Description	Additional information
PX0101A-001/002	BNC-to-ferrule terminal cable, 1.5 m/3.0 m, VOLT: DC 3.3V	
PX0102A-001/002	Low Noise Triaxial Cable, 1.5 m/3.0 m	
PX0103A-001/002	Triaxial to SMB Cable, 1.5 m/3.0 m, VOLT:DC 210V	
PX0104A-001/002	High Current Triaxial Cable, 4 A, 1.5m/ 3.0 m, VOLT: DC 60V	
PX0105A-001/002	Low Inductance BNC Cable, 1.5 m/3.0 m, VOLT: DC 60V	
PX0106A	Dsub25 to 5 SMB Adapter	
PX0107A	Low Noise Filter Adapter	
PX0108A-001/002	BNC to SMB Cable, 1.5 m/3.0 m, VOLT: DC 60V	
PX0110A	Micro Dsub GPIB Cable Adapter For PZ2100A, 0.25m	
PX0111A	Slot blocker for PZ2100A, qty 2	A PZ2100A mainframe includes them. Please add it if you need spares. 

Product number	Description	Additional information
PX0112A	Filler panel kit for PZ2100A, qty 4	A PZ2100A mainframe includes them. Please add it if you need spares. 
PX0103A	Rack Mount Kit For PZ2100A	
PX0114A	Micro Dsub GPIB Cable For PZ2100A, 1m	
1253-6408	Connector-terminal block	A PZ2100A mainframe includes a terminal block. Please add it if you need spares. 
N1254A-104	Triaxial(f) to BNC(m) adaptor	
N1254A-106	Triaxial(m) to BNC(f) adaptor	
M9601-87001	Short bar to connect low terminals to chassis common (includes 5 qty.)	A SMU includes one short bar. Please add it if you need spares. 
M9601-87002	Connector-terminal block 2.5 mm 6-terminal (includes 5 qty.)	A PZ2110A/PZ2120A/PZ2121A includes one terminal block. Please add it if you need spares. 
M9615-87001	Connector-terminal block 2.5 mm 5-terminal (includes 5 qty.)	A PZ2130A/PZ2131A includes one terminal block. Please add it if you need additional spares. 

Step 4. Select software license (Optional)

PathWave IV curve software

The Keysight PathWave IV curve software has powerful measurement capabilities to control the PZ2100 series SMUs. It supports a variety of functions such as a sweep measurement, a sampling measurement, graphical display functions, and the ability to save test results into CSV files, which makes it easy to quickly set up and perform IV measurements and to display the measurement data in tables and graphs without the need to program. It supports various license types. Please select the one that is appropriate for you.

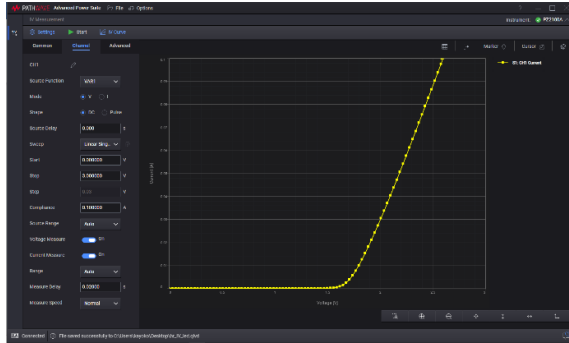

Step 1. Choose your software product, PW9251A.

Step 2. Choose your license term: subscription.

Step 3. Choose your license type: node-locked, transportable, USB portable, or floating

Step 4. Choose your support subscription duration.

License terms

- Subscription – Subscription licenses can be used through the term of the license only (6, 12, 24, or 36 months).

License types

- Node-locked – License can be used on one specified instrument/computer.
- Transportable – License can be used on one instrument/computer at a time but may be transferred to another using Keysight Software Manager (internet connection required).
- USB portable – License can be used on one instrument/computer at a time but may be transferred to another using a certified USB dongle (available for additional purchase with Keysight part number E8900-D10).
- Floating (single site) – Networked instruments/computers can access a license from a server one at a time. Multiple licenses can be purchased for concurrent usage.

KeysightCare software support subscriptions

Subscription licenses include a software support subscription through the term of the license

Step 5. Select a calibration plan (Optional)

Factory calibration and certification of calibration come as standard. The optional ISO 17025 (not accredited), ANSI Z540, and commercial calibration certificate with test data are available as follows:

Table 13. The available calibration plans

Module Options	Description	Additional information
1A7	Calibration + uncertainties + guard banding (not accredited)	Calibration certificate with measurement results available only at the time of purchase
A6J	ANSI Z540-1-1994 calibration	Calibration certificate with measurement results available only at the time of purchase
UK6	Commercial calibration certificate with test data	Calibration certificate with measurement results available only at the time of purchase

Appendix. Tips for making custom cables for PZ2130A/31A

For connection of PZ2130A/31A, The PX0106A Dsub25-to-5 SMB adapter and the PX0108A BNC-to-SMB cable is available for a two-wire, non-guarded connection. For other connections, such as the following configuration, you need to develop custom cables to fit your measurement needs.

- Four-wire, guarded connection
- Four-wire, non-guarded connection
- Two-wire, guarded connection

These are common tips for all connections:

- Although LF is shared by all channels, it is recommended to use each HF terminal with the LF terminal of the same channel.
- The simpler two-wire configuration uses only the force terminals. In two-wire mode, the sense terminals remain open.
- Never connect the guard shield to any output, including the frame/chassis ground or any other guard terminal.

Four-wire, guarded connection

- Shield HF and HS by G to reduce the leakage current between the instrument and a DUT.
- Shield G by LF, because G can be over 42 V when LF is floating
- Shield LS by LF to avoid the external noise influence.

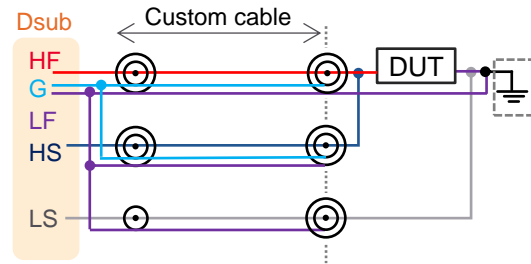

Four-wire, non-guarded connection

- Shield HF, HS, LS by LF to avoid any external noise influence.

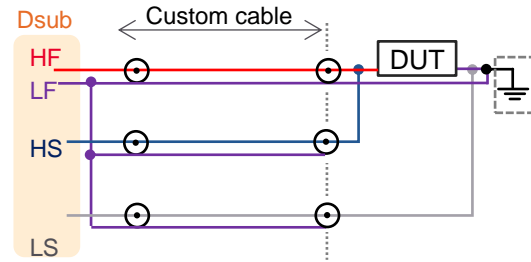

Two-wire, guarded connection

- The simpler two-wire configuration uses only the force terminals. Retain the sense terminals open.
- Shield HF by G to minimize the leakage current and stray capacitance from the cables.
- Shield G by LF, because G can be over 42 V when LF is floating.

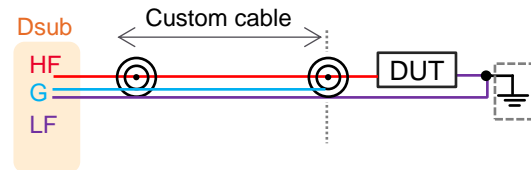

Keysight enables innovators to push the boundaries of engineering by quickly solving design, emulation, and test challenges to create the best product experiences. Start your innovation journey at www.keysight.com.