

A GREATER MEASURE OF CONFIDENCE

KEITHLEY
A Tektronix Company

Using Electrometers & Picoammeters for Low-Level Current Measurements

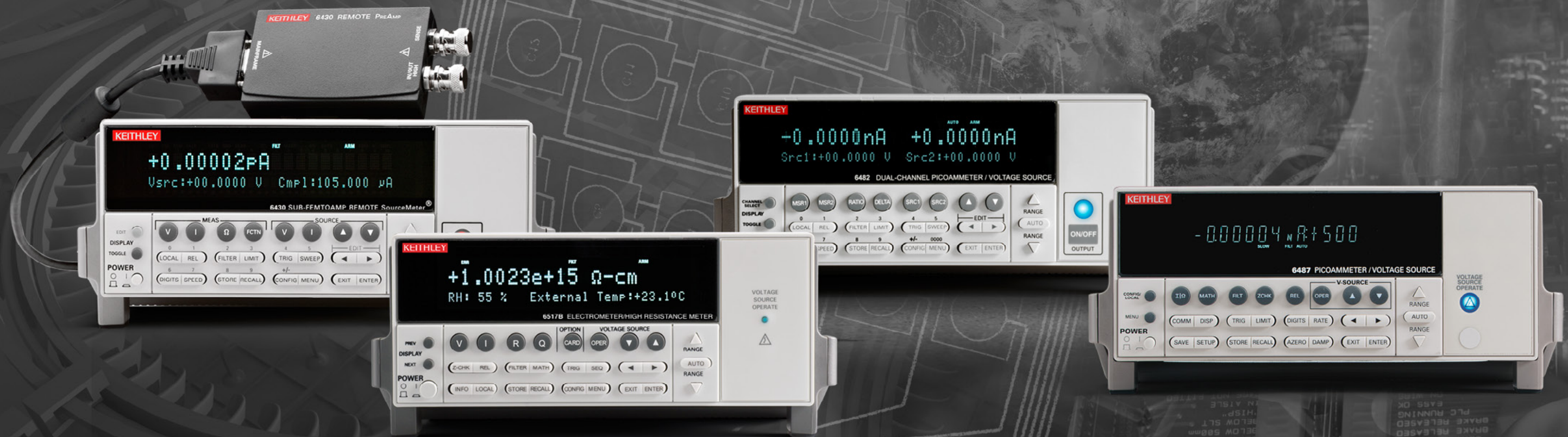

Measuring DC Amps Where the DMM Can't



Low-Level Current Measurement Applications

■ High-resistance Measurements of Materials

- Measuring high-resistance of materials by sourcing high voltage and measuring low current with a Model 6517B Electrometer and a Model 8009 Surface Resistivity Box

■ Leakage Measurement of Capacitors

- Measuring capacitor leakage by sourcing high voltage and measuring leakage current with a Model 6517B Electrometer

■ Simplified Insulation Resistance Measurements

- Measuring insulation resistance by sourcing high voltage and measuring low current with a Model 6517B Electrometer or a Model 6487 Picoammeter

■ Testing Breakdown Voltages and Resistances

- Powering devices and measuring breakdown voltages and resistances by sourcing voltage and measuring low currents with a Model 6487 Picoammeter

■ Simplified Two-Channel, Powered Measurements

- Aligning and monitoring ion beams and optics, testing multiple devices, and testing multi-pin devices with a Model 6482 Dual-channel Picoammeter

What is an Electrometer?

Like digital multimeters, (DMM,) Keithley electrometers are instruments that measure charge, currents, voltages, and resistances. However, electrometers measure beyond the capabilities of standard DMMs by measuring charges with 10fC resolution, currents with 100aA resolution, and resistances up to 200TΩ. Electrometers are used where there is a need for extreme sensitivity or where there is a need for multiple types of sensitive electronic measurements.

What is a Picoammeter?

Measuring low DC currents often demands a lot more than a DMM can deliver. Generally, DMMs lack the sensitivity required to measure currents less than 100nA. Even at higher currents, a DMM's input voltage drop (voltage burden) of hundreds of millivolts can make accurate current measurements impossible. The low voltage burden of a picoammeter makes it function much more like an ideal ammeter than a DMM, so it can make current measurements with high accuracy, even in circuits with very low source voltages. Keithley picoammeters combine the economy and ease of use of a DMM with low current sensitivity near that of an electrometer.



Want assistance, a quote, or to place an order?
[Contact us online.](#)

■ Join the discussion on our [application forum.](#)

Simplified High Resistance Measurements of Materials Using a Keithley Electrometer

High Resistance Measurements

Resistance is most often measured with a DMM, which can make measurements up to about 200MΩ. However, in some cases, resistances in the gigohm and higher ranges must be measured accurately. These cases include such applications as characterizing high megohm and gigohm resistors, determining the resistivity of insulators, and measuring the insulation resistance of printed circuit boards. These measurements are made by using an electrometer, which can measure both very low current and high impedance voltage.

Common High Resistance Measurements

- **Insulation Resistance** – Insulation resistance (IR) is the ratio of a DC applied voltage between two electrodes and the total current between them. Examples of insulation resistance measurements include measuring the leakage between traces on a printed circuit board or the resistance between conductors in a multi-conductor cable.
- **Volume Resistivity Measurements** – Volume resistivity is the electrical resistance through a one centimeter cube of insulating material and is expressed in ohm-centimeters.¹
- **Surface Resistivity Measurements** – Surface resistivity is the electrical resistance between two electrodes on the surface of an insulating material and is expressed in ohms (usually stated as ohms per square for clarity).¹

¹Both volume and surface resistivity measurements are obtained by taking wresistance measurements and then converting them to resistivity values by taking geometric considerations into account. Resistivity measurement setups are shown below in **Figure 1**. Both volume and surface resistivity measurements can be improved by using test fixtures like the Keithley Model 8009 (shown in **Figure 2**) and the Model 6517B Electrometer (shown in **Figure 3**).

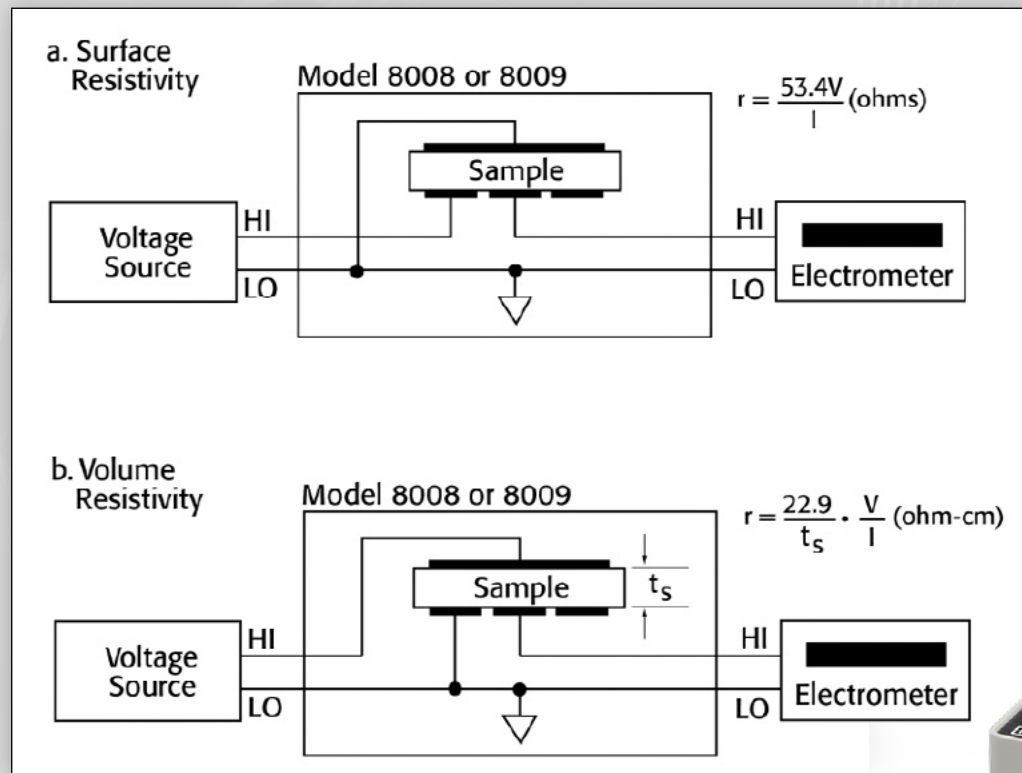

Figure 1. Resistivity measurements

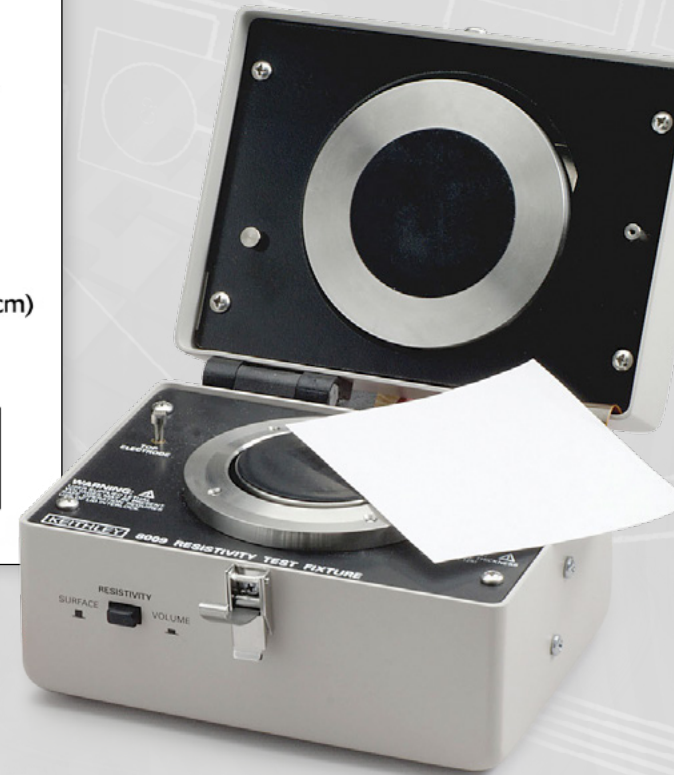

Figure 2. Model 8009 Resistivity Test Fixture

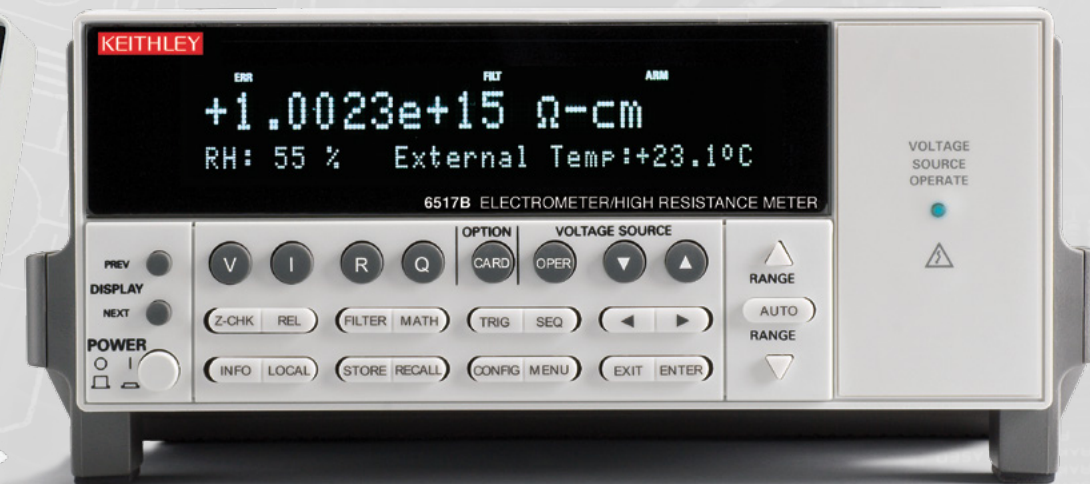

Figure 3. Model 6517B Electrometer/High Resistance Meter

Want assistance, a quote, or to place an order?
[Contact us online.](#)

■ Join the discussion on our [application forum](#).

Simplified Capacitor Leakage Measurements Using a Keithley Electrometer

Capacitor Leakage Measurements

Capacitors are very important in all areas of electronics. From timing circuits to sample and hold applications, we depend on capacitors to act in a nearly ideal fashion. In many cases, however, complex electrochemical interactions cause capacitors to fall short of perfect. One of the less ideal properties that a capacitor has is leakage, or insulation resistance (IR).

Capacitor leakage can either be expressed as insulation resistance, expressed in megohm-microfarads (computed by dividing the resistance value by the capacitance) or by leakage current at a specific voltage. The Model 6517B Electrometer is particularly useful for this application because it can display either resistance or leakage current and will source up to 1000V DC.

Capacitor leakage is measured by applying a fixed voltage to the capacitor under test and measuring the resulting current. The leakage current will decay exponentially with time, so it's usually necessary to apply the voltage for a known period (the "soak" time) before measuring the current. Improved performance will result if a forward-biased diode (D) is included in the circuit, as shown in **Figure 4**. The diode acts like a variable resistance, low when the charging current to the capacitor is high then increasing in value as the current decreases with time. The series resistor can be much smaller since it is only needed to prevent overload of the voltage source and damage to the diode if the capacitor becomes short-circuited.

For statistical purposes, a quantity of capacitors is often tested to produce useful data. Obviously, it is impractical to perform these tests manually, so some sort of automated test system is required. **Figure 5** illustrates such a system, which employs a Model 6517B Electrometer/High Resistance Meter and switching cards that are installed in a switching mainframe. The Model 6517B is particularly useful for this application because it can display either resistance or leakage current and will source up to 1000V DC.

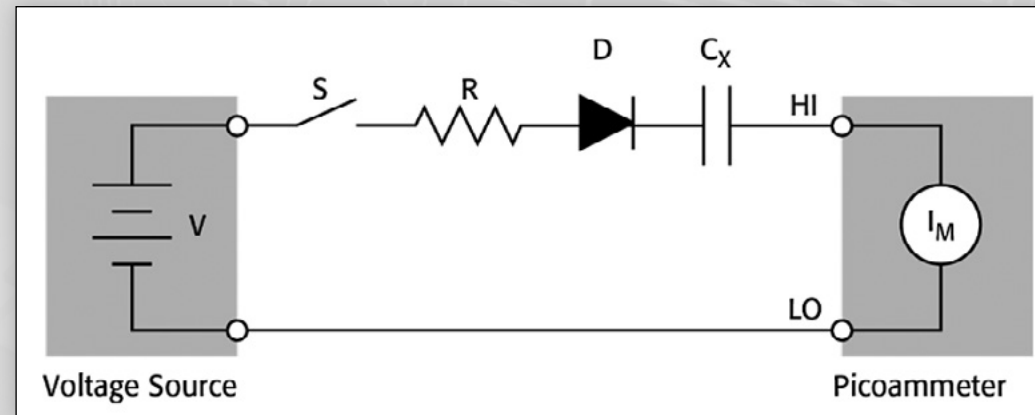

Figure 4. Capacitor leakage test circuit with diode

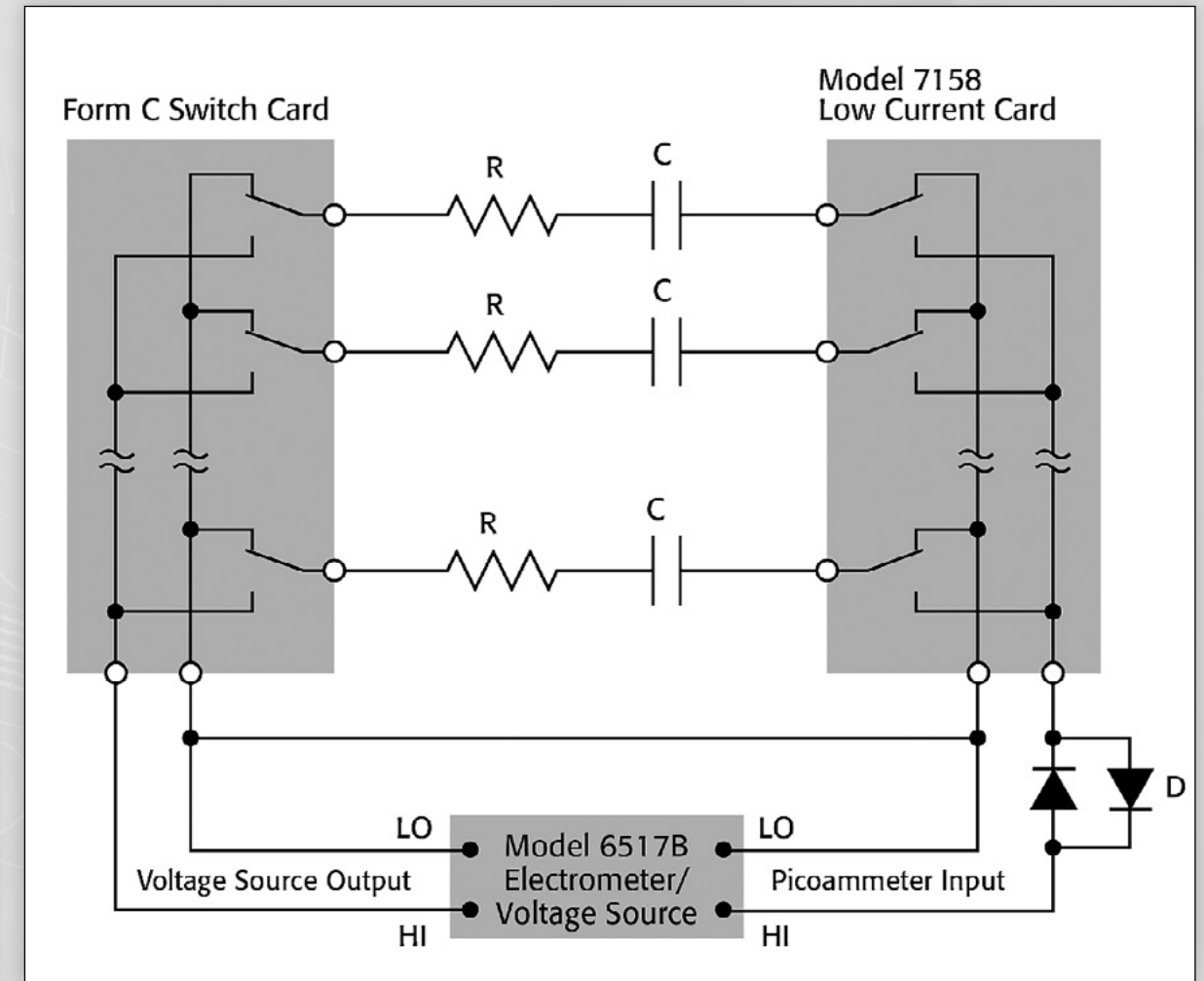

Figure 5. Capacitor leakage test system

Want assistance, a quote, or to place an order?
[Contact us online.](#)

■ Join the discussion on our [application forum](#).

Simplified Insulation Resistance Measurements Using a Keithley Electrometer

High Resistance Measurements

Resistance is most often measured with a DMM, which can make measurements up to about 200MΩ. However, in some cases, resistances in the gigohm and higher ranges must be measured accurately. These cases include applications such as characterizing high megohm resistors, determining the resistivity of insulators, and measuring the insulation resistance of printed circuit boards. These measurements are made by using an electrometer, which can measure both very low current and high impedance voltage.

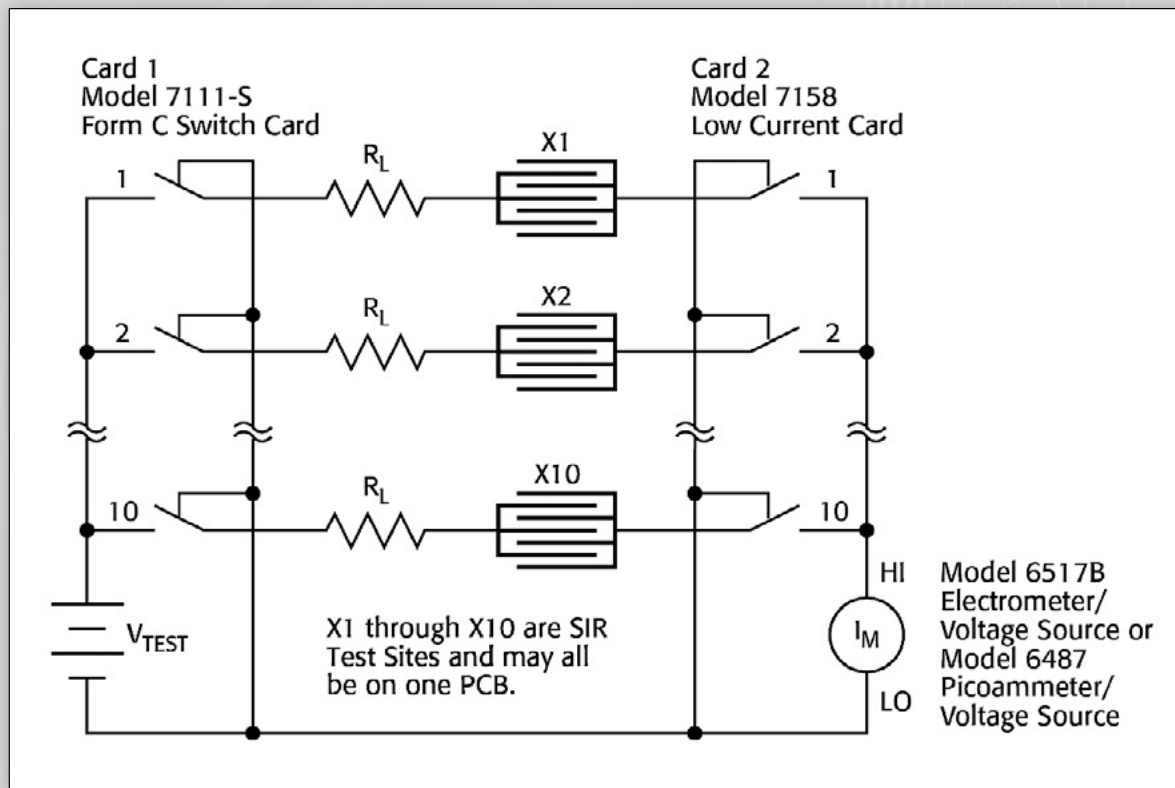

Figure 6. PCB insulation resistance measurement

Common Insulation Leakage Measurements

- Connector insulation resistance** – Given today’s ever-shrinking circuit geometry and the higher frequencies of electronic signals, isolation is an important consideration for reliability and crosstalk. Isolation is typically tested by applying a voltage across two pins in a connector and measuring the resulting current that flows between them. The corresponding resistance from the test is compared to a predetermined threshold value. If the resistance level is too low, the connector is rejected. **Figure 7** shows the electrical equivalent of a connector; the isolation resistance is identified as R_{iso} . When testing very high ohmic devices, the measured resistance may change significantly in response to a change in the applied voltage, an effect known as the voltage coefficient of resistance.
- PCB surface insulation resistance** – Low surface insulation resistance (SIR) of a printed circuit board (PCB) can degrade the performance of the circuits on the board considerably. Factors that affect a board’s surface insulation resistance include the board material used, the presence of coatings such as solder masking or conformal coatings, board cleanliness, and relative humidity. The measured insulation resistance typically ranges from $10^7\Omega$ to $10^{16}\Omega$. **Figure 6** shows a test setup for measuring PCB surface resistances.

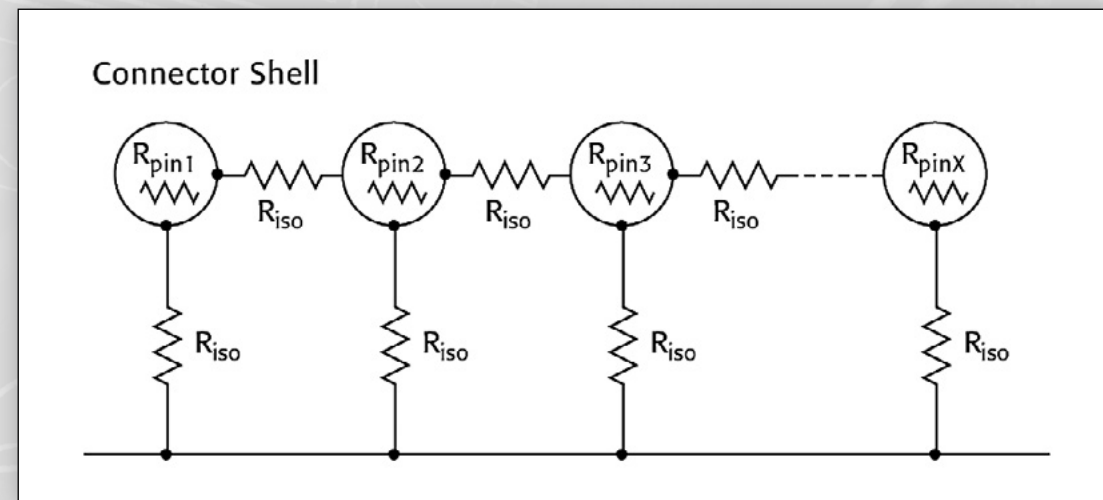

Figure 7. Electrical equivalent of a connector showing pin continuity and isolation resistance

Want assistance, a quote, or to place an order?
[Contact us online.](#)

Join the discussion on our [application forum](#).

What are the Keithley Model 6514 and 6517B Electrometers?

What is an Electrometer?

Like DMMs, Keithley electrometers are instruments that measure charge, currents, voltages, and resistances. However, they go beyond the capabilities of standard DMMs by measuring charges with 10fC resolution, currents with 100aA resolution, and resistances up to 200TΩ (using the 6517B's voltage source).

The Keithley Model 6514 and 6517B Programmable Electrometers are the industry's leading electrometers. Their superior sensitivity and performance increase utility and boost productivity in a variety of applications from high resistance measurements, to physics and chemistry research, to new product development. The Model 6517B's programmable voltage source adds to instrument density and ease of control by combining both measurement and sourcing capabilities.

Please visit the Keithley website at www.keithley.com for detailed specifications for the **Models 6514 and 6517B**

- **Application Note: [Low Current Measurements](#)**
- **White Paper: [Optimizing Low-Current Measurements and Instruments](#)**

For other information, please contact your local applications engineer.

Keithley Model 6514 and 6517B Electrometers Key Specifications



Features	6514 Electrometer	6517B Electrometer/High Resistance Meter
Resistance Measurement Max/Min	200 GΩ / 10 Ω	10 PΩ (1016 Ω) / 100Ω
Charge Measurement Max/Min	20μC / 10 fC	2μC / 10 fC
Current Measurement Max/Min	20mA / 100aA	
Voltage Measurement Max/Min	200V / 10μV	
Voltage Sourcing	N/A	1000V / 5mV resolution
Max readings / sec	1,200	450
Computer Interface	GPIB, RS-232	
Connectors/ Cabling	Triax	Triax (measurement), Banana (voltage source), Thermocouple Input
System-level automation	Digital I/O, TriggerLink, Analog out	

Keithley Electrometer Features

DMM-Like Operation

The Models 6514 and 6517B Electrometers feature easy, DMM-like operation via the front panel, with single-button control of important functions such as resistance measurement. They can also be controlled via a built-in IEEE-488 interface, which makes it possible to program all functions over the bus through a computer controller.

Unlike a DMM, however, electrometers have lower offset currents and input burdens. Typically, offset currents in DMMs are tens or hundreds of picoamps, which severely limit their low current measuring capabilities compared to the Model 6514 or 6517B, which each have $<3\text{fA}$ input bias currents.

The Model 6514's and 6517B's feedback ammeter designs minimize voltage offsets in the input circuitry, which can affect current measurement accuracy. The instruments also allow active cancellation of its input voltage and current offsets, either manually via the front panel controls or over the bus with IEEE-488 commands.

Scanner Cards (6517B)

Two scanner cards are available to simplify scanning multiple signals., such as in production testing of capacitors or other circuitry. Either card can be easily inserted in the option slot of the instrument's back panel. The Model 6521 Scanner Card offers ten channels of low-level current scanning. The Model 6522 Scanner Card provides ten channels of high impedance voltage switching or low current switching.

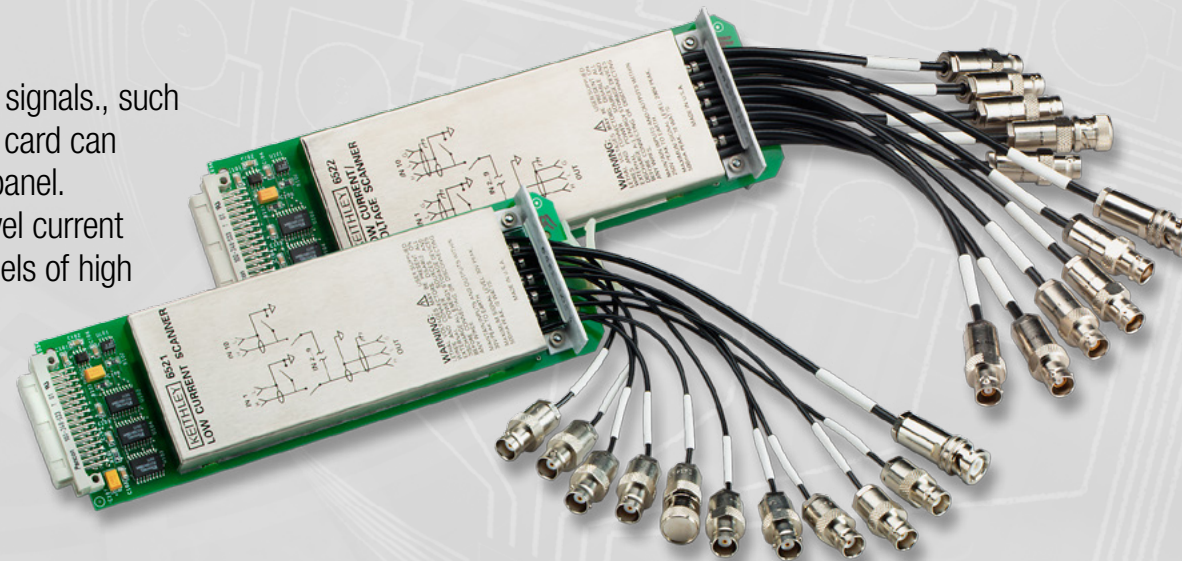

Alternating Polarity Resistance/Resistivity (6517B)

The Model 6517B uses the alternating polarity method for resistance/resistivity measurements, which virtually eliminates the effect of any background currents in the sample. First and second order drifts of the background currents are also canceled out. By alternating the polarity of an applied voltage, this method typically produces a highly repeatable, accurate measurement of resistance (or resistivity).

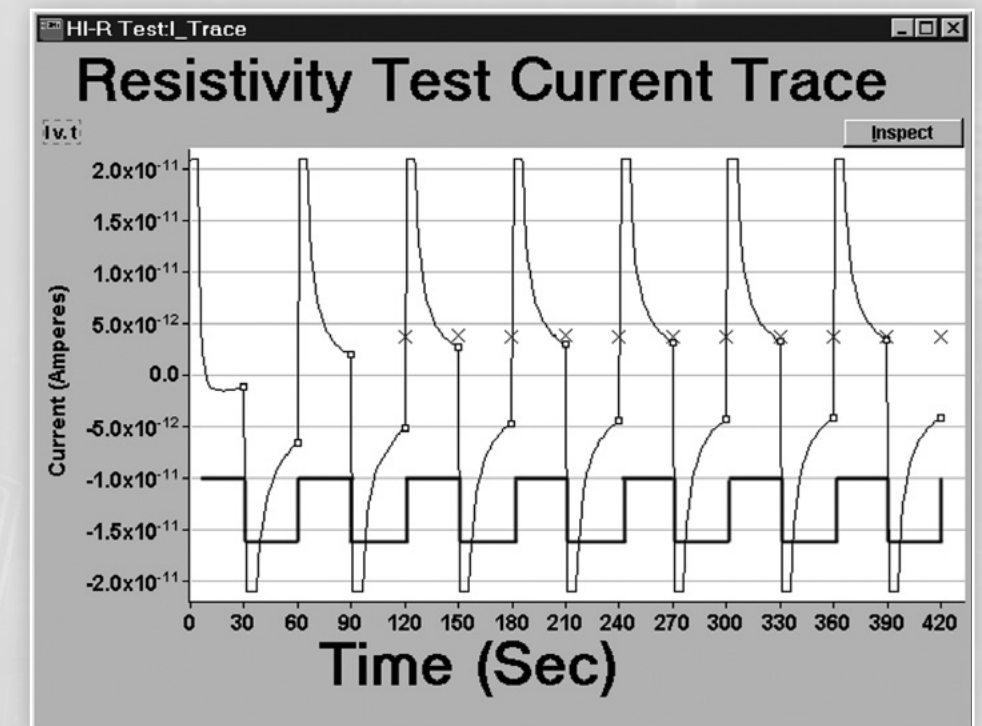

Want assistance, a quote, or to place an order?
[Contact us online.](#)

■ Join the discussion on our [application forum.](#)

Testing Breakdown Voltages and Resistances Using a Keithley Picoammeter

High Resistance Measurements

Resistance is most often measured with a DMM, which can make measurements up to about 200MΩ. However, in some cases, resistances in the gigohm and higher ranges must be measured accurately. These cases include such applications as characterizing high megohm resistors, determining the resistivity of insulators and measuring the insulation resistance of printed circuit boards. These measurements can be made with a picoammeter/voltage source, utilizing the precision high voltage source and picoamp measurement capabilities to make accurate resistance measurements.

High resistance measurements often use the constant voltage method. The basic configuration of the constant voltage method using a picoammeter is shown in **Figure 8**.

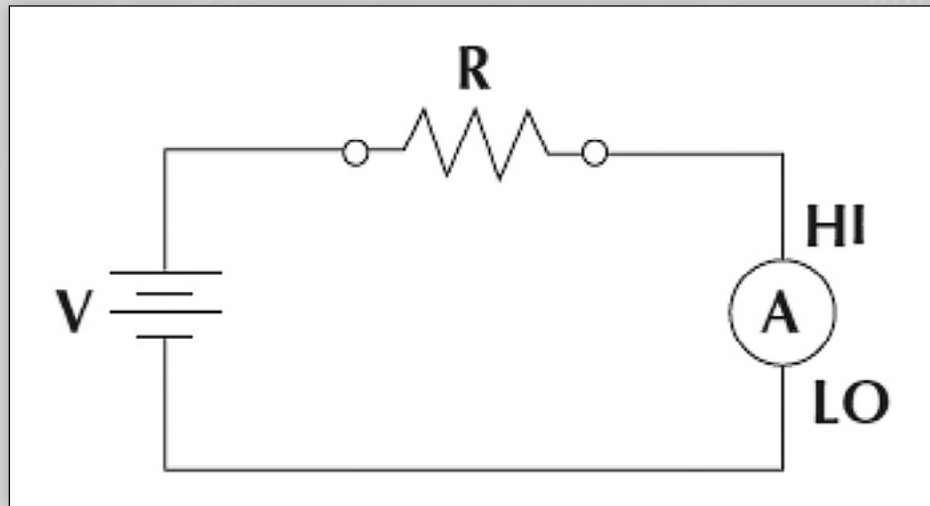

Figure 8. Constant voltage method for resistance measurements

In this method, a constant voltage source (V) is placed in series with the unknown resistor (R) and an ammeter (A). Since the voltage drop across the ammeter is negligible, essentially all the test voltage appears across R. The resulting current is measured by the ammeter, and the resistance is calculated using Ohm's Law ($R = V/I$). High resistance is often a function of the applied voltage, which makes the constant voltage method preferable to the constant current method used on DMMs.

Why would I need voltage source with my picoammeter?

- **To power devices** – Built-in voltage sources allow devices under test to be powered without the use of additional external equipment, saving money, time, and frustration.
- **To test breakdown voltages** – Devices and insulation can be biased to a high voltage to test at what point the insulator or device becomes electrically conductive (important in manufacturing quality testing and in device and materials research).
- **To test high resistances** – Higher voltages allow greater resistances to be measured.

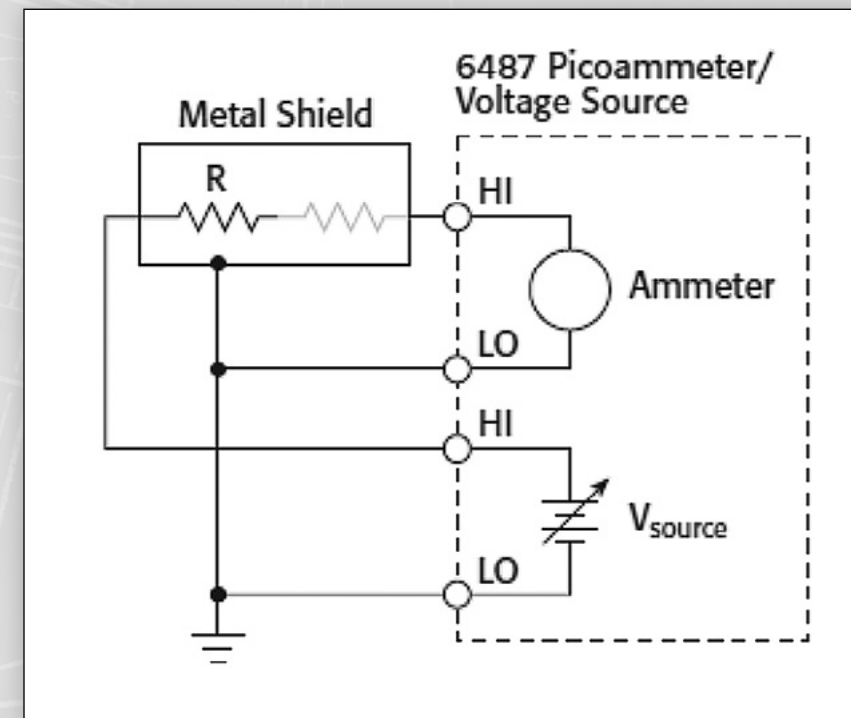

Figure 9. Model 6487 used to make high resistance measurements

Want assistance, a quote, or to place an order?
[Contact us online.](#)

- Join the discussion on our [application forum](#).

Simplified Two-Channel, Powered Measurements Using a Keithley Picoammeter

Ratio and Delta Modes for Beam Alignment Applications

Ratio and delta measurements, which show the ratio and difference, respectively, between two channels, can significantly improve efficiency in beam alignment applications by performing these calculations on-instrument. Important in many different fields from high energy particle beam monitoring to ion beam monitoring and fiber optics, the beam alignment procedure involves measuring a signal from a detector and adjusting the position of the source to align it to the sensor such that it matches a calibrated source/detector pair. Ratio and delta measurements can help to provide immediate feedback about how far out of alignment these beams are, which helps the operator more quickly adjust the source. The Model 6482 Dual Channel Picoammeter, as shown in **Figure 10**, not only has these measurement capabilities, but also has dual voltage biases, which allow these sensors to be powered without the need for additional equipment.

Common Powered Two-Channel Measurements

Ion Beam Monitoring – Focused ion beam systems are often used for nanometer-scale imaging, micromachining, and mapping. Careful monitoring of the magnitude of the beam current with an ion detector is critical. These sensors accept and put out a small current. Oftentimes, multiple ion beams and sensors are operated concurrently and require powered sensors. The Keithley Model 6482 can power these sensors while taking picoamp measurements, saving space, reducing the number of instruments needed, and simplifying control.

Beam alignment – Laser diodes, fiber optics, high-energy particle beams, and ion beams all need to be aligned in many applications. The ratio and delta modes in the Keithley Model 6482 simplify these alignment procedures by doing these measurements in real time and reporting these values to the operator, who can then adjust the beams quickly and easily.

Multiple Device Testing – Multi-channel devices increase throughput and reduce maintenance burden by increasing the number of channels in the same form factor. The Keithley Model 6482 can power and measure two devices concurrently, reducing the number of instruments needed.

Multi-pin Device Testing – Multi-pin devices, such as dual diodes, ICs, and other components often need multi-channel, simultaneous current testing. Multiple channels allow one instrument to take measurements on multiple pins, opening up new possibilities for tests and increasing throughput.

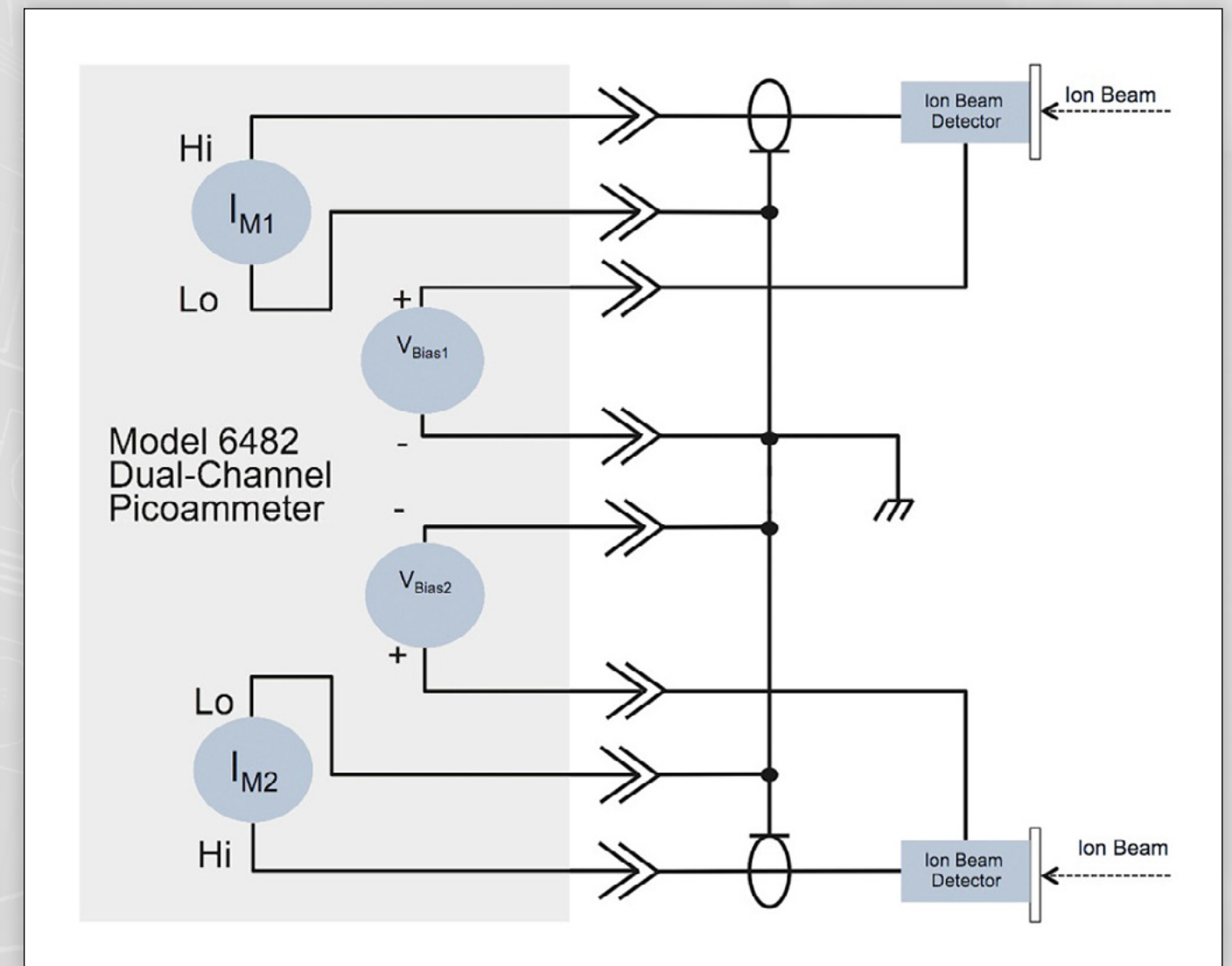

Figure 10. Two-channel ion beam comparison

Want assistance, a quote, or to place an order?
[Contact us online.](#)

■ Join the discussion on our [application forum.](#)

What are Keithley's Model 6482, 6485, and 6487 Picoammeters?

What is a Picoammeter?

Measuring low DC currents often demands a lot more than a DMM can deliver. Generally, DMMs lack the sensitivity required to measure currents less than 100nA. Even at higher currents, a DMM's input voltage drop (voltage burden) of hundreds of millivolts can make accurate current measurements impossible. The low voltage burden of a picoammeter makes it function much more like an ideal ammeter than a DMM, so it can make current measurements with high accuracy, even in circuits with very low source voltages. Keithley picoammeters combine the economy and ease of use of a DMM with low current sensitivity near that of an electrometer. Keithley offers three picoammeters, the Model 6485 Picoammeter, the Model 6487 Picoammeter/ Voltage source, and the Model 6482 Dual Picoammeter/Voltage Source.

What are Keithley Model 6482, 6485, and 6487 Picoammeters?

The Keithley Model 6482, 6485, and 6487 picoammeters are the industry's leading picoammeters. Superior sensitivity and performance increase utility and boost productivity in a variety of applications from sensor monitoring, to leakage currents, to physics and chemistry research, to new product development. The Model 6487's programmable 500V precision voltage source adds high-resistance and breakdown voltage testing capabilities. The Model 6482 boasts two measurement channels and the ability to power devices under test with its dual 30V bias sources.



Figure 11. Front and rear panels of the Keithley Model 6482 Dual-Channel Picoammeter

Keithley Model 6482, 6485, and 6487 Picoammeters Key Specifications

Features	6485 Picoammeter	6487 Picoammeter/ Voltage Source	6482 Dual Picoammeter/ Voltage Source
Current Measurement Max / Min	20 mA / 20 fA	200 GΩ / 10 Ω	20 mA / 1 fA
Resistance Measurement Max/Min	N/A	10 PΩ (10 ¹⁶ Ω)	N/A
Channel Count	1	1	1
Voltage Sourcing	N/A	500 V / 200 μV resolution	30 V / 400 μV resolution
Max readings / sec (via GPIB)	900	900	900
Buffer size	2500	3000	3000 (per channel)
Computer Interface	GPIB, RS-232		
Connectors/ Cabling	BNC	Triax	Triax (and BNC via included adapters)
System-level automation	TriggerLink, Analog out		

Please visit the Keithley website at www.keithley.com for detailed specifications for the **Models 6482, 6485, and 6487**

- Application Note: [Low Current Measurements](#)
- White Paper: [Optimizing Low-Current Measurements and Instruments](#)

For other information, please contact your local applications engineer.

Keithley Model 6482, 6485, and 6487 Picoammeters Features



Common Picoammeter Measurements Requiring a Voltage Source

High resistance components – The high voltage source present in the Keithley **Model 6487 Picoammeter** allows high voltages to be measured quickly and accurately by sourcing a voltage and measuring the resulting current.

High resistance materials – Paired with the Keithley **Model 8009 Resistivity Test Fixture**, the Keithley Model 6487 can measure surface and volume resistivities.

Breakdown voltage identification – The voltage source can sweep voltage to determine when electrical breakdown occurs in resistors or devices in component testing and materials research.

Resistor voltage coefficient – Very high ohmic value resistors may exhibit a significant non-linear change in resistance with a change in applied voltage. This effect is known as the voltage coefficient. The voltage coefficient is the percent change in resistance per unit change in applied voltage.

DMM-Like Operation

The Models 6482, 6485, and 6487 are designed for easy, DMM-like operation via the front panel, with single-button control of important functions such as math functions and zeroing measurement functions. They can also be controlled via built-in IEEE-488 and RS-232 interfaces, which make it possible to program all functions over the bus through a computer controller.

Advantages of two picoamp measurement channels

Increase channel density – In research and manufacturing applications where bench and rack space is at a premium, higher channel density becomes very valuable. The Keithley **Model 6482 Dual-Channel Picoammeter** offers twice the channel density of earlier Keithley picoammeters.

Increase instrument control and improve setup – Fewer instruments to control and setup decreases setup and programming time.

Quickly compare two signals – On-instrument delta and ratio calculations in the Model 6482 help to quickly compare the signals coming from multiple sensors or multiple-pin ICs, components, and devices.

Want assistance, a quote, or to place an order?
[Contact us online.](#)

■ Join the discussion on our [application forum](#).

Measuring DC Amps Where The DMM Can't

Electrometers

- Model 6430**
Measure 10 aA to 100 mA
Source 50 aA to 100 mA
- Model 6517B**
Measure 1 fA to 20 mA
Source 5mV to 1000V
- Model 6514**
Measure 100 aA to 20 mA

Picoammeters

- Model 6487**
Measure 10 fA to 20 mA
Source 200µV to 500V
- Model 6482**
Measure 1 fA to 20mA (x2)
Bias 30V on each channel
- Model 6485**
Measure 10 fA to 20mA

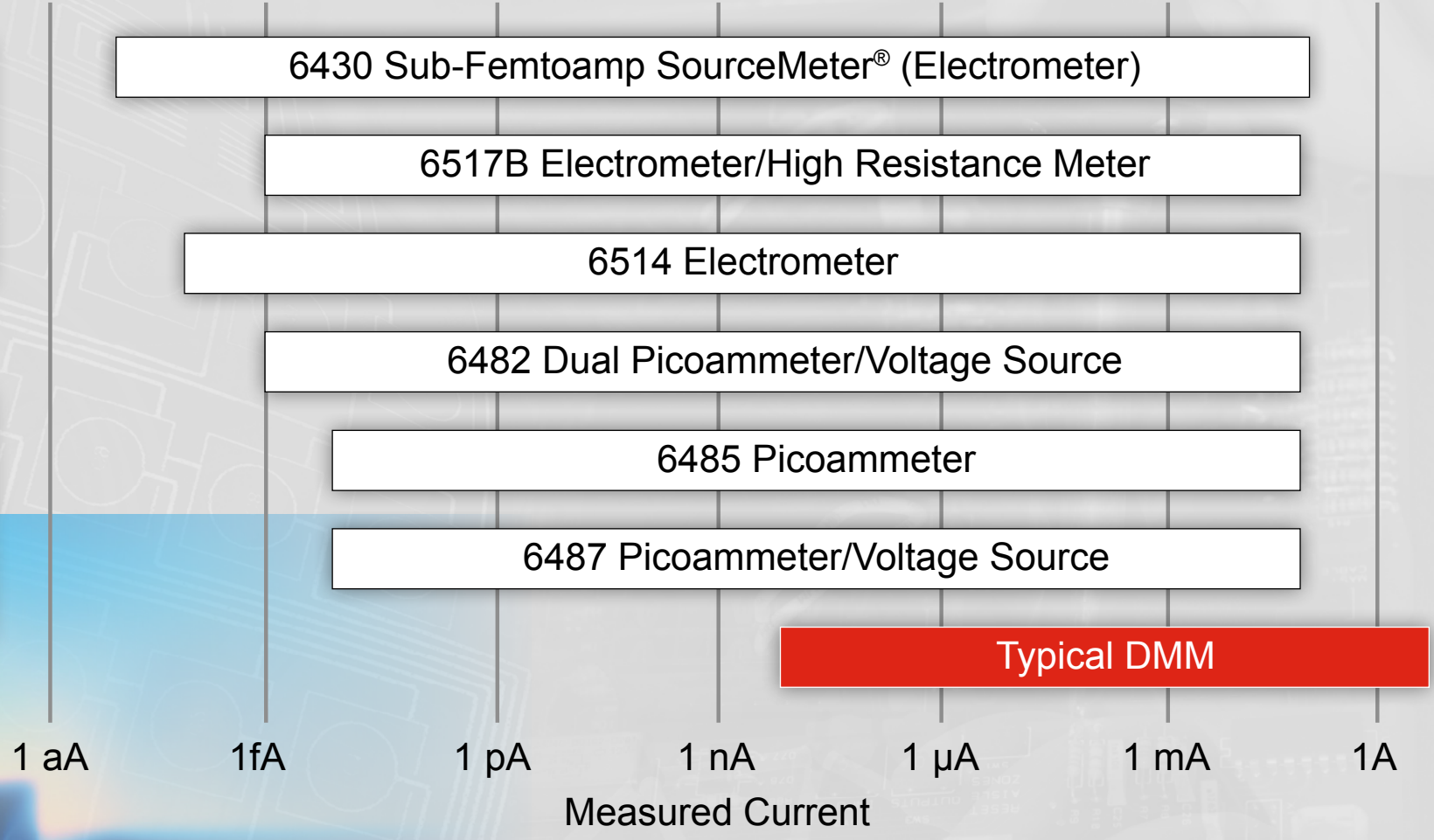

Want to learn more about applications for Keithley's electrometers & picoammeters for low-level current measurements?



Keithley Instruments hosts an online applications forum to encourage idea exchange, discussions among users. [Join the discussion today.](#)

To learn more about how Keithley's Electrometers & Picoammeters for Low-Level Current Measurements contact your local Keithley representative or [ask us a question online.](#)

Contact us by phone, fax, mail, or email:

KEITHLEY CORPORATE HEADQUARTERS

Keithley Instruments, Inc.
28775 Aurora Road
Cleveland, Ohio 44139
Phone: 440-248-0400
Toll-free: 800-552-1115
Fax: 440-248-6168
info@keithley.com

Consult with a Keithley applications engineer and learn how to get the most from your Keithley products

WORLDWIDE HEADQUARTERS

Within the USA: 1-888-534-8453
Outside the USA: + 1-440-248-0400
Email: applications@keithley.com
Additional contact information at www.keithley.com

EUROPE

Germany: (+49) 89 849 307 40

ASIA

China: (+86) 10 8447 5556
Japan: (+81) 3 6714 30 70
Korea: (+82) 2 574 7778
Taiwan: (+886) 3 572 9077



Specifications are subject to change without notice. All Keithley trademarks and trade names are the property of Keithley Instruments, Inc. All other trademarks and trade names are the property of their respective companies.



A Greater Measure of Confidence

KEITHLEY INSTRUMENTS, INC. ■ 28775 AURORA RD. ■ CLEVELAND, OH 44139-1891 ■ 440-248-0400 ■ Fax: 440-248-6168 ■ 1-888-KEITHLEY ■ www.keithley.com

BRAZIL

55-11-4058-0229
www.keithley.com

GERMANY

49-89-84930740
www.keithley.de

JAPAN

Tokyo: 81-3-6714-3070
Osaka: 81-06-6396-1630
www.keithley.jp

MALAYSIA

60-4-643-9679
www.keithley.com

TAIWAN

886-3-572-9077
www.keithley.com.tw

CHINA

86-10-8447-5556
www.keithley.com.cn

INDIA

080-30792600
www.keithley.in

KOREA

82-2-6917-5000
www.keithley.co.kr

MEXICO

52-55-5424-7907
www.keithley.com

UNITED KINGDOM

044-1344-392450
www.keithley.co.ukw

FRANCE

01-69868360
www.keithley.fr

ITALY

02-5538421
www.keithley.it

SINGAPORE

01-800-8255-2835
www.keithley.com.sg