

Ensuring that Power Supply Performance Meets Your Requirements

Details beyond the specifications that can impact how well the power supply meets your requirements

Most engineers feel that they understand power supplies very well. Power supplies are considered one of the simplest instruments since they tend to be a one-function, DC device which outputs a controlled voltage. But of course there is much more to power supplies. While a power supply's specifications adequately describe performance for most applications, cost, time, and human resource limitations prevent the specification of all aspects of a power supply's (or any instrument's) performance. You will want to understand the power envelope of the power supply so that it will be able to deliver the power at the voltage and current parameters that you need for your work. For development, characterization, and testing of circuits that generate or measure low level signals, then the selection of the design topology of the power supply and investigation into its common mode current can be a necessity so that the power supply does not interfere with circuit performance. Similarly, if you are developing a device with multiple isolated circuits, then you will want your power supply not to degrade the isolation of your device. When you use your power supply as an accurate voltage source for testing your circuit over its operating voltage range or as a calibrating source, you will want to ensure that you can obtain the specified accuracy of the supply at the input to the circuit-under-test. Applications such as these will require a more detailed investigation into a power supply's characteristics.

Understand the Power Envelope of the Power Supply

The most significant decision is ensuring that sufficient power is available to energize the device-under-test (DUT). While this is obvious, it is important to be aware that different types of power supplies and sources have different power envelopes. One type of power supply has a rectangular power envelope in which any current can be supplied to the load at any voltage level. See *Figure 1a*. This is certainly the most versatile power envelope. A second type of supply can have multiple-rectangular envelopes for multiple ranges (such as the two-rectangular envelope shown in *Figure 1b*). The value of this type of power envelope is that it permits higher values of one parameter at the expense of the other parameter. For example a supply with this type of envelope can output a higher level of current, but at a lower maximum voltage. Some supplies output a hyperbolic envelope, a more continuous transition than a multiple range power supply. With this power envelope, one parameter is inversely proportional to the other (*Figure 1c*). High power output supplies tend to have the multi-range or hyperbolic envelope. Be cognizant of what

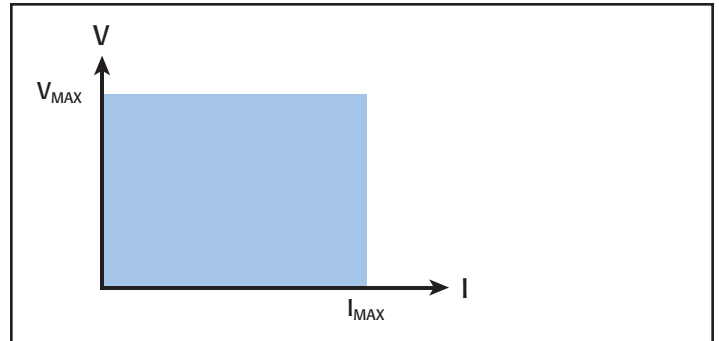

Figure 1a. Rectangular power supply envelope. Any current level can be delivered at any voltage.

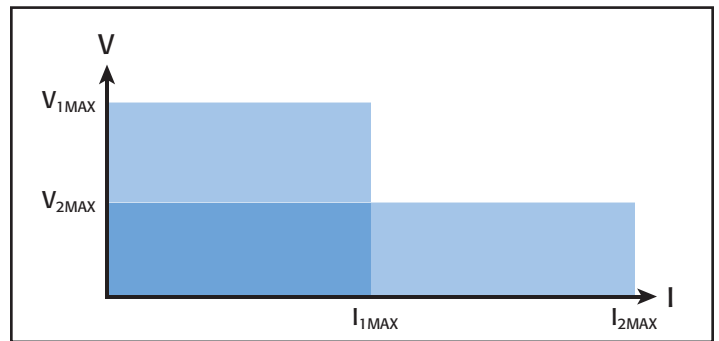

Figure 1b. Multi-range output. This characteristic allows higher voltages at lower currents and higher currents at lower voltages.

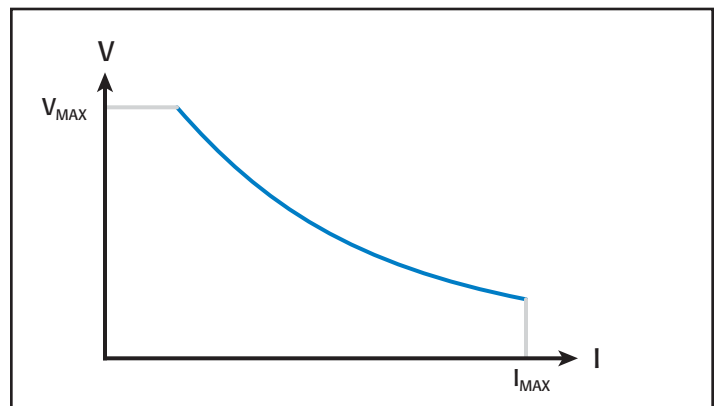

Figure 1c. Hyperbolic output characteristic. Maximum voltage and current follow a curve.

your application requires, so that the supply you select delivers the required power at the levels of voltage and current at which you will need to test.

The Type of Design Determines Noise Performance

If you are powering a circuit that operates at a very low voltage or a circuit that uses or measures very low currents such as a transducer detector that must pick-up millivolts or microamp current signals, then noise from external sources may cause problems. The power supply, itself, is one noise source, and this noise can be broken into two components: normal mode noise, and common mode noise. Normal mode noise is noise generated across the power supply's output terminals due to the power supply's internal circuitry. Common mode noise is earth-referenced noise originating from the power line and stray capacitance across the main transformer. For sensitive circuits, linear power supplies provide much lower normal mode output noise than supplies designed using switching technology. The trade-off is that linear power supplies have a low power, conversion efficiency and can be heavy and large. Switching supplies are endowed with improved power-conversion efficiency, and can house more output power in a smaller enclosure. For noise-sensitive circuits, a linear supply can have five-to-10 times lower noise (5mVpp vs. greater than 50mVpp) than a switching supply. Any time that noise is an important concern, use a linear supply, such as the Keithley Series 2200 single and multiple channel power supplies, if possible.

The Effects of and a Measurement Technique for Assessing Common Mode Noise Current

Linear power supplies also, generally, have lower common mode noise than switching supplies. Common mode noise is generated whenever changing voltages, such as AC voltages and transients (dv/dt) on either the primary or the secondary windings of an isolation transformer couple current across the barrier. Any noise current generated on the primary (secondary) must return

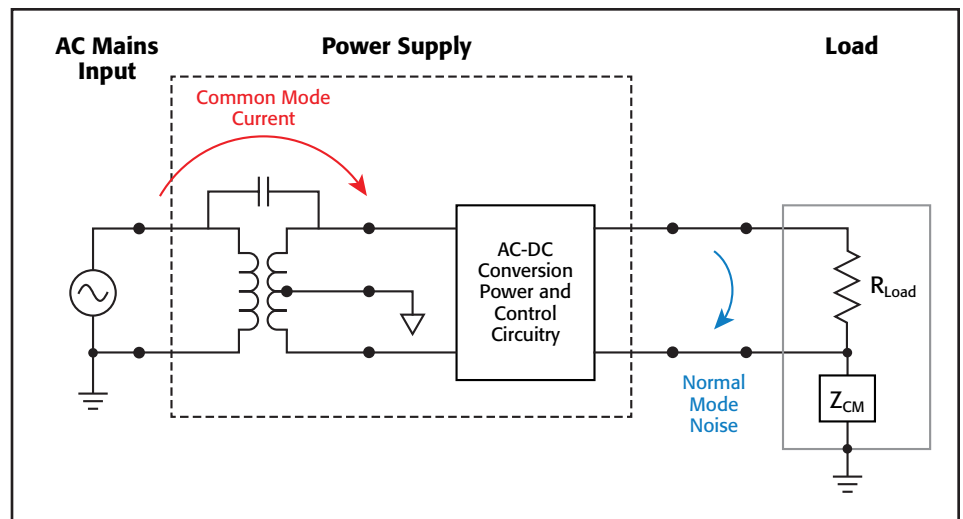

Figure 2. Normal mode and common mode noise currents.

to the primary (secondary) in order to complete the circuit. Whenever this current flows through an impedance, a noise voltage is generated, which under some circumstances, can degrade load (or device-under-test, DUT) performance or cause load-monitoring, measurement inaccuracies. The magnitude of the noise term is directly related to the voltage rise time and the unshielded or stray capacitance of the power supply isolation transformer. Voltage transients from rectifier diodes (on the secondary) turning on and off and either the 60Hz line movement or the abrupt voltage transient common with a switching power supply's primary circuit are all sources of common mode noise. **Figure 2** shows a simple block diagram of a power supply. The quality of transformer construction with sufficient shielding between primary and secondary can minimize the stray capacitance between primary and secondary. With minimal coupling capacitance, the noise current flowing through the load will generally not affect the load's operation or impact measurements on the load. If the transformer primary and secondary are not shielded sufficiently from each other, then the coupling capacitance can be large and milliamps of current can flow into the load creating performance problems and load current measurement errors. For low power and sensitive components, modules, or end products, evaluate

your power supply for low common mode performance. See the sidebar on measuring a power supply's common mode current. Keithley Series 2200 power supplies have common mode currents under $10\mu A$.

The Importance of Good Isolation from Earth Ground

A further indication of the quality of a power supply is how isolated the output is from the power line. A power supply with high isolation further minimizes noise on the supply's output. A good level of isolation impedance includes parameters greater than $1G\Omega$ in parallel with less than $1nf$ and shielded well enough to support less than $5\mu A$ of common mode current. The trouble is, not many instruments exceed or even meet these figures. Low frequency 60Hz designs may meet the common mode current specification, but fall short of the DC resistance and capacitance figures while switching designs may have low capacitance and higher DC isolation but excessive common mode current. In some applications, the DC isolation resistance and capacitance are more important than common mode current. One example where the high impedance is important is when a supply must power a circuit driven by a linear amplifier. In this situation, the power supply is part of the load on the linear amplifier and a large power supply capacitance can create stability problems

Characterizing a power supply's isolation to chassis

The three main power supply isolation parameters are insulation resistance between the primary and the secondary windings of the power supply transformer, stray capacitance between the windings and common-mode current.

DC Characteristic: Insulation resistance

The insulation resistance measurement is a DC characterization of the isolation between the low terminal of the power supply and the chassis. A well designed power supply can output voltage between the high and low terminals at a substantial voltage above its chassis ground. The low output terminal of the Keithley Series 2200 multi channel power supplies can float up to 240V above chassis ground. The insulation resistance between the line input on the primary winding and the low terminal on the secondary winding is an important DC characteristic. While keeping the power supply unplugged or floating, 200V is sourced into its low terminal. The resulting current is measured on a sensitive current measurement instrument.

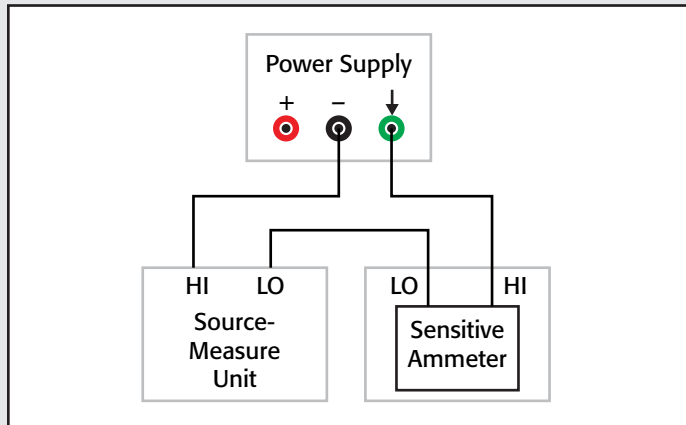

Figure 3a. Test setup for measuring a power supply's DC isolation resistance.

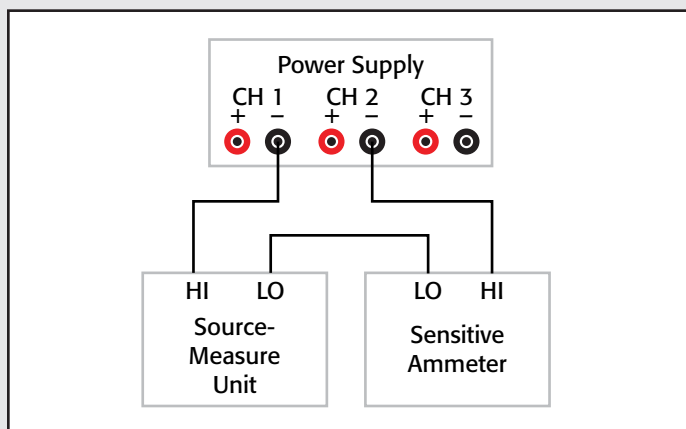

Figure 3b. Channel-to-channel DC isolation test setup.

A DC isolation measurement was made on a Keithley series power supply with the LO-ground terminals driven to 200V. The current drawn was 130nA, resulting in excellent insulation resistance of 1.5GΩ.

AC Characteristics: Stray Capacitance and Common Mode Current

The stray capacitance is an AC characteristic of the power supply isolation. Depending on the area and distance between the primary and secondary coils as well as the insulating material constant, AC coupling will result between the windings. If not properly designed, the operation on the primary side of the transformer will disrupt the operation of the secondary side. This capacitance can be measured using an LCR meter connected between the low and the chassis ground with the power supply floating.

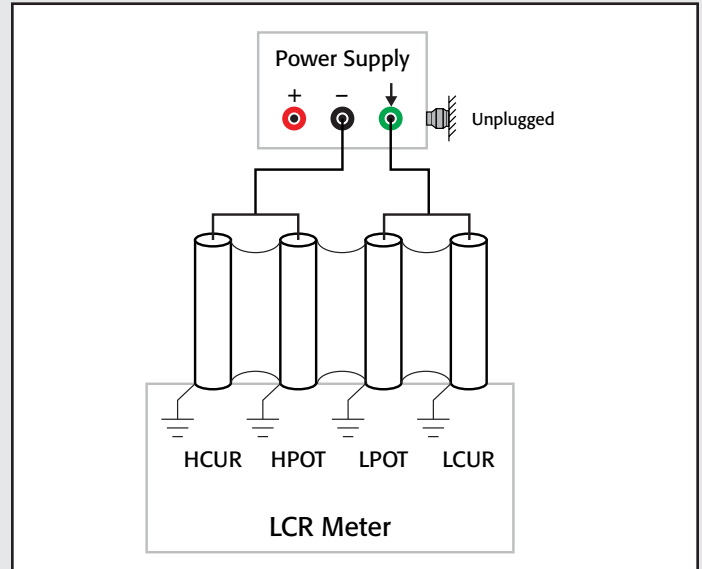

Figure 4. Test setup for measuring a power supply's Stray capacitance.

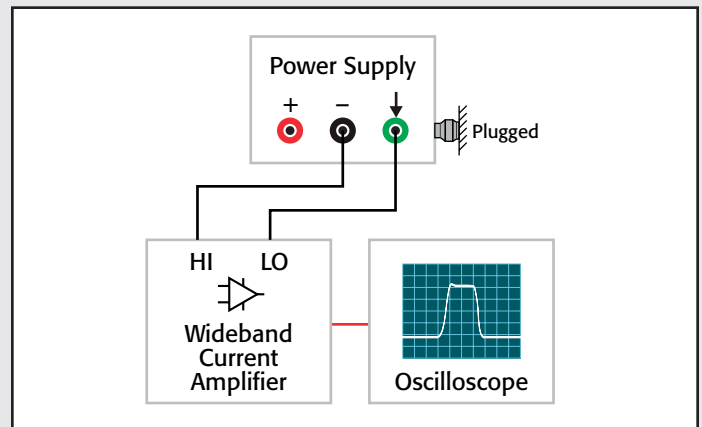
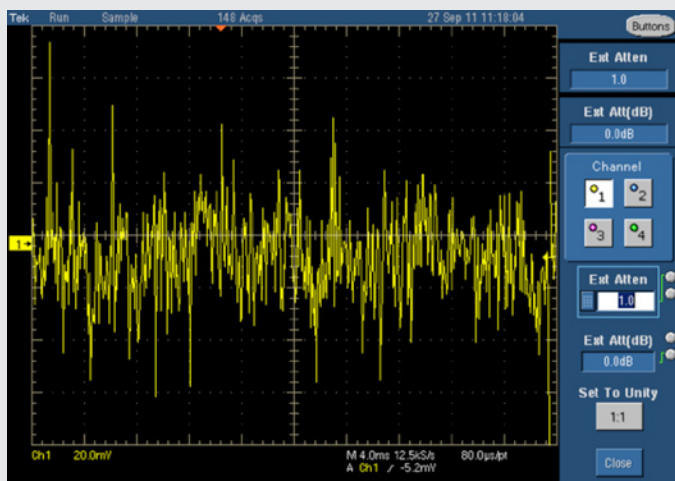

Figure 5. Test setup for measuring a power supply's common mode current.

At 1kHz, the stray capacitance is about 18nF on a Keithley Series 2200 power supply. At 100Hz, the capacitance is measured to be 20nF on a Keithley Series 2200 power supply.

The common-mode current characterizes the noise path between the low terminal and the chassis plane of the power supply while the power supply is in operation. A well designed power supply will exhibit very small common-mode current, often in the micro-amps region. The design must involve proper shielding on both the primary and the seconding windings of the power supply transformer to reduce common-mode current leakage. This low current can be captured on a high sensitivity oscilloscope with a wideband current amplifier used to amplify the current.

As shown in *Scope Plot 1*, a Keithley Series 2200 power supply has an amplified common-mode voltage of 40mV through the current amplifier. This corresponds to about a 4 μ A common mode current. A similar power supply from another major manufacturer has a 20–30 μ A common mode current, five to seven times greater than the Keithley power supplies.



Scope Plot 1. Keithley Series 2200 common mode current

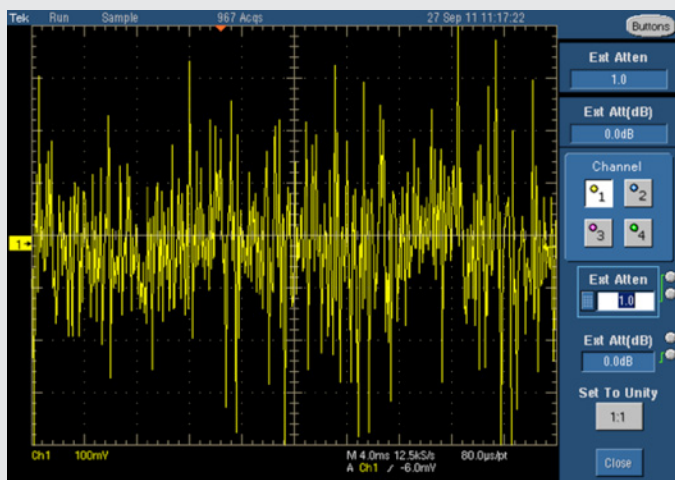

Scope Plot 2: A comparable power supply common mode current.

for the amplifier. Alternatively, a supply that is used to power a low voltage resistive divider, or a very low current measurement circuit may need low common mode current regardless of the isolation impedance. See the Sidebar on Characterizing a Power Supply's Isolation to Chassis. Refer to *Figures 3A, 4, and 5*, which show measurement techniques for assessing the quality of a power supply's isolation from AC ground.

Generally, the higher the isolation, the lower the noise coupled through the supply from the AC power line. The problem becomes more confusing when other instruments are also required in the application. In this case, insufficient DC isolation in the power supply can provide a conduction path for a high common mode current from one of the other instruments. The bottom line is that for any particular power supply application, one must understand the effect of the power supply isolation resistance and capacitance on the DUT, and the path or loop where the primary and secondary common mode currents flow in order to consider if a noise voltage (common mode current \times impedance) will be developed and whether or not the noise will be excessive.

Ensuring Sufficient Isolation Between Channels of a Multiple Channel Power Supply

If your DUT requires individual isolated power supply sections, then you will need either a number of individual isolated supplies or a single multi-channel output power supply. If you choose to use a multi-channel power supply, you will want to ensure that the isolation between the power supply channels is greater than the isolation required between the DUT circuits. That is not something you can easily determine from a multi-channel power supply's data sheet (or from the application circuit for that matter). When the isolation between circuits in a DUT is critical, you should consider actually measuring the power supply's isolation between its channels. Refer to *Figure 3b* for the test circuit to test-channel-channel isolation. Some power supplies do not provide isolation between channels so care must be taken when selecting a power supply for use in these applications. The Keithley 2220-30-1 Dual Channel Programmable DC Power Supply and the 2230-30-1 Triple Channel Programmable DC Power Supply have two and three fully isolated channels respectively.

Maximizing Output Accuracy

If tight control of voltage at the load is essential for research experimentation, device characterization or production testing, then a careful review of the power supply's output accuracy and read-back specifications are important. However, that accuracy can be compromised if the supply is controlling the voltage at its output terminals. What you need is feedback control right at the DUT. That means your supply should include sense connections (remote sensing) that can be connected to the DUT where the power leads are connected. The sensing circuits measure the

voltage at the DUT so that the supply can compensate for any voltage drop in the test leads (see *Figure 6*).

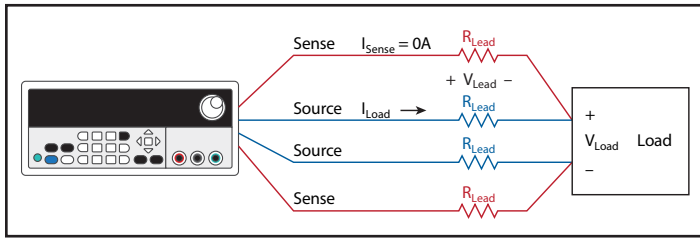

Figure 6. Remote sensing ensures that the programmed voltage is delivered to the load.

No matter how accurate your power supply output is, you cannot guarantee that the programmed output voltage is the same as the voltage at the DUT's load. This is because a power supply with two source terminals regulates its voltage only at its output terminals. However, the voltage you want regulated is at the DUT load, not at the power supply's output terminals. The power supply and the load are separated by lead wires that have a resistance, R_{Lead} , determined by the length of the lead, the conductivity of the conductor material, and the geometry of the conductor. The voltage at the load is:

$$V_{Load} = V_{Programmed} - 2 * V_{Lead} = V_{Programmed} - 2 * I_{Load} * R_{Lead}$$

If the load requires high current, then I_{Load} is high and V_{Lead} can easily be a few tenths of a volt, especially if the power supply leads are long, as can be the case in an automated test rack. A voltage at the load could easily be 80mV to 160mV lower than the desired voltage (with 2A to 4A flowing through a five foot length of 0.004 Ω /foot, 16-gauge wire).

The remote sensing technique solves the problem of voltage drop in the leads by extending the power supply feedback loop to the input of the load. Two sense lines from the power supply are connected to the DUT power inputs. These sense leads are voltage measuring lines that connect to a high impedance voltage measuring circuit in the power supply. Since the voltage measuring circuit is a high input impedance circuit, the voltage drop in the sense leads is negligible. The sense lead voltage measurement circuit becomes the feedback control loop for the power supply. The voltage at the load is fed back to the power supply by the sense leads. The power supply raises its output to overcome the voltage drop in the source leads and $V_{Load} = V_{Programmed}$. Thus, only with remote sensing can the accuracy of the power supply be applied to the load.

Conclusion

While simple from the standpoint that power supplies are single-function instruments, their power output envelope, their design topology (linear vs. switching), their isolation performance, and their ability to perform remote sensing are all considerations that are important for sophisticated and sensitive design and test applications. Since some of these parameters are not specified, the power supply may have to be evaluated. As discussed in this application note, some simple measurements can ensure that a power supply meets the intended need.

You can be assured that Keithley power supplies strive to maximize insulation and isolation to enable use of their supplies with the most sensitive circuitry. Finally, use remote sensing to overcome voltage drops in the leads and ensure that the programmed voltage is accurately applied to the load.

Specifications are subject to change without notice. All Keithley trademarks and trade names are the property of Keithley Instruments, Inc.
All other trademarks and trade names are the property of their respective companies.

KEITHLEY

A Tektronix Company

A Greater Measure of Confidence

KEITHLEY INSTRUMENTS, INC. ■ 28775 AURORA RD. ■ CLEVELAND, OH 44139-1891 ■ 440-248-0400 ■ Fax: 440-248-6168 ■ 1-888-KEITHLEY ■ www.keithley.com

BELGIUM

Sint-Pieters-Leeuw
Ph: 02-3630040
Fax: 02-3630064
info@keithley.nl
www.keithley.nl

CHINA

Beijing
Ph: 86-10-8447-5556
Fax: 86-10-8225-5018
china@keithley.com
www.keithley.com.cn

FRANCE

Les Ulis
Ph: 01-69868360
Fax: 01-69868361
info@keithley.fr
www.keithley.fr

GERMANY

Germering
Ph: 089-84930740
Fax: 089-84930734
info@keithley.de
www.keithley.de

INDIA

Bangalore
Ph: 080-30792600
Fax: 080-30792688
support_india@keithley.com
www.keithley.in

ITALY

Peschiera Borromeo (Mi)
Ph: 02-5538421
Fax: 02-55384228
info@keithley.it
www.keithley.it

JAPAN

Tokyo
Ph: 81-3-6714-3070
Fax: 81-3-6714-3080
info.jp@keithley.com
www.keithley.jp

KOREA

Seoul
Ph: 82-2-6917-5000
Fax: 82-2-6917-5005
keithley@keithley.co.kr
www.keithley.co.kr

MALAYSIA

Penang
Ph: 60-4-643-9679
Fax: 60-4-643-3794
sea@keithley.com
www.keithley.com

NETHERLANDS

Son
Ph: 040-2675502
Fax: 040-2675509
info@keithley.nl
www.keithley.nl

SINGAPORE

Singapore
Ph: 01-800-8255-2835
Fax: 65-6356-4483
sea@keithley.com
www.keithley.com.sg

TAIWAN

Hsinchu
Ph: 886-3-572-9077
Fax: 886-3-572-9031
info_tw@keithley.com
www.keithley.com.tw

UNITED KINGDOM

Bracknell
Ph: 044-1344-392450
Fax: 044-1344-392457
info@keithley.co.uk
www.keithley.co.uk