

# JBC

[www.jbctools.com](http://www.jbctools.com)

## INSTRUCTION MANUAL

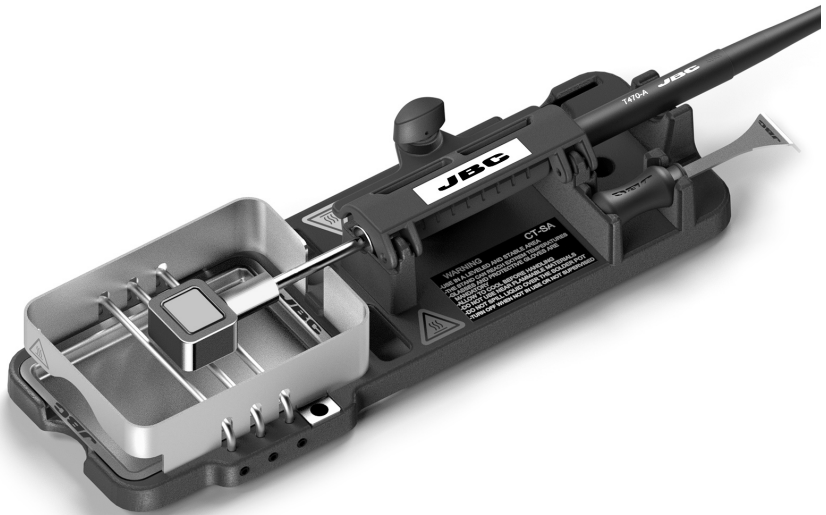

### CTS

Solder Pot Stand

This manual corresponds to the following reference:

CT-SA

## Packing List

The following items are included:

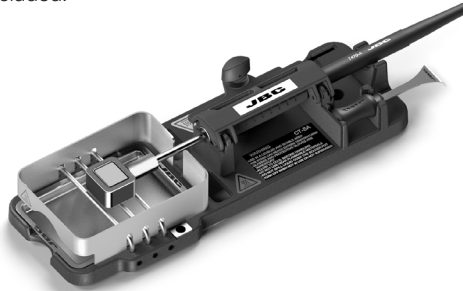

**Solder Pot Stand** .....1 unit

*Handle and Cartridge are not included*



**Spatula 17mm / 0.67in** ..... 1 unit  
Ref. 0018606



**Spatula 39mm / 1.54in** ..... 1 unit  
Ref. 0018607



**Spacers** ..... 2 units



**Allen Key Ø 2mm / 0.08in** ..... 1 unit



**Tray** ..... 1 unit



**Manual** ..... 1 unit  
Ref. 0029403

## Features

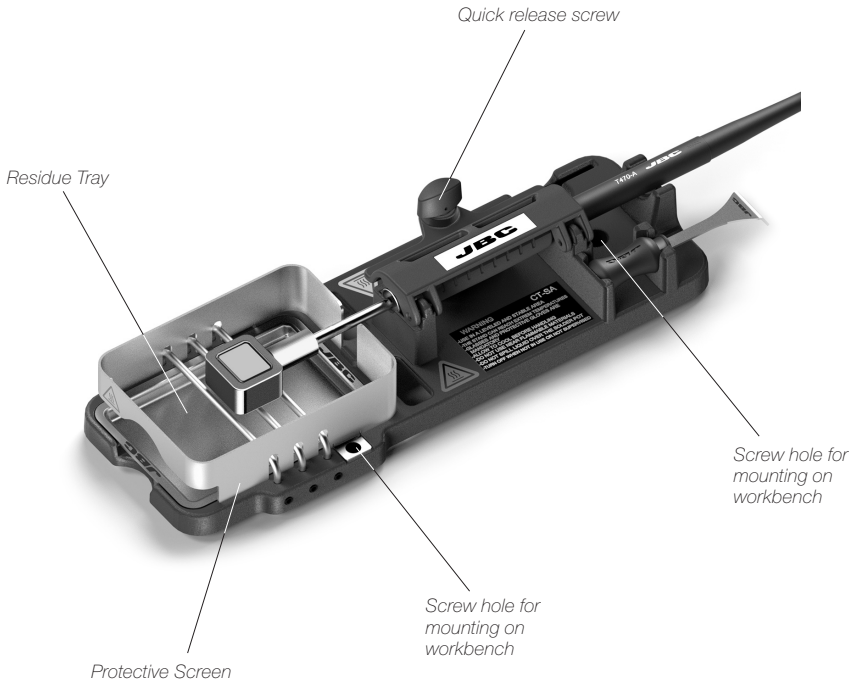

# Operation

CTS Solder Pot Cartridge Stand holds the handle **T245** or **T470** with its **Solder Pot Cartridge** to avoid it tipping over accidentally. Find the cartridges available in [www.jbctools.com](http://www.jbctools.com)  
As a safety precaution, before placing the handle, make sure the station is off and the tin is cold.

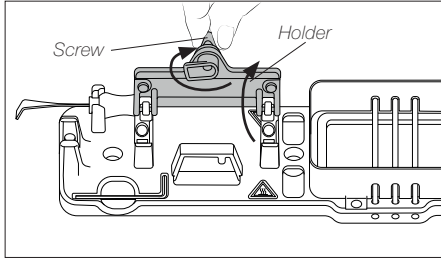

1. Unlock the screw and open the holder.

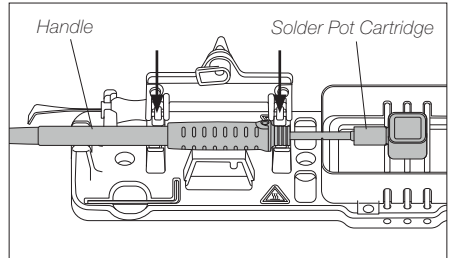

2. Place the handle with its solder pot cartridge previously inserted. Be careful to position it correctly.

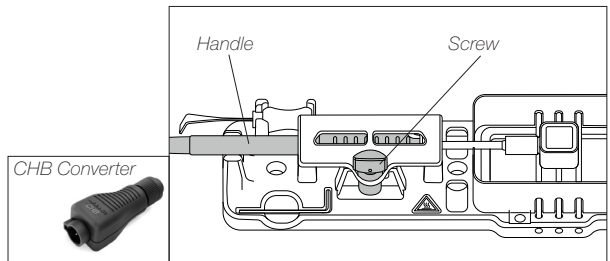

3. Once in place, lock the screw and connect the handle to the stand or directly to JBC stations or control units using CHB Converter.



- Do not melt "flux core solder".

- Recommended temperatures for fine wires (up to AWG 24 approx) and lead free solder is 300°C. For thicker wires, increase the temperature as necessary, but always the minimum possible.

## Fixing CTS to Workbench

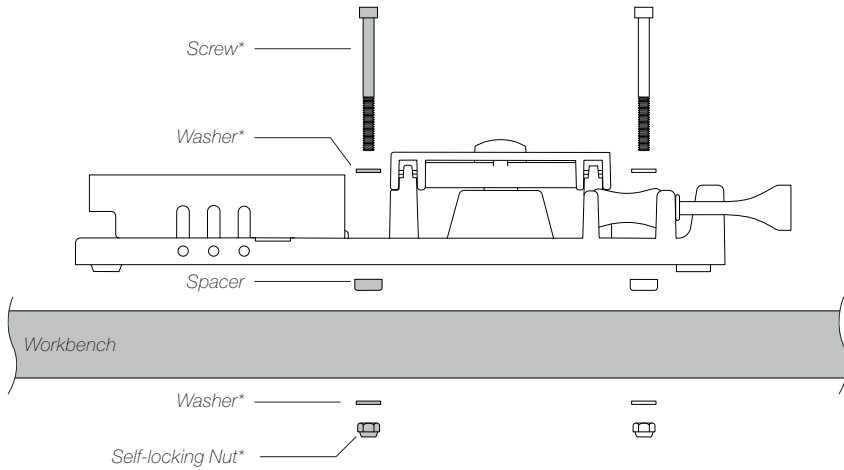

*\*Screws, washers and the self-locking nuts are not included.*

To protect the stand's rubber feet from wear and tear when fixing CTS in place put the spacers (Ref. 0014899) between the stand and the workbench.

Use screws (we recommend M4) and assemble them with washers and self-locking nuts to fix the CTS in place. Check that the stand is stable and leveled.

## Spatulas

Use the spatula to eliminate the dross (Oxide and other contaminants that form on the surface of molten solder)

Spatula 17mm / 0.67in



Spatula 39mm / 1.54in

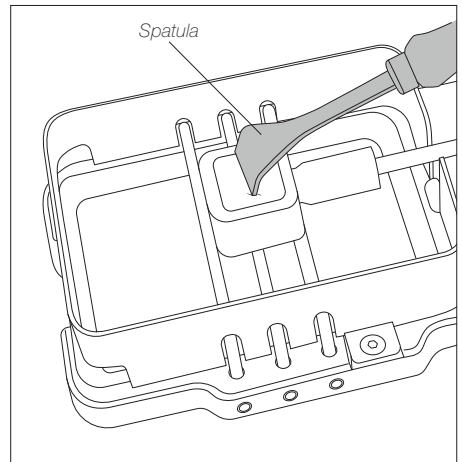

# Maintenance

- Allow to cool the device down before carrying out maintenance or storage.
- Always unplug the handle from the station and remove it from the stand.

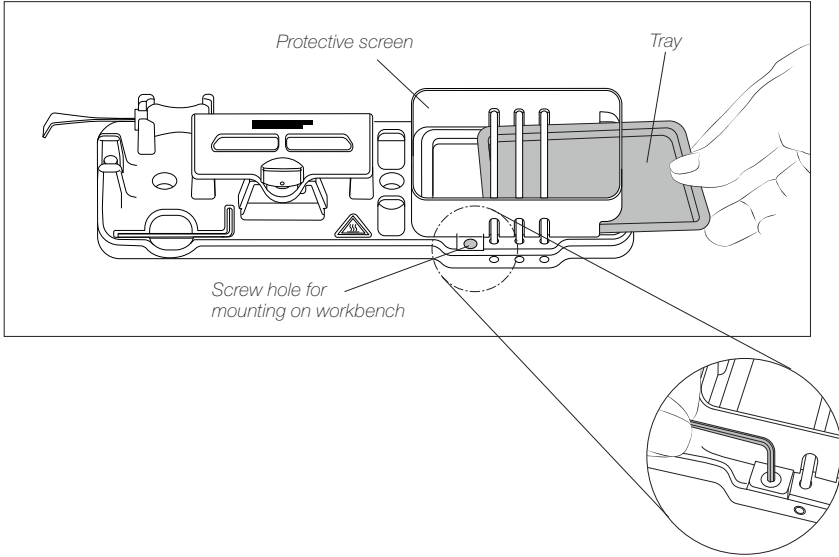

- Use a damp cloth to clean the tray and the protective screen. Alcohol can only be used for cleaning the metal parts.
- Replace any defective or damaged parts. Use original JBC spare parts only.
- Repairs should only be performed by a JBC authorized technical service.

## Safety



**It is imperative to follow safety guidelines to prevent electric shock, injury, fire or explosion.**

- Do not use the appliance for any other purpose than to hold the solder pot. It is not a tool stand.
- Do not use the equipment in environments with risk of fire or explosion.
- Allow to cool down before handling.
- Before inserting the cartridge, turn off the station. If T470 is used, insert the cartridge and tighten the screw to fix the cartridge inside the handle.
- Use on a level and stable surface.
- The stand can reach extreme hot temperatures. Protective glasses and gloves are recommended.
- Do not melt "flux core solder".
- Do not leave the appliance unattended when it is on. Turn off when not in use or not supervised.
- Do not use next to flammable materials. Do not spill liquid into the solder pot.
- Utmost care must be taken with liquid tin waste which can cause severe burns.
- Keep your workplace clean and tidy.
- Be careful with the fumes produced when soldering. The use of fume extractors is recommended.
- This appliance can be used by children aged from 8 years and above and persons with reduced physical, sensory or mental capabilities or lack of experience and knowledge if they have been given supervision or instruction concerning use of the appliance in a safe way and understand the hazards involved. Children must not play with the appliance. Cleaning and user maintenance must not be carried out by children without supervision.
- Maintenance must not be carried out by children unless supervised.

# Specifications

## CTS

### Solder Pot Stand

Ref. **CT-SA**

- Product Dimensions (aprox.): 92 x 48 mm  
(L x W) 3.62 x 1.89 in
- Net Weight: 999 g / 2.20 lb
- Package Dimensions and Weight: 342 x 155 x 120 mm / 1313 g  
(L x H x W) 13.46 x 6.10 x 4.72 mm / 2.89 lb

Complies with CE standards.  
ESD safe.

# JBC

## Warranty

JBC's 2 year warranty covers this equipment against all manufacturing defects, including the replacement of defective parts and labour.

Warranty does not cover product wear or misuse.

In order for the warranty to be valid, equipment must be returned, postage paid, to the dealer where it was purchased.



This product should not be thrown in the garbage.

In accordance with the European directive 2012/19/EU, electronic equipment at the end of its life must be collected and returned to an authorized recycling facility.

