

Revision level		Revision Record	Changed	Date	Approved	Date
part	drawing					
-	03					
-		See ECN 011820	A.A.C.	04/22/11	K.A.C.	04/22/11

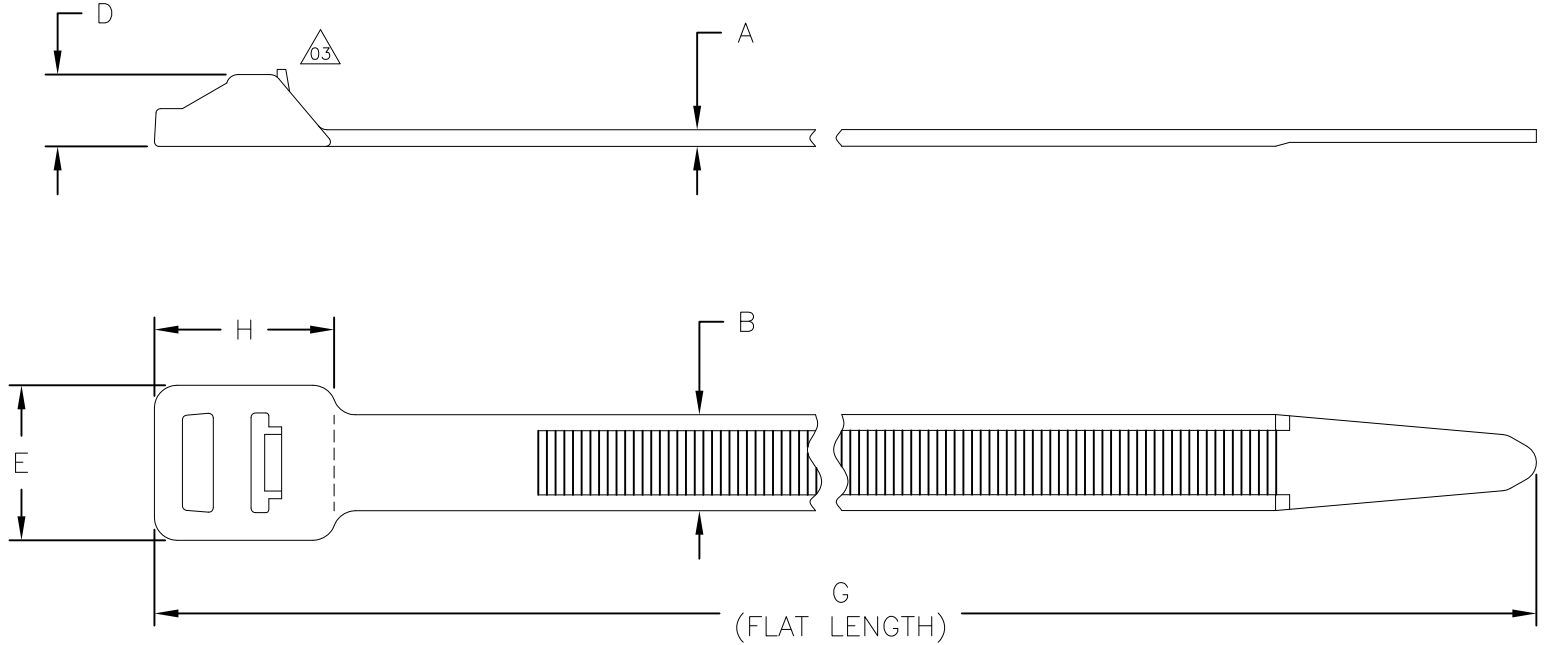

PRODUCT CODE DESCRIPTION

RT250S_UV

COLOR

(CONSULT FACTORY FOR AVAILABLE COLORS)

Aerospace Spec Tie SAE AS33671	Product Code	Cable Range (mm)	Material	A	B	D	E	G	H	Min Loop Tensile Strength (newtons)
no	RT250S_	12 to 50	PA66	1.9 ±0.2	12.5±0.2	9.5 ±0.5	20.0 ±0.5	230.0 ±5.0	22.4 ±1.0	1115
no	RT250S_UV		PA66UV							

SEE CHART

Material

Dimension tolerances unless otherwise specified
 .XXXX = ± .0130
 .XXX = ± .130
 .XX = ± .30
 .X = ± .8
 ∠ = ± 0.5 °

Dimension Units mm

PERFORMANCE SPECIFICATION

ACAD MECH
2010

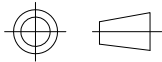

Drawn	A.A.M.	12/01/00
Approved	K.A.C.	04/22/11

Scale 1:1
 Computer File Number CT\CST\2250002_03
 Phase: Production

ALL PROPRIETARY RIGHTS IN THE SUBJECT MATTER SHOWN ON THIS DRAWING ARE EXCLUSIVE PROPERTY OF HELLERMANNNTYTON

HellermannTyton

7930 N. Faulkner Rd.
 Milwaukee, WI 53224
 Ph: (414) 355-1130
 Fx: (414) 362-8338

RT250S
RELEASABLE HEAVY DUTY
LASHING CABLE TIE

Drawing-No

CT2250002CST

Format

AH

Sheet 1 of 1