

Revision level		Revision Record	Changed	Date	Approved	Date
part	drawing					
—	03	See ECN 012244	A.A.C.	12/13/12	K.A.C.	12/13/12

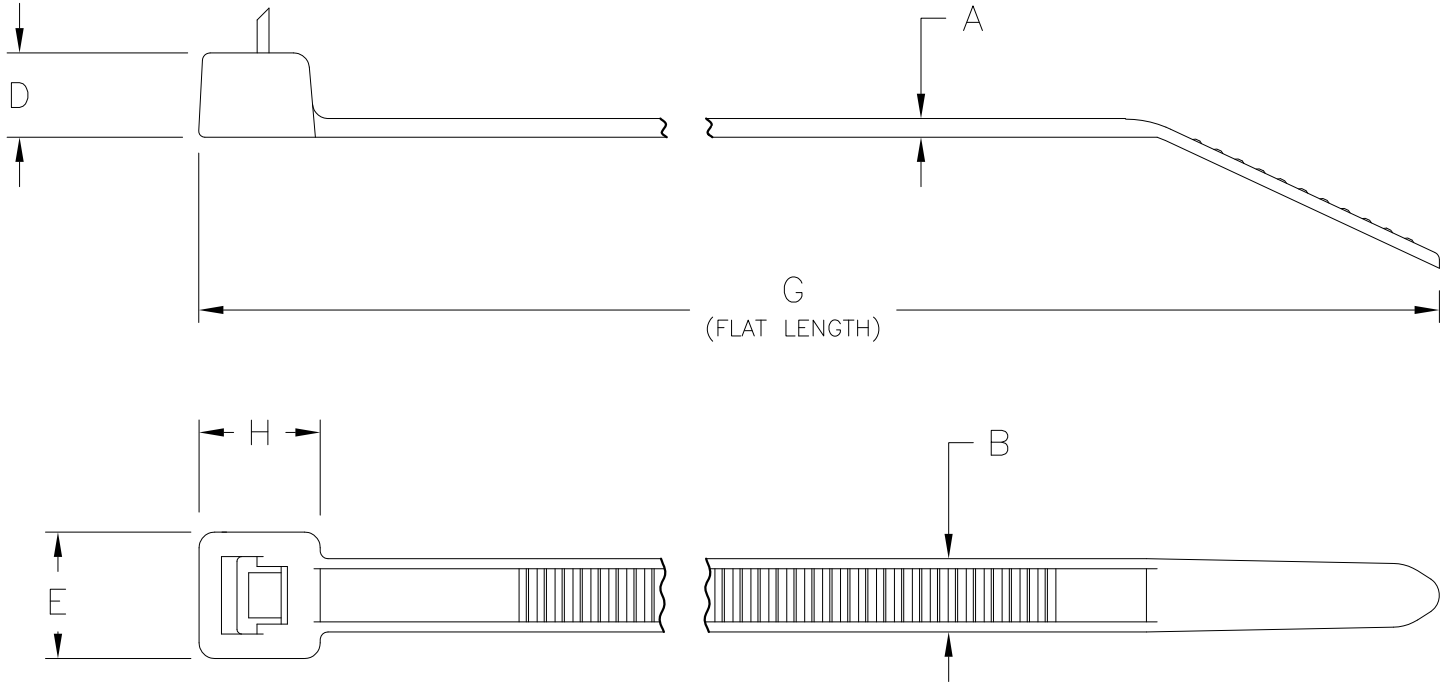

PRODUCT CODE DESCRIPTION

RT50S  
 COLOR  
 (CONSULT FACTORY FOR AVAILABLE COLORS)



Type	Cable Range (mm)	Material	A	B	D	E	G	H	Min Loop Tensile Strength (newtons)
RT50S_	1.5 to 35	PA66	1.2 ±0.2	4.6±0.2	5.7 ±0.5	8.0 ±0.5	160.0 ±12.0	7.0 ±0.5	225

SEE CHART

Material

Dimension tolerances unless otherwise specified  
 .XXXX =  
 .XXX =  
 .XX =  
 .X = NOTED  
 < =

Dimension Units mm

PERFORMANCE SPECIFICATION

ACAD MECH  
2013

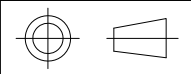

Drawn G.G.G. 10/8/91  
 Approved K.A.C. 10/01/10

Scale 2:1  
 Title  
 Computer File Number CT\CST\2050012\_03

ALL PROPRIETARY RIGHTS IN THE SUBJECT MATTER SHOWN ON THIS DRAWING ARE EXCLUSIVE PROPERTY OF HELLERMANNTYTON

**HellermannTyton**

7930 N. Faulkner Rd.  
 Milwaukee, WI 53224  
 Ph: (414) 355-1130  
 Fx: (414) 362-8338

**RT50S  
 RELEASABLE TIE**

Drawing-No **CT2050012CST**

Format AH  
 Sheet 1 of 1