

C3RWT & C3RWTG - SERIES

BUL86292

REV. B

ASSEMBLY INSTRUCTIONS FOR 3R TROUGH

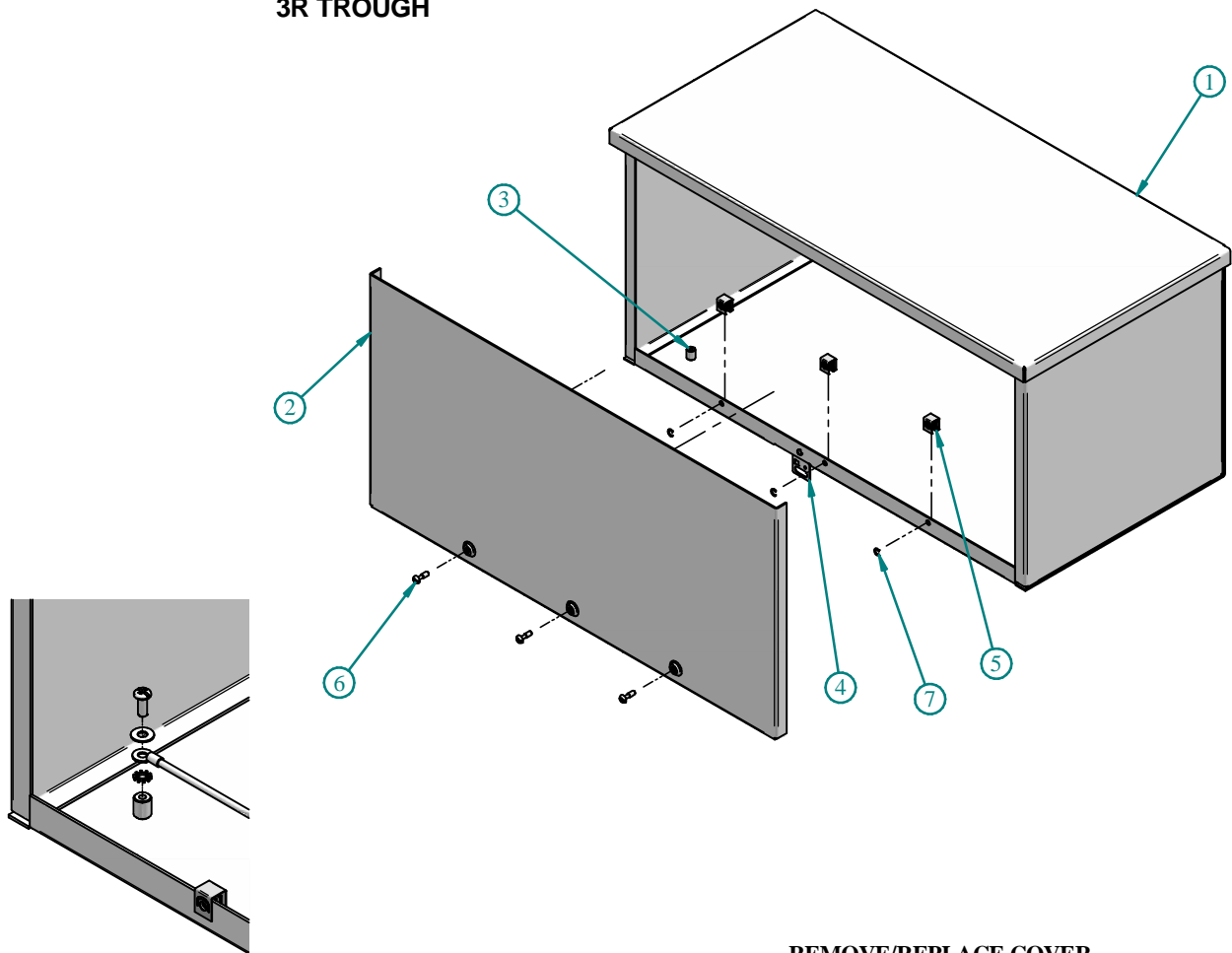

FIG. 1

ITEM No.	DESCRIPTION
1	C3RWT - BODY
2	C3RWT - COVER
3	STD - TAP 10-32
4	SPLITTER - HASP, DOOR
5	CLIP NUT ZP
6	SCREW PHIL/SLT TAPERED COMB.
7	RING RETAINING 1/4"--"C" SHAFT

TOOL BOX	Phillips Screw Driver	Slot Head Screw Driver

REMOVE/REPLACE COVER

- Remove screws in cover, screws are captivated, they do not come out all the way. Remove cover.
- Replace cover and tighten all screws.

MOUNTING ON WALL

- Mount on a wall using customer supplied hardware. Make sure trough is level and is mounted in the orientation shown above.

USING PADLOCK HASP

- To use hasp, rotate down to position shown. If using hasp remove ring retainers on screws for easier cover installation.
- If hasp is not required rotate up into enclosure.

GROUNDING

- Ground wire must be installed, refer to FIG. 1 for wire installation on the body and cover.

**HAMMOND
MANUFACTURING™**
www.hammondmfg.com