



FX-780 & FX-781 NITROGEN GENERATOR

The **HAKKO Nitrogen (N₂) Soldering System** is the ideal solution for all your lead-free hand-soldering applications. The bench-top FX-780 Nitrogen Generator creates nitrogen gas from filtered, dry compressed air and the FX-791 Nitrogen Controller delivers it efficiently and uniformly to the nitrogen compatible soldering iron and soldering area. It can be used with any HAKKO soldering station that has a nitrogen compatible handpiece.



FEATURES & BENEFITS

FX-780 & FX-781 NITROGEN GENERATOR

- High-volume, high-performance Nitrogen Generator
- Concentration of generated N₂ gas up to 99.9%
- Generator can be placed vertically or horizontally
- Nozzle assembly envelops the soldering iron tip and delivers uniform nitrogen gas to the soldering area
- The nitrogen flow can reduce or prevent oxidation from forming during the soldering process

FX-791 CONTROLLER

- Compact Nitrogen Controller
- Controls the flow of nitrogen to the FM-2026 nitrogen iron with the FX-951, FM-206 and FM-203 soldering stations
- Controls the flow level from 0.25 L/min to 2.5 L/min (recommended level 0.5-1.5 L/min.) and should be adjusted to the tip shape



SPECIFICATIONS

NITROGEN GENERATOR	FX780-01	FX781-81
Air Supply Pressure	0.3 - 0.7 MPa (44 - 102 psi)	
Concentration of Generated N₂	99.9% (max)	
Generated N₂ Gas Flow	1.5 L/min.	2.4 L/min.
Outer Dimensions (W x H x D) (w/o sockets and valve)	2.9 x 11.1 x 2.8 in. / 73 x 282 x 71 mm	2.9 x 16.02 x 2.8 in. / 73 x 407 x 71 mm
Weight	3.3 lb / 1.5 kg	4.4 lb / 2 kg
NITROGEN CONTROLLER	FX791-01	
Input Gas Pressure	0.2 - 0.9 MPa (28 - 129 psi)	
Output Gas Flow	0.25 - 2.5 L/min	
Input Hose	0.24 in. / 6.0 mm OD (not included)	
Outer Dimensions (W x H x D)	2.76 x 4.76 x 5.28 in. / 70 x 121 x 134 mm	
Weight	1.3 lb / 600 g	
Contents	FX-791 (1 pc)	

NITROGEN GENERATOR

FX-780*
SMALLER CAPACITY
NITROGEN GENERATOR
P/N: FX780-01

**Sold Separately*



FX-781
LARGER CAPACITY
NITROGEN GENERATOR
P/N: FX781-81



NITROGEN CONTROLLER

FX-791
NITROGEN CONTROLLER
P/N: FX791-01



Also Available:
FM2026-KIT
NITROGEN SOLDERING
SYSTEM KIT

Conversion Kit P/N: FM2026-KIT

This Conversion Kit is compatible with only the N₂ handpieces listed in the page 36



FOR ONE SOLDERING IRON

Small-capacity type : HAKKO FX-780
 Large-capacity type : HAKKO FX-781

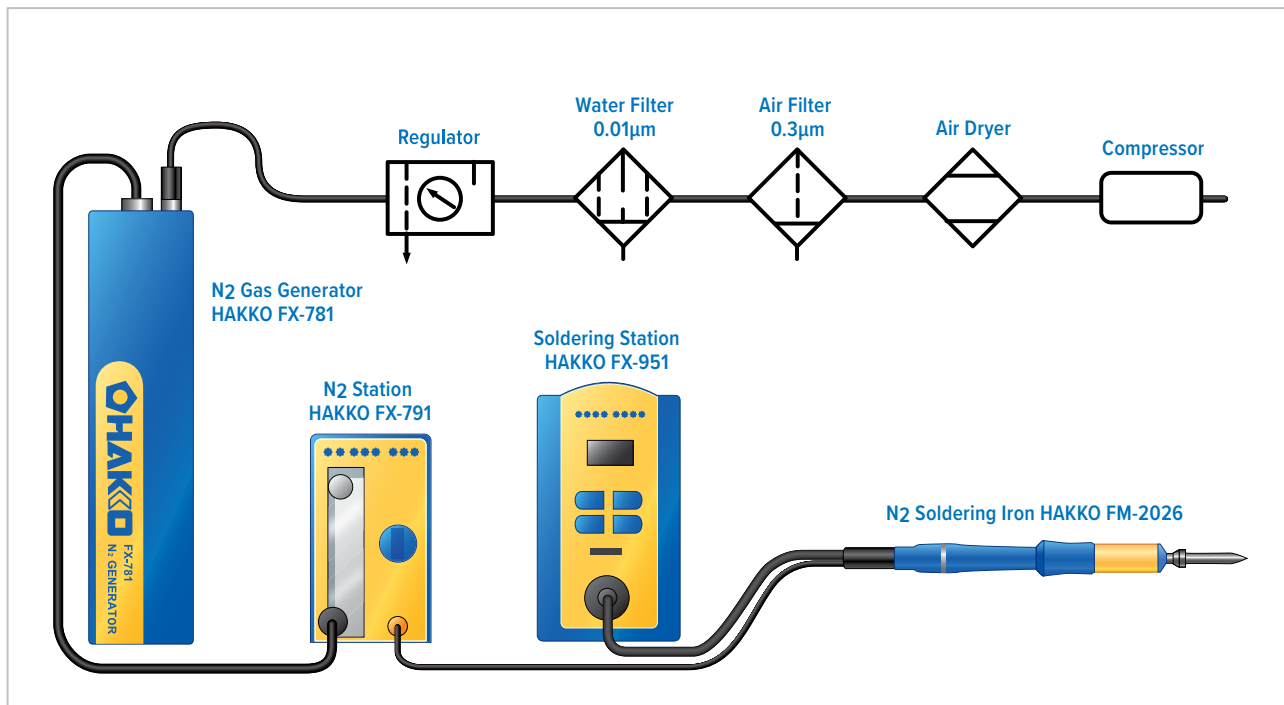

* It is capable to supply high concentration Nitrogen of 99.9% at the output rate approx. 1L/min.
 (at air supply pressure of 0.7MPa)

FOR TWO SOLDERING IRONS

Large-capacity type : HAKKO FX-781

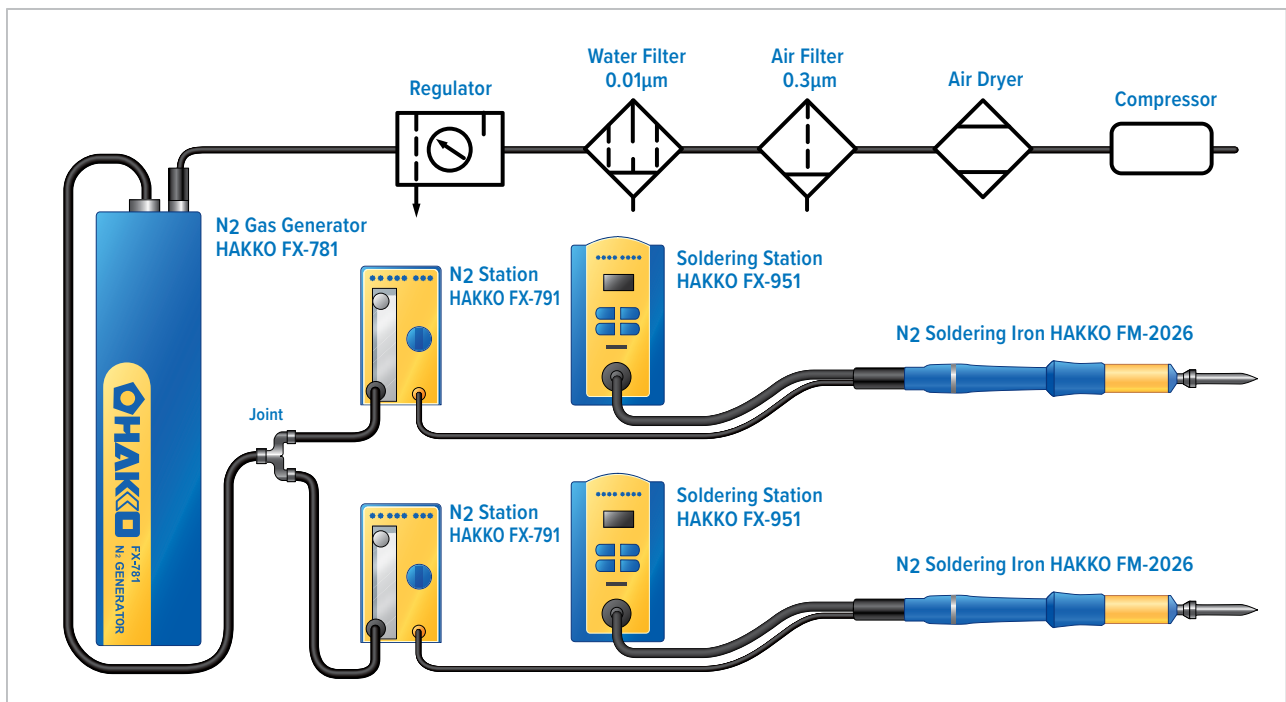









* It is capable to supply high concentration Nitrogen of 97% at the output rate approx. 1L/min.
 (at air supply pressure of 0.5MPa)

SOLDERING



NITROGEN HANDPIECE VARIATIONS

SOLDERING

Handpiece Only	Category	Station Compatibility	Power Consumption	Tips/Nozzles
 FX-9702 See page 37	Standard N ₂ Soldering Handpiece	Only for FX-971 & FX-972 stations	90 W / 24 VAC	T39 Series Not Included See page 24
 FM-2026 See page 38	Standard N ₂ Soldering Handpiece	Compatible w/ FX-971, FX-972, FX-951, FM-202, FM-203, FM-204, FM-205, FM-206 & FP-102, stations	70 W / 24 V	T17 Series Not Included See page 38
 FX-8802 See page 46	Standard Soldering w/ N ₂ capability	Compatible w/ FX-889, FX-888D, FX-888	65 W / 26 V	T18 Series Not Included See page 49
 FX-9704 See page 37	Micro N ₂ Soldering Handpiece	Only for FX-971 & FX-972 stations	70 W / 24 VAC	T50 Series Not Included See page 25
 FM-2032 See page 70	Micro Soldering w/ N ₂ capability	Compatible w/ FX-971, FX-972, FX-951, FM-203, & FM-206	48 W / 24 V	T30 Series , See page 70 N ₂ Nozzles (used with adaptor C5038 - C5040) assemblies See page 70
 FX-9708 See page 37	Heavy-Duty N ₂ Soldering Handpiece	Only for FX-972 station	200 W / 24 VAC	T53 Series , Not Included See page 28
 FM-2031 See page 39	Heavy-Duty N ₂ Soldering Handpiece	Compatible w/ FX-972 & FM-206 stations	140 W / 24 V	T22 Series , See page 39 N ₂ Nozzles (B3121, B3123, B3124 & B3561) assemblies
 FX-8005 See page 37	Ultra Heavy-Duty N ₂ Soldering Handpiece	Only for FX-805 station	390 W / 30 V	T33 Series , Not Included See page 33 N ₂ Nozzles (B5318, B5319 & B5320) assemblies See page 32 . T37 Series , Not Included See page 32 N ₂ Nozzles (B5316 & B5317) assemblies See page 32 .

These are the new nitrogen capable handpiece equivalents for the FX-9701, FX-9703, FX-9707 and for FX-8004 when equipped with the the FX-791 controller and FX-780 or FX-781 Nitrogen Generators



FX-9702

N₂ STANDARD SOLDERING HANDPIECE

P/N: FX9702-81

For more information
Scan QR Code.



FX-9704

N₂ MICRO SOLDERING HANDPIECE

P/N: FX9704-81

For more information
Scan QR Code.



FX-9708

N₂ HEAVY-DUTY SOLDERING HANDPIECE

P/N: FX9708-81

For more information
Scan QR Code.



FX-8005

N₂ ULTRA HEAVY-DUTY SOLDERING HANDPIECE

P/N: FX8005-81

For more information
Scan QR Code.





For more information
Scan QR Code.

FM-2026

NITROGEN SOLDERING IRON

The **HAKKO FM-2026 Soldering Iron** can be used with the HAKKO FM-203, FM-206 and FX-951 stations. Soldering efficiency is improved as the preheated nitrogen envelops the soldering iron tip.

T17 SERIES TIPS

SOLDERING



T17 SERIES TIPS FOR USE WITH FM-2026 NITROGEN SOLDERING IRON

UNIT: mm(inch)

Tip Part No.	Tip Shape	Nozzle Assy Part No.
T17-D08	(Chisel)	Nozzle Assy D
T17-D16	(Chisel)	Nozzle Assy C
T17-D24	(Chisel)	Nozzle Assy C
T17-B2	(Conical)	Nozzle Assy C
T17-J02	(Bent)	Nozzle Assy B
T17-BC1	(Bevel)	Nozzle Assy F
T17-BCF1	(Bevel)	Nozzle Assy F
T17-BC2	(Bevel)	Nozzle Assy A
T17-BCF2	(Bevel)	Nozzle Assy A
T17-BC3	(Bevel)	Nozzle Assy G
T17-BCF3	(Bevel)	Nozzle Assy G
T17-KF	(Knife)	Nozzle Assy J
T17-KU	(Knife)	Nozzle Assy H
T17-KR	(Knife)	Nozzle Assy I



NITROGEN CROSS REFERENCE FOR T17 TIPS AND N₂ NOZZLES

Compatible Tips	N ₂ Nozzle Assy Part No.	Description
T17-BC2, T17-BCF2	B2706	Nozzle Assembly A
T17-J02	B2707	Nozzle Assembly B
T17-D16, T17-B2, T17-D24	B2708	Nozzle Assembly C
T17-D08	B2709	Nozzle Assembly D
T17-BC1, T17-BCF1	B2899	Nozzle Assembly F
T17-BC3, T17-BCF3	B2900	Nozzle Assembly G
T17-KU	B2901	Nozzle Assembly H
T17-KF	B2923	Nozzle Assembly J
T17-KR	B2902	Nozzle Assembly I

NEW N₂ Handpiece
NITROGEN CONTROLLER
P/N: FM2026-06



For more T17 Series
information
Scan QR Code.



FM-2031

NITROGEN HEAVY DUTY SOLDERING IRON

The **HAKKO FM-2031 Nitrogen Heavy Duty Soldering Iron** is a compatible handpiece that can be attached to the FM-203 “D” port and the HAKKO FM-206 CH2 or CH3 ports.

T22 SERIES TIPS

For more information
Scan QR Code.



SOLDERING

T22 SERIES TIPS FOR USE WITH FM-2030 & FM-2031 HEAVY SOLDERING IRON

UNIT: mm(inch)

T22-BL	(Conical)	T22-BL2	(Conical)	T22-D16	(Chisel)	T22-D24	(Chisel)
	Nozzle Assy A N2 B3121		Nozzle Assy A N2 B3121		Nozzle Assy C N2 B3123		Nozzle Assy E N2 B3561
T22-C5	(Bevel)	T22-C6	(Bevel)	T22-D52	(Chisel)	T22-J02	(Bent Angle)
	Nozzle Assy D N2 B3124		Nozzle Assy D N2 B3124		Nozzle Assy D N2 B3124		Nozzle Assy A N2 B3121
T22-BC2	(Bevel)	T22-C3	(Bevel)	T22-D32	(Chisel)	T22-D45	(Chisel)
	Nozzle Assy A N2 B3121		Nozzle Assy A N2 B3121		Nozzle Assy D N2 B3124		Nozzle Assy D N2 B3124
T22-D08	(Chisel)	T22-D12	(Chisel)	T22-JD08	(Chisel)	T22-K	(Knife)
	Nozzle Assy C N2 B3123		Nozzle Assy A N2 B3121		Nozzle Assy E N2 B3561		Nozzle Assy C N2 B3123



For more T22 Series information
Scan QR Code.



NITROGEN CROSS REFERENCE For T22 TIPS AND N₂ NOZZLES

Compatible Tips	N ₂ Nozzle Assy Part No.	Description
T22-BL, T22-BL2, T22-BC2, T22-C3, T22-D12 & T22-J02	B3121	Nozzle Assembly A
T22-D08, T22-D16 & T22-K	B3123	Nozzle Assembly C
T22-C5, T22-C6, T22-D32, T22-D45, T22-D52	B3124	Nozzle Assembly D
T22-D24, T22-JD08	B3561	Nozzle Assembly E