

SmartLog Pro® 2 Stand Installation and Maintenance



Made in the
United States of America



Figure 1. EMIT 50417 SmartLog Pro® Stand

Description

The EMIT 50417 Stand is designed as a mounting alternative for the EMIT SmartLog Pro® 2. It is constructed of heavy gauge steel and powder-coated for minimized contamination when used in clean areas. The Stand allows administrators to setup the SmartLog Pro® 2 in a convenient area on the floor when wall-mounting is not available.

Packaging

- 1 Pedestal (Two-Pieces)
- 1 Base Plate
- 5 Socket Head Screw, 1/4-20 x 1/2"
- 2 Phillips Head Screw, 10-32 x 3/4"
- 2 Phillips Head Screw, 10-32 x 1/4"
- 2 Nut, 10-32
- 2 Nyloc Nut, 10-32
- 1 Cable Port Cover

Installation

1. Assemble the pedestal and base plate using the 5 socket head screws.

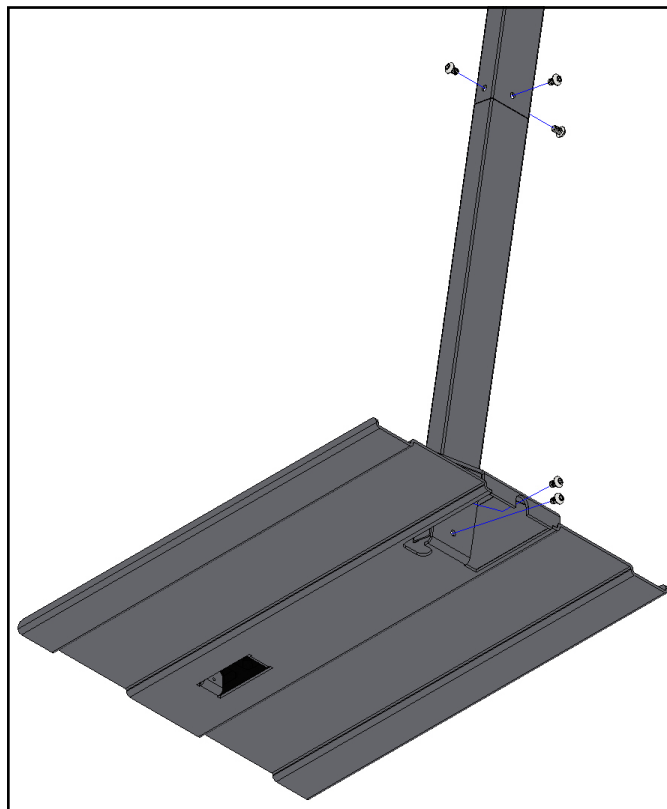

Figure 2. Assembling the pedestal and base plate using the 5 socket head screws

2. Align the tester mounting bracket's top and bottom holes to the two holes on the pedestal's mounting bracket. Align the cable port cover with the bottom holes on both the mounting bracket and pedestal. Secure the mounting bracket and cable port cover to the pedestal using the two Phillips head screws and nuts.

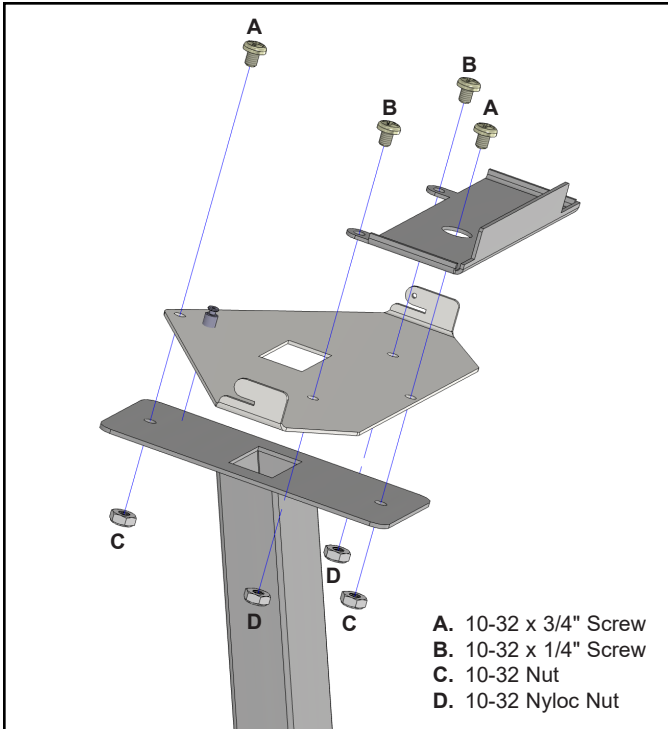

Figure 3. Securing the tester mounting bracket to the pedestal

3. Route the ground cord, foot plate cable, Ethernet cable, and power adapter through the pedestal. Feed the cords from the bottom and have them exit through the top.
4. Connect the ground cord, foot plate cable, power adapter, and Ethernet cable to the tester.
5. Connect the tester to the mounting bracket, and secure it using its included thumbscrew.

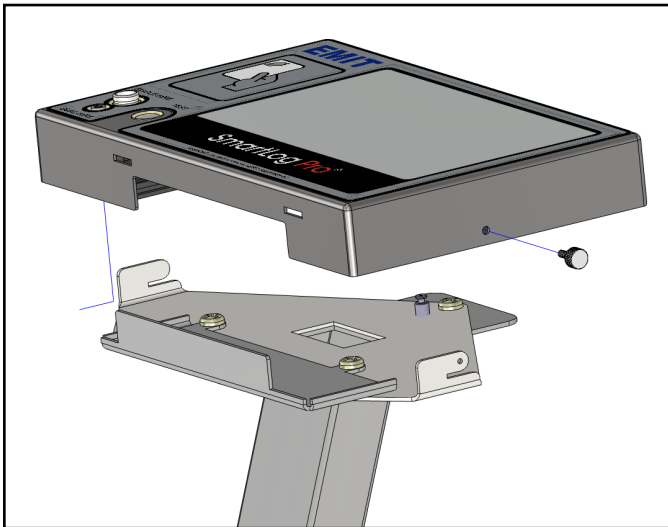

Figure 4. Securing the tester to its mounting bracket

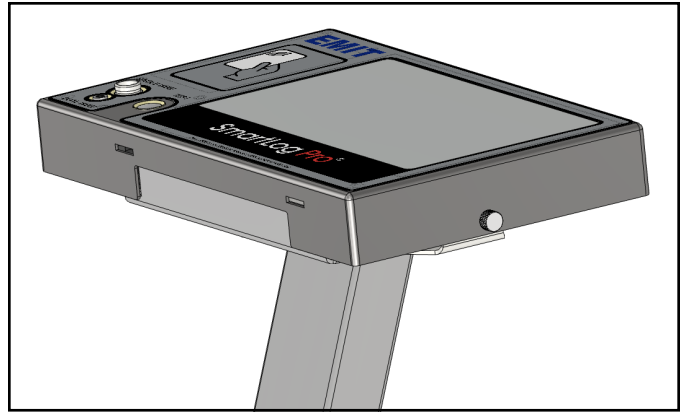

Figure 5. Final assembly of the tester on the pedestal

6. Connect the ground cord's ring terminal to a known ground point. Connect the foot plate cable to the foot plate. Verify that the Ethernet cable is connected to your network.
7. Lay the dual foot plate onto the base plate.

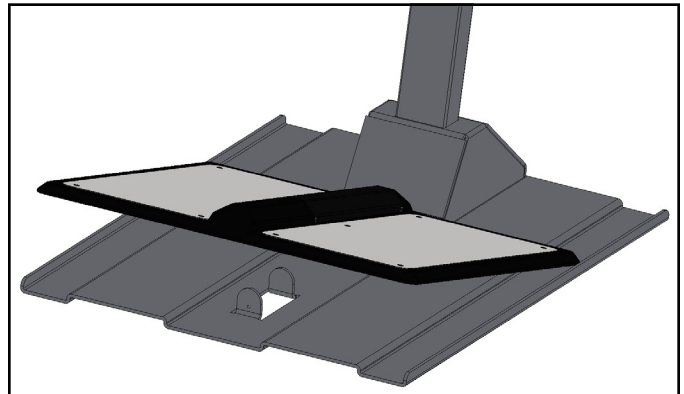

Figure 6. Installing the dual foot plate onto the baseplate

8. Connect the power adapter to an appropriate power outlet to power the tester. The display will turn on, and the boot sequence will initiate. The blue LEDs will continuously cycle around the test switch when the ESD tester is on standby.



Figure 7. Completed assembly of the SmartLog Pro® 2 and 50417 Stand



Figure 8. Using the 50417 Stand with the SmartLog Pro® 2

Maintenance

To maintain optimum performance, cleaning should be performed on a regular basis. Use a minimum of 80% Isopropyl alcohol to clean the foot plate and test switch of the SmartLog Pro® 2. Other cleaners are susceptible to leaving residue on these surfaces.

Specifications

Dimensions	19.0" x 15.5" x 38.0" (48 cm x 39 cm x 97 cm)
Weight	23 lbs (10.4 kg)
Construction	Grey powder-coated steel
Country of Origin	United States of America

Limited Warranty, Warranty Exclusions, Limit of Liability and RMA Request Instructions

See the EMIT Warranty - DescoEMIT.com/Warranty.aspx