

MEASUREMENT TIPS

Volume 4, Number 3

Achieve Cleaner Power Signals by Minimizing Common Sources of Noise



When noise is present in test or characterization systems, it often leads to the question of whether the DUT is producing a noisy output in response to a stable input signal or responding to noise at the input. You can spend a lot of time and energy troubleshooting the DUT, only to discover that the signal being input to the DUT is the source of the problem. It is possible to filter the noise at the DUT input, but it is often easier to reduce or eliminate the noise before it ever reaches the DUT. Understanding some common sources of noise will make it easier to minimize the noise in your test.

Snapshot: **Reducing noise in battery-powered device tests**

In the wireless communications market, battery operating times are improving and batteries are becoming smaller and more efficient. To support these trends, digital wireless products transmit in short bursts conserving power between transmissions. When using a power supply in place of the battery for testing, a high-volume manufacturer of wireless products found that the short transmission bursts caused pulses of current to be drawn from the power supply resulting in voltage transients at the wireless product's input and triggering the low-battery shutdown of the product. To avoid these disruptions in the test, the manufacturer minimized the impedance and noise in the lead wires by using low contact resistance relays and larger-gauge shielded twisted conductors.



Choosing a quality power supply

Using a low-noise power supply is the first step to keeping noise out of your test. Linear power supplies have a reputation for lower output noise and lower common mode current noise. Some switching power supplies, such as Agilent's N6700 modular power system or N6705A DC power analyzer, have been designed to minimize noise by employing extensive filtering techniques and reducing stray capacitive coupling. When you select a power supply that has been designed to reduce noise, it allows you to use a switching supply in applications where you previously may have thought only a linear design would have worked. A well designed switching power supply will have the low noise performance you would expect from a linear supply.

Whether you choose a power product with a linear supply or a switching supply, you are likely to have trouble if the common mode current is over 20 or 30 mA.

Normal mode voltage noise and common mode current noise

An ideal power supply has a perfect DC output with no AC signals across the output terminals or from the terminals to earth ground. In reality, power supplies have noise across the output terminals (normal mode voltage noise) and a flow of current through any impedance connected from either terminal to earth ground (common mode current noise). See Figure 1.

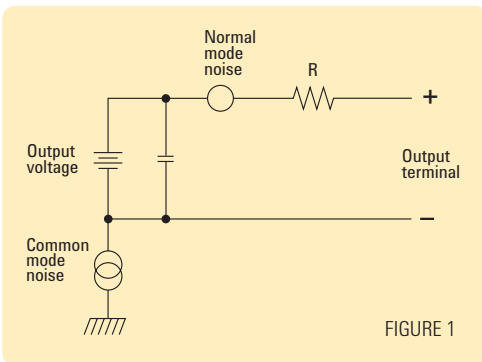

Normal mode voltage noise is in the form of ripple related to the line frequency in a linear design or the switching frequency in a switching design, plus some random noise. Normal mode voltage noise is typically very low in a quality power supply. You can maintain the low noise performance by minimizing noise pick-up. Do this by keeping the power supply circuitry away from devices that consume large amounts of power and other noise sources such as large motors or relays switching large currents.

MEASUREMENT TIP

Consumer and business appliances, such as copy machines, laser printers, computers, and telecom products, can contribute to power line noise. These products typically cycle through different modes of operation that draw non-linear current from the AC mains, resulting in current harmonics and voltage and current phase shifts causing noise on the AC mains supply. That noise can be conducted through the power cord of your power supply, so avoid plugging your power supply into the same AC mains circuit as these noise-generating appliances.

Common mode noise is generated when common mode current flows from inside the power supply through the output terminals to earth ground, generating a voltage drop across any impedance in the path. When multiple instruments are used, multiple paths to ground result. To minimize the conducted noise caused by ground loops, separate the DC distribution path from the other conductive paths that carry ground currents. You can also float the power supply by not referencing the power supply outputs to earth ground and eliminating the ground loop.

MEASUREMENT TIP

Another technique for minimizing the effect of common mode noise current is to equalize the impedance to ground from each of the power supply's output terminals as well as that of the inputs to the DUT. You can also use a common-mode choke in series with the output leads and a shunt capacitor from each lead to ground.

Changes in the Load

The DUT's current demand can change very rapidly causing the DC output voltage of the power supply to also change in response. To reduce any voltage spikes at the DUT, connect a low impedance bypass capacitor close to the DUT input.

The inductance of the lead wires can also cause a voltage spike to appear at the DUT in response to rapidly changing currents. You can reduce this spike by keeping the load wires as short as possible and by bundling the wires together as tightly as possible.

MEASUREMENT TIP

A direct connection to the DUT using shielded twisted pair is your best bet. Using shielded twisted conductors for both the output and remote sense leads will also minimize electric and magnetic pick-up noise. Ground the shield at only one end to make sure the shield doesn't conduct current.

Summary

Using clean power signals in your system improves the reliability of your test by reducing the chances that your DUT will fail due to a noisy signal at the input. We have reviewed ways to minimize or eliminate common sources of noise and reasons why using the right power supply, such as Agilent's N6700 family of modular systems and the N6705A DC power analyzer, is a great first step.

Helpful tools for power product users

Free DC Power Supply Hints and Tips

A series of useful tips to help you get the most out of your power supply

- *Create Complex Sequences with a DC Power Supply*
- *Improve Power Supply Performance and Safety Using Remote Sensing and Remote Inhibit*
- *Achieve Cleaner Power Signals by Minimizing Common Sources of Noise*



Agilent Power Products Selection Guide

Our new product guide helps you match Agilent power products to your test and measurement challenges

Since DC power supplies are used in such a wide variety of applications, Agilent offers more than 200 products designed to meet all your test requirements. Our new selection guide will help you evaluate and select the right Agilent product for your specific test need.



Yours FREE! Find these helpful tools and more at www.agilent.com/find/power_product_tips

www.agilent.com

For more information on Agilent Technologies' products, applications or services, please contact your local Agilent office. The complete list is available at:

www.agilent.com/find/contactus

Agilent DC Power Supplies



Over 200 models from 2 W to 6.6 kW



Agilent N6705A
DC power analyzer

Agilent N6700 low profile
modular power system



For more information on these and other Agilent power products please visit www.agilent.com/find/power

Product specifications and descriptions in this document subject to change without notice.

© Agilent Technologies, Inc. 2008
Printed in USA, August 20, 2008
5989-8852EN



Agilent Technologies