



110 Fairgrounds Drive • P.O. Box 188 • Manlius, NY 13104-0188 USA • 315.682.9176 • FAX: 315.682.9160

OPERATOR'S MANUAL



Model 27G Rotary Collet Magnet Wire Stripper

PRODUCTION WIRE PROCESSING EQUIPMENT

Website: www.carpentermfg.com • e-mail: wire@carpentermfg.com

CARPENTER MODEL 27G MAGNET WIRE STRIPPER

INTRODUCTION

Thank you for choosing Carpenter Mfg. Co. Inc. Wire Processing Equipment. For over 50 years Carpenter has been a leader in Wire Processing Technology and Service. Our desire has always been to bring you reliable products. We look forward to a long healthy relationship with you and our company.

The MODEL 27G can process a wide range of wire as referenced on the following page. These processing specifications are based upon the most commonly manufactured wire. Special applications may arise with wires that are within the specification limits of the machine but are very difficult or unsuccessful to process. Likewise, wires that exceed the specified limits of the machine can sometimes be processed. Because there are many variables involved in Wire Processing we strongly recommend a free Wire Evaluation at our factory followed by a demonstration from a Carpenter representative to insure the ultimate success of your Wire Processing Application.

This operating manual explains how to operate the MODEL 27G. To ensure the best performance of your machine, read this manual carefully until you familiarize yourself thoroughly with its operation and features. After you have read through the manual, keep it available for reference. If you have any questions about this machine or service please let us know. Our phone number is 315.682.9176, fax number 315.682.9160. Website: www.carpentermfg.com, E-mail: wire@carpentermfg.com.

CARPENTER MODEL 27G MAGNET WIRE STRIPPER

IMPORTANT NOTICE

The products in this shipment left our facility in good working condition.

Their safe delivery is the responsibility of the carrier that delivered this shipment to you.

Our stated shipping terms are F.O.B. our facility at 110 Fairgrounds Drive, Manlius, NY 13104.

According to applicable laws, the responsibility for this shipment was transferred to you as soon as the carrier accepted the goods at our warehouse.

If concealed damage is discovered after unpacking this shipment, you must submit a damaged freight claim with the carrier.

Carpenter Mfg. Co., Inc. cannot submit your claim for you.

In order for you to collect for concealed damage, the carrier must be notified with 5 days of the date you receive this shipment.

You must leave the damaged items and packing material as is (i.e. return all merchandise and all packing material to the shipping container) until the claim has been inspected by the carrier.

Also, the carrier will not accept a claim if the goods have been moved from the point of the carriers delivery to another street address.

If you have any questions or problems, please give us a call at 315.682.9176.

CARPENTER MODEL 27G MAGNET WIRE STRIPPER

APPLICATION

The Model 27G is designed for end stripping heavy and medium gauge round film insulated solid wire, ranging from 6 to 25 AWG (4.11 to .45mm) using slotted stripping inserts.

Stripping inserts are available in Standard Steel, Bullet Nosed Steel or Carbide in the following sizes:

<u>PART NO.</u>	<u>RANGE</u>
728	20 AWG (.81mm & smaller)
732	15-20 AWG (1.45 to .81mm)
736	12-15 AWG (2.05 to 1.45mm)
740**	8-12 AWG (3.26 to 2.05mm)
744*	6-8 AWG (4.11 to 3.26mm)

* - Only available in Standard Steel

** - Only available in Standard Steel & Carbide

MACHINE SET UP

Install proper size Stripping Insert by loosening the collet nut and placing the insert into the collet body. Replace collet nut but do not tighten, the Stripping Insert should project approximately 3/16". Place the wire to be stripped into the insert and tighten collet nut until finger tight. Make an initial test strip and re-adjust collet nut with supplied wrenches as required for desired strip.

Strip length is controlled by loosening the set screw located in the motor shaft. This allows positioning of the Stop Rod within the hollow motor shaft. After the desired strip length is obtained retighten the set screw. Removal of Stop Rod permits strip lengths up to approximately 3" on certain wires.

MACHINE OPERATION

Feed your wire into the rotating Stripping Insert until Stop Rod is contacted and then withdraw. The slotted insert quickly removes the film insulation close to the body of a component.

A #1939D Flexible Shaft Assembly, may be installed on the Model 27G to allow increased portability for stripping medium gauge wire in the 15 to 25 AWG range.

CARPENTER MODEL 27G MAGNET WIRE STRIPPER

WARRANTY

Carpenter Mfg. Co., Inc. manufactures its products to be free from defects in materials and workmanship. Should any defect occur within 1 year after shipment, Carpenter Mfg. Co., Inc. will at its option, exchange or repair the defective device.

Repairs or adjustments to equipment under warranty can be performed at our factory or at the customer location, at the option of Carpenter Mfg. Co., Inc. In most cases a 1-2 day turn around time will be necessary to repair equipment at our facility. When equipment is returned to our factory for repair or replacement, freight charges will be borne by the customer. Repaired or replaced equipment will be returned at Carpenter's expense via U.P.S. ground service. If alternate shipping is requested by the customer, the difference in shipping charges will be billed to the customer.

This is a limited warranty and is in lieu of all other representations and expressed and implied warranties (including the implied warranties of merchantability and fitness for use.) Under no circumstances shall Carpenter Mfg. Co., Inc. be liable for any incidental or consequential property damages or losses subsequent to misuse or improper maintenance of this equipment.

Not covered by this warranty are:

- Consumable parts (blades, belts, guides, springs, inserts, stripping wheels, etc.)
- Cosmetic problems (nicks, scratches, etc.)
- Damages caused by any repairs or modifications by unauthorized personnel
- Abuse
- Damage caused by shipping
- Damage caused by environmental and/or atmospheric conditions

INSTALLATION OF THE 1939D TO A M27G

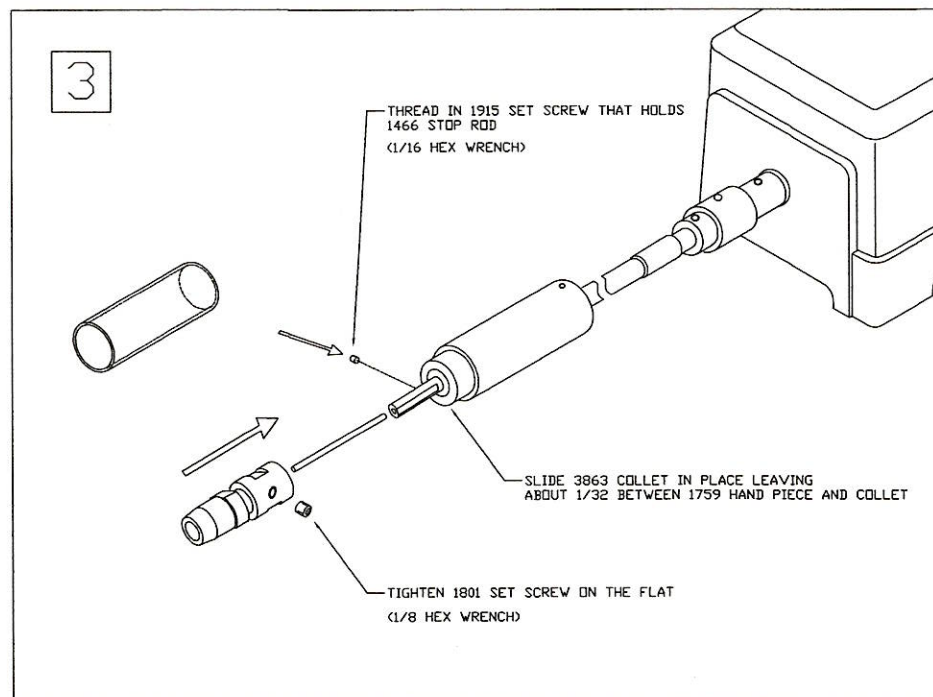
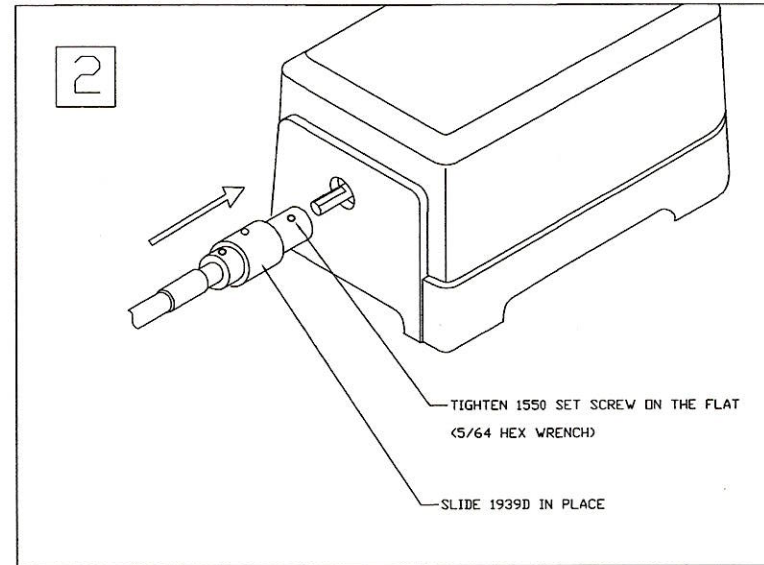
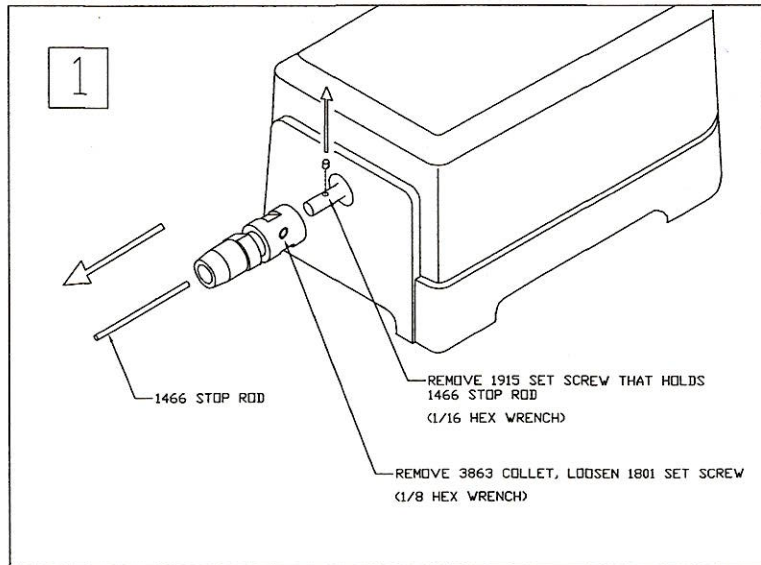

4318 DIGITALLY CONTROLLED
SOFT START MOTOR.
(115-230VOLT)

8340 MOTOR MOUNT

8756 NAMEPLATE

4306 BASE

1801 SCREW

3863 COLLET

1466 STOP ROD

1829 WRENCH

1658 WRENCH

1516 X2 WRENCH

LIGHT GAGE
BLACK WIRE

CW LE W/JUMPER

BLACK WIRE
WHITE STRIPE

WIRE NUT

GREEN WIRE, GROUND TO MACHINE

WHITE WIRE

LINE CORD IN

BLACK WIRE

BLACK WIRE

WIRE NUTS

BLACK WIRE

POWER SWITCH

BLACK WIRE

1509 X3 WIRE NUT

1515 POWER SWITCH

1861 LINE CORD

1518 STRAIN RELIEF

3628 X2 SCREW

4311 ELECTRICAL COVER

GROUND FROM LINE CORD

3849 STAR WASHER

5417 X4 SCREW

M27G
6/9/17

